



SIZES FROM 350 – 20,000 Nm

TORSIONALLY STIFF DISC PACK COUPLINGS

GENERAL INFORMATION ABOUT R+W DISC PACK COUPLINGS:



SERVICE LIFE

R+W disc pack couplings are fatigue resistant and wear free for an infinite service life, as long as the technical limits are not exceeded.

FIT CLEARANCE

Overall shaft / hub clearance of 0.01 - 0.05 mm

TEMPERATURE RANGE

-30 to +280° C

ROTATIONAL SPEED

see table

DELIVERY

LP couplings are delivered with the disc packs pre-assembled. They need only to be mounted to the hubs.

ATEX (Optional)

For use in hazardous areas available upon request.

TORSIONALLY STIFF DISC PACK COUPLINGS SIZES FROM 350 – 20,000 Nm

MODEL

FEATURES

LP1



**with keyway mounting
from 350 - 20,000 Nm**

- ▶ very high torsional stiffness
- ▶ single flex design
- ▶ compact layout
- ▶ compensates for axial and angular misalignment

Page 72

LP2



**with keyway mounting
from 350 - 20,000 Nm**

- ▶ high torsional stiffness
- ▶ double flex design
- ▶ customer specified length available
- ▶ compensates for axial, angular, and lateral misalignment

Page 73

LP3



**with conical clamping ring
from 350 - 20,000 Nm**

- ▶ high torsional stiffness
- ▶ high clamping pressure
- ▶ backlash free torque transmission
- ▶ good for high speed, reversing and intermittent loading

Page 74

LPA



**with keyway mounting for API 610
pump systems
from 350 - 20,000 Nm**

- ▶ customizable for individual project requirements
- ▶ intermediate tube removable without disturbing adjacent equipment
- ▶ integral safety catch in case of disc pack rupture
- ▶ customer specified DBSE available

Page 75

DESIGN

DISC PACK COUPLINGS

R+W disc pack couplings transmit torque across the disc pack assemblies purely by friction, thus avoiding stress concentration, backlash, and micro-movements resulting from transmitting torque across shoulder bolts. This aids in approaching infinite life in addition to making the complete coupling assembly more torsionally stiff.

R+W disc pack couplings are shipped as individual components. Assembly is required.



MISALIGNMENT COMPENSATION

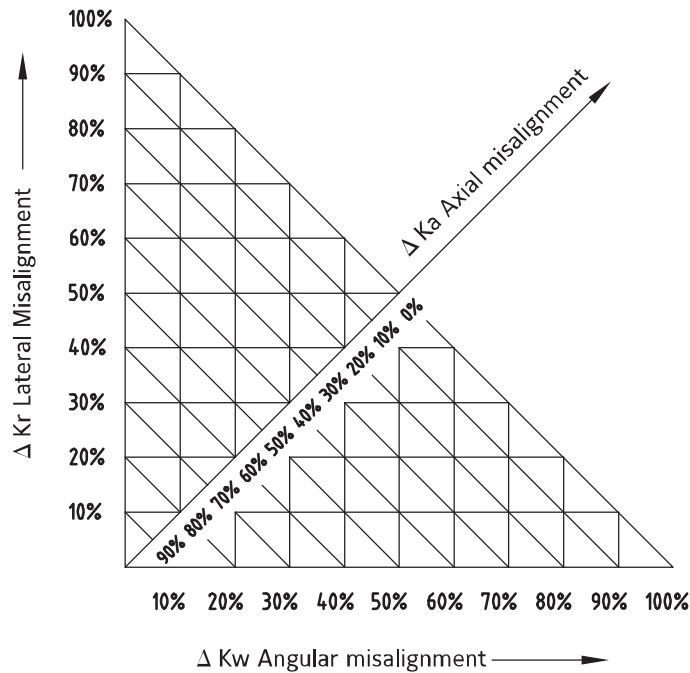

$$\Delta K_{total} = \Delta K_r + \Delta K_w + \Delta K_a \leq 100\%$$

These couplings compensate for varying combinations of shaft misalignment types as percentages of the total allowable misalignment values listed in the data tables. The total sum of the three misalignment percentages must not exceed 100%.

Example: pump skid

axial misalignment: 20%
 lateral misalignment: 40%
 angular misalignment: 40%

$$\Delta K_{total} = 20\% + 40\% + 40\% \leq 100\%$$

➔ coupling is fatigue resistant

LP1

WITH KEYWAY MOUNTING

350 - 20,000 Nm



ABOUT

FEATURES

- ▶ very high torsional stiffness
- ▶ single flex design
- ▶ wear and maintenance free

MATERIAL

- ▶ **Disc pack:** highly elastic spring steel
- ▶ **Hubs:** high strength steel

DESIGN

Two precision machined coupling hubs mounted to the disc pack by means of high strength screws and bushings for alignment and frictional clamping of the assembly. Axial retention with DIN 916 set screws.

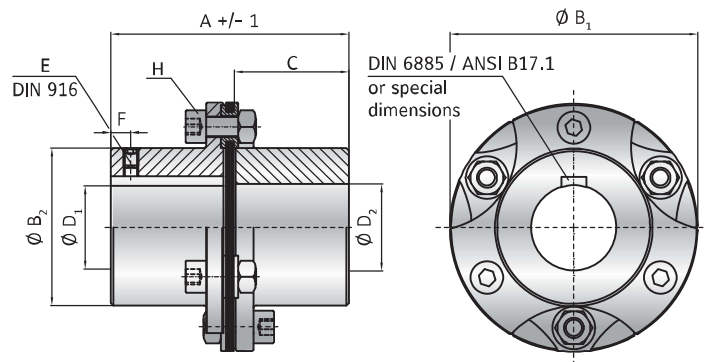

MODEL LP1

SIZE			300	700	2000	4000	7000	10000
Rated torque (Nm)	T_{KN}		350	700	2000	4500	7600	10000
Maximum torque (Nm)	T_{Kmax}		700	1400	4000	9000	15200	20000
Overall length (mm)	A		95	116	158	193	216	268
Outside diameter (mm)	B_1		99	128	150	198	238	298
Hub diameter (mm)	B_2		63	78	86	120	140	194
Hub fit length (mm)	C		45	55	75	90	100	125
Bore diameter available from \emptyset to \emptyset H7 (mm)	$D_{1/2}$		18 - 48	25 - 58	28 - 64	38 - 90	50 - 102	70 - 140
Set screw (DIN 916)	E		see table (depends on bore diameter)*					
Distance to screw (mm)	F		15	15	20	20	25	30
Assembly screw (ISO 4762) Nut (DIN 934)	H		M8	M10	M16	M20	M24	M24
Tightening torque (Nm)			38	75	320	650	1000	1100
Moment of inertia ($10^{-3}kgm^2$)	$J_{ges.}$		1.8	5.6	13.9	52.2	127	412
Material			steel	steel	steel	steel	steel	steel
Approximate weight (kg)			2	3.8	6.7	13.3	20.9	41.4
Torsional stiffness ($10^3Nm/rad$)	C_T		470	1200	1500	3600	6000	13300
Axial \pm (mm)			0.5	0.75	1	1.25	1.25	1.5
Angular \pm (degree)			0.7°	0.7°	0.7°	0.7°	0.7°	0.7°
Maximum speed (1/min.)			10000	8000	6000	5000	4500	4000
Bore range \emptyset (mm)			\emptyset 18 - 30	\emptyset 30.1 - 44	\emptyset 44.1 - 65	\emptyset 65.1 - 85	\emptyset 85.1 - 110	\emptyset 110.1 - 140
Set screw size*			M5	M8	M10	M12	M16	M20

ORDERING EXAMPLE	LP1	700	42	38.1	XX
Model	●				Special designation only (e.g. special bore tolerance).
Size		●			
Bore D1 H7			●		
Bore D2 H7				●	
For custom features place an XX at the end of the part number and describe the special requirements (e.g. LP1 / 700 / 42 / 38.1 / XX; XX = stainless steel)					

LP2

WITH KEYWAY MOUNTING

350 - 20,000 Nm

ABOUT



FEATURES

- ▶ high torsional stiffness
- ▶ double flex design
- ▶ customer specified length available

MATERIAL

- ▶ **Disc packs:** highly elastic spring steel
- ▶ **Hubs and spacer:** high strength steel

DESIGN

Two precision machined coupling hubs and precision spacer tube mounted to the disc packs by means of high strength screws and bushings for alignment and frictional clamping of the assembly. Axial retention with DIN 916 set screws.

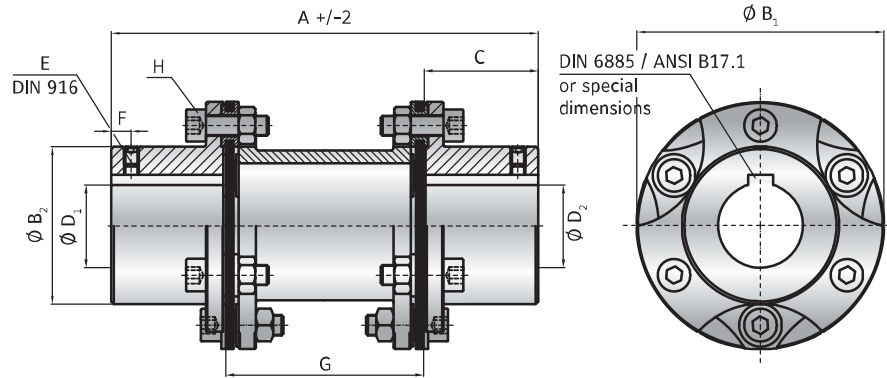

MODEL LP2

SIZE	300		700		2000		4000		7000		10000	
Rated torque (Nm) T_{KN}	350		700		2000		4500		7600		10000	
Maximum torque (Nm) T_{Kmax}	700		1400		4000		9000		15200		20000	
Overall length (mm) A	170	186	206	226	286	292	320	340	370	394	470	482
Outside diameter (mm) B_1	99		128		150		198		238		298	
Hub diameter (mm) B_2	63		78		86		120		140		194	
Hub fit length (mm) C	45		55		75		90		100		125	
Bore diameter available from ϕ to ϕ H7 (mm) $D_{1/2}$	18 - 48		25 - 58		28 - 64		38 - 90		50 - 102		70 - 140	
Set screw (DIN 916) E	see table (depends on bore diameter)*											
Distance to screw (mm) F	15		15		20		20		25		30	
Distance (mm) G	80	96	96	116	136	142	140	160	170	194	220	232
Assembly screw (ISO 4762) Nut (DIN 934) H	M8		M10		M16		M20		M24		M24	
Tightening torque (Nm)	38		75		320		650		1000		1100	
Moment of inertia (10^{-3}kgm^2) $J_{ges.}$	3	3.1	7.4	7.7	25	25.2	89.3	90.4	230	236	721	726
Material	steel		steel		steel		steel		steel		steel	
Approximate weight (kg)	3		4.7		11		20.7		35		68.8	
Torsional stiffness (10^3Nm/rad) C_T	220		550		700		1700		2800		6200	
Axial \pm (mm)	1		1.5		2		2.5		2.5		3	
Lateral \pm (mm)	0.8	1	1	1.3	1.4	1.5	1.4	1.6	1.6	1.9	2.2	2.4
Angular \pm (degree)	1°		1°		1°		1°		1°		1°	
Maximum speed (1/min.)	10000		8000		6000		5000		4500		4000	
Bore range ϕ (mm)	ϕ 18 - 30		ϕ 30.1 - 44		ϕ 44.1 - 65		ϕ 65.1 - 85		ϕ 85.1 - 110		ϕ 110.1 - 140	
Set screw size*	M5		M8		M10		M12		M16		M20	

ORDERING EXAMPLE	LP2	700	206	38.1	42	XX
Model	●					Special designation only (e.g. special bore tolerance).
Size		●				
Overall length mm			●			
Bore D1 H7				●		
Bore D2 H7					●	
For custom features place an XX at the end of the part number and describe the special requirements (e.g. LP2 / 700 / 206 / 38.1 / 42 / XX; XX = stainless steel)						

DISC PACK COUPLINGS LP

LP3

WITH CONICAL CLAMPING RING

350 - 20,000 Nm



ABOUT

FEATURES

- ▶ high torsional stiffness
- ▶ high clamping pressure
- ▶ backlash free torque transmission
- ▶ good for high speed, reversing and intermittent loading

DESIGN

Two precision machined conical clamping ring hubs and precision spacer tube mounted to the disc packs by means of high strength screws and bushings for alignment and frictional clamping of the assembly.

MATERIAL

- ▶ **Disc packs:** highly elastic spring steel
- ▶ **Hubs and spacer:** high strength steel

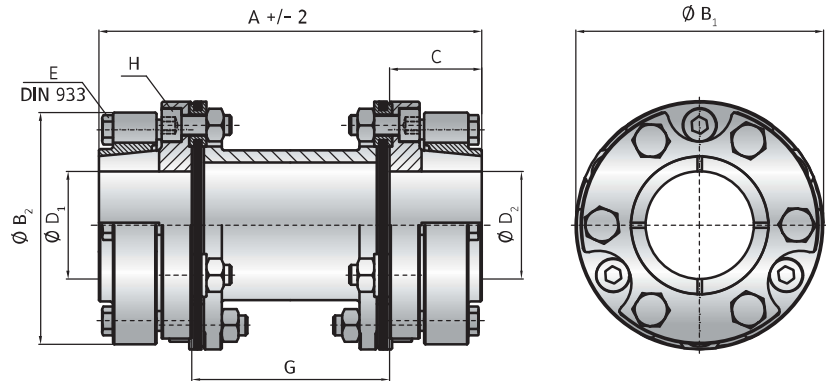

MODEL LP3

SERIE			300	700	2000	4000	7000	10000
Rated torque (Nm)	T_{KN}		350	700	2000	4500	7600	10000
Maximum torque (Nm)	T_{Kmax}		700	1400	4000	9000	15200	20000
Overall length (mm)	A		153	198	303	321	410	490
Outside diameter (mm)	B_1		99	128	150	198	238	298
Hub diameter (mm)	B_2		95	125	146	194	234	294
Hub fit length (mm)	C		37	51	71	92	120	135
Bore diameter* available from \varnothing to \varnothing H7 (mm)	$D_{1/2}$		24 - 50	30 - 65	35 - 70	50 - 100	60 - 115	70 - 170
Clamping screws (ISO 4017)	E		6x M8	6x M10	6x M12	6x M16	6x M20	6x M20
Tightening torque (Nm)			25	50	100	250	470	500
Distance (mm)	G		79	96	161	137	170	220
Assembly screw (ISO 4762) Nut (DIN 934)	H		M8	M10	M16	M20	M24	M24
Tightening torque (Nm)			38	75	320	650	1000	1100
Moment of inertia (10^{-3}kgm^2)	$J_{ges.}$		4.2	16.2	44.5	167	468	1280
Material			steel	steel	steel	steel	steel	steel
Approximate weight (kg)			3.2	7.3	14.8	31.4	59.3	98.4
Torsional stiffness (10^3Nm/rad)	C_T		220	550	700	1700	2800	6200
Axial \pm (mm)			1	1.5	2	2.5	2.5	3
Lateral \pm (mm)			0.8	1	1.5	1.4	1.6	2.2
Angular \pm (degree)			1°	1°	1°	1°	1°	1°
Maximum speed (1/min.)			10000	8000	6000	5000	4500	4000

* transmittable torque can depend on the bore diameter (contact supplier for details)

ORDERING EXAMPLE	LP3	700	198	42	38.1	XX
Model	●					Special designation only (e.g. special bore tolerance).
Size		●				
Overall length			●			
Bore D1 H7				●		
Bore D2 H7					●	
For custom features place an XX at the end of the part number and describe the special requirements (e.g. LP3 / 700 / 198 / 42 / 38.1 / XX; XX = stainless steel)						



FOR API 610 REQUIREMENTS

350 - 20,000 Nm

ABOUT



FEATURES

- ▶ meets all requirements of API 610
- ▶ intermediate tube removable without disturbing adjacent equipment
- ▶ integral safety catch in case of disc pack rupture
- ▶ ISO G6.3 / AGMA class 9 minimum balance quality
- ▶ highly customizable

▶ **Hubs and spacer:** high strength steel

DESIGN

Two precision machined coupling hubs and precision spacer tube mounted to the disc packs by means of high strength screws and bushings for alignment and frictional clamping of the assembly. Axial retention with DIN 916 set screws.

MATERIAL

- ▶ **Disc packs:** highly elastic, corrosion resistant spring steel

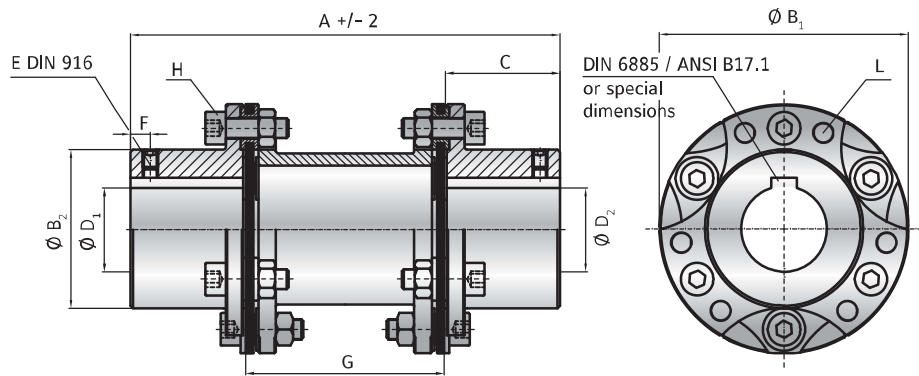

MODEL LPA

SIZE	300		700		2000		4000		7000		10000	
Rated torque (Nm) T_{KN}	350		700		2000		4500		7600		10000	
Maximum torque (Nm) T_{Kmax}	700		1400		4000		9000		15200		20000	
Overall length (mm) A	190	230	250	290	330	400	360	430	380	450	500	550
Outside diameter (mm) B_1	104		130		160		202		248		312	
Hub diameter (mm) B_2	63		78		86		120		140		194	
Hub fit length (mm) C	45		55		75		90		100		125	
Bore diameter available from \emptyset to \emptyset H7 (mm) $D_{1/2}$	18 - 48		25 - 58		28 - 64		38 - 90		50 - 102		70 - 140	
Set screw (DIN 916) E	see table (depends on bore diameter)*											
Distance to screw (mm) F	15		15		20		20		25		30	
Distance (mm) G	100	140	140	180	180	250	180	250	180	250	250	300
Assembly screw (ISO 4762) Nut (DIN 934) H	M8		M10		M16		M20		M24		M24	
Tightening torque (Nm)	38		75		320		650		1000		1100	
Safety catch screws (DIN 916) L	M6		M8		M10		M12		M16		M20	
Moment of inertia (10^{-2} Nm/kgm ²)	3	3.1	7.4	7.7	25	25.2	89.3	90.4	230	236	721	726
Material	steel		steel		steel		steel		steel		steel	
Approximate weight (kg)	3		4.7		11		20.7		35		68.8	
Torsional stiffness (10^3 Nm/rad) C_T	220		550		700		1700		2800		6200	
Axial \pm (mm)	1		1.5		2		2.5		2.5		3	
Lateral \pm (mm)	0.8	1	1	1.3	1.4	1.5	1.4	1.6	1.6	1.9	2.2	2.4
Angular \pm (degree)	1°		1°		1°		1°		1°		1°	
Maximum speed (1/min.)	10000		8000		6000		5000		4500		4000	

Bore range \emptyset	\emptyset 18 - 30	\emptyset 30.1 - 44	\emptyset 44.1 - 65	\emptyset 65.1 - 85	\emptyset 85.1 - 110	\emptyset 110.1 - 140
Set screw size*	M5	M8	M10	M12	M16	M20

ORDERING EXAMPLE	LPA	700	250	42	38.1	XX
Model	●					
Size		●				
Overall length mm			●			
Bore D1 H7				●		
Bore D2 H7					●	
For custom features place an XX at the end of the part number and describe the special requirements (e.g. LPA / 700 / 250 / 42 / 38.1 / XX; XX = stainless steel)						

DISC PACK COUPLINGS LP