

## Solutions for Drive Technology

- Incremental Encoders
- Absolute Encoders
- Safety Technology
- Fixing and Connection Solutions
- Customer-specific Development



## Reliable and economical total encoder solutions for drive technology.

Kübler has been highly successful in drive engineering for many years and counts internationally important businesses amongst its clientele. Along with excellent product quality, this sector demands a high degree of flexibility, a rapid response and service on a global scale. Kübler fully lives up to these expectations.

**Product diversity & Quality:** we guarantee our absolute and incremental encoders with their high shaft load capacity by the use of, for example, the sturdy bearing construction with Safety-Lock™, the 100 % magnetic field resistant optical technologies and by a remarkably compact product design.

**The mechanical interface is often the deciding path to success:** Kübler possesses the expertise and experience when it comes to essential details such as torque arms and mounting solutions for optimal integration of the encoders into the drives. We have been particularly successful with geared motors in developing a method of mounting the encoder under the fan cowl, which is both safe and cost-effective.

**At the forefront of technology:** Our innovations include encoders for Functional Safety with SIL3 approval, EX protection, encoders with total magnetic insensitivity, as well as purely optical encoders with a mechanical gear or with an electronic gear.

**Kübler Design System:** Kübler "KDS" is our structured method for converting – step-by-step – your requirements, with respect to quality and to a reduction in costs and number of models, into a product solution. Our goal is to provide tailor-made systems, customised to your requirements.

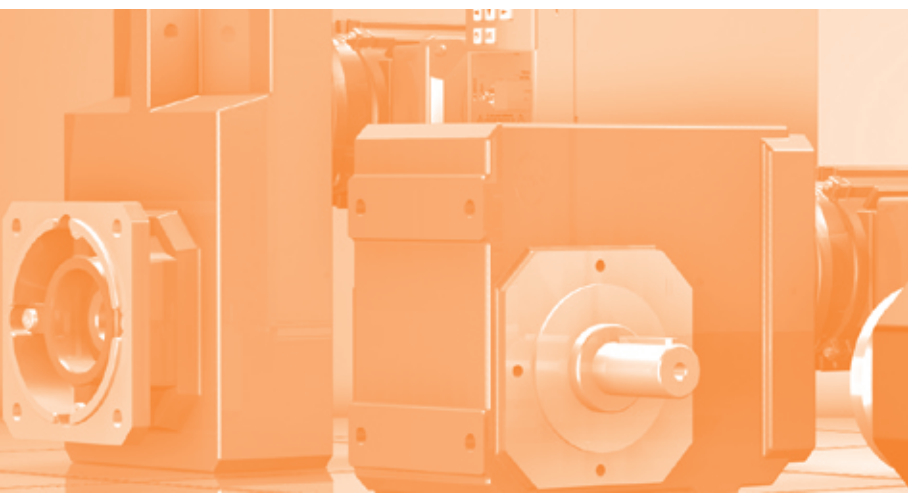



Kübler Headquarters, Villingen-Schwenningen, Germany



### Technologies for Drive Engineering

P. 4



### Encoders for Drive Technology

Asynchronous motors	P. 6
Large motors / Generators	P. 10
Synchronous motors	P. 12
Explosion protection – ATEX	P. 16
Functional Safety Technology - SIL	P. 17



### Interfaces and Accessories

Encoder interfaces	P. 18
Fixing and connection solutions	P. 20

### Customer-specific Development

Optimal sensor solution thanks to customer-specific development	P. 22
---	-------

The Kübler Group belongs today to the leading specialists worldwide in the fields of position and motion sensors, counting and process technology as well as transmission technology. Founded in the year 1960 by Fritz Kübler, the family business is now led by the next generation of the family, his sons Gebhard and Lothar Kübler. Proof of the strong international focus lies in the fact that exports currently account for over 60 percent of turnover, with 8 international group members and distributors in more than 50 countries. Over 380 dedicated people worldwide, of whom 290 are in Germany, make this success possible. They ensure that customers can place their trust in our company. The Kübler Group has a clear, long-term strategy to continue as an independent, owner-managed family business.

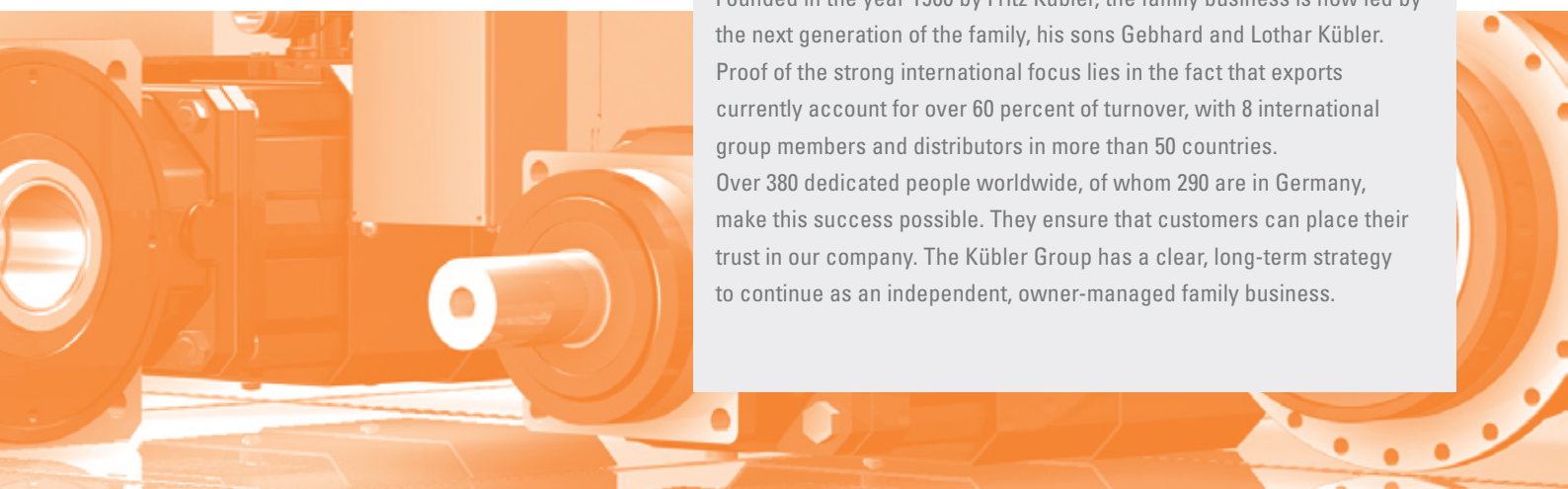

# Technologies for drive engineering

Innovations from tradition. Kübler products benefit from 50 years experience in automation technology. Over time they have been further developed for use in drive engineering. Small details make a big difference. Our products feature many intelligent top-quality extras and offer our customers key benefits. In doing so, they make a significant contribution to the high availability and safety of the machines.

## Optical encoder technology



100 percent resistant to magnetic fields – extremely compact design. Even strong magnetic fields, as occur in the vicinity of brakes or drive motors, pose no problems for the sensor technology of optical encoders. The technology dispenses with any components that may be susceptible to magnetic influences and allows for high scanning rates. The multiturn gear module – developed from special materials – is effective thanks to its double bearing layer and the specially developed gear teeth, resistant against wear, and can be used for high speeds up to 9000 rpm. As a result of the proven drive, the encoder has no need of a battery to store the number of revolutions.

## Insensitive to interference: OptoASICs



The resistant Kübler OptoASIC technology offers a very high integration density of components. This means that, on the one hand, the reliability in the application can be increased significantly, and on the other hand the technology demonstrates quality EMC characteristics and shock resistance.

## Wide temperature range



High heat resistance – combined with high rotational speeds – make the Kübler Sendix encoders the optimal solution for all applications in a high temperature environment. Also the seals, cables and connectors used withstand extreme temperatures.

## Electrical interfaces



Kübler encoders boast a wide variety of interfaces. Along with incremental interfaces such as TTL / HTL and SinCos there are also absolute interfaces such as SSI and BiSS-C. Absolute encoders with field bus interfaces such as CANopen, PROFIBUS, PROFINET and EtherCAT are also available. The outputs and supply voltage are short-circuit protected.

## Approvals

All encoders from the Kübler company carry the CE mark and are tested for electromagnetic compatibility and immunity to interference. As an option, our products can be UL approved. Many of our products are available on request with EX approval for explosion protection zones 2 and 22 or as product variants for zones 1 and 21. Certified Functional Safety: this permits simple implementation of applications for the protection of personnel. Kübler is active worldwide and considers the protection of the environment as a corporate obligation. Our product range complies with the RoHS directive.



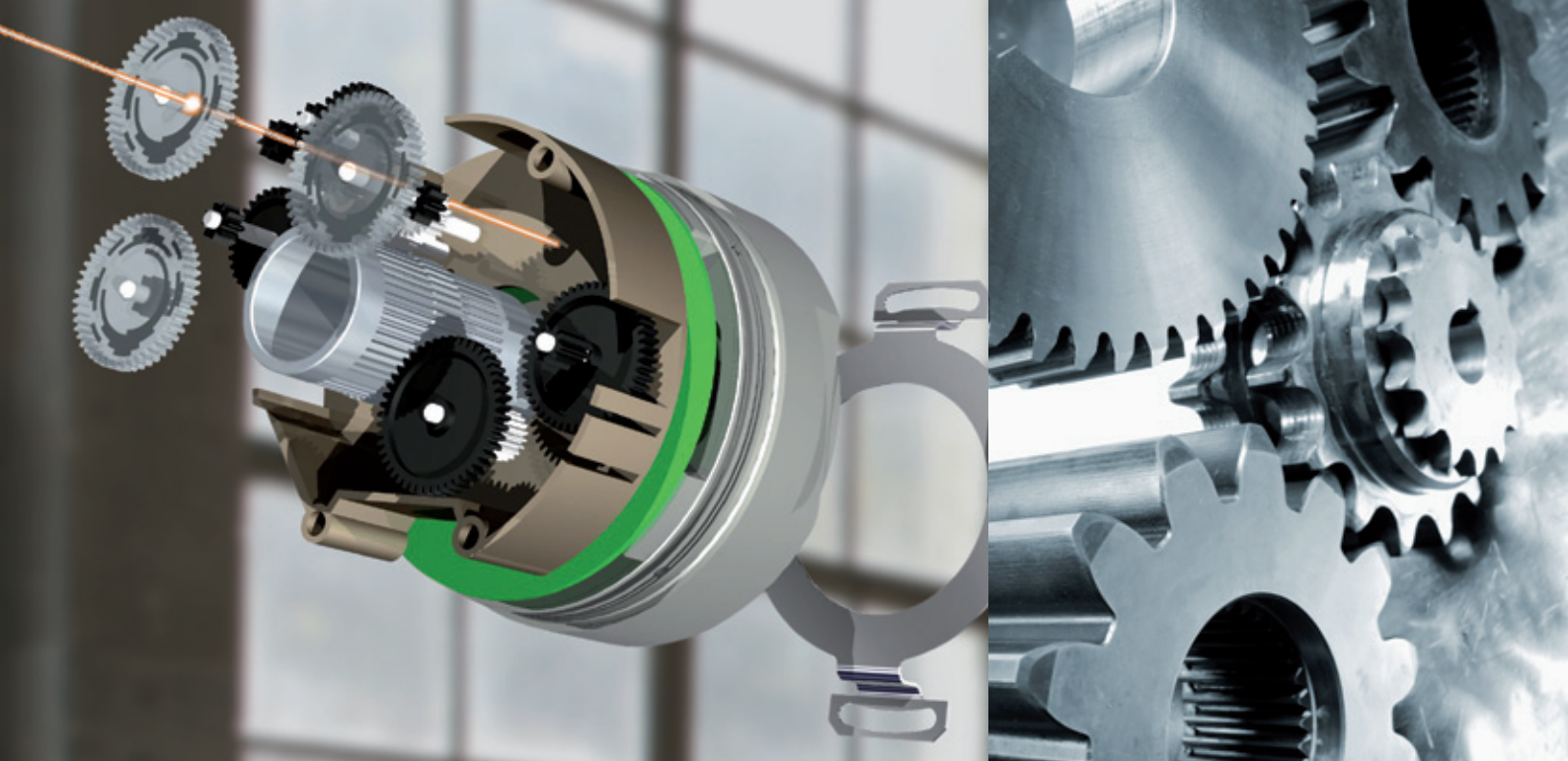

## Robust bearings

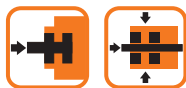

Kübler encoders boast a very sturdy and robust bearing construction, brought together under the term Safety-Lock™. Encoders with Safety-Lock™ have positive interlocked bearings with a large bearing span and special mounting technology. This means they are able to tolerate installation errors as well as large shaft loads, as can occur as a result of temperature expansion or vibration.

A further development of this technology is employed in the Sendix Heavy-Duty encoders (HD-Safety-Lock™).

Encoders are available for use in drive engineering that will operate reliably at speeds of up to 12,000 rpm.

## Shaft isolation



Even well-earthed machine housings and rotors of generators and large motors carry a shaft current on the rotor. The equipotential bonding from the rotor to the stator via the encoder bearings leads to spark erosion and can damage the encoder. This can be remedied by isolating the encoder bearings. Isolating inserts can be used with all Sendix compact encoders. The Sendix H120, for example, has a fully integrated and isolated bearing construction and is tested to a breakdown voltage of 2.5 kV.

## Simple / fast installation



Innovative connection technology with plug-in spring terminal connectors allows for fast, safe installation without tools. Maximum connection safety with minimal connection times.

## Housing geometry



The compact design dimensions specially conceived for drive engineering as well as the very compact connector solution permit optimal integration on/under fan cowls. The tangential cable outlet, for example, is ideal where installation space is tight. The through hollow shaft of the Kübler encoders leaves ample clearance for other motor options, even behind the encoder. In order to ensure the easiest possible mounting onto the motor, various mounting options are available for both solid shaft and hollow shaft variants, including, for example, clamping flanges, stator couplings and tether arms.

## Hardened down to the last detail



The durable construction that comes as standard, permits high shock and vibration values; these are both tested and certified. The values are extremely important in drive engineering, as the potential applications for the motors are highly diverse. Dual seal protection on the shaft side, for example with the Sendix H120, offers increased protection against dust and humidity for harsh operating conditions.

## High protection level / seawater resistant



A high protection level is achieved as a result of the integrated radial shaft seal. This, together with the wide temperature range and the bearing technology, ensures outdoor use is possible without problems. Many versions of the Sendix family of devices have now been tested and certified to IEC 68-2-11 for resistance to the effects of salt-spray over a period of up to 672 hours – the highest test level. The high certification level for the Sendix encoders attests a high level of corrosion resistance.

# Asynchronous motors

Asynchronous motors are the all-rounders amongst electrical drives. For every requirement there is a drive and for every drive there is a suitable Kübler encoder. Whether as a fan motor in a small 63 size, or as a geared motor in a 225 size, asynchronous motors place special demands on encoders, above all when it comes to mechanical and electrical ruggedness. Because of their robust technology Sendix encoders prove themselves, especially in harsh environmental conditions.

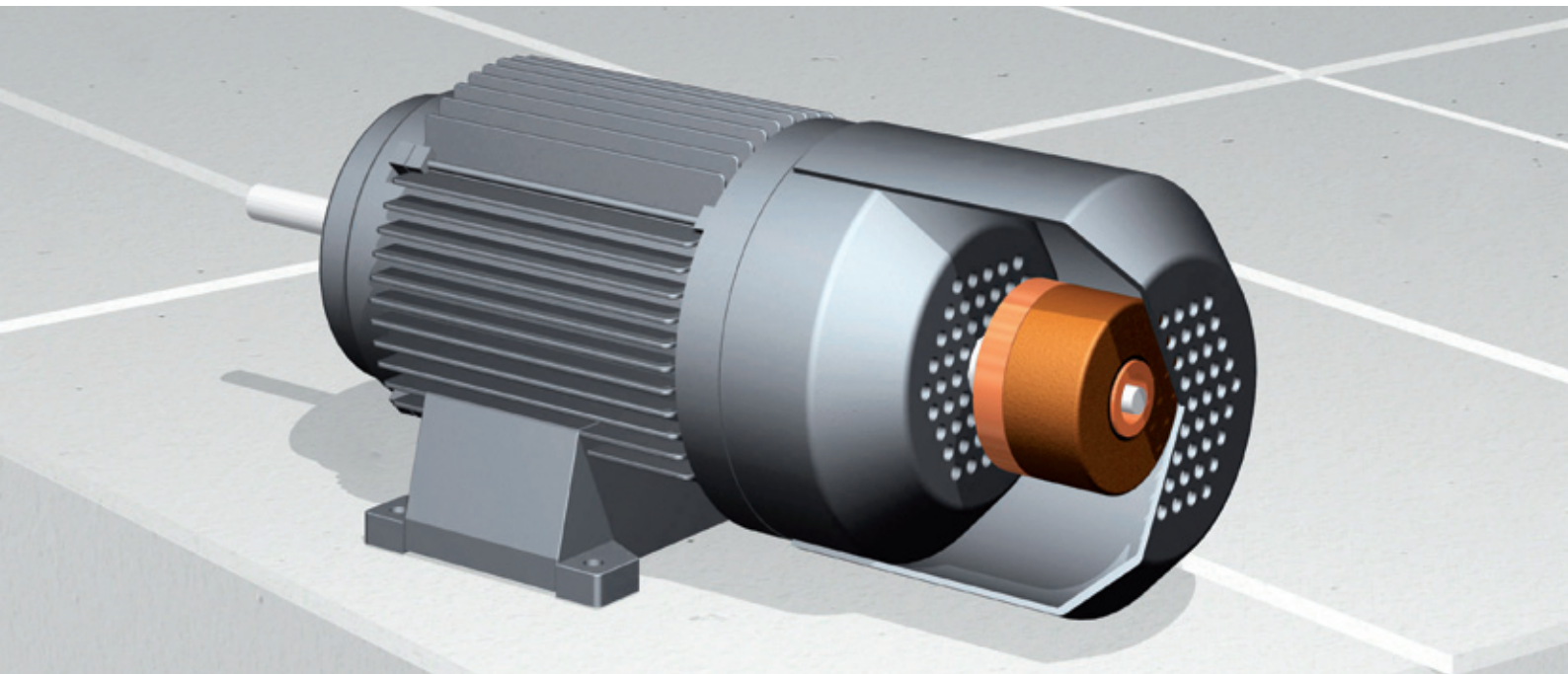

## Application-specific requirements

- Mounting** Especially during the mounting of encoders the mechanics can be overloaded. This can lead to the encoder being prematurely damaged, so that the average service life is not reached.
- Motor options** If a motor next to the encoder is to be equipped with further sensors, then the motor shaft must be fed through the encoder.
- Temperature range** When using asynchronous motors extremely high temperature ranges can occur, which place increased demands on the sensors and on the way they are mounted.
- Magnetic fields** Both the motor and the electromagnetic brakes create stray magnetic fields, which can affect the sensors.

## Kübler solutions (technologies)

(Details see page 4-5)



Safety-Lock™



Through hollow shaft



Wide temperature range



Flexible cable routing



Optical sensor technology for highest accuracy



Magnetic field proof



## Sendix incremental 5000 / 5020

Multitalented device for all types of application, with suitable connector options for every eventuality.

- Compact housing for very tight installation spaces
- Comprehensive range of matching accessories and fixing options
- Increased resistance to vibration and changes of temperature, due to rugged die-cast housing
- Sturdy bearing construction in Safety-Lock™ Design protects against damage during installation and operation
- -40°C up to +85°C, IP67, for use outdoors and in cold stores
- Flexible, with versions suitable for every application: cable connection, connector M12, M16, M23 or MIL
- Optional: seawater resistant, Ex-protection

### Sendix 5000 (shaft)

- Housing  $\varnothing$  50 mm
- Housing depth 47 mm
- Flange  $\varnothing$  58 mm
- Power supply 5 ... 30 V DC

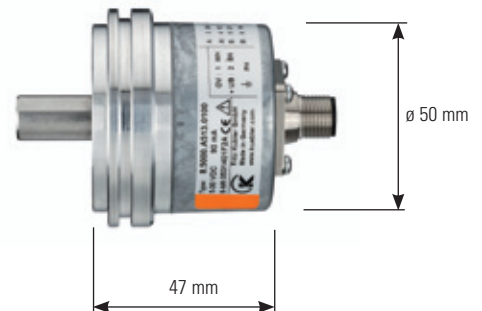

### Sendix 5020 (hollow shaft)

- Housing  $\varnothing$  50 mm
- Housing depth 37.5 mm
- Through hollow shaft,  $\varnothing$  up to 15.87 mm (5/8")
- Stator coupling
- Power supply 5 ... 30 V DC

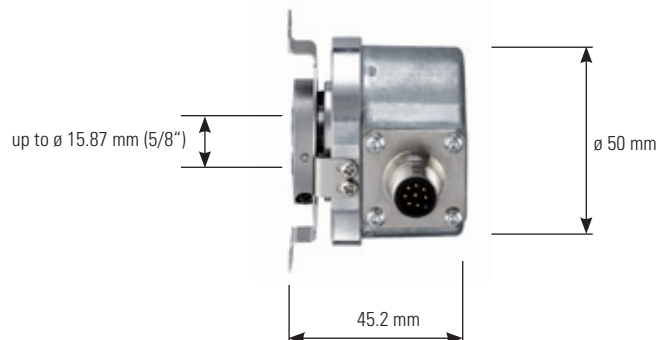

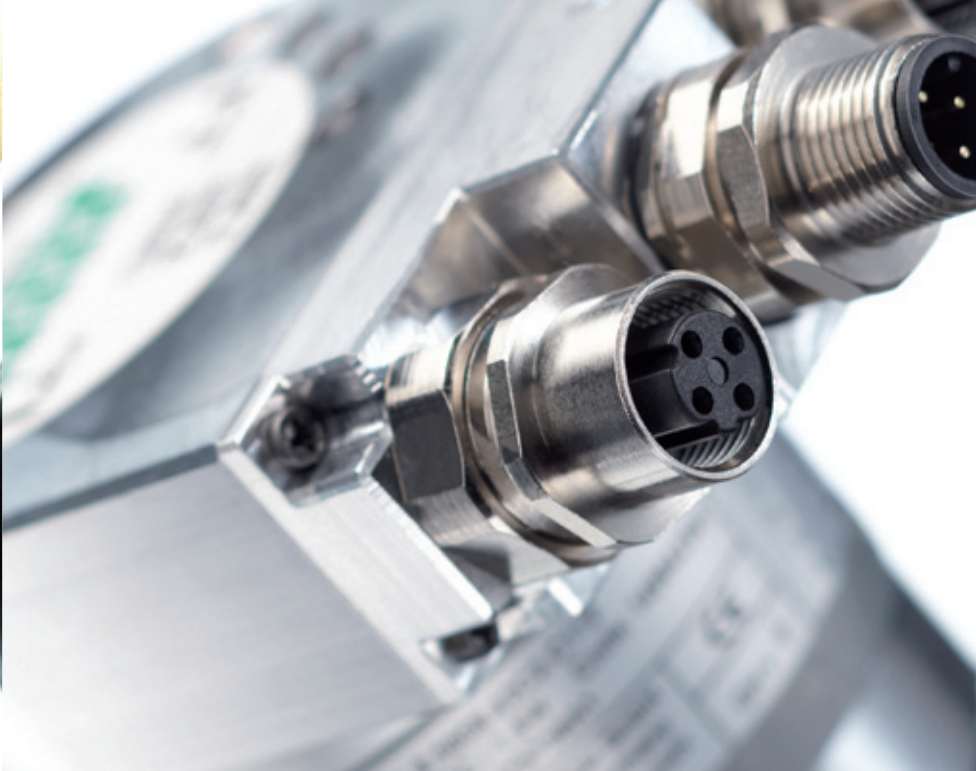
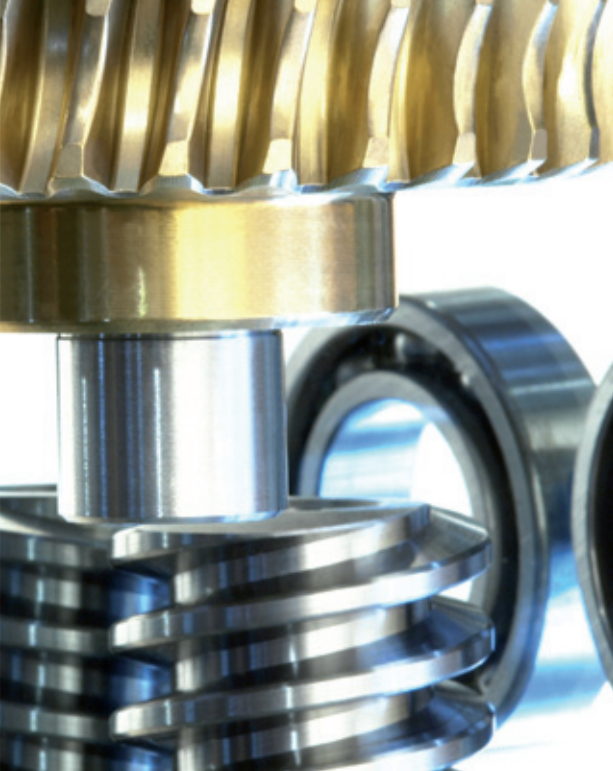

## Absolute encoder family: Sendix 58

Whether integrated into the drive or as a stand-alone measuring system: the proven Sendix absolute encoders with mechanical gear in the standard 58 mm size are just as robust as high-precision measuring systems.

- Accurate optical scanning, 100 % magnetic insensitivity
- No battery needed to store the number of revolutions
- Up to 17 bits singleturn and 12 bits multturn resolution
- Interfaces: SSI, BiSS-C, CANopen, PROFIBUS, PROFINET and EtherCAT
- With additional incremental outputs RS422 and SinCos
- -40°C up to +90°C with protection level IP67
- Robust Safety-Lock™ Design bearing construction
- Simple diagnostic options by means of LEDs
- Through hollow shaft up to 15 mm



	<b>Sendix 5853 / 5873</b>	<b>Sendix 5858 / 5878</b>	<b>Sendix 5863 / 5883</b>	<b>Sendix 5868 / 5888</b>
Application	Shaft / Hollow shaft Singleturn encoder with standard interface for connection to the inverter	Shaft / Hollow shaft Singleturn encoder with field bus interface for connection to the PLC	Shaft / Hollow shaft Multiturn encoder with standard interface for connection to the inverter	Shaft / Hollow shaft Multiturn encoder with field bus interface for connection to the PLC
Interface	SSI or BiSS-C	CANopen, PROFIBUS, PROFINET or EtherCAT	SSI or BiSS-C	CANopen, PROFIBUS, PROFINET or EtherCAT
Resolution max.	17 bits	16 bits	17 bits ST + 12 bits MT	16 bits ST + 12 bits MT
Motor connection	Shaft max. 10 mm Hollow shaft max. 15 mm	Shaft max. 10 mm Blind hollow shaft max. 15 mm	Shaft max. 10 mm Blind hollow shaft max. 15 mm Hollow shaft max. 14 mm	Shaft max. 10 mm Blind hollow shaft max. 15 mm
Speed max.	12000 rpm	12000 rpm	12000 rpm	9000 rpm
Temperature range	-40 ... +90°C	-40 ... +80°C	-40 ... +90°C	-40 ... +80°C
Power supply	5 V DC 10 ... 30 V DC	10 ... 30 V DC	5 V DC 10 ... 30 V DC	10 ... 30 V DC



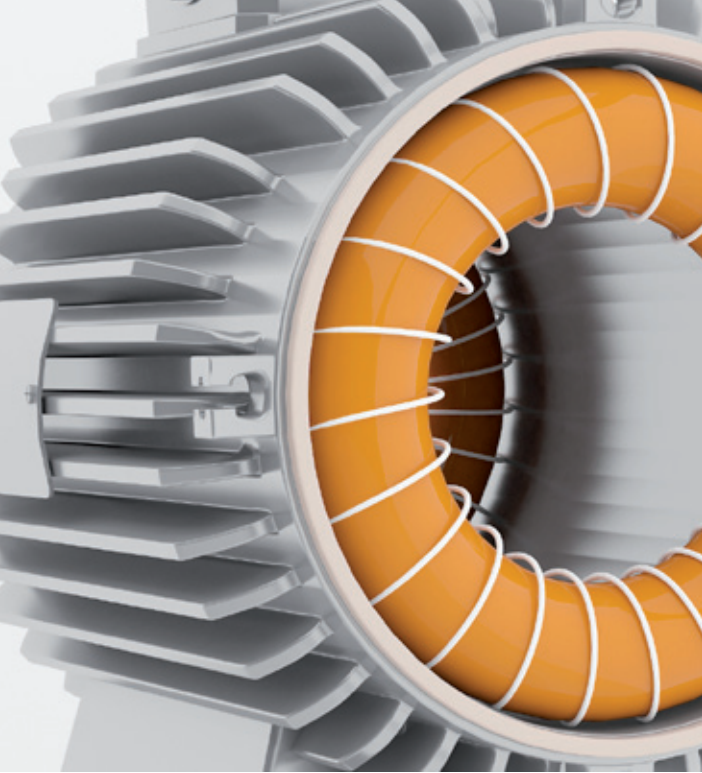

## Absolute encoder family: Sendix F36 and Sendix F58

The award-winning patented Intelligent Scan Technology™ lies at the heart of the Sendix absolute family of encoders F36 and F58 from Kübler.

The optical encoder has integrated all the singleturn and multiturn functions onto one OptoASIC. This allows the sensor technology to achieve the highest levels of reliability as well as very high resolution. With a singleturn resolution of up to 17 bits and a multiturn resolution of up to 24 bits the encoder is able to reach a new peak of 41 bits total resolution.

In addition, the Intelligent Scan Technology™ ensures 100 % magnetic insensitivity whilst at the same time offering low-power consumption sensor technology.

High reliability is also guaranteed when it comes to the mechanical side (extremely rugged zinc die-cast housing, robust Safety-Lock™ bearing construction).



	<b>Sendix F3653 / F3673</b>	<b>Sendix F3663 / F3683</b>	<b>Sendix F5863 / F5883</b>
Application	Shaft / Hollow shaft Compact singleturn encoder with standard interface for connection to the inverter	Shaft / Hollow shaft Compact multiturn encoder with standard interface for connection to the inverter	Shaft / Hollow shaft Robust singleturn encoder with standard interface for connection to the inverter
Interface	SSI or BiSS-C (also as version with CANopen)	SSI or BiSS-C (also as version with CANopen)	SSI or BiSS-C
Size	ø 36 mm	ø 36 mm	ø 58 mm
Resolution max.	17 bits	17 bits ST + 24 bits MT	17 bits ST + 24 bits MT
Motor connection	Shaft max. 10 mm Blind hollow shaft max. 10 mm Hollow shaft max. 8 mm	Shaft max. 10 mm Blind hollow shaft max. 10 mm Hollow shaft max. 8 mm	Shaft max. 10 mm Hollow shaft max. 15 mm
Temperature range	-40 ... +90°C	-40 ... +90°C	-40 ... +85°C
Power supply	5 V DC 10 ... 30 V DC	5 V DC 10 ... 30 V DC	5 V DC 10 ... 30 V DC

# Large motors / Generators

A tough nut. Accurate speed information is an important measurement for the control loop of a plant. Measuring systems that supply this information are often subjected to harsh environmental conditions but must not suffer any loss of reliability.

Kübler incremental encoders can handle strong vibration or extreme variations in temperature without any problem. Here, their wide-ranging mounting options guarantee easy, safe installation.

Kübler offers the complete range of solutions, from the extremely rugged Sendix Heavy Duty through to the compact, bearing-free Limes encoder systems.

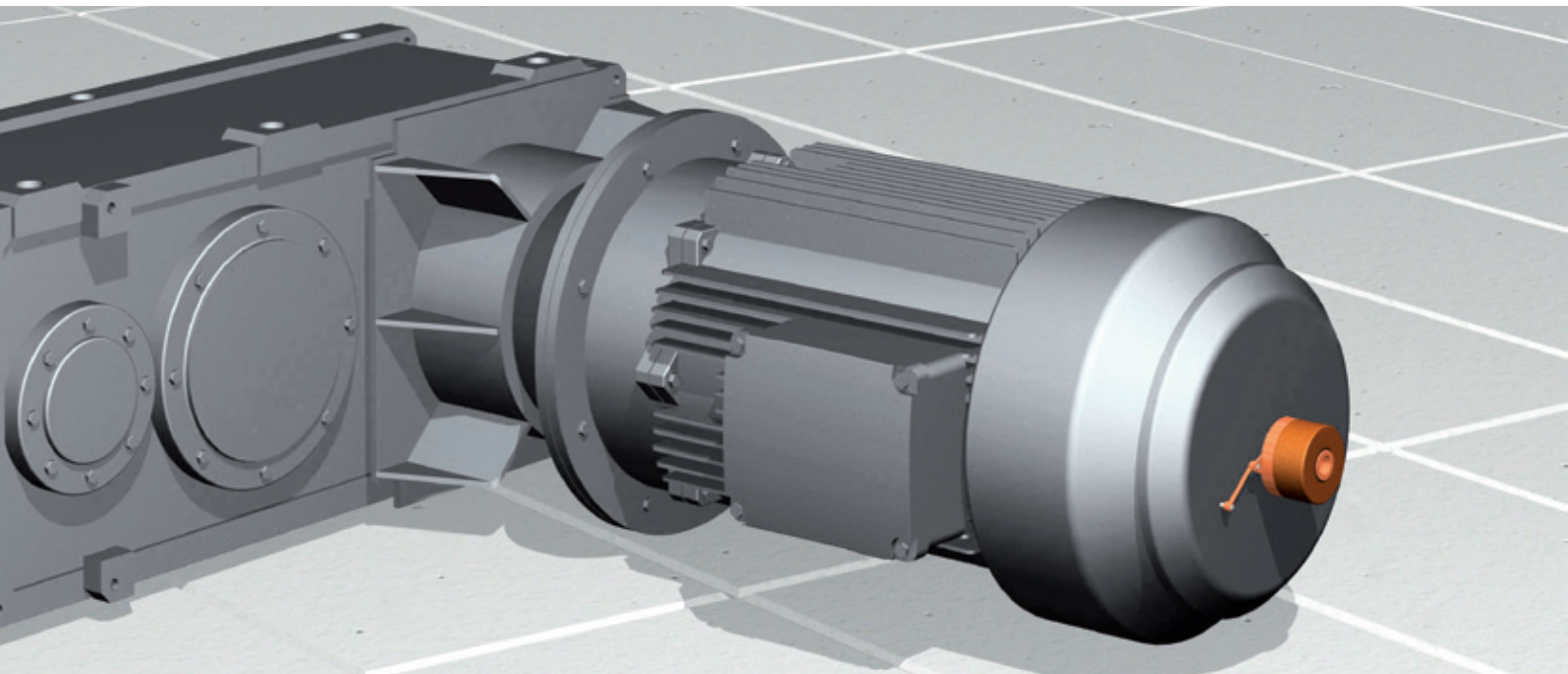

## Application-specific requirements

### Ruggedness

The ruggedness of the sensor technology plays a crucial role with large drives. Shocks and impacts encountered in this class of drives are higher than elsewhere.

### Service life / Maintenance

In applications where large motors or generators are used, downtimes are very expensive; for this reason maintenance and any replacement of a component must be very simple.

### Weather and environmental conditions

Large motors are employed primarily in harsh environments. The protection class of the sensors is thus correspondingly important, so that breakdowns can be avoided.

### High currents

Despite well-earthed machine housings, generators and large motors carry a certain shaft current on the rotor. The equipotential bonding from the rotor to the stator via the encoder bearings can damage the encoder.

## Kübler solutions (technologies)

(Details see page 4-5)



HD-Safety-Lock™



Shock / vibration resistant



Plug-in spring terminal connectors



No need for tools



Dual protection of the shaft



High protection level



Integrated bearing isolation up to 2.5 kV for a reliable shaft connection

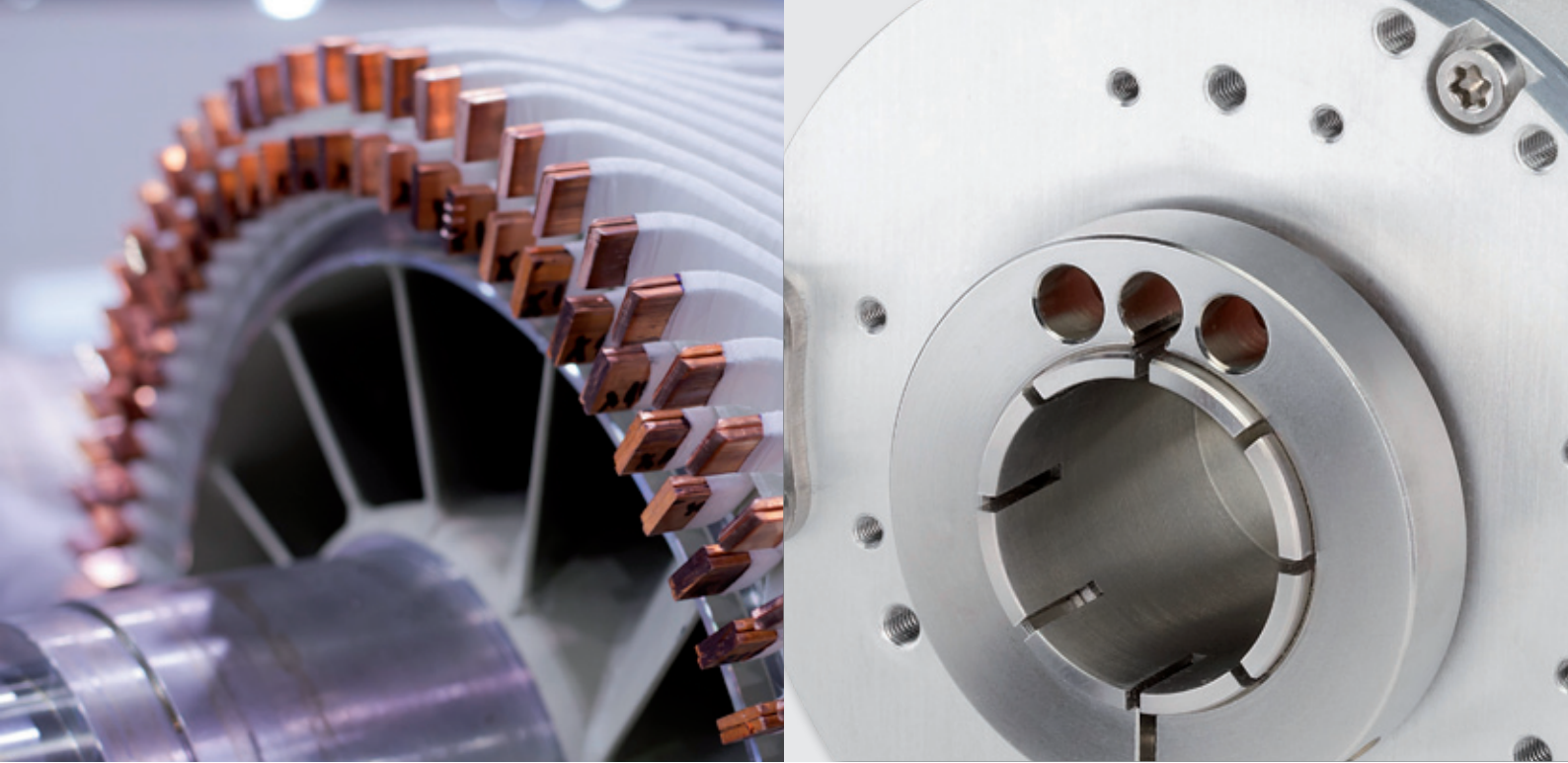

	5821	A020 / A02H	Sendix H100 / H120	Limes LI50 / RI50
Application	Hollow shaft Compact encoder for large motors, with extremely smooth running and for use in confined installation conditions	Hollow shaft For narrow installation areas and for applications with increased bearing loads	Shaft / Hollow shaft Heavy Duty encoder for applications with high bearing loads and very high shaft currents	Hollow shaft Bearing-free encoder for very tight installation situations (only 10 mm depth)
Size	ø 58 mm	ø 100 mm	ø 100 / 115 mm	40 x 25 mm
Resolution max.	5000 ppr	5000 ppr	5000 ppr	3600 ppr
Motor connection	Hollow shaft max. 28 mm	Hollow shaft max. 42 mm	Shaft max. 11 mm Hollow shaft max. 28 mm	Hollow shaft max. 35 mm
Speed max.	2500 rpm	6000 rpm	6000 rpm	12000 rpm
Temperature range	-20 ... +70°C	-40 ... +80°C	-40 ... +100°C	-20 ... +80°C
Power supply	5 V DC 8 ... 30 V DC	5 V DC 5 ... 30 V DC 10 ... 30 V DC	5 V DC 5 ... 30 V DC 10 ... 30 V DC	4,8 ... 30 V DC

## **i** HD-Safety-Lock™ – hollow shaft (Sendix H120)

**Heavy Duty hollow shaft design of the latest generation – extremely robust with integrated shaft isolation**

- Extremely robust flange mounting due to screw-on housing
- Extremely robust bearing construction due to
  - mechanically interlocked bearings
  - use of very large highly robust bearings
  - large bearing span
- Maximum level of protection against dust and humidity due to:
  - shielding cover disk on the shaft
  - high quality radial shaft seal
- Bearing design incorporates integrated isolation (isolating inserts not required), tested up to 2.5 kV for high running accuracy; metal to metal connection for slip free mounting

# Synchronous motors

The family of synchronous motors includes very small motors, as well as stepper motors, dynamic servo motors and very powerful gearless drives.

Stepper motors are very small drives for lower performance ranges. Kübler encoders are perfect for these applications because of their compact size and design.

Servo motors are drives for high precision and dynamics with permanent magnet technology and very compact size and design.

Gearless drives are used, wherever gear reduction can be dispensed with by optimising the direct chain. Gearless drives have a very high number of poles and in consequence a slow final speed with very high torque levels.

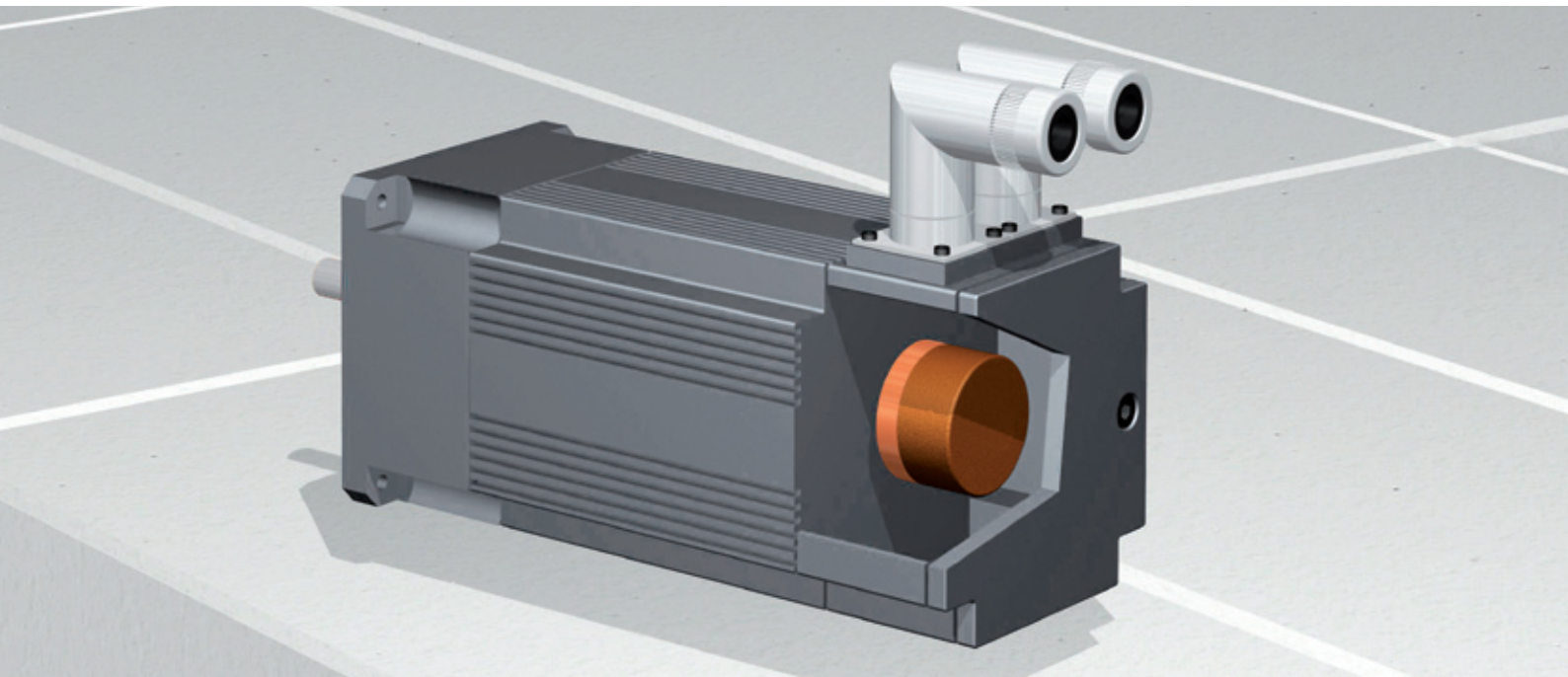

## Application-specific requirements

### Installation

The small size of the motors means that every millimetre counts. For this reason it is important to use sensors that are compact but nevertheless of high performance.

### Commutation

In order to ensure effective control of servo motors, it is important to have exact information concerning the position of the rotor. This can be provided by either a singleturn or multiturn encoder.

### Temperature range

The self heating of powerful synchronous motors can notably lead to high ambient temperatures. Because of the high degree of integration of the sensor technology into these drives, the encoders are more directly exposed to the high temperatures than is the case with other motors.

### Accuracy

Good control, especially with a high number of poles, requires high accuracy of the encoder.

## Kübler solutions (technologies)

(Details see page 4-5)



Size



BiSS interface



Absolute encoder disc



Wide temperature range



Optical sensor technology for highest accuracy



Magnetic field proof



## Encoders for stepper motors

Whenever a high resolution in very tight installation conditions is called for, then the miniature encoders from Kübler are the ideal choice.



	<b>2400 / 2420</b>	<b>2430 / 2440</b>	<b>3610 / 3620</b>	<b>3700 / 3720</b>
Application	Shaft / Blind hollow shaft Incremental miniature encoder with optical sensor	Shaft / Blind hollow shaft Incremental miniature encoder with magnetic sensor	Shaft / Hollow shaft Incremental compact encoder with optical sensor	Shaft / Hollow shaft Incremental economy encoder with optical sensor
Interface	Push-pull	RS422	Push-pull, RS422	Push-pull, RS422
Size	ø 24 mm	ø 24 mm	ø 36 mm	ø 37 mm
Resolution max.	1024 ppr	256 ppr	2500 ppr	1024 ppr
Motor connection	Shaft max. 6 mm Blind hollow shaft max. 6 mm	Shaft max. 6 mm Blind hollow shaft max. 6 mm	Shaft max. 6,35 mm Hollow shaft max. 8 mm	Shaft max. 8 mm Hollow shaft max. 8 mm
Speed max.	12000 rpm	12000 rpm	12000 rpm	6000 rpm
Temperature range	-20... +85°C	-20... +85°C	-20 ... +85°C	-20 ... +70°C
Power supply	5 ... 24 V DC 8 ... 30 V DC	5 ... 24 V DC	5 ... 18 V DC 8 ... 30 V DC	5 V DC 5 ... 30 V DC 10 ... 30 V DC

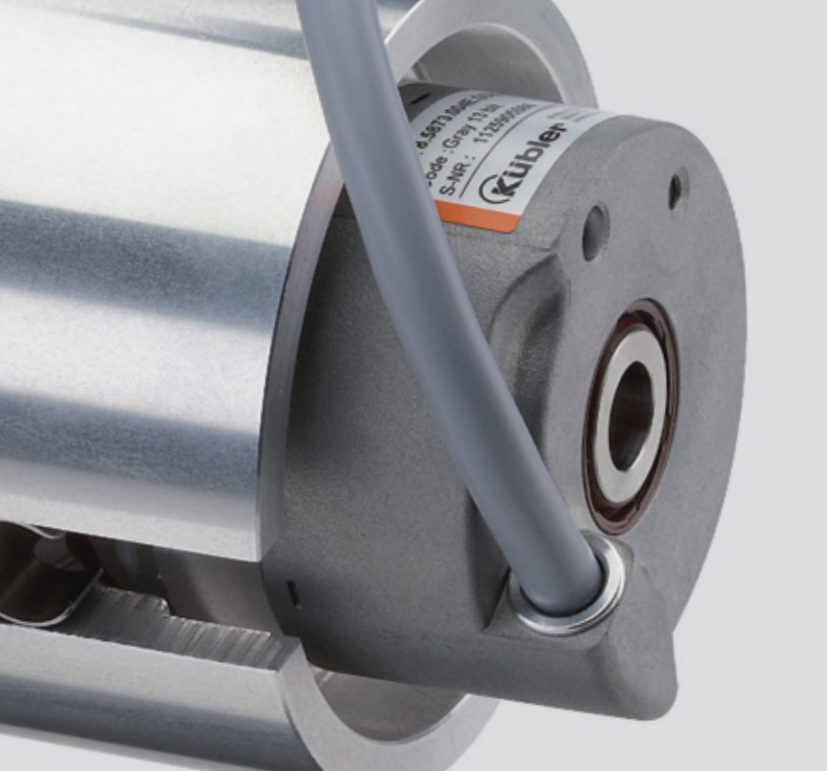

## Encoders for dynamic servo motors

Servo motors impress with their high dynamics and their level of performance.

These characteristics can only be achieved if the servo amplifier can optimally control the motor. For this it requires high performance sensors such as the encoders from Kübler.



	2450 / 2470	Sendix F3653 / F3673
Application	Shaft / Blind hollow shaft Miniature encoder with 12 bits resolution for very small motors	Shaft / Hollow shaft Absolute encoders for high performance with up to 17 bits resolution
Interface	SSI or BiSS-C	SSI or BiSS-C (also as version with CANopen)
Size	ø 24 mm	ø 36 mm
Resolution max.	12 bits	17 bits
Motor connection	Shaft max. 6 mm Blind hollow shaft max. 6 mm	Shaft max. 10 mm Blind hollow shaft max. 10 mm Hollow shaft max. 8 mm
Speed max.	12000 rpm	12000 rpm
Temperature range	-20 ... +85°C	-40 ... +90°C
Power supply	5 V DC	5 V DC 10 ... 30 V DC



## Encoders for gearless drives

Gearless drives are the logical further development of a geared servo motor. They are increasingly used, for example, in lift technology, where torque is already required at zero speed. This can be achieved by using high resolution sensor technology, such as can be provided by the encoders from Kübler.



### **i** Diagnostics and maintenance

Small details make installation and maintenance simpler: the Sendix absolute encoders have a SET button integrated into the housing. This allows setting of the reference position via a simple push of a button. This functionality can also be carried out easily via the interface. The integrated status LED displays the current status of the encoder, which is especially helpful during maintenance work.



	Sendix 5863 + resolver	Sendix 5873
Application	Shaft Absolute encoders with additional resolver signal, motor feedback and positioning encoder in one device	Hollow shaft Compact absolute encoder with innovative torque stop
Interface	SSI or BiSS-C + resolver signal	SSI or BiSS-C + incremental SinCos track
Size	ø 58 mm	ø 58 mm
Resolution max.	17 bits ST + 12 bits MT	17 bits
Motor connection	Shaft max. 10 mm	Hollow shaft max. 15 mm
Speed max.	12000 rpm	12000 rpm
Temperature range	-40 ... +90°C	-40 ... +90°C
Power supply	5 V DC 10 ... 30 V DC	5 V DC 10 ... 30 V DC

# Explosion protection – ATEX

In hazardous areas encoders must comply with special protective regulations, as even the smallest spark can have very serious consequences.

Positioning tasks occur in many hazardous environments – whether in mining, in the chemical industry or also in oil production.

Especially for those applications that require absolute position values, Kübler offers the Sendix absolute encoders with ATEX approval. The singleturn and multiturn ATEX encoders with “flame-proof-enclosure” housings are approved for zones 1, 2, 21 and 22 and certified by the PTB (German national metrology institute) according to the ATEX guidelines and IEC EX standards.



## Sendix ATEX encoders

The shock and vibration-resistant ATEX encoders operate flexibly with a resolution of up to 17 bits (singleturn) and 29 bits (multiturn). In addition the incremental version supplies a push-pull, RS422 or SinCos signal. With their IP67 protection level and wide temperature range of -40°C up to +60°C, the ATEX encoders remain sealed even under the rigours of tough everyday use and offer good security against failures in the field. Thanks to the housing and flange made of seawater-resistant aluminium they are ideal for use in offshore and coastal applications. The compact design with an installation depth of only 145 mm, a diameter of 70 mm and a space-saving cable outlet round off the diverse, flexible options for use in hazardous EX areas.

### Incremental encoders

Sendix 7030 / 7014SIL

### Absolute encoders singleturn

Sendix 7031 / 7053 / 7058 / 7053SIL

### Absolute encoders multiturn

Sendix 7063 / 7068 / 7063SIL



[www.kuebler.com/atex-encoder](http://www.kuebler.com/atex-encoder)



**new** Sendix 70xxSIL



# Functional Safety Technology - SIL

Safety is – not least since the EU Machinery Directive 2006/42/EC – an “integral part of the construction of drives”. When choosing the right encoder for functional safety the principle applies that safety is achieved through the intelligent combination of encoder, controller and actuator.

But safety goes further than this: safe components are characterised by a robust reliable interface and by the ability to cope with high mechanical and electronic loads. Both Sendix SIL encoders with SSI absolute and additional SinCos interface and also the SinCos version of the incremental encoders have been certified up to SIL3 by the German Institute for Occupational Safety (IFA).



**SIL3**  
Functional Safety  
**PLe**



[www.kuebler.com/safety](http://www.kuebler.com/safety)

## Encoder family for safety technology

In order to achieve safe incremental information with the encoder, the controller must monitor the validity of the analogue, 90° phase-shifted sine/cosine signals with the help of the function:  $\sin^2 + \cos^2 = 1$ .

In order to obtain safe information with the encoder regarding the absolute position, the controller counts the incremental pulses and compares the result with the absolute positions also provided by the encoder.

A 100% reliable mechanical connection is required for a safe function in the applications. Suitably sturdy fixing elements can help eliminate the risk of faults.

### Incremental SinCos encoders:

- Sendix 5814SIL (shaft)
- Sendix 5834SIL (hollow shaft)

### Absolute singleturn SSI / SinCos encoders:

- Sendix 5853SIL (shaft)
- Sendix 5873SIL (hollow shaft)

### Absolute multiturn SSI / SinCos encoders:

- Sendix 5863SIL (shaft)
- Sendix 5883SIL (hollow shaft)

### **i** Multi-talented device:

#### **Absolute encoder with incremental sine/cosine signals, multiturn stage and integrated functional safety**

Drive control using incremental sine and cosine signals is a tried-and-tested technology with a number of advantages. The high interpolatability of the analogue sine and cosine signals, with more than 1 million steps per revolution, allows for precise control of both slow turning as well as highly dynamic drives.

Combined with the high resolution and very accurate position information provided by the absolute encoder, all the data necessary for a precisely controlled motor start-up with an encoder is available. Furthermore, the multiturn sensor technology permits position control over a wide range. And finally, the high information content of the signals – all independent of one another – forms the basis for a sensor with high functional safety.

# Encoder interfaces

Encoders have various tasks to fulfil in drive engineering.

One of the most frequent tasks is to supply information concerning speed, for better control of the motor using a frequency inverter. For this type of speed control motor feedback is necessary, which is suitable for improving the speed quality and the control response. As a rule a SinCos or TTL/HTL signal is used for this purpose.

A further task is the positioning of the drive. This can occur both incrementally as well as absolutely. For dynamic control with synchronous motors, feedback of the rotor position within a revolution is necessary. Singleturn absolute encoders with a BiSS-C or SSI interface are used to achieve this.

## Overview of interfaces for motor feedback

The electrical interfaces of an encoder are important for good integration into a drive system. The necessary information can be derived from the requirements and the type of motor as well as from the transmission interface.

Higher interpolation can be achieved by the use of signal inversion. A cyclic reference signal can be output by use of an optical pulse track (C-signal).

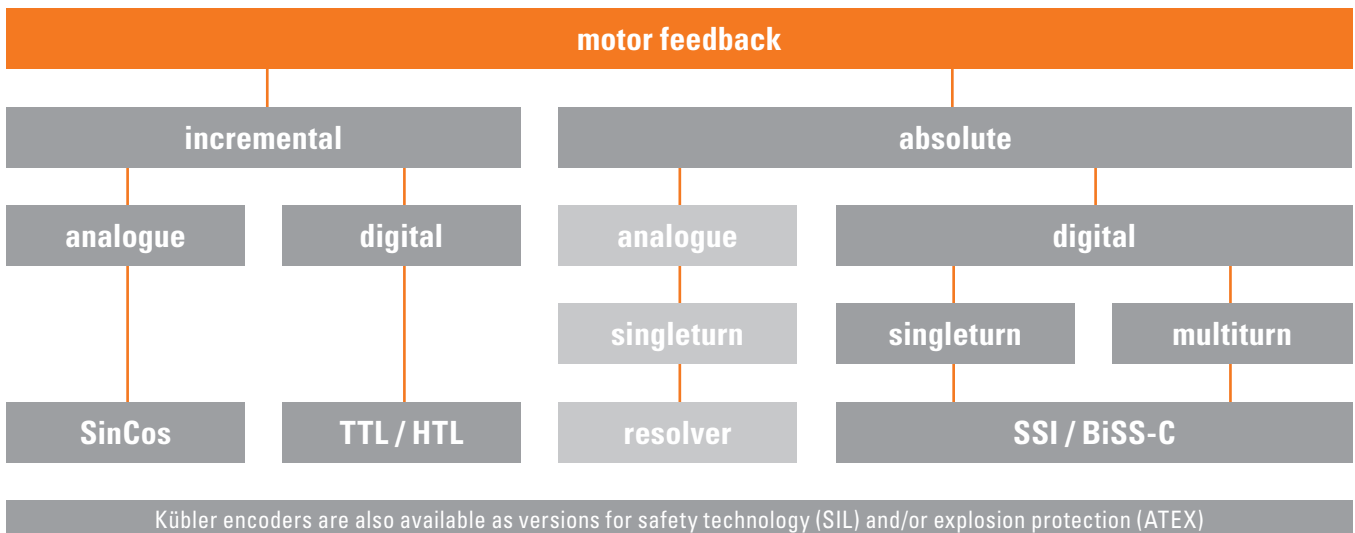

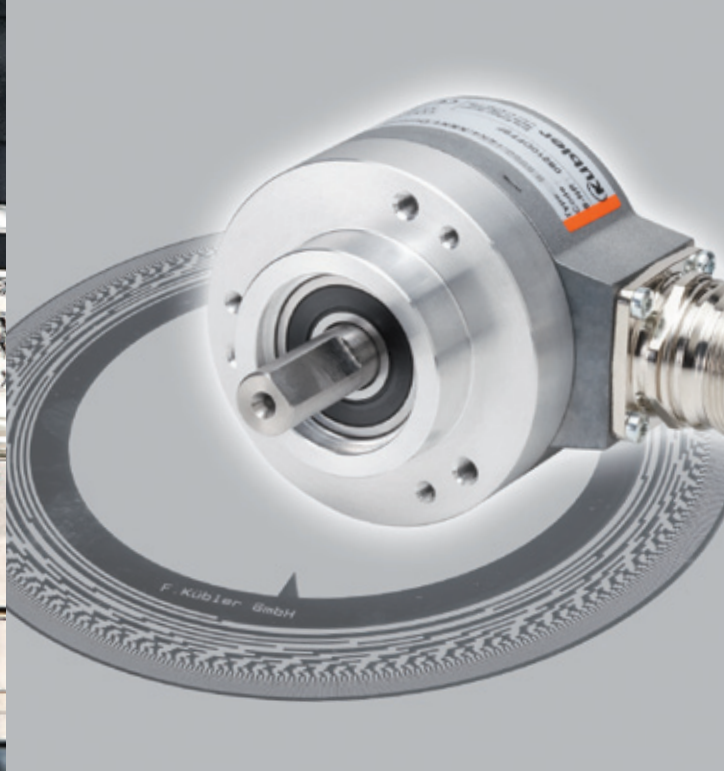
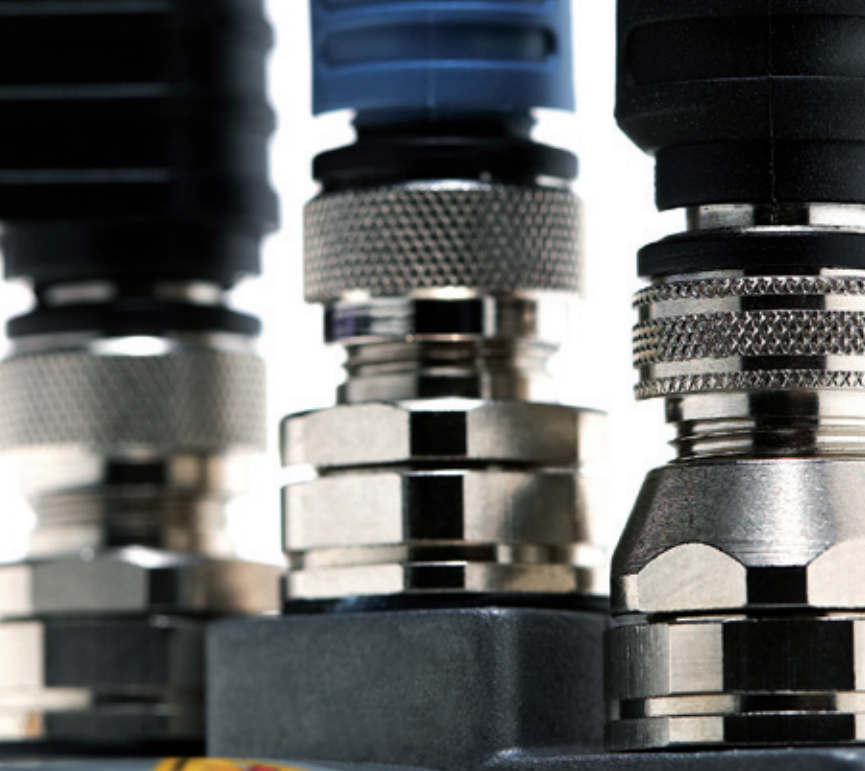

## BiSS-C interface

The Open Source BiSS-C (Bidirectional/Serial/Synchronous) interface is based on a protocol for achieving a real-time interface for a digital, serial and secured communication between a controller and sensors/actuators. The BiSS-C protocol has been designed for industrial applications, in which transmission speeds, safety (CRC), flexibility and minimized implementation work are required.

As they are only framed by a start and a stop bit, the sensor data is transferred at the best possible user data rate; a single multi-cycle data bit is optional. Similarly detected and triggered, the multi-cycle data bits form a second inband protocol and contribute to the redundancy of the sensor data – permanent monitoring of the drive status and operation is possible, without interfering with the controller cycle. Specific device developments by individual users are not restricted or made more expensive by a need to be compatible with other BiSS products. A BiSS subscriber is described with only a few parameters and an XML device description file that comes with the product simplifies the startup of the controller.

Without affecting the payload data of measurements or interfering with control cycles the communication protocol incorporates a permanent, bidirectional access to slave registers. That way device parameters and additional measurement data, or an electronic ID plate and OEM data, can be accessed at any time – device monitoring and diagnosis is made easy.

## SSI interface

Compared to the parallel interface, the SSI interface needs less components and the EMC-characteristics are much better. In addition less lines are needed for transmission and the possible cable length is much longer.

At rest, the clock and data lines are at a high level. With the first falling clock-pulse edge, the current encoder data are stored in the buffer ready to be sent. With the next rising clock-pulse edge, the data are transmitted bit by bit, starting with the MSB. The transfer of a complete data word requires  $n+1$  rising clock-pulse edges ( $n$ =resolution in bit), e.g. 14 clock signals for a complete readout of a 13 bit encoder.

After the last positive-going clock-pulse edge the data line will remain for the duration of the monoflop time  $t_3$  at a low level, until the encoder is ready for a new data word. The clock line must stay high for at least as long, and then can begin a new read-out sequence again with the next falling edge.

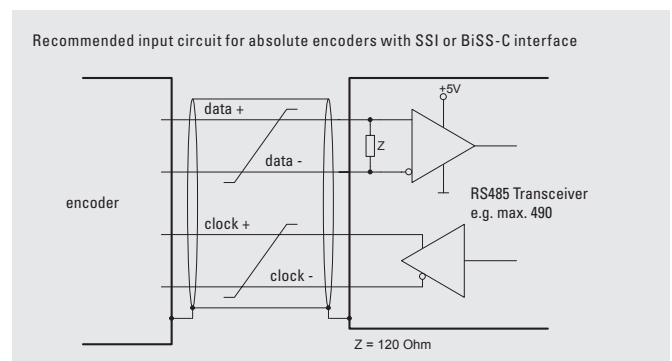

**BiSS**  
INTERFACE

[www.kuebler.com/biss-c-interface](http://www.kuebler.com/biss-c-interface)



**SSI**

[www.kuebler.com/ssi-interface](http://www.kuebler.com/ssi-interface)

# Fixing and connection solutions

Perfect integration into the drive can only be successful if an optimal connection of the encoder to the motor is made.

For the rotating motor shaft and motor housing Kübler offers a wide choice of standard fixing and connection options, with which the desired encoder variants can be combined in a modular design principle. In addition to this individual, customised solutions can be worked out.

## Fixing on the motor housing

### Fastening arm

For applications with axial and radial play with constant rotary movements.



### Stator coupling

For applications with axial and radial play with high dynamics.



### Tether arm

For applications with low axial and radial play, flexible in use



### Individual fixing solutions

#### e.g. ez Fan-clip – Mounting solution on fan grill

For instant easy fixing of the encoder directly onto the fan grill of the gear housing



## Fixing to the motor shaft

### Shaft

Simple mounting on various shaft diameters via suitable couplings

- Easy to centre
- Long service life
- Max. tolerance
- High speed



### Hollow shaft

Accurate centring and reduced vibration

- Long service life
- Max. tolerance
- High accuracy



## i Couplings for shaft fixing

### Metal bellows couplings

Metal bellows couplings are the inexpensive option especially for compensating larger axial errors.

### Spring washer couplings

Spring washer couplings are used primarily where high speeds and minimal axial errors occur.

For applications, where electrical isolation between the encoder and the drive is desired, the electrically isolating spring washer coupling should be used.

### Paguflex couplings

The safe, uncomplicated and economical solution, if drive shafts with angular, radial and/or axial displacement are to be friction-locked together.





Additional accessories at: [www.kuebler.com/accessories](http://www.kuebler.com/accessories)  
 Additional connection technology at: [www.kuebler.com/connection\\_technology](http://www.kuebler.com/connection_technology)

## Connection solutions

### Standard connection solutions

- PCB plug-in connectors: M12, M23, MIL
- Cable connection
- Terminal box
- Optical fibre signal transmission technology



### Individual connection solutions

Kübler offers space-saving installation options for M12 and M23 connectors under the fan cowl.

- Lead-through M12 straight, IP67
- Male connector with external thread, IP67, central fastening



## Accessories connection technology

### Cables

All cables – for incremental, absolute and field bus encoders – can also be ordered by the metre as open-ended cable:

- PVC and PUR cables
- Halogen-free cables
- Bus cables

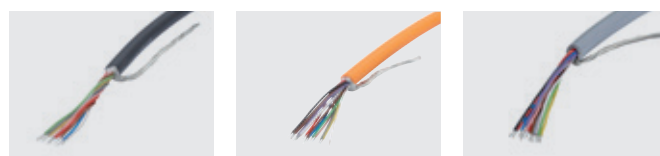

### Connectors

Kübler offers a range of connectors for self-assembly with a protection level of up to IP67, for example as male connector M23 with external thread or as socket with metal union nut.



### Cordsets, pre-assembled

Kübler offers pre-assembled cordsets in a variety of connector versions as well as with a different number of cores (5, 8, 10, 12, 18).



---

# Optimal sensor solution thanks to customer-specific development

The ideal sensor for your drive – that is our goal: for simple, fast and error-free mounting – highest reliability of the signals – long service life and minimum costs.

During development of customer-specific solutions Kübler focuses on 3 principles:

- Lean Design (coordinating the materials and functionality to the application)
- Design to Cost (aligning development to target costs)
- Cost of Ownership (fast installation, simple maintenance, long service life)

## Fixing solutions

---

The correct mounting and fixing solution of an encoder in a drive is crucial for reliable operation and peace of mind. The wide variety of drives and the increasing demands placed on drives (especially in respect of installation space) pose new challenges every day.

By the use of intelligent solutions, closely matched to the drive, great savings can be made when it comes to space, time and costs. Furthermore, specific fixing elements can be developed, which are tailored to the installation space of the housing or the geometry of the flange and shaft; this ensures an optimal connection and the highest degree of accuracy.

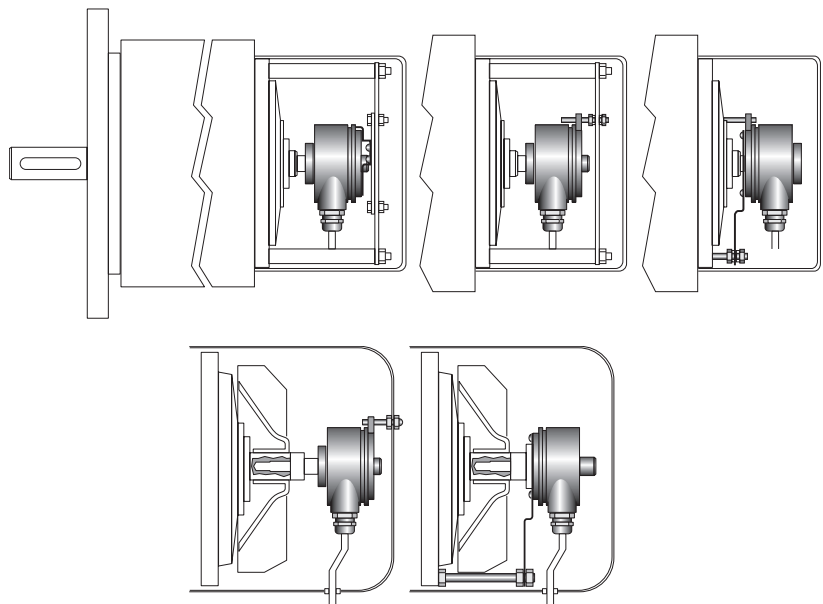

## Connection solutions

---

The cable and connectors used to connect an encoder with the PLC must be matched to the installation space available as well as being capable of withstanding the prevailing environmental conditions such as humidity, cold or heat.

Here too, the setting-up of special cables or the development of specific connectors can lead to the right solution.

In particular, the cable or connector transition from the motor housing to the outside world requires innovative constructions, in order to guarantee reliability and freedom from errors.

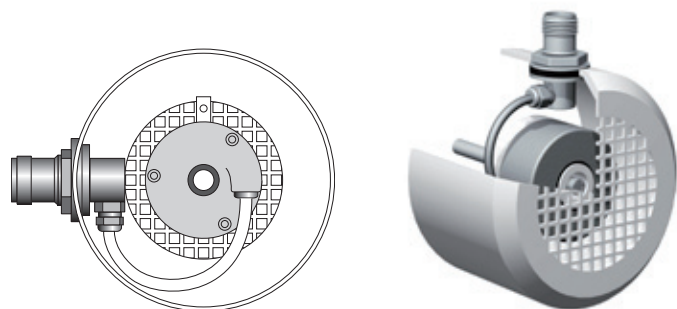

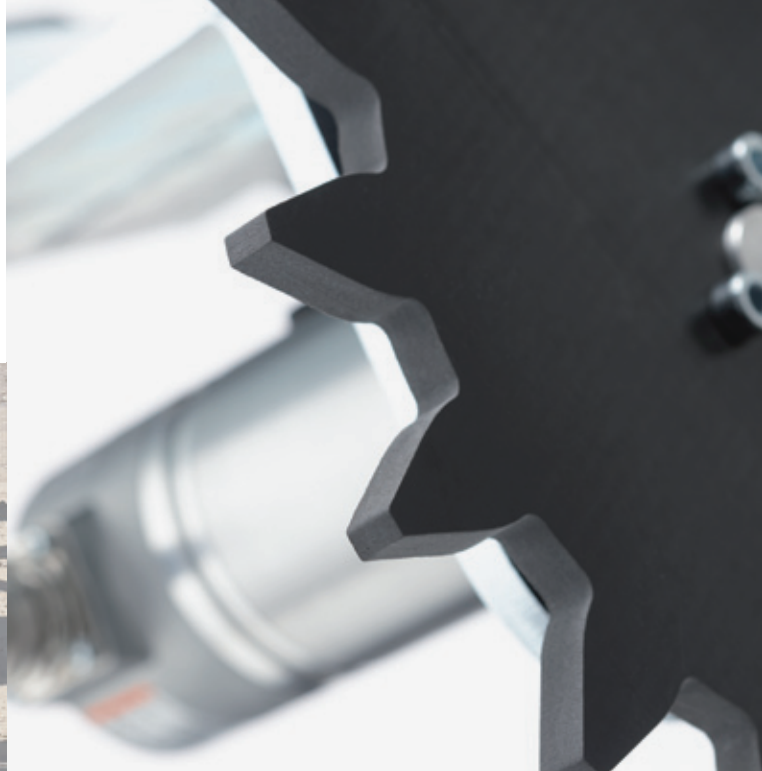
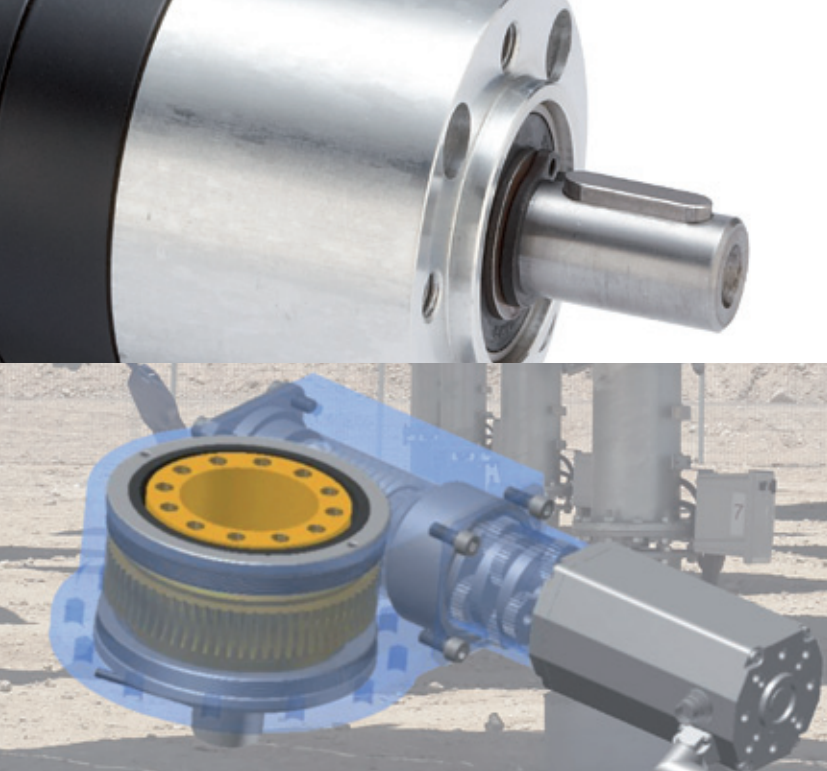

## Protection concepts

---

Kübler does not leave protection of its sensors to chance.

The application areas for drives are very diverse. Kübler has designed appropriate specific protective covers, which take into consideration the design of the encoder, as well as the IP protection level, temperature and operating conditions.

With its extensive experience in difficult application areas, such as steel production, wind turbines or in mobile applications, Kübler has developed special housing and seal designs, as well as coating solutions, which also withstand the high demands of outdoor applications in respect of condensation or extreme fluctuations in temperature.

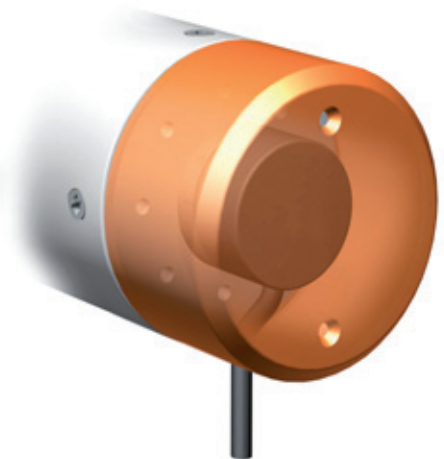

## Advantages of customised integrated drive solutions

---

- High reliability, as all component parts have been specifically designed for your drive
- Particular focus on a longer service life when selecting the product
- Simple, fast mounting thanks to a high degree of integration
- Development of solutions for simple maintenance
- Warranty and support from a single source
- Reduced costs, as the solution is directly tailored to the drive. No "over-engineering".

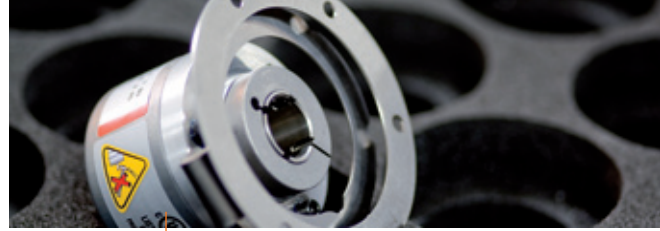

**Presales**

Kübler – the service specialists for every industrial sector and application – supplying complete integrated solutions – globally on your doorstep

Sample Service – Fast delivery of customised versions

Selection tool  
Kübler website: Product Finder

Delivery Service: 10 by 10,  
48 h Express and Repair Service



## Kübler Service for planning dependability

Fast, reliable service and professional advice have top priority at Kübler. We are globally on your doorstep in 6 service and application centres and offer our customers planning dependability.

We deliver from stock within one day. We can manufacture your special orders within 48 hours. Moreover, 10 by 10 is our delivery offensive, which ensures that – for quantities of up to 10 pieces – you will receive all catalogue products so marked within 10 days. Our processes and services are certified and are constantly being improved.

### 10 by 10

With our 10 by 10 Service we will manufacture and deliver 10 encoders within 10 working days (365 days a year - with the exception of 24th Dec. until 2nd Jan.)

The benefits to you: easier to order, the delivery can be calculated, flexibility for small production batches.



### Technical Hotline

Our Hotline will answer your technical questions Mon-Fri within normal working hours:



Kübler GmbH, Germany	+49 7720 3903-35
Kübler France	+33 3 89 53 45 45
Kübler Italy	+39 0 26 42 33 45
Kübler China	+86 10 5134 8680
Kübler India	+91 9819 457 872
Kübler Poland	+48 6 18 49 99 02

### Sample and Repair Service

The Kübler Service Centre can quickly manufacture special, customised versions within a short space of time. We are happy to help you with the practicalities of using our products – at your location if desired. We can carry out repairs within a maximum of 5 working days.



### 48 h Express Service

Short delivery times, a high level of on-time delivery, guaranteed quality and enthusiastic, service-oriented employees – these are what our customers can depend on.

We can process your order within 48 hours; we can ship stock items the same day.







Service Excellence provided by Kübler application specialists for target sectors

Product security – replacement models at the end of the product life-cycle

## Aftersales

Service Centres, globally on your doorstep:  
Advice, analysis, support during installation in over 50 countries

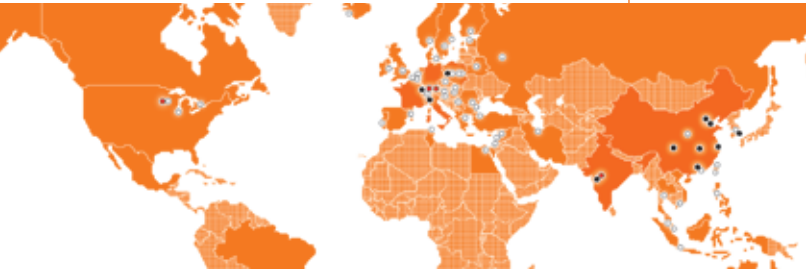

« We were able to considerably reduce our average delivery time and I can confirm that delivery schedules were always adhered to. Technical support is very professional, efficient and not at all bureaucratic. »

*Purchasing Manager, German Producer of Geared Motors*

## Tailor-made solutions – Kübler Design System

« With the KDS method our customers receive a lasting solution to lowering costs, reducing the number of models available or eliminating quality deficiencies. With KDS we develop product and engineering solutions together. The method stands out because of its structured process; this delivers innovation through experience and cooperation with the customer. »

Gebhard and Lothar Kübler, Managing Directors Kübler GmbH

### The Kübler Design System – satisfying customer demands

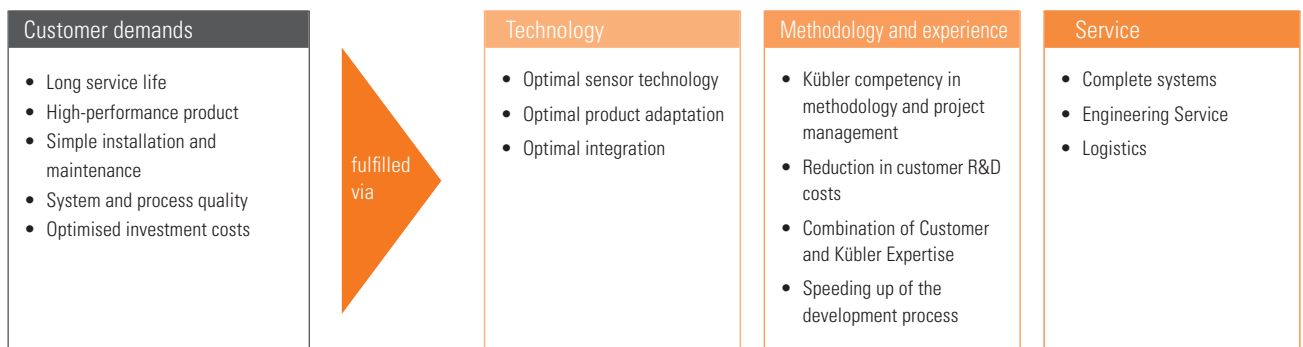

### The 4 phases of the Kübler Design System

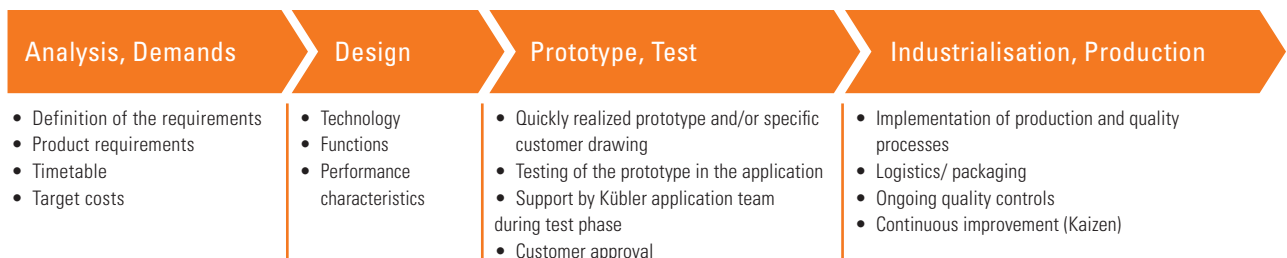

# Product information

We offer additional information on our products and system solutions in the following main catalogues:

## Position and Motion Sensors

- Incremental Encoders
- Absolute Encoders
- Linear Measuring Technology
- Inclinometers
- Connection Technology
- Accessories

Order-No. German **R.100.568**

Order-No. English **R.100.569**



## Counting and Process Devices

- Pulse Counters and Preset Counters
- Timers and Preset Hour Meters
- Frequency Meters and Tachometers
- Combination Time and Energy Meters
- Position Displays
- Process Displays and Controllers
- Temperature Displays and Controllers
- Strain Gauge and Setpoint Adjuster

Order-No. German **R.100.156**

Order-No. English **R.100.157**



## Connector and Signal Transmission Technology

- Slip Rings
- Optical Fibre Signal Transmission Modules
- Cables, Connectors and Cordsets

Order-No. German **R.600.948**

Order-No. English **R.600.948.001**





[www.kuebler.com](http://www.kuebler.com)



[www.kuebler.com/drives](http://www.kuebler.com/drives)



**Kübler Group**  
**Fritz Kübler GmbH**  
Schubertstrasse 47  
D-78054 Villingen-Schwenningen  
Germany  
Phone +49 7720 3903-0  
Fax +49 7720 21564  
info@kuebler.com  
www.kuebler.com

■■■ *pulses for automation*

R.600.195.001 11 450 12 ES