



APEX DYNAMICS, INC.

**PLANETARY GEARBOX
NEW GENERATION P-SERIES**

PSII / PEII / PAII / PGII

PSIIR / PEIIR / PAIIR / PGIIR

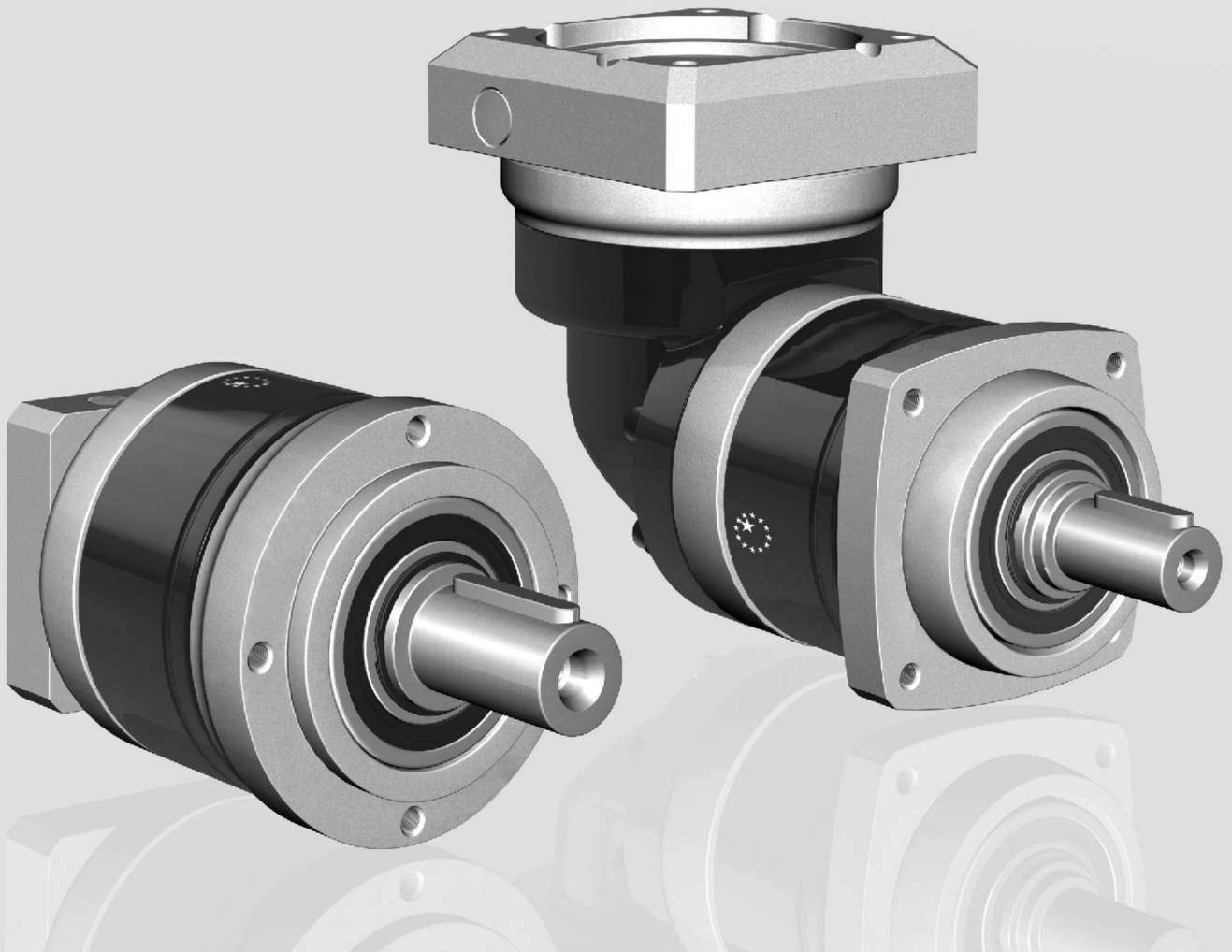

Planetary Gearbox Series

► Features:

- Economic
- High efficiency
- Low noise
- Reduced backlash
- Optimized Inertia moment
- Limited temperature rise
- Long service life
- Flexible mounting diameters
- Minimized size and weight

The perfect servo planetary gearbox !

The brand new APEX PII / PIIR series. The PII / PIIR series is an economic high precision planetary gearbox with excellent performance and quality. Our innovative PII / PIIR series design features minimal size, light weight and high efficiency.



PSII



PEII

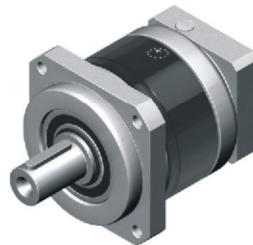

PAII



PGII



PSIIR

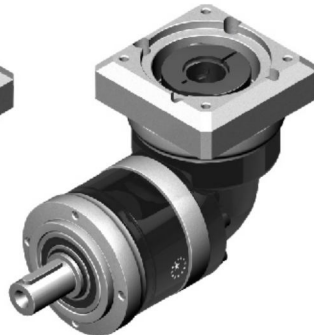

PEIIR



PAIIR

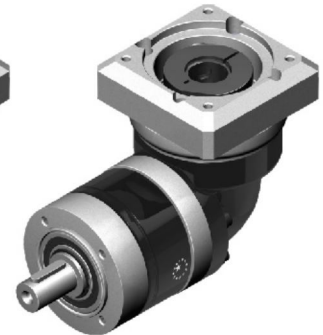

PGIIR

ORDERING CODE

PEII 090 — **010⁽¹⁾** — **()⁽²⁾** / **MOTOR**

PEIIR 090 — **010⁽¹⁾** — **()⁽²⁾** / **MOTOR**

Motor Type :
Manufacturer and Model

Ratio⁽¹⁾:

1-stage: 3, 4, 5, 7, 9⁽³⁾, 10

2-stage: 15, 16, 20, 25, 30, 35, 40, 50, 70, 81⁽³⁾, 100

Gear Size:

PSII: PSII A, PSII B, PSII C, PSII D, PSII E

PAII: PAII 042, PAII 060, PAII 090, PAII 115, PAII 142

PEII: PEII 050, PEII 070, PEII 090, PEII 120, PEII 155

PGII: PGII 040, PGII 060, PGII 080, PGII 120, PGII 160

Ordering Example : PEII090 - 010 / SIEMENS 1FT6 041 - 4AF71

PAII090 - 010 - S1 / SIEMENS 1FT6 041 - 4AF71

Gear Size:

PSIIR : PSIIR A, PSIIR B, PSIIR C, PSIIR D, PSIIR E

PAIIR : PAIIR 042, PAIIR 060, PAIIR 090, PAIIR 115, PAIIR 142

PEIIR : PEIIR 050, PEIIR 070, PEIIR 090, PEIIR 120, PEIIR 155

PGIIR : PGIIR 040, PGIIR 060, PGIIR 080, PGIIR 120, PGIIR 160

Ordering Example : PEIIR 090 - 010 / SIEMENS 1FT6 041 - 4AF71

PAIIR 090 - 010 - S1 / SIEMENS 1FT6 041 - 4AF71

(1) Ratio ($i = N_{in} / N_{out}$).

(2) S1 = Smooth Output Shaft. S1 shaft is only provided for PAII / PAIIR series.

S2 = Output Shaft with Key. This is the standard shaft for PII / PIIR gearbox.

(3) Only provided for PSII/PSIIR and PAII / PAIIR series.

PII Gearbox Performance

Model No.		Stages	Ratio ⁽¹⁾	Type	PSII A	PSII B	PSII C	PSII D	PSII E
					PEII 050	PEII 070	PEII 090	PEII 120	PEII 155
					PAII 042	PAII 060	PAII 090	PAII 115	PAII 142
					PGII 040	PGII 060	PGII 080	PGII 120	PGII 160
Nominal Output Torque T_{2N}	Nm	1	3	All	16	42	110	217	430
			4		16	42	113	223	440
			5		15	40	118	220	435
			7		12	35	96	198	366
			9 ⁽²⁾		8	24	60	125	273
			10		10	27	68	155	295
		2	15		15	40	109	213	424
			16		16	42	116	228	452
			20		16	42	116	230	454
			25		15	40	123	228	450
			30		15	40	108	212	422
			35		12	35	100	206	382
			40		16	43	117	232	459
			50		15	40	123	228	450
			70		12	35	100	206	382
			81 ⁽²⁾		8	24	59	131	285
			100		10	27	70	162	308
			Emergency Stop Torque T_{2NOT}		Nm	1,2	3~100	All	3 times T_{2N}
Max. Acceleration Torque T_{2B}	Nm	1,2	3~100	All	$T_{2B} = 60\%$ of T_{2NOT}				
No Load Running Torque ⁽⁵⁾	Nm	1	3~10	All	0.05	0.1	0.4	0.8	2.5
		2	15~100		0.05	0.1	0.3	0.4	0.8
Backlash ⁽³⁾	arcmin	1	3~10	All	≤ 8	≤ 7	≤ 6	≤ 6	≤ 6
		2	15~100	All	≤ 10	≤ 9	≤ 8	≤ 8	≤ 8
Torsional Rigidity ⁽⁵⁾	Nm/arcmin	1,2	3~100	PSII	0.6	1.5	6	10.5	18
				PEII	0.9	2.2	8	12	16
				PAII	0.9	2.2	8	12	16
				PGII	0.5	2	8	12	16
Nominal Input Speed n_{1N}	rpm	1,2	3~100	All	4,500	4,000	3,600	3,600	2,500
Max. Input Speed n_{1B}	rpm	1,2	3~100	All	8,000	6,000	6,000	4,800	3,600
Max. Radial Load F_{2rB} ⁽⁴⁾	N	1,2	3~100	PSII	840	1,290	1,510	3,780	5,420
				PEII	810	1,150	1,530	3,260	4,550
				PAII	810	1,150	1,530	3,470	4,640
				PGII	520	1,030	1,570	3,590	4,690
Max. Axial Load F_{2aB} ⁽⁴⁾	N	1,2	3~100	PSII	420	645	755	1,890	2,710
				PEII	405	575	765	1,630	2,275
				PAII	405	575	765	1,735	2,320
				PGII	260	515	785	1,795	2,345
Service Life ⁽⁶⁾	hr	1,2	3~100	All	20,000				
Operating Temp	°C	1,2	3~100	All	0° C ~ +90° C				
Degree of Gearbox Protection		1,2	3~100	All	IP65				
Lubrication		1,2	3~100	All	Synthetic lubrication grease				
Mounting Position		1,2	3~100	All	All directions				
Running Noise ⁽⁵⁾	dB(A)	1,2		All	≤ 60	≤ 62	≤ 64	≤ 66	≤ 68
Efficiency η	%	1	3~10	All	≥ 97%				
		2	15~100		≥ 94%				

(1) Ratio ($i = N_{in} / N_{out}$).

(2) Ratio 9 and 81 are only provided for PSII and PAII series.

(3) Backlash is measured at 2% of Nominal Output Torque T_{2N} .

(4) Applied to the output shaft center at 100 rpm.

(5) These values are measured by gearbox with ratio = 10 (1-stage) or ratio = 100 (2-stage) at 3,000 rpm without load.

Under other conditions, this data will be different.

(6) For continuous operation, the service life time is less than 10,000 hrs.

© 2014 by APEX DYNAMICS, INC.

APEX DYNAMICS, INC. reserves modification and copy right of all technical specifications, illustrations and drawings in this catalog in allowance for continuous products development and advancement.

For the newest data and information, please visit www.apexdyna.com/

PII Gearbox Inertia

Model No.		PSII A		PSII B		PSII C		PSII D		PSII E	
		PEII 050		PEII 070		PEII 090		PEII 120		PEII 155	
		PAII 042		PAII 060		PAII 090		PAII 115		PAII 142	
		PGII 040		PGII 060		PGII 080		PGII 120		PGII 160	
$\emptyset^{(A)}$ (c3)		1-stage	2-stage	1-stage	2-stage	1-stage	2-stage	1-stage	2-stage	1-stage	2-stage
8	kg.cm ²	0.10	0.10	0.10~ 0.12	0.10	-	-	-	-	-	-
11		0.16	0.16	0.16~ 0.19	0.16	-	-	-	-	-	-
14		0.19~ 0.20	0.19~ 0.20	0.20~ 0.22	0.20	0.20~ 0.36	0.20~ 0.24	-	-	-	-
19		-	-	1.51~ 1.53	1.51	1.54~ 1.70	1.54~ 1.58	1.60~ 2.20	1.60~ 1.73	-	1.69~ 2.18
24		-	-	-	-	2.09~ 2.24	2.09~ 2.12	2.14~ 2.74	2.14~ 2.27	2.23~ 4.52	2.23~ 2.73
28		-	-	-	-	2.52~ 2.68	2.52~ 2.55	2.57~ 3.17	2.57~ 2.70	2.65~ 4.94	2.65~ 3.15
32		-	-	-	-	-	-	7.17~ 7.77	7.17~ 7.30	7.41~ 9.70	7.41~ 7.91
35		-	-	-	-	-	-	10.20~ 10.80	10.20~ 10.30	10.50~ 12.80	10.50~ 11.00
38		-	-	-	-	-	-	13.40~ 14.00	13.40~ 13.50	13.70~ 16.00	13.70~ 14.20
42		-	-	-	-	-	-	-	-	22.20~ 24.50	-

(A) \emptyset = Input shaft diameter.

PSII Series Dimension

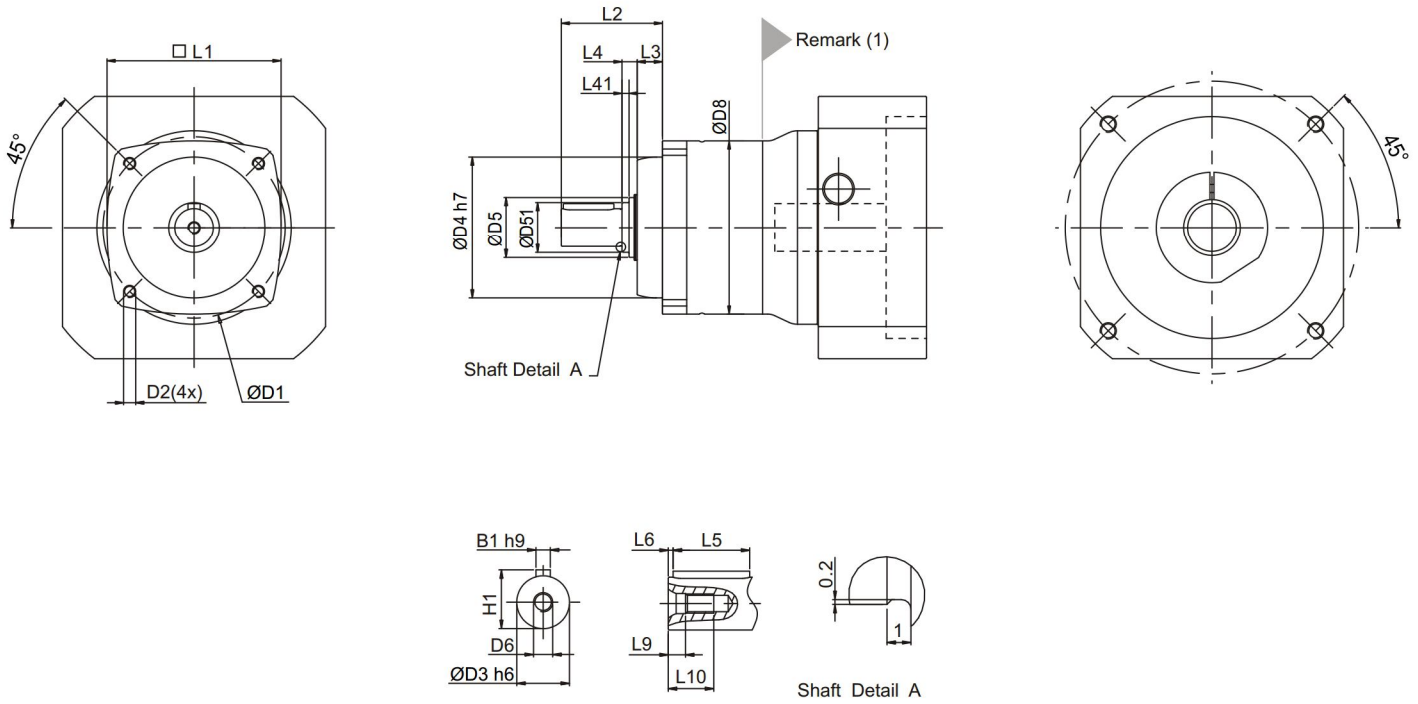

Dimension	PSII A		PSII B		PSII C		PSII D		PSII E	
	1-stage	2-stage	1-stage	2-stage	1-stage	2-stage	1-stage	2-stage	1-stage	2-stage
D1	47		60		90		115		135	
D2	M4X9		M5X10		M6X12		M8X18.5		M10X18	
D3	h6	10	12	19	24	32				
D4	h7	38	50	70	90	110				
D5		17	22	30	40	55				
D51		-	-	25	-	-				
D6	M3X0.5P		M4X0.7P		M6X1P		M8X1.25P		M12X1.75P	
D8	44		60		86		114		140	
L1	44		60		86		114		140	
L2	25		32		50		61		75	
L3	6.5		8.5		12.5		16		14.5	
L4	2.5		3.5		7.5		5		5.5	
L41	-		-		3.5		-		-	
L5	10		16		25		32		50	
L6	3		2		1		3		2	
L9	2.6		4.5		5		7.2		10	
L10	9		10		16.5		19		28	
B1	h9	3	4	6	8	10				
H1		11.2	13.5	21.5	27	35				

(1) Dimensions are related to motor interface. Please contact APEX for details.

PEII Series Dimension

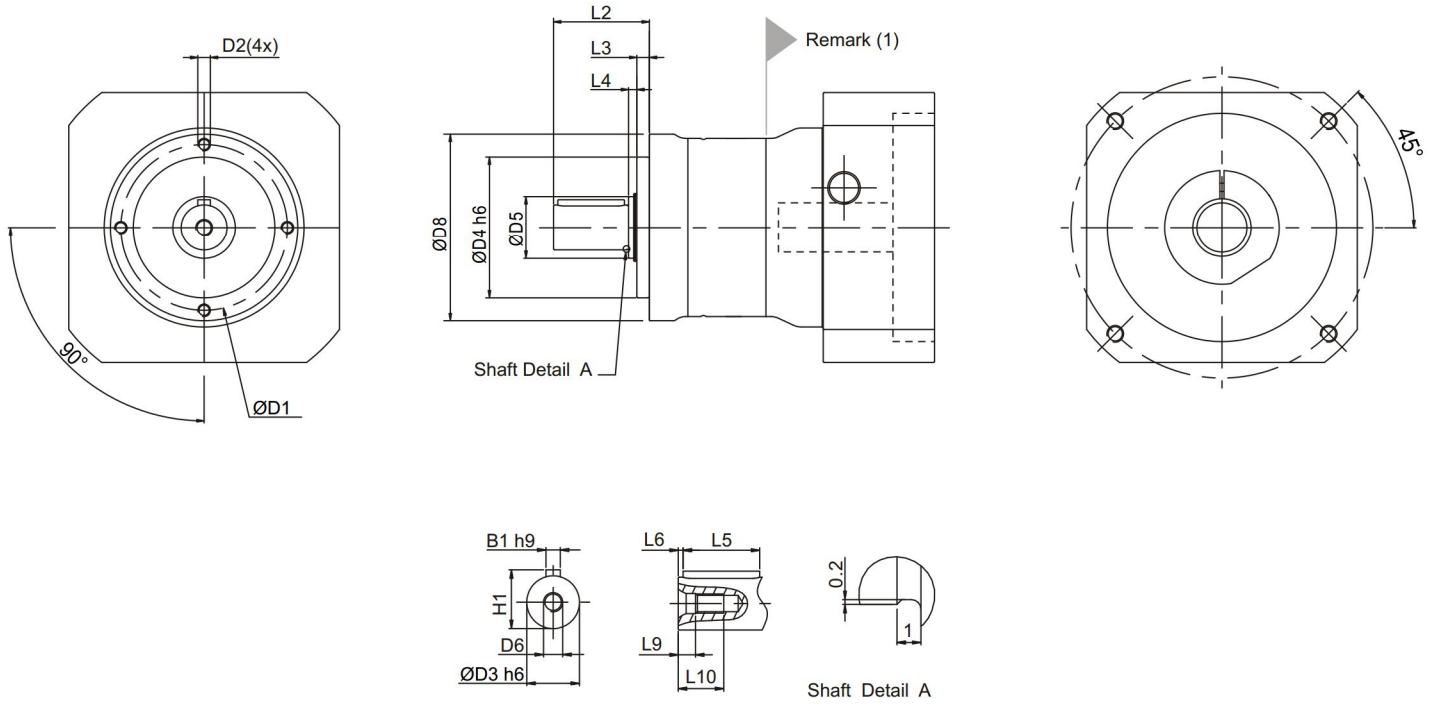

Dimension	PEII 050		PEII 070		PEII 090		PEII 120		PEII 155	
	1-stage	2-stage	1-stage	2-stage	1-stage	2-stage	1-stage	2-stage	1-stage	2-stage
D1	44		62		80		108		140	
D2	M4X9		M5X10		M6X12		M8X15		M10X18	
D3	h6	12	16	22	32	40				
D4	h6	35	52	68	90	120				
D5		17	22	30	40	55				
D6		M4X0.7P	M5X0.8P	M8X1.25P	M12X1.75P	M16X2P				
D8		50	70	90	120	155				
L2		24.5	36	46	70	97				
L3		4	4.5	6	7	9.5				
L4		2.5	3.5	4	5	5.5				
L5		14	25	32	50	70				
L6		2	2	2	4	6				
L9		4.5	4.8	7.2	10	12				
L10		10	12.5	19	28	36				
B1	h9	4	5	6	10	12				
H1		13.5	18	24.5	35	43				

(1) Dimensions are related to motor interface. Please contact APEX for details.

PAII Series Dimension

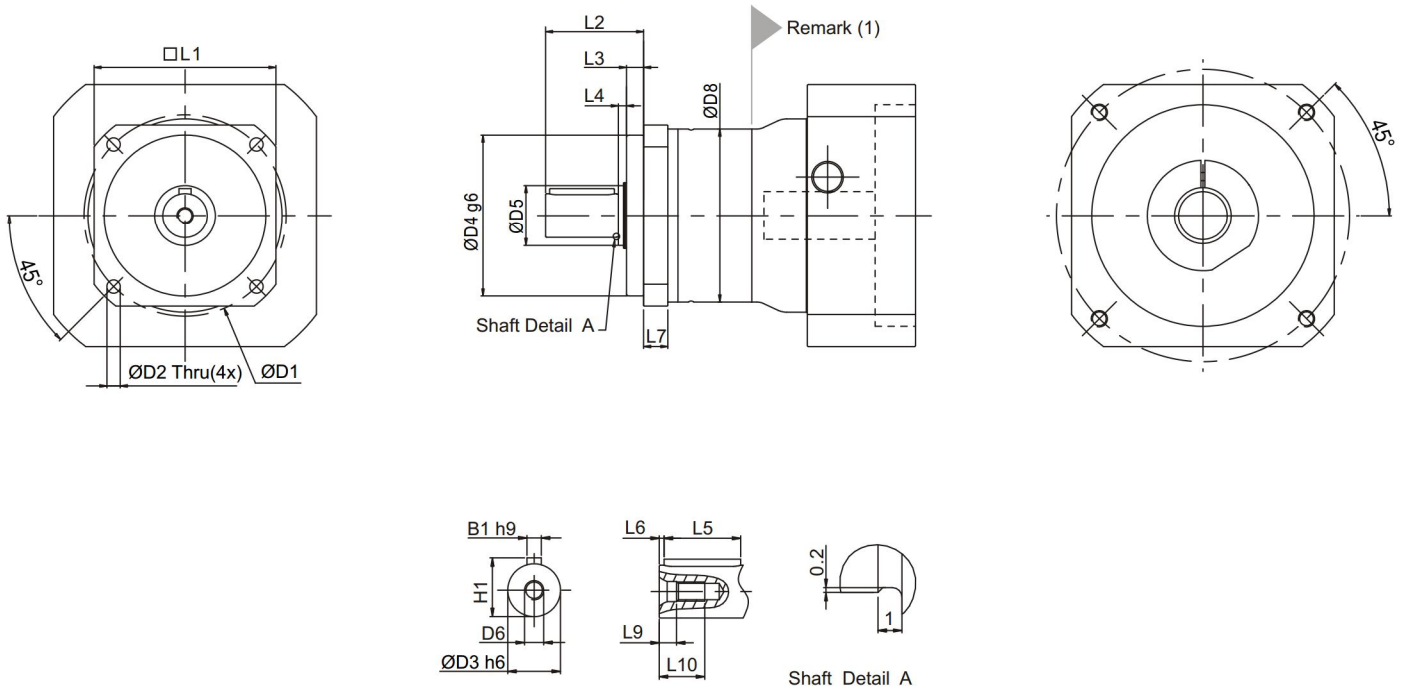

Dimension	PAII 042		PAII 060		PAII 090		PAII 115		PAII 142	
	1-stage	2-stage	1-stage	2-stage	1-stage	2-stage	1-stage	2-stage	1-stage	2-stage
D1	50		70		100		130		165	
D2	3.4		5.5		6.6		9		11	
D3	h6		13		16		22		32	
D4	g6		35		50		80		110	
D5			17		22		30		40	
D6			M4X0.7P		M5X0.8P		M8X1.25P		M12X1.75P	
D8			44		60		86		114	
L1			42		60		90		115	
L2			26		37		48.5		65	
L3			5.5		5.5		8.5		10	
L4			2.5		3.5		4		5	
L5			14		25		32		40	
L6			2		2		2		5	
L7			6.5		10		12		16	
L9			4.5		4.8		7.2		10	
L10			10		12.5		19		28	
B1	h9		5		5		6		10	
H1			15		18		24.5		35	

(1) Dimensions are related to motor interface. Please contact APEX for details.

PGII Series Dimension

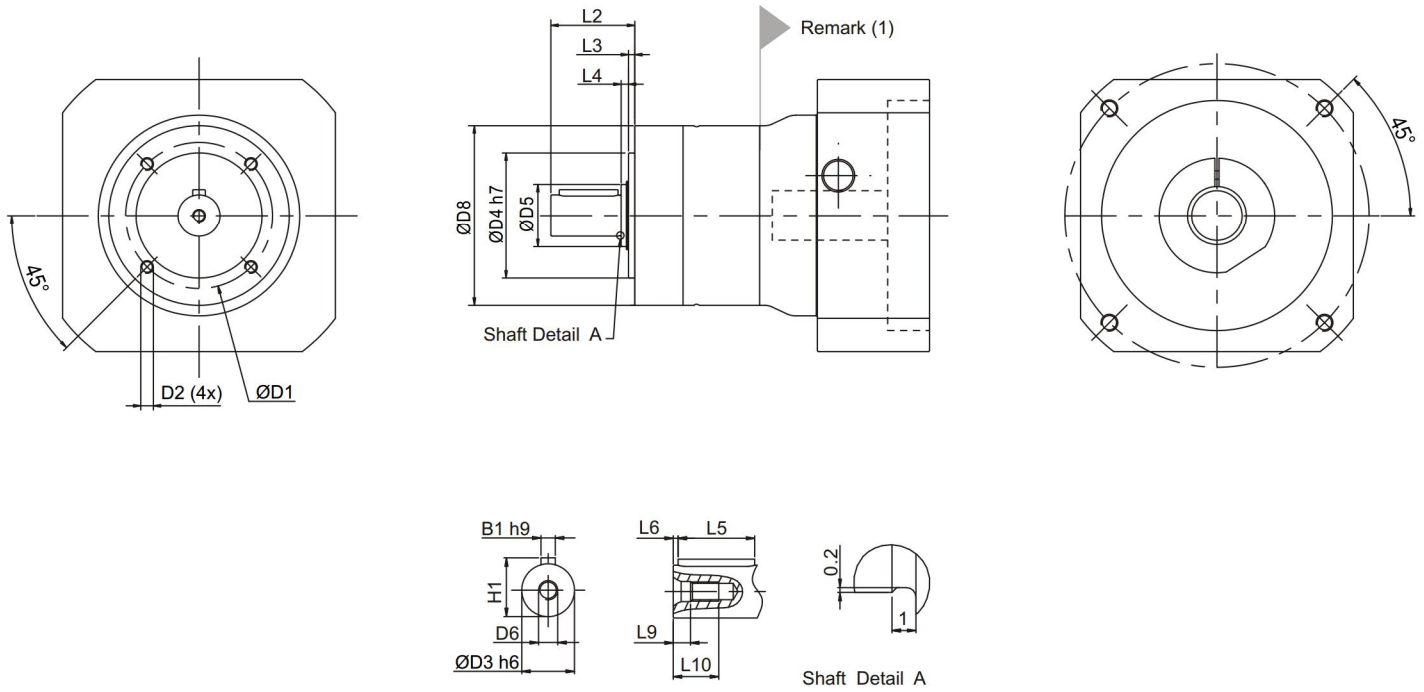

Dimension	PGII 040		PGII 060		PGII 080		PGII 120		PGII 160	
	1-stage	2-stage	1-stage	2-stage	1-stage	2-stage	1-stage	2-stage	1-stage	2-stage
D1	34		52		70		100		145	
D2	M4X9		M5X10		M6X12		M10X18		M12X22	
D3	h6	10	14	20	25	40	40	55	130	160
D4	h7	26	40	60	80	114	160	22.5	36	43
D5		17	17	30	40	55	87	5	5.5	65
D6		M3X0.5P	M5X0.8P	M6X1P	M10X1.5P	M16X2P				
D8		44	60	86	114	160				
L2		26	35	40	55	87				
L3		2	3	3	4	5				
L4		1	2	3.5	5	5.5				
L5		18	25	28	40	65				
L6		2.5	2.5	4	5	8				
L9		2.6	4.8	5	7.5	12				
L10		9	12.5	16.5	22	36				
B1	h9	3	5	6	8	12				
H1		11.2	16	22.5	28	43				

(1) Dimensions are related to motor interface. Please contact APEX for details.

PIIR Gearbox Performance

Model No.		Stages	Ratio ⁽¹⁾	Type	PSIIR A	PSIIR B	PSIIR C	PSIIR D	PSIIR E
					PEIIR 050	PEIIR 070	PEIIR 090	PEIIR 120	PEIIR 155
					PAIIR 042	PAIIR 060	PAIIR 090	PAIIR 115	PAIIR 142
					PGIIR 040	PGIIR 060	PGIIR 080	PGIIR 120	PGIIR 160
Nominal Output Torque T_{2N}	Nm	1	3	All	16	42	110	217	430
			4		16	42	113	223	440
			5		15	40	118	220	435
			7		12	35	96	198	366
			9 ⁽²⁾		8	24	60	125	273
			10		10	27	68	155	295
		2	15		15	40	109	213	424
			16		16	42	116	228	452
			20		16	42	116	230	454
			25		15	40	123	228	450
			30		15	40	108	212	422
			35		12	35	100	206	382
			40		16	43	117	232	459
			50		15	40	123	228	450
			70		12	35	100	206	382
			81 ⁽²⁾		8	24	59	131	285
			100		10	27	70	162	308
			Emergency Stop Torque T_{2NOT}		Nm	1,2	3~100	All	3 times T_{2N}
Max. Acceleration Torque T_{2B}	Nm	1,2	3~100	All	$T_{2B} = 60\%$ of T_{2NOT}				
No Load Running Torque ⁽⁵⁾	Nm	1	3~10	All	0.1	0.15	0.45	0.85	2.55
		2	15~100		0.1	0.15	0.35	0.45	0.85
Backlash ⁽³⁾	arcmin	1	3~10	All	≤ 12	≤ 11	≤ 10	≤ 10	≤ 10
		2	15~100	All	≤ 14	≤ 13	≤ 12	≤ 12	≤ 12
Torsional Rigidity ⁽⁵⁾	Nm/arcmin	1,2	3~100	PSIIR	0.6	1.5	6	10.5	18
				PEIIR	0.9	2.2	8	12	16
				PAIIR	0.9	2.2	8	12	16
				PGIIR	0.5	2	8	12	16
Nominal Input Speed n_{1N}	rpm	1,2	3~100	All	4,500	4,000	3,600	3,600	2,500
Max. Input Speed n_{1B}	rpm	1,2	3~100	All	8,000	6,000	6,000	4,800	3,600
Max. Radial Load F_{2rB} ⁽⁴⁾	N	1,2	3~100	PSIIR	840	1,290	1,510	3,780	5,420
				PEIIR	810	1,150	1,530	3,260	4,550
				PAIIR	810	1,150	1,530	3,470	4,640
				PGIIR	520	1,030	1,570	3,590	4,690
Max. Axial Load F_{2aB} ⁽⁴⁾	N	1,2	3~100	PSIIR	420	645	755	1,890	2,710
				PEIIR	405	575	765	1,630	2,275
				PAIIR	405	575	765	1,735	2,320
				PGIIR	260	515	785	1,795	2,345
Service Life ⁽⁶⁾	hr	1,2	3~100	All	20,000				
Operating Temp	°C	1,2	3~100	All	0° C ~ +90° C				
Degree of Gearbox Protection		1,2	3~100	All	IP65				
Lubrication		1,2	3~100	All	Synthetic lubrication grease				
Mounting Position		1,2	3~100	All	All directions				
Running Noise ⁽⁵⁾	dB(A)	1,2		All	≤ 70	≤ 72	≤ 74	≤ 75	≤ 77
Efficiency η	%	1	3~10	All	$\geq 93\%$				
		2	15~100		$\geq 90\%$				

(1) Ratio ($i = N_{in} / N_{out}$).

(2) Ratio 9 and 81 are only provided for PSII and PAII series.

(3) Backlash is measured at 2% of Nominal Output Torque T_{2N} .

(4) Applied to the output shaft center at 100 rpm.

(5) These values are measured by gearbox with ratio = 10 (1-stage) or ratio = 100 (2-stage) at 3,000 rpm without load.

Under other conditions, this data will be different.

(6) For continuous operation, the service life time is less than 10,000 hrs.

PIIR Gearbox Inertia

Model No.		PSIIR A		PSIIR B		PSIIR C		PSIIR D		PSIIR E	
		PEIIR 050		PEIIR 070		PEIIR 090		PEIIR 120		PEIIR 155	
		PAIIR 042		PAIIR 060		PAIIR 090		PAIIR 115		PAIIR 142	
		PGIIR 040		PGIIR 060		PGIIR 080		PGIIR 120		PGIIR 160	
$\emptyset^{(A)}$ (c3)		1-stage	2-stage	1-stage	2-stage	1-stage	2-stage	1-stage	2-stage	1-stage	2-stage
8	kg.cm ²	0.18	0.18	0.36	0.36	-	-	-	-	-	-
11		0.20	0.20	0.39	0.39	-	-	-	-	-	-
14		0.24	0.24	0.43	0.43	1.87	1.87	-	-	-	-
19		-	-	1.24	1.24	2.67	2.67	6.80	6.80	-	13.57
24		-	-	-	-	2.97	2.97	7.10	7.10	13.87	13.87
28		-	-	-	-	3.47	3.47	7.59	7.59	14.36	14.36
32		-	-	-	-	-	-	10.56	10.56	17.33	17.33
35		-	-	-	-	-	-	11.97	11.97	18.74	18.74
38		-	-	-	-	-	-	13.95	13.95	20.79	20.79
42		-	-	-	-	-	-	-	-	26.54	-

(A) \emptyset = Input shaft diameter.

PSIIR Series Dimension

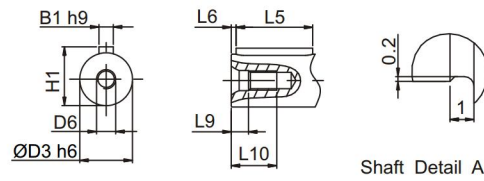
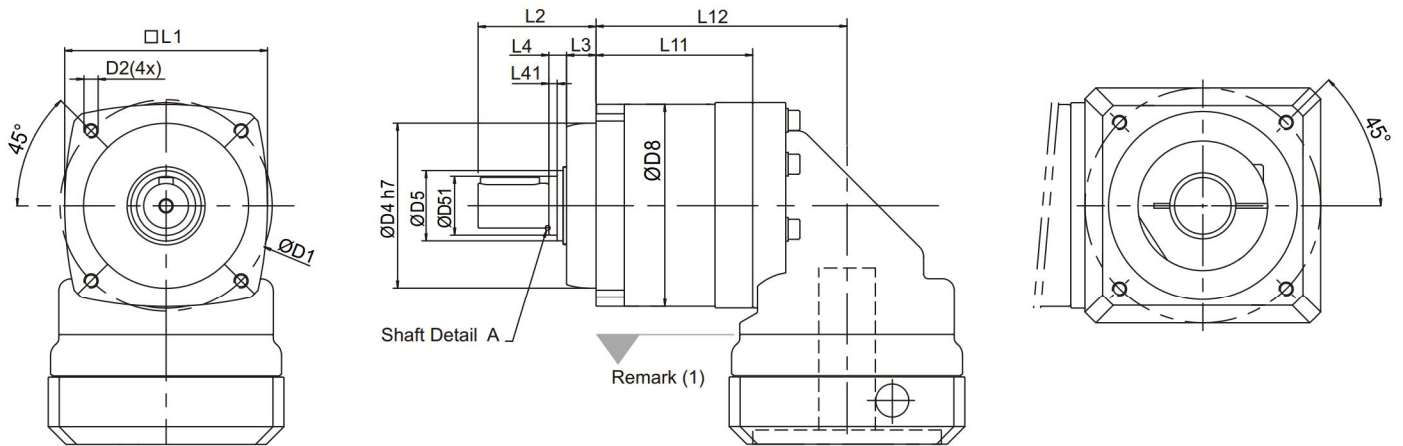

Dimension	PSIIR A		PSIIR B		PSIIR C		PSIIR D		PSIIR E	
	1-stage	2-stage	1-stage	2-stage	1-stage	2-stage	1-stage	2-stage	1-stage	2-stage
D1	47		60		90		115		135	
D2	M4X9		M5X10		M6X12		M8X18.5		M10X18	
D3	h6	10	12		19		24		32	
D4	h7	38	50		70		90		110	
D5		17	22		30		40		55	
D51		-	-		25		-		-	
D6		M3X0.5P	M4X0.7P		M6X1P		M8X1.25P		M12X1.75P	
D8		44	60		86		114		140	
L1		44	60		86		114		140	
L2		25	32		50		61		75	
L3		6.5	8.5		12.5		16		14.5	
L4		2.5	3.5		7.5		5		5.5	
L41		-	-		3.5		-		-	
L5		10	16		25		32		50	
L6		3	2		1		3		2	
L9		2.6	4.5		5		7.2		10	
L10		9	10		16.5		19		28	
L11	47	62	56	76	66.5	93	92	128	116	163.5
L12	72	87	85.5	105.5	106.5	133	143	179	173	220.5
B1	h9	3	4		6		8		10	
H1		11.2	13.5		21.5		27		35	

(1) Dimensions are related to motor interface. Please contact APEX for details.

PEIR Series Dimension

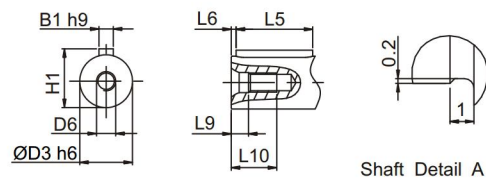
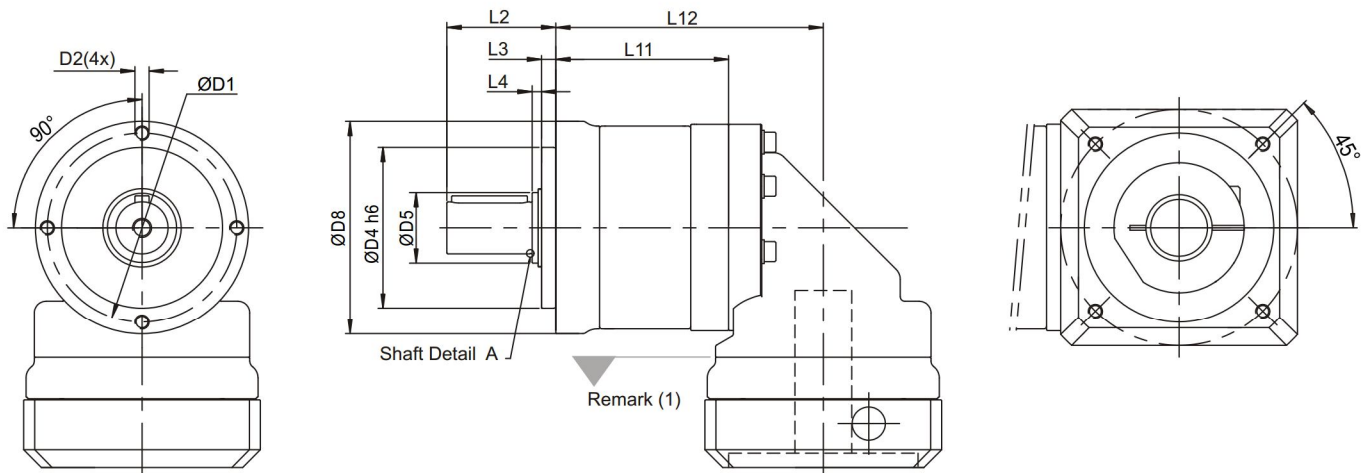

Dimension	PEIR 050		PEIR 070		PEIR 090		PEIR 120		PEIR 155	
	1-stage	2-stage	1-stage	2-stage	1-stage	2-stage	1-stage	2-stage	1-stage	2-stage
D1	44		62		80		108		140	
D2	M4X9		M5X10		M6X12		M8X15		M10X18	
D3	h6		12		16		22		32	
D4	h6		35		52		68		90	
D5			17		22		30		40	
D6			M4X0.7P		M5X0.8P		M8X1.25P		M12X1.75P	
D8			50		70		90		120	
L2			24.5		36		46		70	
L3			4		4.5		6		7	
L4			2.5		3.5		4		5	
L5			14		25		32		50	
L6			2		2		2		4	
L9			4.5		4.8		7.2		10	
L10			10		12.5		19		28	
L11	49.5	64.5	60	80	73	99.5	101	137	121	168.5
L12	74.5	89.5	89.5	109.5	113	139.5	152	188	178	225.5
B1	h9		4		5		6		10	
H1			13.5		18		24.5		35	

(1) Dimensions are related to motor interface. Please contact APEX for details.

PAIIR Series Dimension

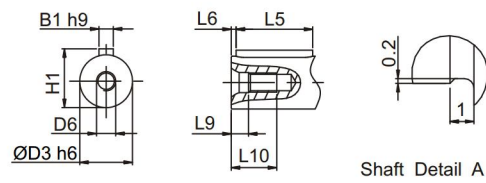
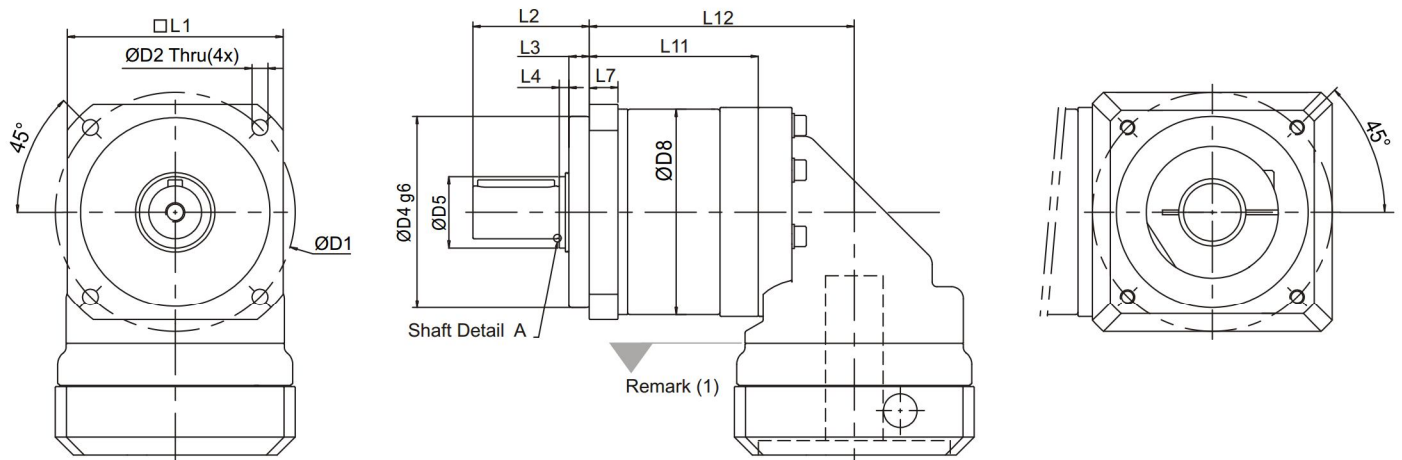

Dimension	PAIIR 042		PAIIR 060		PAIIR 090		PAIIR 115		PAIIR 142	
	1-stage	2-stage	1-stage	2-stage	1-stage	2-stage	1-stage	2-stage	1-stage	2-stage
D1	50		70		100		130		165	
D2	3.4		5.5		6.6		9		11	
D3 h6	13		16		22		32		40	
D4 g6	35		50		80		110		130	
D5	17		22		30		40		55	
D6	M4X0.7P		M5X0.8P		M8X1.25P		M12X1.75P		M16X2P	
D8	44		60		86		114		140	
L1	42		60		90		115		142	
L2	26		37		48.5		65		97	
L3	5.5		5.5		8.5		10		12.5	
L4	2.5		3.5		4		5		5.5	
L5	14		25		32		40		63	
L6	2		2		2		5		5	
L7	6.5		10		12		16		20	
L9	4.5		4.8		7.2		10		12	
L10	10		12.5		19		28		36	
L11	48	63	59	79	70.5	97	98	134	118	165.5
L12	73	88	88.5	108.5	110.5	137	149	185	175	222.5
B1 h9	5		5		6		10		12	
H1	15		18		24.5		35		43	

(1) Dimensions are related to motor interface. Please contact APEX for details.

PGIIR Series Dimension

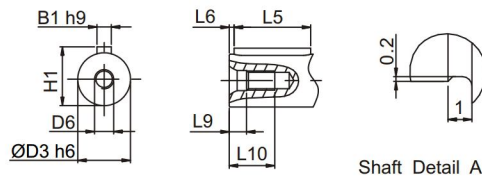
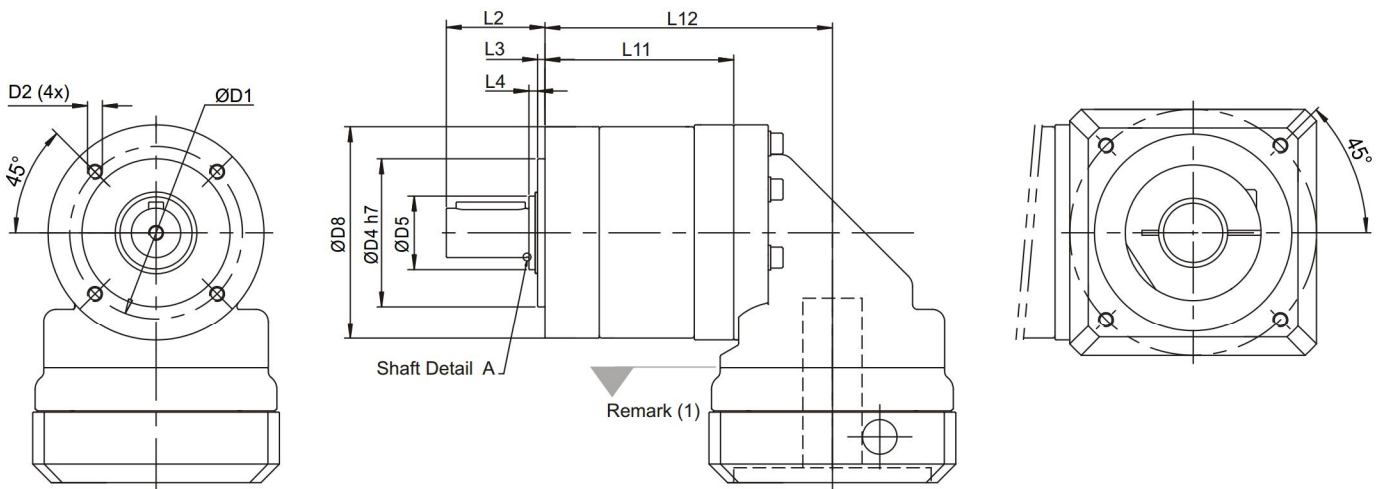

Dimension	PGIIR 040		PGIIR 060		PGIIR 080		PGIIR 120		PGIIR 160	
	1-stage	2-stage	1-stage	2-stage	1-stage	2-stage	1-stage	2-stage	1-stage	2-stage
D1	34		52		70		100		145	
D2	M4X9		M5X10		M6X12		M10X18		M12X22	
D3	h6	10	14	20	25	40	55	60	86	114
D4	h7	26	40	60	80	130	170	220	340	440
D5		17	17	30	40	55	86	114	170	220
D6		M3X0.5P	M5X0.8P	M6X1P	M10X1.5P	M16X2P	M20X2.5P	M25X3P	M40X4P	M50X5P
D8		44	60	86	114	170	220	340	440	550
L2		26	35	40	55	87	114	170	220	340
L3		2	3	3	4	5	7.5	12	17	22
L4		1	2	3.5	5	5.5	7.5	12	17	22
L5		18	25	28	40	65	86	114	170	220
L6		2.5	2.5	4	5	8	12	17	22	36
L9		2.6	4.8	5	7.5	12	17	22	36	43
L10		9	12.5	16.5	22	36	43	55	68	87
L11		53	68	76.5	103	125.5	173	220	280	340
L12		78	93	116.5	143	182.5	230	280	340	440
B1	h9	3	5	6	8	12	17	22	36	43
H1		11.2	16	22.5	28	43	55	68	87	114

(1) Dimensions are related to motor interface. Please contact APEX for details.

Selection of the optimum gearbox

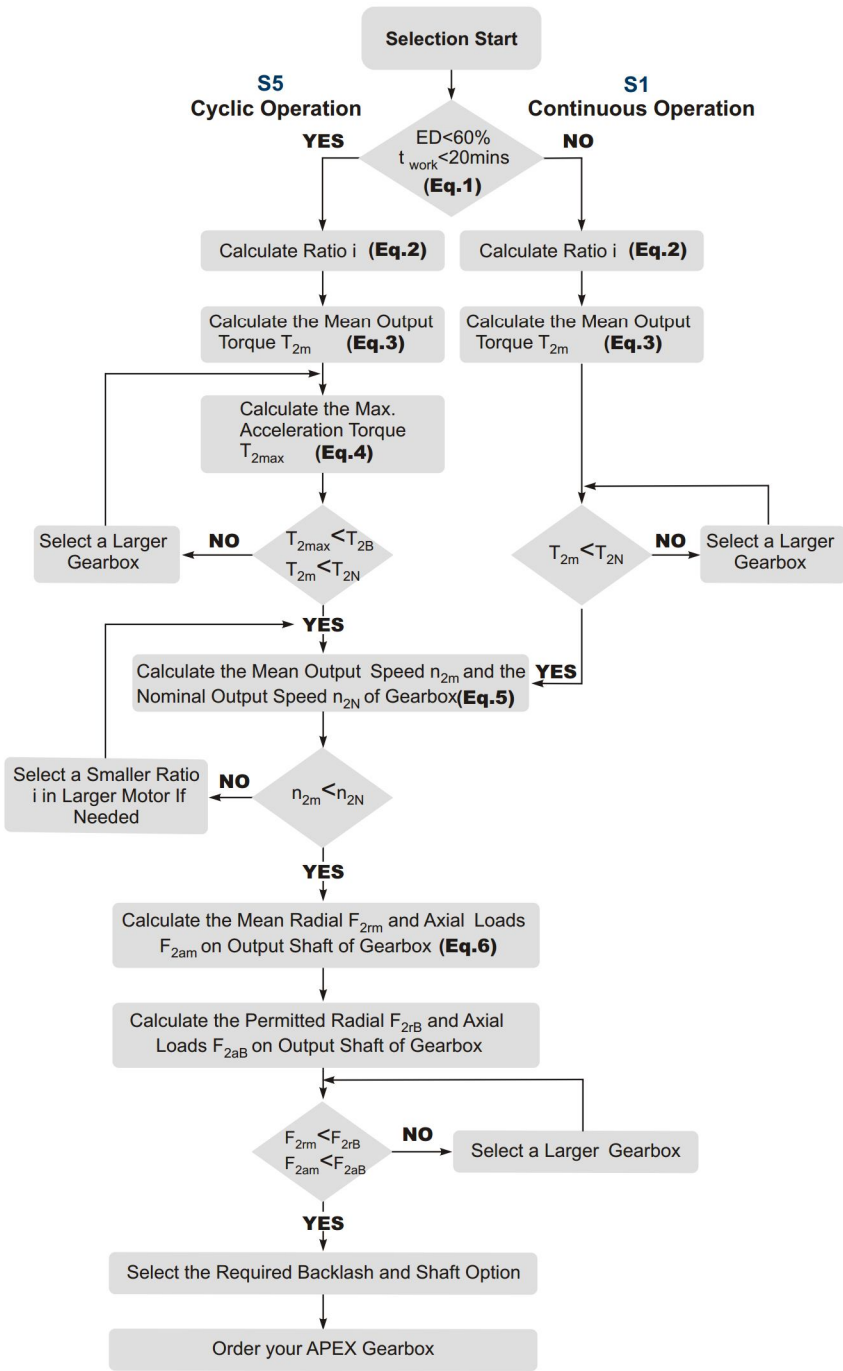

Recommended (for S5 Cycle Operation)

The general design is given for

$$\frac{J_L}{i^2} \leq 4 \times J_m$$

The optimal design is given for

$$\frac{J_L}{i^2} \cong J_m$$

J_L Load Inertia

J_m Motor Inertia

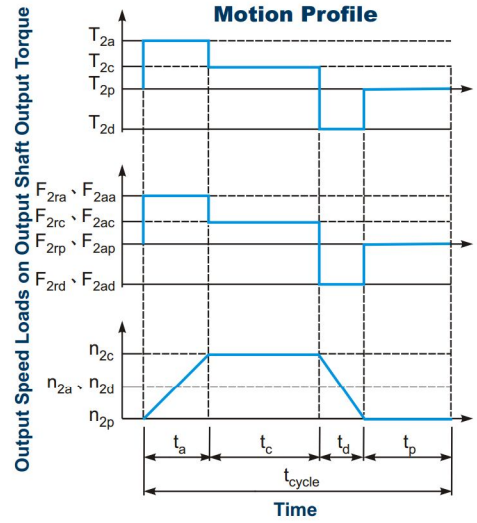

1. $ED = \frac{t_a + t_c + t_d}{t_{cycle}} \times 100\%$, $t_{work} = t_a + t_c + t_d$
 Index : a. Acceleration, c. Constant, d. Deceleration, p. Pause (Eq.1)

2. $i \cong \frac{n_m}{n_{work}}$
 n_m Output Speed of the Motor
 n_{work} Working Speed (Eq.2)

3. $T_{2m} = 3 \sqrt{\frac{n_{2a} \times t_a \times T_{2a}^3 + n_{2c} \times t_c \times T_{2c}^3 + n_{2d} \times t_d \times T_{2d}^3}{n_{2a} \times t_a + n_{2c} \times t_c + n_{2d} \times t_d}}$ (Eq.3)

4. $T_{2max} = T_{mB} \times i \times K_s \times \eta$
 where K_s is

K_s	No. of Cycles / hr
1.0	0 ~ 1,000
1.1	1,000 ~ 1,500
1.3	1,500 ~ 2,000
1.6	2,000 ~ 3,000
1.8	3,000 ~ 5,000

T_{mB} Max. Output Torque of the Motor
 η Efficiency of the Gearbox (Eq.4)

5. $n_{2a} = n_{2d} = \frac{1}{2} \times n_{2c}$
 $n_{2m} = \frac{n_{2a} \times t_a + n_{2c} \times t_c + n_{2d} \times t_d}{t_a + t_c + t_d}$
 $n_{2N} = \frac{n_{1N}}{i}$ (Eq.5)

6. $F_{2rm} = 3 \sqrt{\frac{n_{2a} \times t_a \times F_{2ra}^3 + n_{2c} \times t_c \times F_{2rc}^3 + n_{2d} \times t_d \times F_{2rd}^3}{n_{2a} \times t_a + n_{2c} \times t_c + n_{2d} \times t_d}}$
 $F_{2am} = 3 \sqrt{\frac{n_{2a} \times t_a \times F_{2aa}^3 + n_{2c} \times t_c \times F_{2ac}^3 + n_{2d} \times t_d \times F_{2ad}^3}{n_{2a} \times t_a + n_{2c} \times t_c + n_{2d} \times t_d}}$ (Eq.6)

Glossary

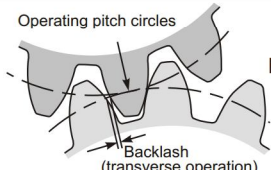
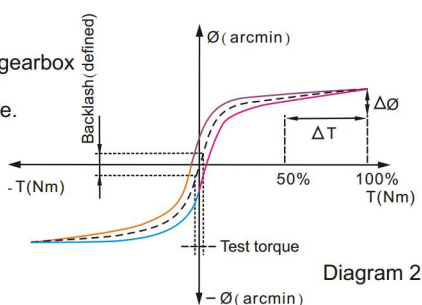
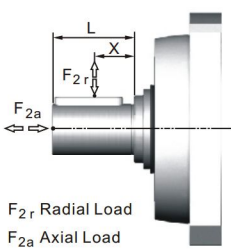
Emergency Stop Torque T_{2NOT}	Nm	The Emergency Stop Torque is the maximum permitted torque at the output of gearbox. This may happen only occasionally and may not exceed 1,000 times during the whole service life.
Max. Acceleration Torque T_{2B}	Nm	Under the Cyclic Operation (S5), the Max. Acceleration Torque is the maximum torque which can be transmitted only briefly to the output of gearbox up to 1,000 cycles/hr.
No Load Running Torque	Nm	The No Load Running Torque is the min. torque to overcome the internal friction of a gearbox without loading*.
Nominal Input Speed n_{1N}	rpm	The Nominal Input Speed is the permitted input speed of gearbox by the Continuous Operation (S1) while the housing temperature does not exceed 90°C. This value is measured at environment temperature 25°C.
Max. Input Speed n_{1B}	rpm	The Max. Input Speed is the max. permitted input speed of gearbox by the Cyclic operation (S5). This value is measured at environment temperature 25°C and serves as the absolute limit of the gearbox.
Backlash	arcmin	<p>The Backlash is the maximum angular measurement between two teeth of gears when the transverse operation occurs (refer to Diagram 1). The arcmin is the measurement unit for the backlash. One arcmin equals 1/60 degree, symbolized as 1'.</p>  <p style="text-align: right;">Diagram 1</p>
Torsional Rigidity	Nm/arcmin	<p>Torsional Rigidity is the quotient ($\Delta T / \Delta \theta$) between the applied torque and resulting torsion angle. This value indicates how much torque is needed on the gearbox to rotate the output shaft for 1 arcmin. The Torsional Rigidity can be determined by Hysteresis Curve.</p> <p>Hysteresis Curve When the input shaft is locked, increase torque at the output slowly up to T_{2B} in both directions and then release the torque gradually. According to the measured torque and torsion angle, a closed curve will be acquired as in the Diagram 2.</p>  <p style="text-align: right;">Diagram 2</p>
Radial Load And Axial Load	N	<p>The permitted radial and axial loads on output shaft of the gearbox depend on the design of the gearbox supporting bearings.</p> <p>For more information, please refer to APEX website.</p>  <p style="text-align: right;">F_{2r} Radial Load F_{2a} Axial Load</p>
Efficiency η	%	The transmission efficiency of the gears inside a gearbox (without friction).
Operating Temperature	°C	The Operating Temperature indicates the temperature of gearbox housing.
Degree of Protection		IP code stands for International Protection standard. The IP65 as example: the first IP number stands for protection degree against dust; the second IP number stands for protection against liquid.
Lubrication		APEX uses synthetic lubrication grease. Alternate greases are available, please contact APEX.
Running Noise	dB(A)	The Running Noise is measured depends on gearbox size, the ratio and the speed*. Higher speed usually induces higher noise level, while higher ratio induces lower noise level.
Moment of Inertia J_1	kg.cm ²	The Moment of Inertia J_1 is a measurement of the effort applied to an object to maintain its momentary condition at rest or rotating.
Breakaway Torque	Nm	The Breakaway Torque is the minimum torque to start the rotation from the input side of gearbox. A smaller size or a higher ratio gearbox requests less Breakaway Torque.
Back Driving Torque	Nm	The Back Driving Torque is the minimum torque to start the rotation from the output side of gearbox. A larger size or a higher ratio gearbox requires greater Back Driving Torque.

* This value is measured at environment temperature 25°C and the input speed 3,000 rpm. If the Nominal Input Speed n_{1N} of gearbox is over 3,000 rpm, this value is measured by that specific Nominal Input Speed.



APEX DYNAMICS, INC.

No. 10, Keyuan 3rd Road, Situn District, Taichung City 407, Taiwan R.O.C

TEL: 886-4-24650219 / FAX: 886-4-24650118

E-Mail: sales@apexdyna.com Website: <http://www.apexdyna.com/>

APEX-2014-12-PII/PIIR SERIES-1.0E-1.0V

