

**Best choice for greatest benefit!**

LS Mecapion always tries its best to bring the greatest benefit to its customers.

# AC Servo User Manual

**L7N Series**

V1.7

**EtherCAT**<sup>®</sup>  
Conformance tested



## **Safety Precautions**

- Be sure to read the safety precautions before use and use the product accordingly.
- After reading this user manual, keep it in a place where users can always see it.

**LS** Mecapion

# Introduction

Hello. Thank you for choosing the LS Mecapion L7N Series AC Servo.



This user manual describes how to use this product safely and efficiently.

Failure to comply with the guidelines outlined in this manual may cause personal injury or damage to the product. Be sure to read this manual carefully before using this product and follow all guidelines contained therein.

- The contents of this manual are subject to change without notice.
- The reproduction of part or all of the contents of this manual in any form, by any means or for any purpose is strictly prohibited without the explicit written consent of LS Mecapion.
- LS Mecapion retains all patents, trademarks, copyrights and other intellectual property rights to the material in this manual. The information contained in this manual is only intended for use with LS Mecapion products.
- EtherCAT® is registered trademark and patented technology, licensed by Beckhoff Automation, GmbH, Germany.

# Safety Precautions

Safety precautions are categorized as either Warnings or Cautions, depending on the severity of the precaution.

Precautions	Definition
 <b>Warnings</b>	Failure to comply with these guidelines may cause serious injury or death.
 <b>Caution</b>	Failure to comply with these guidelines may cause personal injury or property damage.

- Precautions listed as Cautions may also result in serious injury.

## ■ Electric Safety Precautions

 <b>Warning</b>
<ul style="list-style-type: none"> <li>▪ Before wiring or inspecting the device, turn off the power, wait 15 minutes, ensure that the charge lamp is off, and then check the voltage.</li> <li>▪ Ground both the servo drive and the servo motor.</li> <li>▪ Only specially trained technicians may perform wiring on this product.</li> <li>▪ Install both the servo drive and servo motor before performing any wiring.</li> <li>▪ Do not operate the device with wet hands.</li> <li>▪ Do not open the servo drive cover during operation.</li> <li>▪ Do not operate the device with the servo drive cover removed.</li> <li>▪ Even if the power is off, do not remove the servo drive cover.</li> </ul>

## ■ Fire Safety Precautions

 <b>Caution</b>
<ul style="list-style-type: none"> <li>▪ Install the servo drive, the servo motor, and the regenerative resistor on non-combustible materials.</li> <li>▪ Disconnect the input power if the servo drive malfunctions.</li> </ul>

## ■ Installation Precautions

Store and operate this product under the following environmental conditions.

Environment	Conditions	
	The Servo Drive	The Servo Motor
Operating temp.	0 ~ 50 °C	0 ~ 40 °C
Storage temp.	-20 ~ 65 °C	-20 ~ 60 °C
Operating humidity	Below 90% RH (no condensation)	Below 80% RH
Storage humidity		Below 90% RH
Altitude	1000m or less	
Spacing	<ul style="list-style-type: none"> <li>▪ When installing 1 unit:                             <ul style="list-style-type: none"> <li>• More than 40 mm at the top and bottom of the control panel</li> <li>• More than 10 mm on the left and right sides of the control panel</li> </ul> </li> <li>▪ When installing 2 or more units:                             <ul style="list-style-type: none"> <li>• More than 100 mm at the top of the control panel</li> <li>• More than 40 mm at the bottom of the control panel</li> <li>• More than 30 mm on the left and right sides of the control panel</li> <li>• More than 2 mm between units</li> <li>• Refer to Section 2.2.2, "Wiring the Control Panel."</li> </ul> </li> </ul>	
Other variables	<ul style="list-style-type: none"> <li>▪ Ensure the installation location is free from dust, iron, corrosive gas, and combustible gas.</li> <li>▪ Ensure the installation location is free from vibrations or the potential for hard impacts.</li> </ul>	

### ⚠ Caution

- Install the product with the correct orientation.
- Do not drop the product or expose it to hard impact.
- Install this product in a location that is free from water, corrosive gas, combustible gas, or flammable materials.
- Install this product in a location capable of supporting the weight of this product.
- Do not stand on the product or place heavy objects on top of it.
- Always maintain the specified spacing when installing the servo drive.
- Ensure that there are no conductive or flammable debris inside the servo drive or the servo motor.
- Firmly attach the servo motor to the machine.
- Install the servo motor with a correctly oriented decelerator.
- Do not touch the rotating unit of the servo motor during operation.
- Do not apply excessive force when connecting the couplings to the servo motor shaft.
- Do not place loads on the servo motor shaft that exceed the specified amount.

## ■ Wiring Precautions

### ⚠ Caution

- Always use an AC 200-230 V power input for the servo drive.
- Always connect the servo drive to a ground terminal.
- Do not connect commercial power directly to the servo motor.
- Do not connect commercial power directly to the U, V, W output terminals of the servo drive.
- Connect the U, V, W output terminals of the servo drive directly to the U, V, W input terminals of the servo motor, but do not install magnetic contactors between the wires.
- Always use pressurized terminals with insulation tubes when connecting the servo drive power terminal.
- Always separate the U, V, and W cables for the servo motor power and encoder cable during wiring.
- Always use the robot cable if the motor moves.
- Before performing power line wiring, turn off the input power to the servo drive, and then wait until the CHARGE lamp turns off.

## ■ Startup Precautions

### ⚠ Caution

- Check the input voltage (AC 200-230 V) and power unit wiring before supplying power to the device.
- The servo must be off before you turn on the power.

## ■ Handling and Operating Precautions

### ⚠ Caution

- Check and adjust each parameter before operation.
- Do not touch the rotating unit of the motor during operation.
- Do not touch the heat sink during operation.

## ■ Usage Precautions

### ⚠ Caution

- Install an emergency cut-off switch which immediately stops operation in an emergency.
- Reset the alarm when the servo is off. The system immediately restarts if the alarm is reset while the servo is ON.
- Use a noise filter or DC reactor to minimize electromagnetic interference. This prevents nearby electrical devices from malfunctioning due to interference.
- Only use approved servo drive and servo motor combinations.
- The electric brake on the servo motor stops operation. Do not use it for ordinary braking.
- The electric brake may malfunction if the brake degrades or if the mechanical structure is improper (for example, if the ball screw and servo motor are combined via the timing belt). Install an emergency stop device to ensure mechanical safety.

## ■ Malfunction Precautions

### ⚠ Caution

- Install a servo motor with an electric brake or separate the brake system for use during emergencies or device malfunctions.
- If an alarm occurs, solve the underlying cause of the problem. After solving the problem and ensuring safe operation, deactivate the alarm and resume operation.
- Do not approach the machine until the problem is solved.

## ■ Repair/Inspection Precautions

### ⚠ Caution

- Before wiring or inspecting the device, turn off the power, wait 15 minutes, ensure that the CHARGE lamp is off, and then check the voltage. Enough voltage may remain in the condenser after the power is off to cause an electric shock.
- Only authorized personnel may repair and inspect the device or replace its parts.
- Do not modify this device in any way.

## ■ General Precautions

### ⚠ Caution

- This user manual is subject to change due to product modification or changes in standards. If such changes occur, we issue a new user manual with a new product number.

## ■ Product Application

### ⚠ Caution

- This product is not designed or manufactured for machines or systems intended to sustain human life.
- This product is manufactured under strict quality control conditions. Nevertheless, install safety devices if installing the device in a facility where product malfunctions may result in a major accident or a significant loss.

## ■ EEPROM Lifespan

### ⚠ Caution

- The EEPROM is rewritable up to 1 million times for the purpose of recording parameter settings and other information. The servo drive may malfunction if the total number of the following tasks exceeds 1 million, depending on the lifespan of the EEPROM.
  - EEPROM recording as a result of parameter changes
  - EEPROM recording as a result of an alarm

## ■ Responding to international regulations

**L7 Series responds to international regulations with standard models.**

Model	Low Voltage Directive	EMC Directive
L7NA001B	EN61800-5-1	EN61800-3
L7NA002B		
L7NA004B		
L7NA008B		
L7NA010B		
L7NA020B		
L7NA035B		
L7NA050B		

※ 1 : For more information, please feel free to ask LS Mecapion.

※ 2 : Please follow the regulations of destination when exporting.



# Table of Contents

<b>1. Product Configuration.....</b>	<b>1-1</b>
1.1 Product Verification.....	1-1
1.2 Parts.....	1-3
1.2.1 Servo Motor Parts.....	1-3
1.2.2 Servo Drive Parts.....	1-4
1.3 Connector Diagram.....	1-8
<b>2. Installation.....</b>	<b>2-1</b>
2.1 The Servo Motor.....	2-1
2.1.1 Operating Environment.....	2-1
2.1.2 Preventing Impact.....	2-1
2.1.3 Motor Connection.....	2-1
2.1.4 The Load Device Connection.....	2-2
2.1.5 Cable Installation.....	2-2
2.2 The Servo Drive.....	2-3
2.2.1 Operating Environment.....	2-3
2.2.2 Wiring the Control Panel.....	2-4
2.2.3 Power Supply Wiring.....	2-5
<b>3. Wiring.....</b>	<b>3-1</b>
3.1 Internal Diagram.....	3-1
3.1.1 L7N Drive Block Diagram [L7NA001B - -7NA004B].....	3-1
3.1.2 L7N Drive Block Diagram [L7NA008B - -7NA035B].....	3-2
3.1.3 L7N Drive Block Diagram [L7NA050B].....	3-3
3.2 Power Supply Wiring.....	3-4
3.2.1 L7N Drive Wiring Diagram [L7NA001B - -7NA035B].....	3-4
3.2.2 L7 Drive Wiring Diagram [L7N050B].....	3-5
3.2.3 Power Circuit Electrical Components.....	3-6
3.3 Timing Diagram.....	3-10
3.3.1 Timing Diagram During Power Input.....	3-10
3.3.2 Timing Diagram During an Alarm Trigger.....	3-11
3.4 Wiring the Control Signals.....	3-12
3.4.1 The Contact Input Signal.....	3-12
3.4.2 The Contact Output Signal.....	3-12
3.5 Connecting Serial Encoder Signals (CN2).....	3-13
3.5.1 APCS-E□□□CS Cable.....	3-13
3.5.2 APCS-E□□□DS Cable.....	3-13
3.5.3 APCS-E□□□ES Cable.....	3-14
3.6 Connecting Multi-turn Encoder Signals (CN2).....	3-14
3.6.1 APCS-E□□□CS1 Cable.....	3-14
3.6.2 APCS-E□□□DS1 Cable.....	3-15
3.6.3 APCS-E□□□ES1 Cable.....	3-15
3.7 Connecting the Input/Output Signals.....	3-16
3.7.1 The Names and Functions of the Input Signals (CN1).....	3-16



3.7.2	The Names and Functions of the Output Signals (CN1).....	3-17
3.7.3	Layout of the Input/Output Signal Connectors.....	3-18
3.7.4	The Names and Functions of Safety Function Signals (CN6).....	3-18
3.7.5	The Connector Layout of Safety Function Signals (CN6).....	3-18
3.7.6	Operation Method of Safety Function Signals (CN6).....	3-19
3.8	EtherCAT Connection Example .....	3-20
3.8.1	Example Connection.....	3-20
3.8.2	EtherCAT Connectors and the Pin Map.....	3-21
3.9	Example of connecting to PLC .....	3-23
3.9.1	LSIS – PN8B.....	3-23
<b>4.</b>	<b>How to use the Loader .....</b>	<b>4-24</b>
4.1	Name and Function of each parts.....	4-24
4.2	Status Summary Display.....	4-1
4.3	Display FND Output Object .....	4-3
<b>5.</b>	<b>EtherCAT Communication .....</b>	<b>5-4</b>
5.1	The Structure of CANopen over EtherCAT .....	5-4
5.2	The EtherCAT State Machine .....	5-5
5.3	LED State .....	5-6
5.4	Data Type .....	5-7
5.5	PDO Mapping .....	5-8
5.6	Synchronization Using the DC (Distributed Clock).....	5-10
5.7	Emergency Messages .....	5-14
<b>6.</b>	<b>CiA402 Drive Profile .....</b>	<b>6-1</b>
6.1	The State Machine.....	6-1
6.2	Operation Modes .....	6-4
6.3	Position Control Modes.....	6-5
6.3.1	Profile Position Mode .....	6-5
6.3.2	Interpolated Position Mode .....	6-9
6.3.3	Cyclic Synchronous Position Mode .....	6-11
6.4	Homing.....	6-13
6.5	Velocity Control Mode.....	6-17
6.5.1	Profile Velocity Mode.....	6-17
6.5.2	Cyclic Synchronous Velocity Mode .....	6-19
6.6	Torque Control Modes .....	6-21
6.6.1	Profile Torque Mode .....	6-21
6.6.2	Cyclic Synchronous Torque Mode.....	6-23
6.7	The Torque Limit Function .....	6-25
6.8	Digital Input/Output.....	6-26
6.9	Touch Probe Function.....	6-27
<b>7.</b>	<b>L7 Drive Setup .....</b>	<b>7-1</b>
7.1	Setting System Parameters .....	7-1
7.2	Configuring Control Parameters .....	7-5

7.2.1	The Inertia Ratio Setting [0x2100] .....	7-5
7.2.2	The Position Control Gain .....	7-6
7.2.3	The Speed Control Gain.....	7-7
7.2.4	The Torque Command Filter Time Constant Time [0x210C] .....	7-8
7.2.5	Gain 1 ↔ Gain 2 Transfer Mode [0x210D] .....	7-8
7.2.6	Gain 1 ↔ Gain 2 Transfer Time [0x210E].....	7-8
7.2.7	P/PI Transfer Mode [0x210D] .....	7-8
7.2.8	Resonance Avoidance Operations [0x210F], [0x2110], [0x2111] .....	7-9
7.3	Setting the Input/Output Contact Point Parameters .....	7-10
7.4	Setting Speed Operation Parameters .....	7-12
7.4.1	Acceleration/Deceleration Time.....	7-12
7.4.2	The S-Curve Operation [0x2304] .....	7-12
7.4.3	The Manual JOG Operation Speed [0x2305] .....	7-12
7.5	Setting Position Operation Parameters.....	7-12
7.5.1	Backlash Compensation [0x2403].....	7-12
7.6	Setting Parameters for L7N Built-in Functions .....	7-13
7.6.1	Checking/Deleting the Alarm History [0x2700] .....	7-13
7.6.2	Auto Gain Tuning [0x2701].....	7-13
7.6.3	Absolute Encoder Reset [0x2702] .....	7-13
<b>8.</b>	<b>Object Dictionary .....</b>	<b>8-1</b>
8.1	The Object Dictionary List.....	8-1
8.2	General Objects.....	8-4
	0x1000, Device Type .....	8-4
	0x1001, Error Register .....	8-4
	0x1008, Manufacturer Device Name .....	8-4
	0x1009, Hardware Version .....	8-5
	0x100A, Software Version .....	8-5
	0x1010, Store Parameters .....	8-6
	※ When using this function, delay time will occur by EEPROM save .....	8-7
	0x1011, Restore Default Parameters.....	8-7
	0x1018, Identity Object.....	8-9
8.3	PDO Mapping Objects .....	8-10
	0x1600 to 0x1603, Receive PDO Mapping .....	8-11
	0x1A00 to 0x1A03, Transmit PDO Mapping .....	8-13
8.4	Sync Manager Communication Objects.....	8-17
	0x1C00, Sync Manager Communication Type.....	8-17
	0x1C10 to 0x1C13, Sync Manager PDO Assignment .....	8-18
	0x1C32, Sync Manager 2 Synchronization .....	8-20
	0x1C33, Sync Manager 3 Synchronization .....	8-22
8.5	Manufacturer Specific Objects .....	8-24
	0x2000, Motor ID.....	8-24
	0x2001, Encoder Type.....	8-25
	0x2002, Encoder Resolution.....	8-25
	0x2003, Power Fail Mode .....	8-25
	0x2004, RST Power Fail Check Time .....	8-26
	0x2005, 7SEG Display Object .....	8-26
	0x2006, Regenerative Resistor De-rating Factor .....	8-26

0x2007, Regenerative Resistor Value .....	8-27
0x2008, Regenerative Resistor Capacity .....	8-27
0x2009, Overload Check Base .....	8-27
0x200A, Overload Warning Level .....	8-27
0x200B, PWM Off Delay .....	8-28
0x200C, Dynamic Brake Control Mode .....	8-28
0x200D, Basic Function Configuration .....	8-28
0x200E, Position Scale Numerator .....	8-29
0x200F, Position Scale Denominator .....	8-29
0x2010, Velocity Scale Numerator .....	8-29
0x2011, Velocity Scale Denominator .....	8-29
0x2012, Acceleration Scale Numerator .....	8-30
0x2013, Acceleration Scale Denominator .....	8-30
0x2015, U Phase Current Offset .....	8-32
0x2016, V Phase Current Offset .....	8-33
0x2017, W Phase Current Offset .....	8-33
0x2100, Inertia Ratio Setting .....	8-33
0x2101, Position P Gain 1 .....	8-34
0x2102, Position P Gain 2 .....	8-34
0x2103, The Position Command Filter Time Constant .....	8-34
0x2104, Position Feed-forward Gain .....	8-34
0x2105, The Position Feed-forward Filter Time Constant .....	8-35
0x2106, Speed P Gain 1 .....	8-35
0x2107, Speed P Gain 2 .....	8-35
0x2108, Speed Integral Time Constant 1 (Speed I Gain 1 Time Constant) .....	8-35
0x2109, Speed Integral Time Constant 2 (Speed I Gain 2 Time Constant) .....	8-36
0x210A, The Speed Command Filter Time Constant .....	8-36
0x210B, The Speed Feedback Filter Time Constant .....	8-36
0x210C, The Torque Command Filter Time Constant .....	8-36
0x210D, Conversion Mode .....	8-37
0x210E, The Gain Conversion Time .....	8-38
0x210F, The Resonance Avoidance Operation (Notch Filter Use) .....	8-38
0x2110, The Resonance Avoidance Frequency (Notch Filter Frequency) .....	8-38
0x2111, The Resonance Avoidance Range (Notch Filter Bandwidth) .....	8-38
0x2112, The Velocity Limit Switch .....	8-39
0x2113, The Velocity Limit Value .....	8-39
0x2114, P Control Conversion Torque (Torque Switch Value) .....	8-39
0x2115, The P Control Conversion Speed (Speed Switch Value) .....	8-39
0x2116, P Control Conversion Acceleration (Acceleration Switch Value) .....	8-39
0x2117, P Control Conversion Position Error (Following Error Switch Value) .....	8-39
0x2200, Input Port Define 1 .....	8-40
0x2201, Input Port Define 2 .....	8-40
0x2202, Output Port Define 1 .....	8-40
0x2203, Output Port Define 2 .....	8-40
0x2204, The Input Port Logic Set .....	8-40
0x2205, The Output Port Logic Set .....	8-41
0x2206, The Zero Speed Range .....	8-41
0x2207, The Break Output Speed .....	8-41
0x2208, The Break Output Delay Time .....	8-42
0x2300, The Index (Z-phase) Pulse Detection Operation Speed (Index Pulse Search Speed) .....	8-42
0x2301, The Speed Command Acceleration Time .....	8-42

0x2302, The Speed Command Deceleration Time.....	8-43
0x2303, The Speed Command S-curve Time .....	8-43
0x2304, The Speed Operation Pattern (Acceleration Pattern) .....	8-43
0x2305, The Manual JOG Operation Speed (JOG Speed) .....	8-43
0x2306, JOG Operation Speed 1 (Program JOG Speed 1) .....	8-44
0x2307, JOG Operation Speed 2 (Program JOG Speed 2) .....	8-44
0x2308, JOG Operation Speed 3 (Program JOG Speed 3) .....	8-44
0x2309, JOG Operation Speed 4 (Program JOG Speed 4) .....	8-44
0x230A, JOG Operation Time 1 (Program JOG Time 1) .....	8-44
0x230B, JOG Operation Time 2 (Program JOG Time 2) .....	8-44
0x230C, JOG Operation Time 3 (Program JOG Time 3) .....	8-45
0x230D, JOG Operation Time 4 (Program JOG Time 4) .....	8-45
0x2402, The Position Limit Function .....	8-45
0x2403, Backlash Compensation .....	8-45
0x2600, The Current Speed (RPM) .....	8-45
0x2601, The Command Speed (RPM) .....	8-46
0x2602, The Tracking Position Pulse (Feedback Pulse) .....	8-46
0x2603, The Position Command Pulse .....	8-46
0x2604, The Remaining Position Pulse (Following Error) .....	8-46
0x2605, The Input Command Frequency .....	8-46
0x2606, Current Operation Torque .....	8-47
0x2607, Current Command Torque .....	8-47
0x2608, Accumulated Overload .....	8-47
0x2609, The Maximum Instantaneous Load .....	8-47
0x260A, The Torque Limit .....	8-47
0x260B, The DC-Link Voltage .....	8-48
0x260C, Regenerative Overload .....	8-48
0x260D, The Single-turn Data (Pulse) Display (Single-turn Data) .....	8-48
0x260E, The Single-turn Data (Degree) Display (Single-turn Data (deg)) .....	8-48
0x2610, The Room Temperature Display .....	8-49
0x2611, The Motor Rated Speed Display .....	8-49
0x2612, The Motor Maximum Speed Display .....	8-49
0x2613, The Motor Rated Current Display .....	8-49
0x2614, The U Phase Current Offset Display .....	8-50
0x2615, The V Phase Current Offset Display .....	8-50
0x2616, The FPGA Version Display .....	8-50
0x2617, External Encoder Position Feedback .....	8-50
0x2618, External Encoder Following Error .....	8-50
0x2700, Read/Clear the Alarm History .....	8-51
0x2701, Auto Gain Tuning (Auto-tuning) .....	8-52
0x2702, Reset Absolute Encoder .....	8-53
0x2703, Calibrate Current Offset .....	8-53
<b>8.6 CiA402 Objects.....</b>	<b>8-54</b>
0x603F, Error Code .....	8-54
0x6040, Controlword .....	8-54
Details on Bits 0 to 3 .....	8-55
Details on Bits 4 to 9 .....	8-56
0x6041, Statusword .....	8-57
0x605A, The Quick Stop Option Code .....	8-61
0x605B, The Shutdown Option Code .....	8-62

0x605C, The Disable Operation Option Code.....	8-62
0x605D, The Halt Option Code.....	8-63
0x605E, The Fault Reaction Option Code .....	8-63
0x6060, Modes of Operation .....	8-64
0x6061, The Modes of Operation Display.....	8-64
0x6062, The Position Demand Value.....	8-65
0x6063, The Position Actual Internal Value.....	8-65
0x6064, The Position Actual Value .....	8-65
0x6065, The Position Error Range (Following Error Window).....	8-65
0x6066, Position Error Timeout (Following Error Time Out).....	8-66
0x6067, The Position Reached Range (Position Window).....	8-66
0x6068, The Position Reached Time (Position Window Time).....	8-66
0x606B, The Velocity Demand Value.....	8-66
0x606C, The Actual Velocity Value .....	8-66
0x606D, The Velocity Reached Range (Velocity Window).....	8-67
0x606E, The Velocity Window Time.....	8-67
0x6071, The Target Torque.....	8-67
0x6072, Maximum Torque .....	8-67
0x6074, The Torque Demand Value.....	8-68
0x6076, The Motor Rated Torque .....	8-68
0x6077, The Torque Actual Value .....	8-68
0x607A, The Target Position.....	8-68
0x607C, The Home Offset.....	8-69
0x607D, The Software Position Limit.....	8-69
0x607F, Maximum Profile Velocity .....	8-70
0x6081, The Profile Velocity .....	8-70
0x6083, Profile Acceleration .....	8-70
0x6084, Profile Deceleration.....	8-71
0x6085, Quick Stop Deceleration.....	8-71
0x6087, The Torque Slope.....	8-71
0x6098, The Homing Method.....	8-71
0x6099, Homing Speeds.....	8-72
0x609A, Homing Acceleration.....	8-72
0x60B1, The Velocity Offset.....	8-73
0x60B2, The Torque Offset.....	8-73
0x60B8, The Touch Probe Function.....	8-73
0x60B9, The Touch Probe Status.....	8-74
0x60BA, The Touch Probe 1 Positive Edge Position Value .....	8-75
0x60BB, The Touch Probe 1 Negative Edge Position Value .....	8-75
0x60BC, The Touch Probe 2 Positive Edge Position Value .....	8-75
0x60BD, The Touch Probe 2 Negative Edge Position Value .....	8-75
0x60C1, The Interpolation Data Record.....	8-76
0x60C2, The Interpolation Time Period.....	8-76
0x60E0, The Positive Torque Limit Value.....	8-77
0x60E1, The Negative Torque Limit Value .....	8-77
0x60F4, The Following Error Actual Value .....	8-77
0x60FC, The Position Demand Internal Value .....	8-77
0x60FD, The Digital Input .....	8-78
0x60FE, The Digital Output.....	8-78
0x60FF, The Target Velocity.....	8-80
0x6502, Supported Drive Modes .....	8-80

<b>9.</b>	<b>Handling and Operation .....</b>	<b>9-1</b>
<b>9.1</b>	<b>Operation Checklist .....</b>	<b>9-1</b>
<b>9.1.1</b>	<b>Wiring Checklist .....</b>	<b>9-1</b>
<b>9.1.2</b>	<b>Drive Signal (CN1) Wiring Checklist.....</b>	<b>9-1</b>
<b>9.1.3</b>	<b>Surrounding Environment Checklist .....</b>	<b>9-1</b>
<b>9.1.4</b>	<b>Machine Status Checklist .....</b>	<b>9-1</b>
<b>10.</b>	<b>Product Specifications .....</b>	<b>10-1</b>
<b>10.1</b>	<b>The Servo Motor.....</b>	<b>10-1</b>
<b>10.1.1</b>	<b>Product Features .....</b>	<b>10-2</b>
<b>10.1.2</b>	<b>10-2</b>	
<b>10.1.3</b>	<b>Outline Diagram (For the drawing of Oilseal Type, it is available on request).....</b>	<b>10-31</b>
<b>10.2</b>	<b>The Servo Drive .....</b>	<b>10-48</b>
<b>10.2.1</b>	<b>Product Features .....</b>	<b>10-48</b>
<b>10.3</b>	<b>Outline Diagram .....</b>	<b>10-50</b>
<b>10.4</b>	<b>Options and Peripheral Devices .....</b>	<b>10-52</b>
<b>11.</b>	<b>Maintenance and Inspection .....</b>	<b>11-66</b>
<b>11.1</b>	<b>Maintenance and Inspection.....</b>	<b>11-66</b>
<b>11.1.1</b>	<b>Precautions.....</b>	<b>11-66</b>
<b>11.1.2</b>	<b>What to Inspect .....</b>	<b>11-66</b>
<b>11.1.3</b>	<b>Replacing Parts.....</b>	<b>11-68</b>
<b>11.2</b>	<b>Diagnosing and Troubleshooting Abnormalities .....</b>	<b>11-69</b>
<b>11.2.1</b>	<b>The Servo Motor .....</b>	<b>11-69</b>
<b>11.2.2</b>	<b>The Servo Drive .....</b>	<b>11-70</b>
<b>12.</b>	<b>Appendix .....</b>	<b>12-1</b>
<b>12.1</b>	<b>Motor Types and IDs .....</b>	<b>12-1</b>
<b>12.2</b>	<b>Test Drive Procedure .....</b>	<b>12-4</b>

# 1. Product Configuration

## 1.1 Product Verification

1. Check the name tag to verify that the product received matches the model ordered.
  - Does the servo drive's name plate match?
  - Does the servo motor's name plate match?
2. Check the product components and options.
  - Are the type and length of cables correct?
  - Does the regenerative resistor conform to the required standard?
    - ♦ Is the shape of the shaft correct?
    - ♦ Are there any abnormalities after mounting the oil seal or brake?
    - ♦ Are the gearbox and the gear ratios correct?
    - ♦ Is the encoder format correct?
3. Check the exterior of the device.
  - Are there any foreign substances or humidity in the device?
  - Is there any discoloration, contaminant, damage or disconnected wire?
  - Are the bolts tightly fastened to the joints?
  - Is there any abnormal sound or excessive friction during operation?

### ■ The Servo Drive Product Format

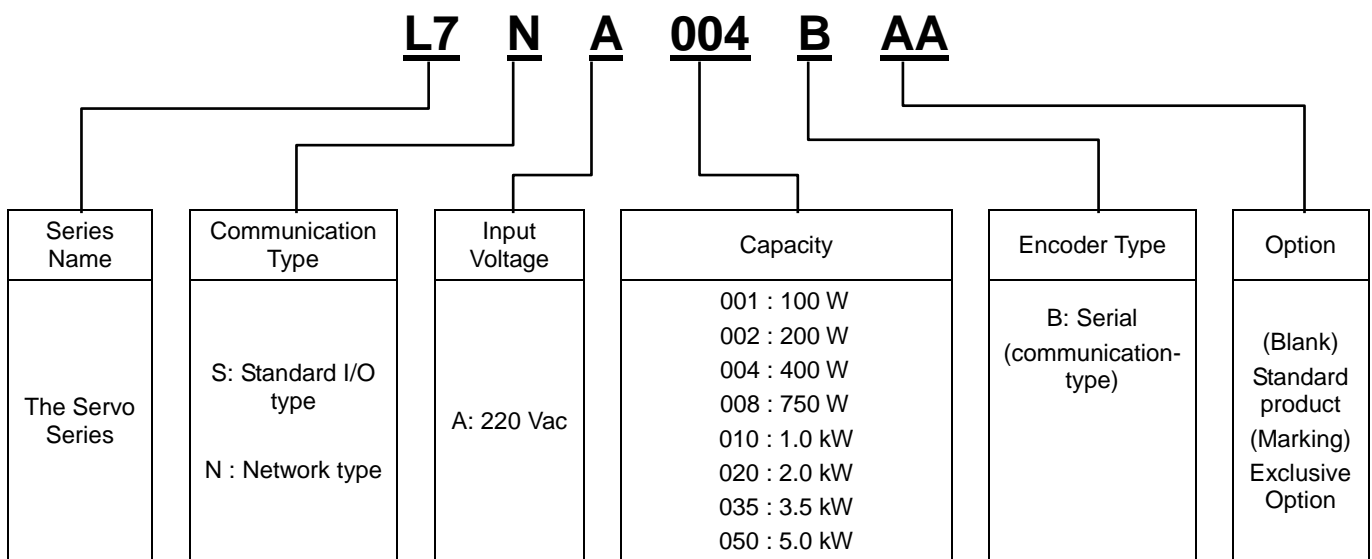

■ Servo Motor Product Format

# APM – S B 04 A E K 1 G1 03

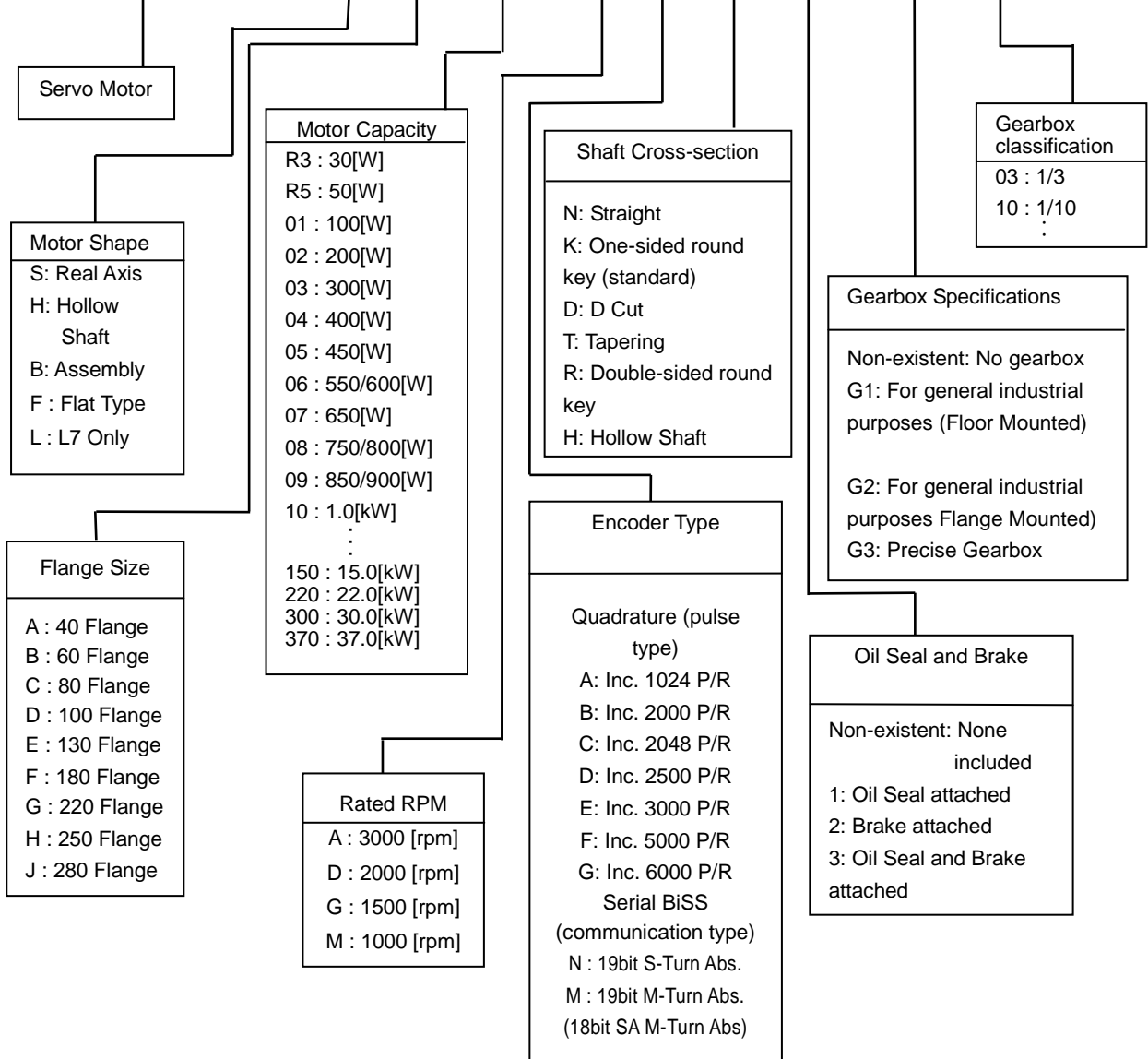



## 1.2 Parts

### 1.2.1 Servo Motor Parts

#### ■ 80 Flange or below

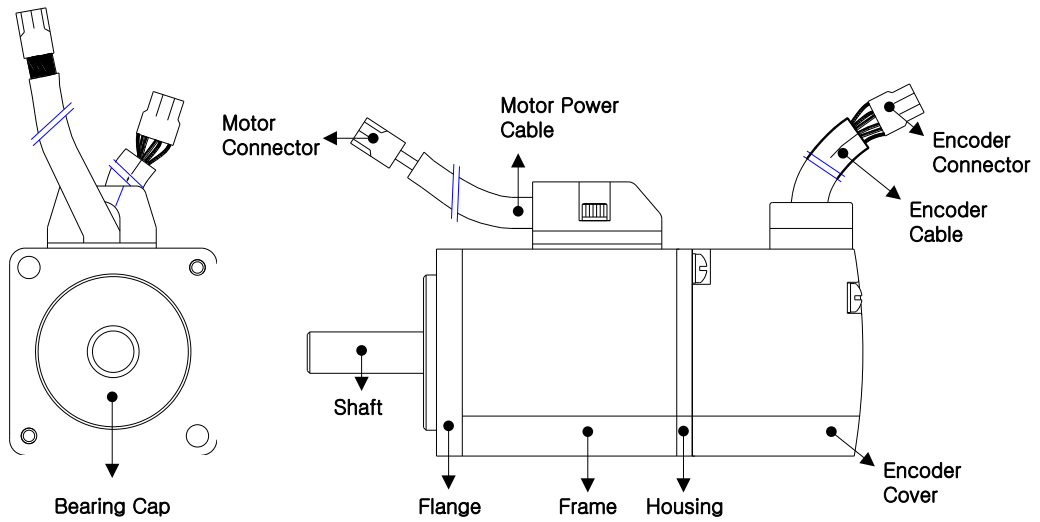

#### ■ 80 Flange or below(Flat Type)

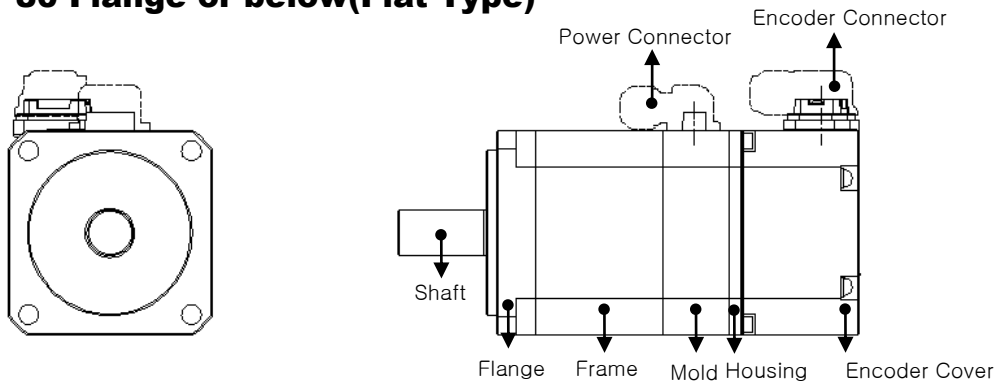

#### ■ 130 Flange or higher

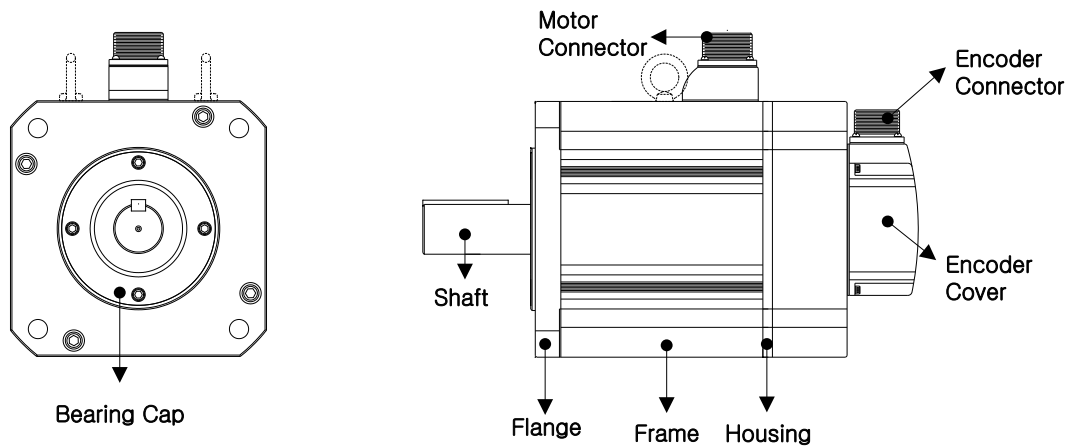

## 1.2.2 Servo Drive Parts

### ■ L7NA001B, L7NA002B, L7NA004B

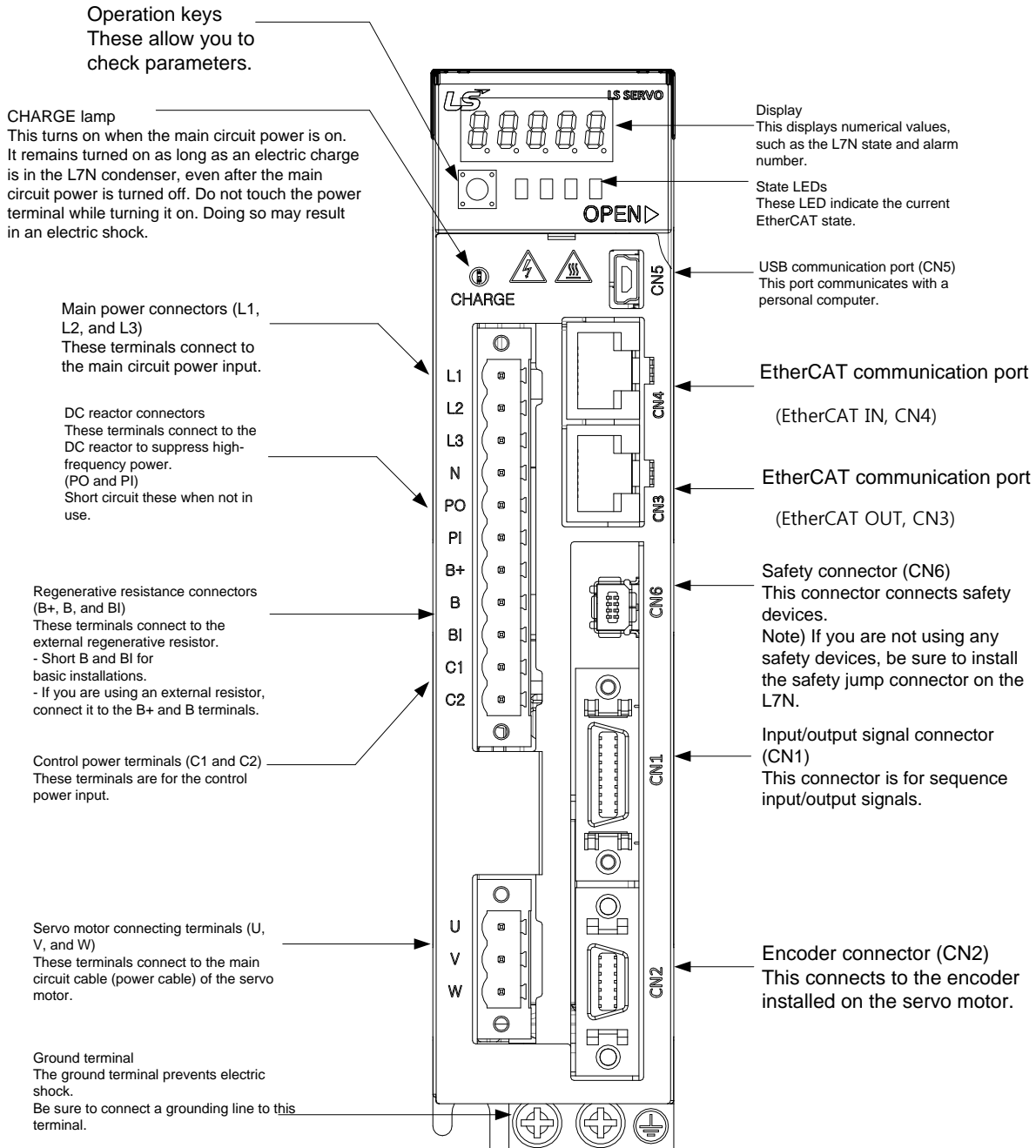

## ■ L7NA008B,L7NA010B

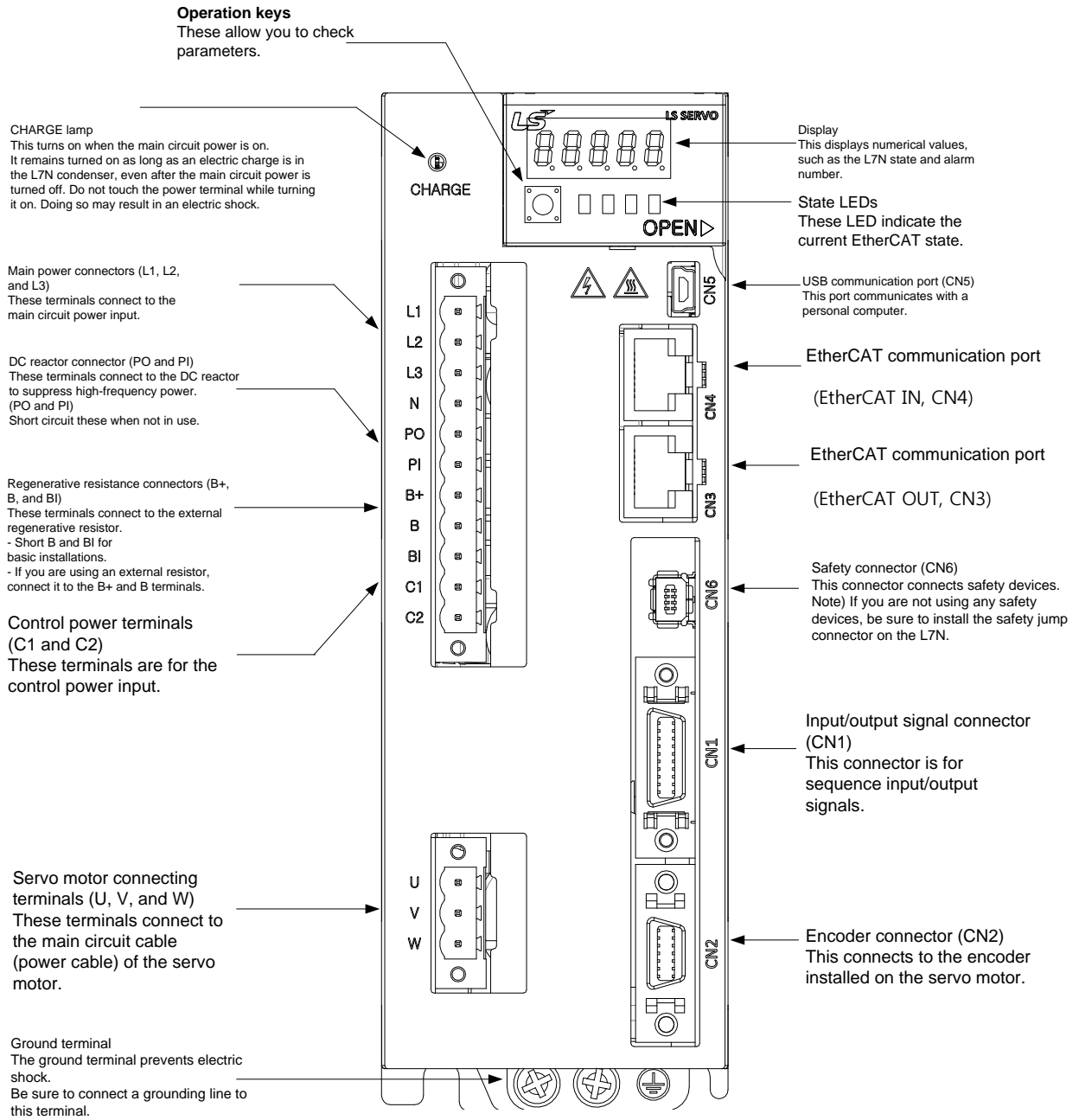

## ■ L7NA020B,L7NA035B

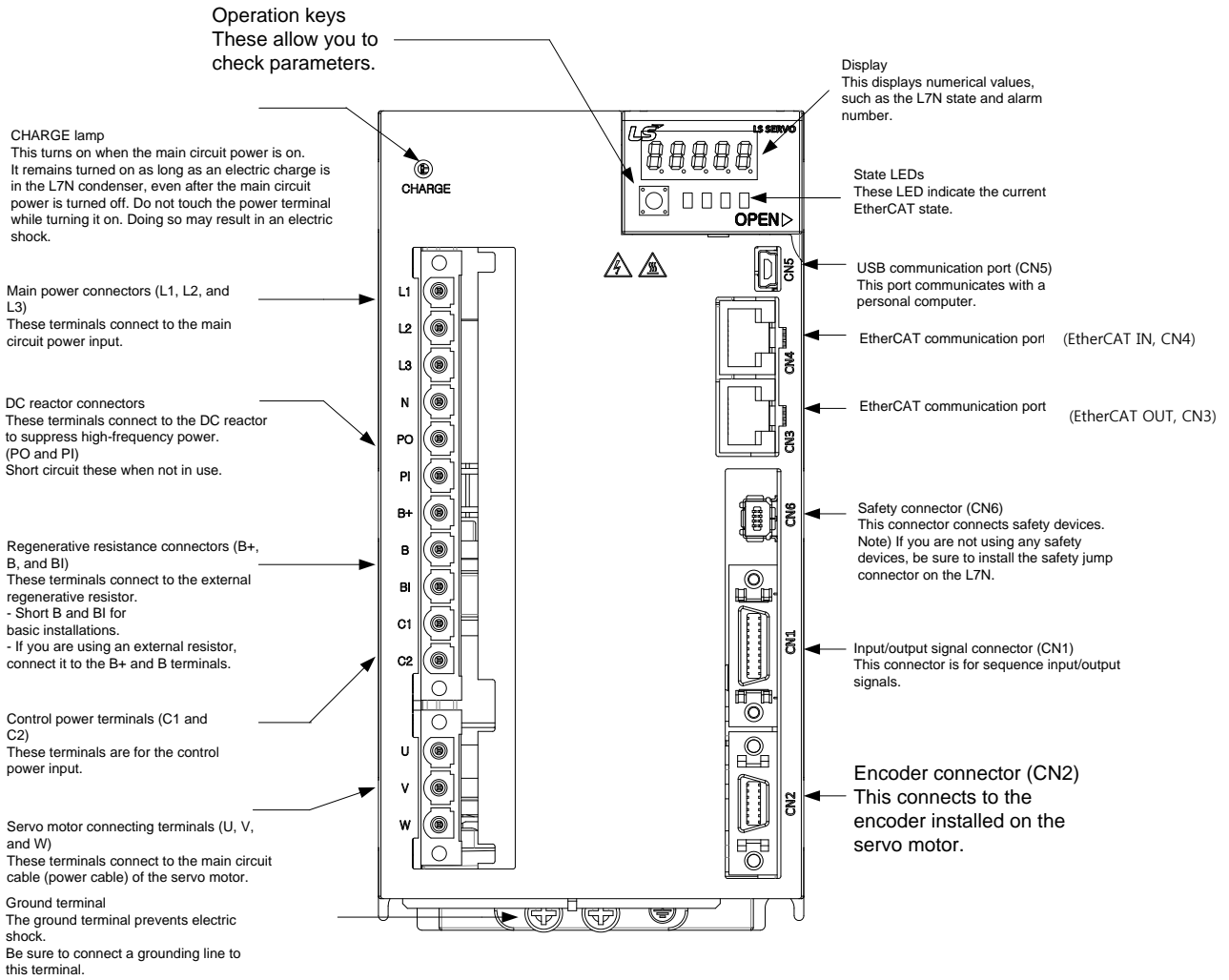

■ L7NA050B

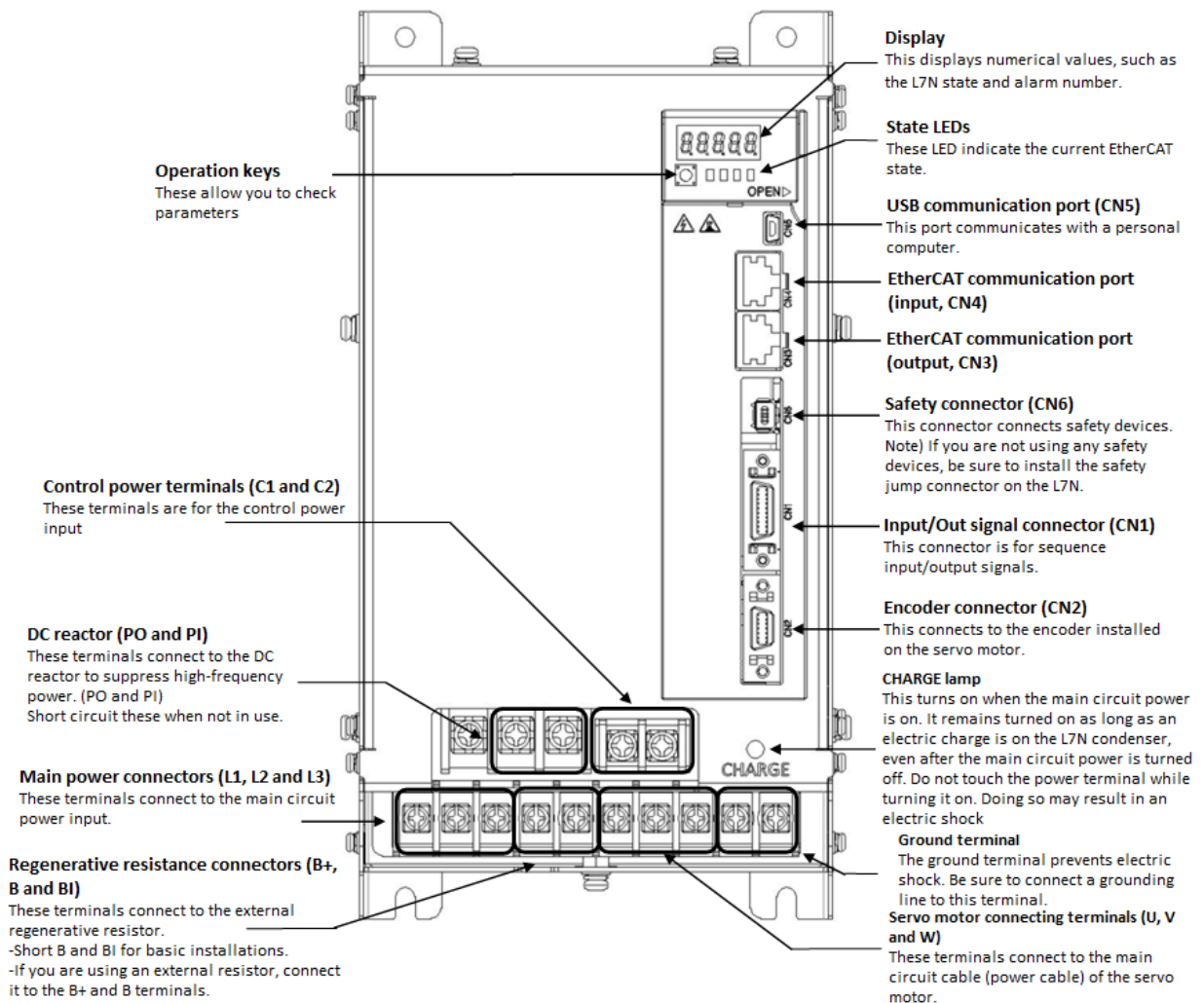

### 1.3 Connector Diagram

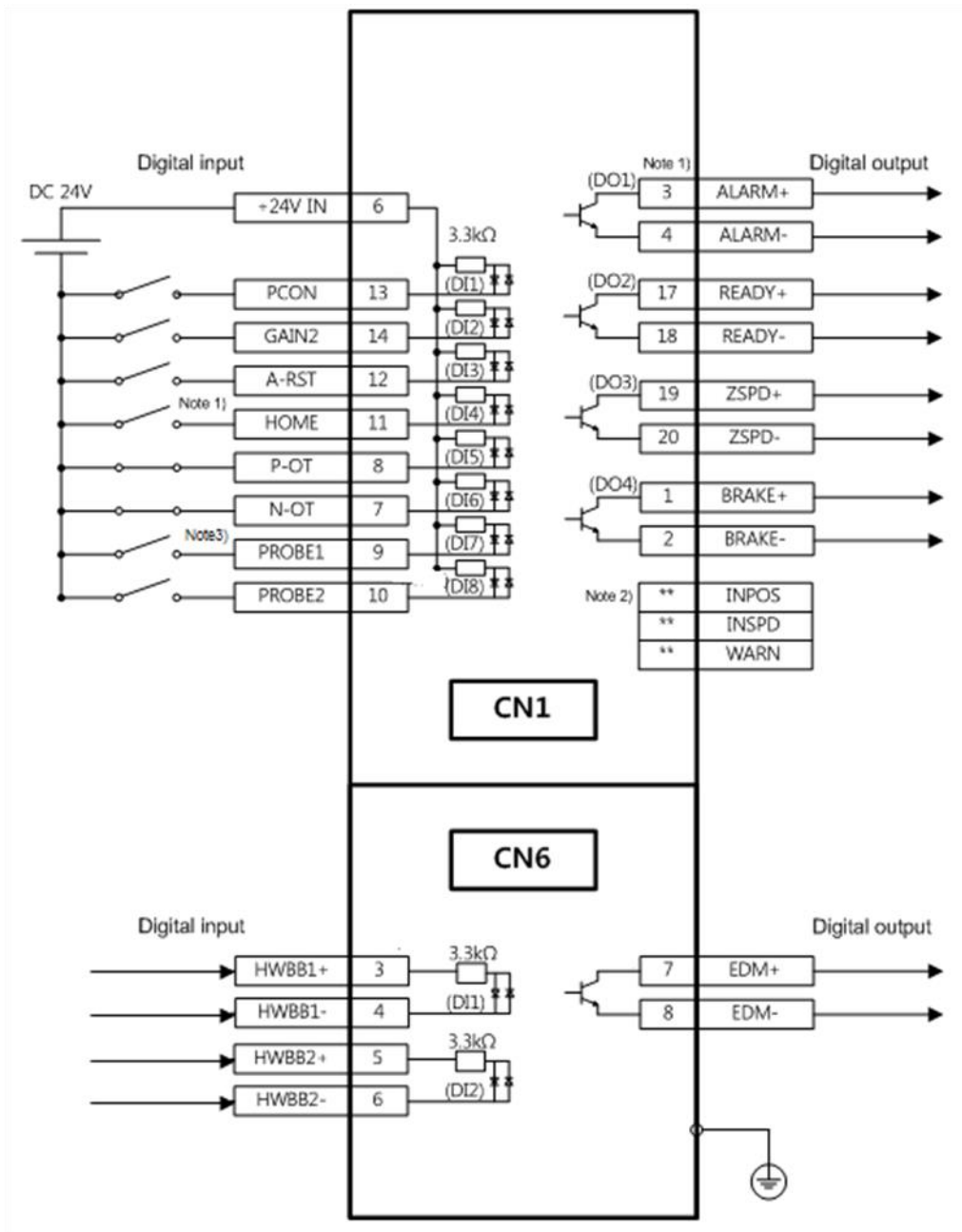

Note 1) The input signals (DI4~DI8, output signals (DO1~DO4) are the factory default signals.

Note 2) \*\* is unallocated signals. You can allocate those signals by setting I/O signal allocation.

Refer to 6.3 I/O Contacts parameter setting for more information.

Note 3) Input signal DI7 and DI8 are always allocated as PROBE1, PROBE2 regardless of the input signal allocation setting.

## 2. Installation

### 2.1 The Servo Motor

#### 2.1.1 Operating Environment

Item	Requirements	Notes
Ambient temperature	0 ~ 40[°C]	Consult with our technical support team to customize the product if temperatures in the installation environment are outside this range.
Ambient humidity	80% RH or lower	Do not operate this device in an environment with steam.
External vibration	Vibration acceleration 19.6 m/s <sup>2</sup> or below on both the X and Y axis.	Excessive vibrations reduce the lifespan of the bearings.

#### 2.1.2 Preventing Impact

Impact to the motor during installation or handling may damage the encoder.



#### 2.1.3 Motor Connection

- The motor might burn out if it is connected directly to commercial power. Always connect the motor via the specified drive.
- Connect the ground terminals of the motor to either of the two ground terminals inside the drive, and attach the remaining terminal to the type-3 ground.

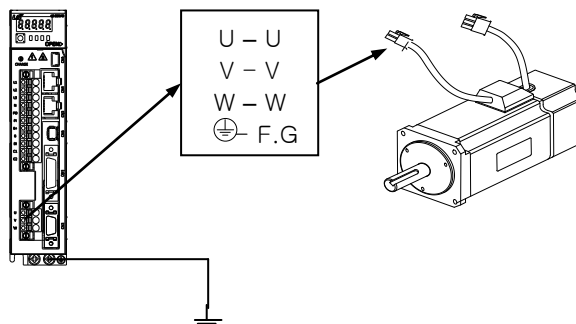

- Connect the U, V, and W terminals of the motor in the same way as the U, V, and W terminals of the drive.
- Ensure that the pins on the motor connector are securely attached.
- In order to protect against moisture or condensation in the motor, make sure that insulation resistance is 10 MΩ (500 V) or higher before installation.

### 2.1.4 The Load Device Connection

For coupling connections: Ensure that the motor shaft and load shaft are aligned within the tolerance range.

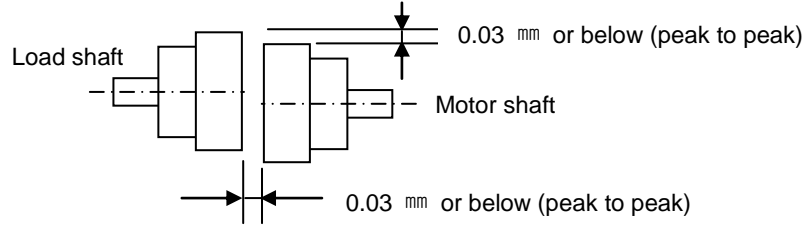

■ For pulley connections:

Flange	Lateral Load		Axial Load		Notes
	N	kgf	N	kgf	
40	148	15	39	4	<p>Nr: 30 mm or below</p> <p>Lateral load</p> <p>Axial load</p>
60	206	21	69	7	
80	255	26	98	10	
130	725	74	362	37	
180	1548	158	519	53	
220	1850	189	781	90	

### 2.1.5 Cable Installation

- For vertical installations, make sure that no oil or water flows into the connecting parts.

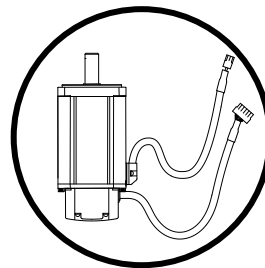
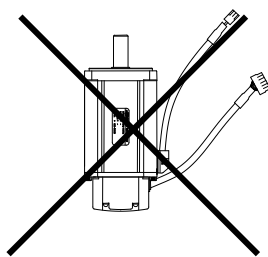

- Do not apply pressure to or damage the cables.
- Use robot cables to prevent swaying when the motor moves.



## 2.2 The Servo Drive

### 2.2.1 Operating Environment

Item	Requirements	Notes
Ambient temperature	0 ~ 50[°C]	<p>⚠ <b>Caution</b></p> <p>⚠ Install a cooling fan on the control panel to maintain an appropriate temperature.</p>
Ambient humidity	90% RH or lower	<p>⚠ <b>Caution</b></p> <p>Condensation or moisture may develop inside the drive during prolonged periods of inactivity and damage it. Remove all moisture before operating the drive after a prolonged period of inactivity.</p>
External vibration	Vibration acceleration 4.9 m/s <sup>2</sup> or lower	Excessive vibration reduces the lifespan of the machine and may cause malfunctions.
Ambient conditions	<ul style="list-style-type: none"> <li>▪ Do not expose the device to direct sunlight.</li> <li>▪ Do not expose the device to corrosive or combustible gases.</li> <li>▪ Do not expose the device to oil or dust.</li> <li>▪ Ensure that the device receives sufficient ventilation.</li> </ul>	

## 2.2.2 Wiring the Control Panel

Comply with the spacing specified in the following figures when installing the control panel.

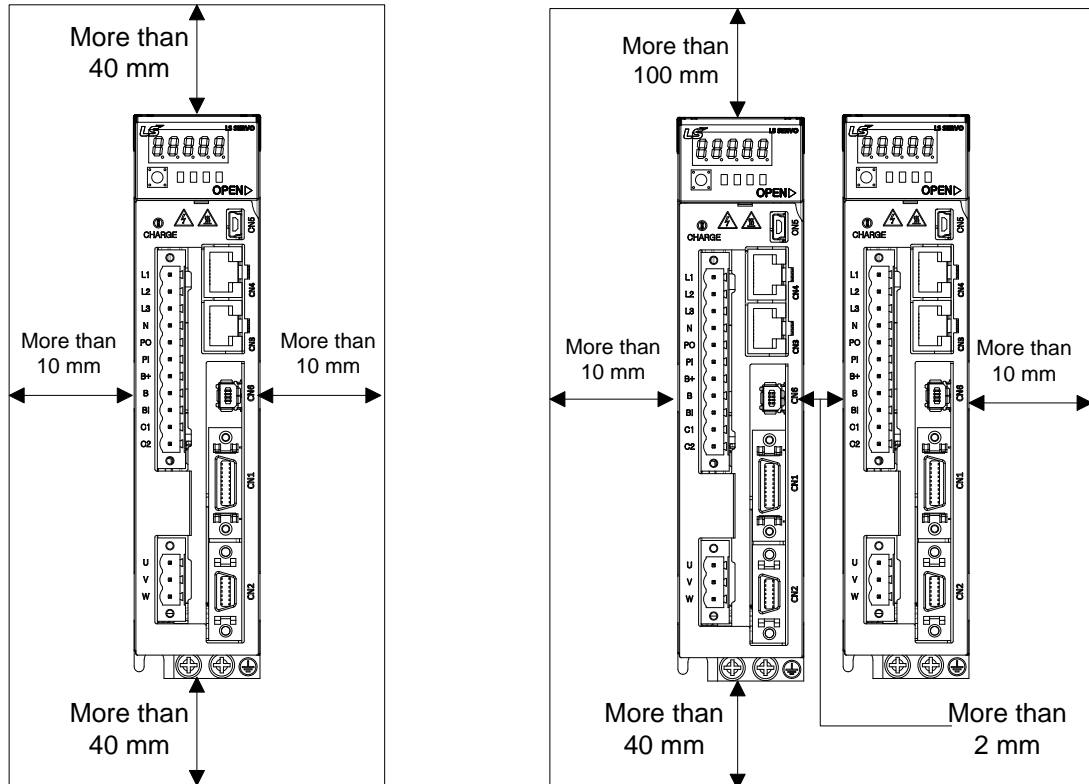

### ⚠ Caution

- Ensure that during installation the heat from the external regenerative resistor does not affect the drive.
- Ensure that the servo drive control panel is flat against the wall during installation.
- Ensure that the metal powder from drilling does not enter the drive when assembling the control panel.
- Ensure that oil, water, and metal dust do not enter the drive through gaps in the casing.
- Protect the control panel by spraying compressed air in areas which accumulate harmful gases or dust.

## 2.2.3 Power Supply Wiring

- Ensure that the input power voltage is within the acceptable range.

<b>⚠ Caution</b>
Overvoltage can damage the drive.

- Connecting commercial power to the U, V and W terminals of the drive may damage the drive. Always supply power via the L1, L2 and L3 terminals.
- Connect short-circuit pins to the B and BI terminals. For external regenerative resistors, remove the short-circuit pins and use standard resistors for the B+ and B terminals.

Model	Resistance Value	Standard Capacity	* Notes
L7NA001B	100 Ω	Built-in 50 W	<b>⚠ Caution</b> For information about resistance during regenerative capacity expansion, refer to Section 9.3, "Optional and Peripheral Devices."
L7NA002B			
L7NA004B			
L7NA008B	40 Ω	Built-in 100 W	
L7NA010B			
L7NA020B	13 Ω	Built-in 150 W	
L7NA035B			

- Configure the system so that the main power (L1, L2, L3) is supplied after the control power (C1, C2). (Refer to Chapter 3, "Wiring.")
- High voltages may remain in the device for sometime even after the main power is disconnected.

<b>⚠ Warning</b>
After disconnecting the main power, ensure that the charge lamp is off before you start wiring. Failure to do so may result in electric shock.

- Always ground the device over the shortest possible distance. Long ground wires are susceptible to noise which may cause the device to malfunction.



### 3. Wiring

#### 3.1 Internal Diagram

##### 3.1.1 L7N Drive Block Diagram [L7NA001B - -7NA004B]

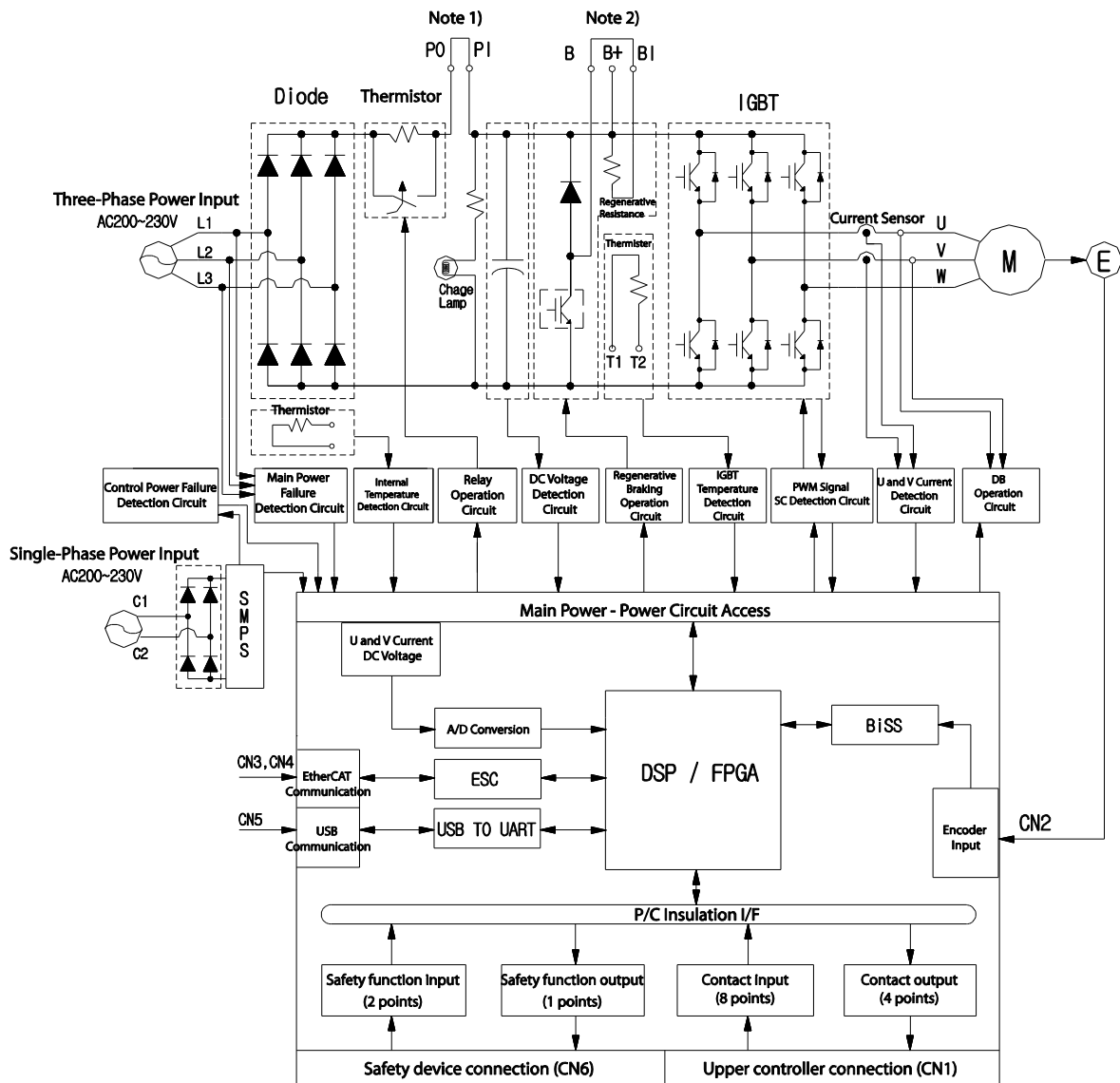

**Note 1)** If using a DC reactor, connect the PO and PI pins.

**Note 2)** If using an external regenerative resistor, remove the B and BI short-circuit pins and connect the B+ and B pins.

### 3.1.2 L7N Drive Block Diagram [L7NA008B - -7NA035B]

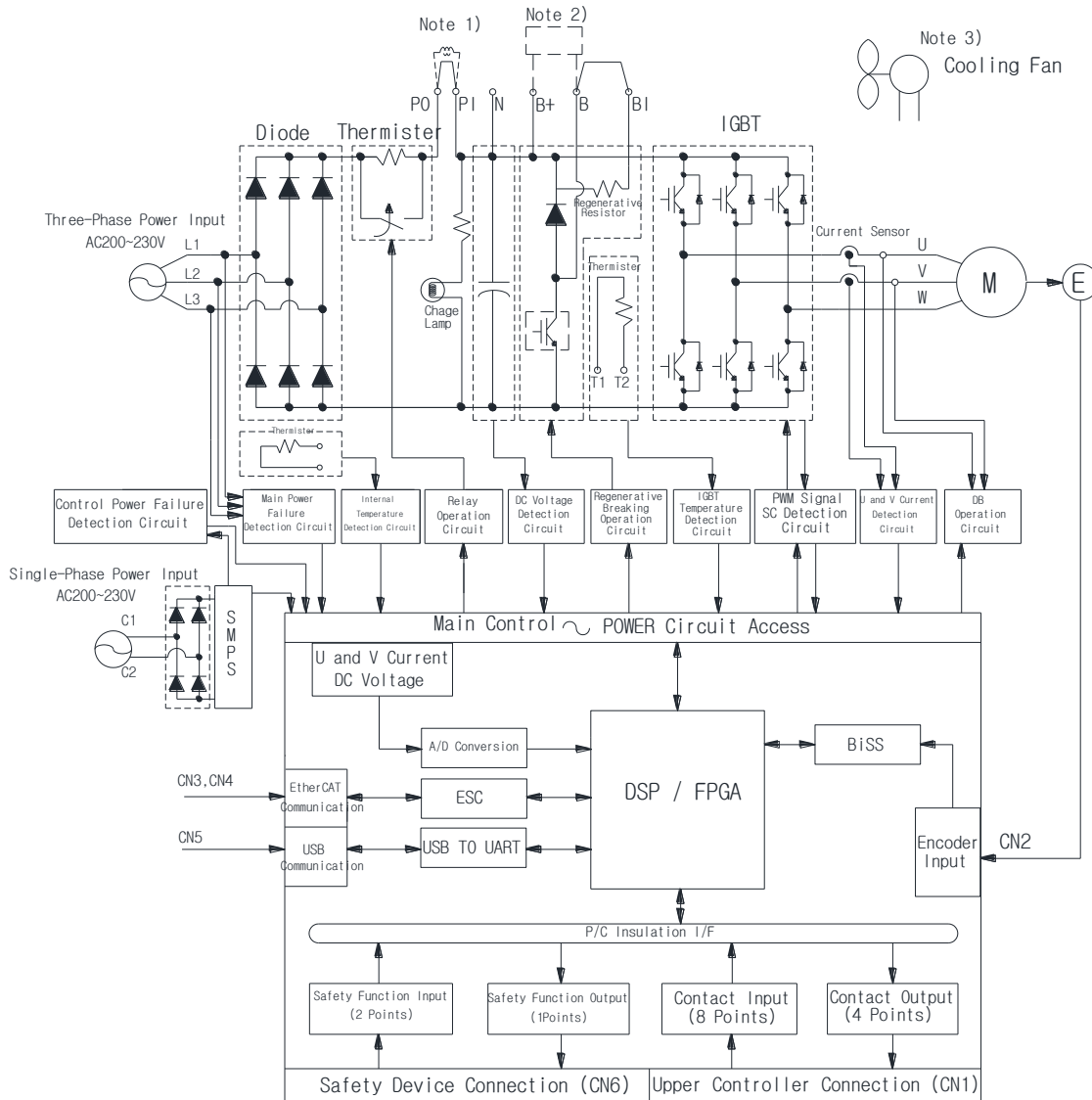

- Note 1)** If using a DC reactor, connect the PO and PI pins.
- Note 2)** If using an external regenerative resistor, remove the B and BI short-circuit pins and connect the B+ and B pins.
- Note 3)** The L7NA008B ~ L7NA035B modesl are cooled by a DC 24V cooling fan.

### 3.1.3 L7N Drive Block Diagram [L7NA050B]

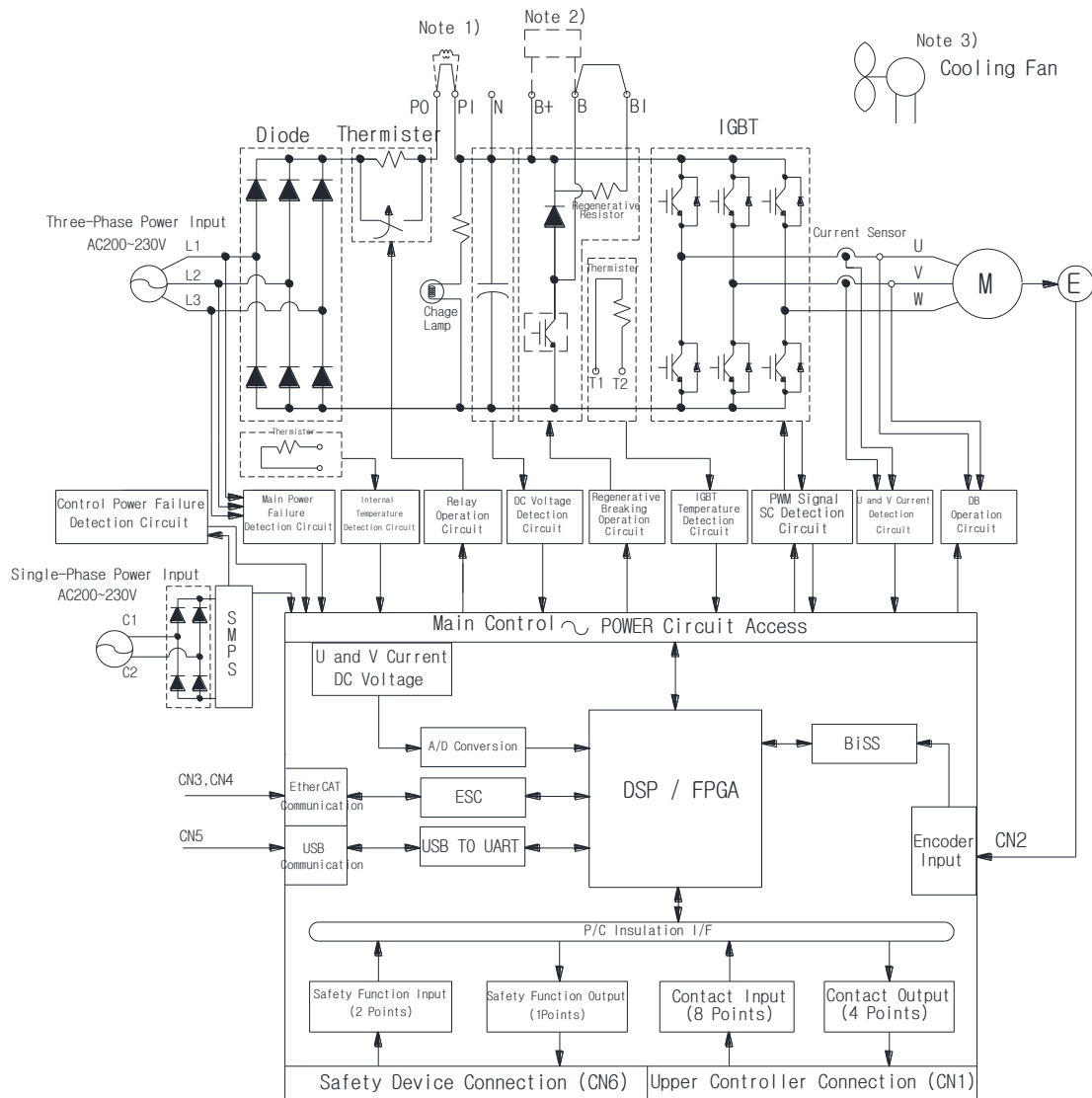

**Note 1)** If using a DC reactor, connect the PO and PI pins.

**Note 2)** If using an external regenerative resistor, remove the B and BI short-circuit pins and connect the B+ and B pins.

**Note 3)** The L7NA050B model is cooled by a DC 24V cooling fan.

## 3.2 Power Supply Wiring

### 3.2.1 L7N Drive Wiring Diagram [L7NA001B - -7NA035B]

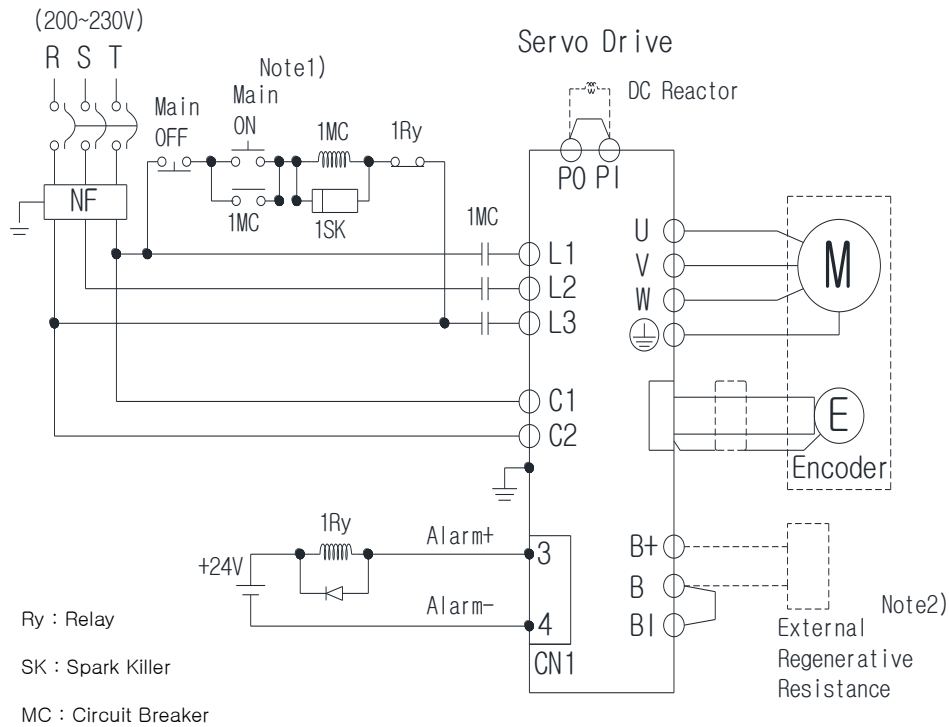

It takes approximately one to two seconds to output an alarm signal after turning on the main power. Accordingly, press and hold the main power ON switch for at least two seconds.

**Note 4)** Check the B and BI short-circuit terminals and the L7NA001B-L7NA004B (50 W, 100 Ω), L7NA008B ~ L7NA010B (100 W, 40 Ω), and L7NA020B ~ L7NA035B (150 W, 13 Ω) regenerative resistors before use. If the regenerative capacity is high because of frequent acceleration and deceleration, open the short-circuit pins (B, BI) and connect an external regenerative resistor to B and B+.

**Note 5)** Remove approximately 7-10 mm of the sheathing from the cables for the main circuit power and attach crimp terminals. (Refer to Section 3.2.2, "Power Circuit Electrical Components.")

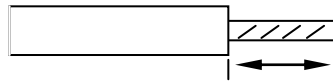

**Note 6)** Press the button on the L7NA001B-L7NA010B drive terminal to attach or remove wires to the main circuit power unit. For the L7NA020B ~ L7NA035B drive, use a (-) flathead screwdriver to attach or remove the wires.



### 3.2.2 L7 Drive Wiring Diagram [L7N050B]

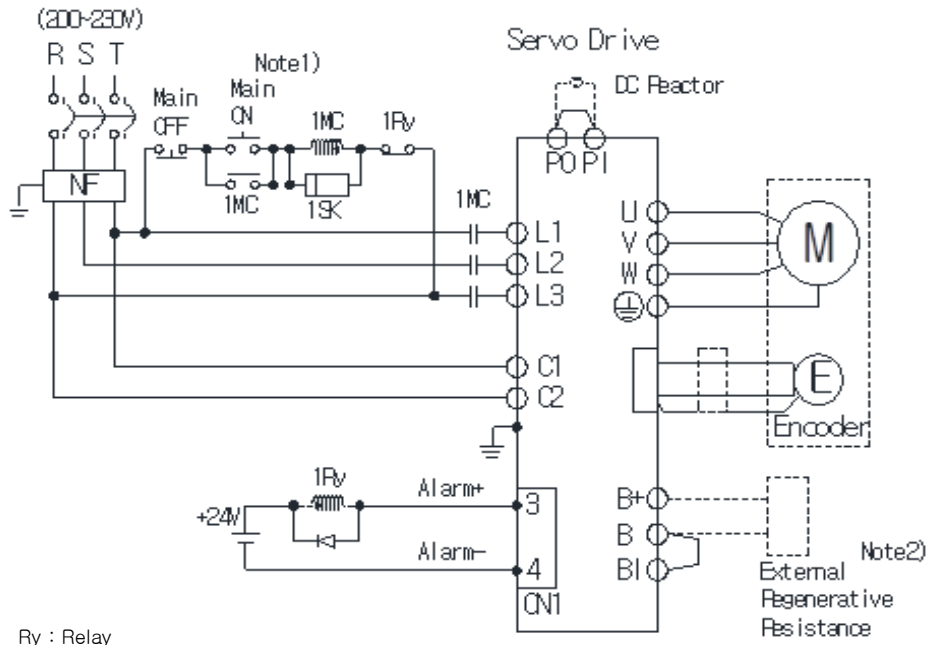

Ry : Relay  
 SK : Spark Killer  
 MC : Circuit Breaker

**Note 1)** It takes approximately one to two seconds to output an alarm signal after turning on the main power. Accordingly, press and hold the main power ON switch for at least two seconds.

**Note 2)** Check the status of connection of internal regenerative resistance (B+.B) before using because L7NA050□(120[W], 6.8[Ω]) has internal regenerative resistance. If the value of regenerative voltage is too high by frequent deceleration and acceleration, install external regenerative resistance on B and B+, B to “NC” hole on the case.

### 3.2.3 Power Circuit Electrical Components

Name		L7NA001B	L7NA002B	L7NA004B	L7NA008B	L7NA010B	L7NA020B	L7NA035B	L7NA050B
MCCB(NFB)		30A Frame 5A (ABE33b/5)		30A Frame 10A (ABE33b/10)	30A Frame 15A (ABE33b/15)		30A Frame 30A (ABE33b/30)		50A Frame 40A(ABE53b/40)
Noise Filter (NF)		TB6-B010LBEI(10A)					TB6-B030NBDC(30A)		TB6- B040A(40A)
DC reactor		HFN-10(10A)			HFN-15(15A)		HFN-30(30A)		HFN-40(40A)
MC		11A / 240V (GM□-9)			18A / 240V (GM□-18)		32A / 240V (GM□-32)		50A / 240V (GM□-50)
Wire (Note1)	L1,L2 ,L3, PO,PI ,N,B+ ,B,BI, U,V, W	AWG14(2.5 mm <sup>2</sup> )			AWG14(2.5 mm <sup>2</sup> )		AWG12(4.0 mm <sup>2</sup> )		AWG10 (6.0 mm <sup>2</sup> )
	C1, C2	AWG14(2.5 mm <sup>2</sup> )			AWG14(2.5 mm <sup>2</sup> )		AWG14(2.5 mm <sup>2</sup> )		AWG14(2.5 mm <sup>2</sup> )
Crimp terminal		UA-F1510, SEOIL (10mm Strip & Twist)			UA-F2010, SEOIL (10mm Strip & Twist)		UA-F4010, SEOIL (10mm Strip & Twist)		GP110028 KET
Regenerative resistor (Default)		50 W 100 Ω			100 W 40 Ω		150 W 13 Ω		120[W] 6.8Ω
Connector (L1,L2..IV,W)		<ul style="list-style-type: none"> <li>• BLF 5.08/03/180F SN BK BX</li> <li>• BLF 5.08/11/180F SN BK BX</li> </ul>					<ul style="list-style-type: none"> <li>• BLZ7.62HP/03/180LR SN BK BX SO</li> <li>• BLZ7.62HP/11/180LR SN BK BX SO</li> </ul>		

Note1) Use 600V-PVC Insulated wire for wiring.

Use approved UL wire (Temp. 75°C or above) for UL(CSA) Regulation.

Use approved wire for any other regulations.

Use equivalent or above components compare to components above for any special applications.

**(L7NA004B or below)**

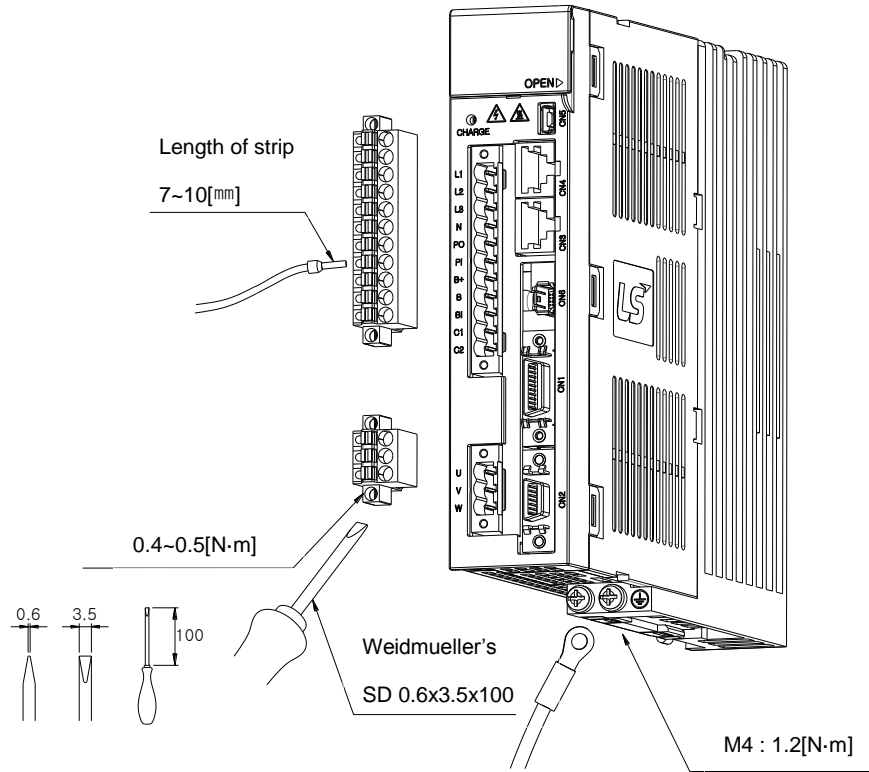

**(L7NA008B ~ L7NA010B)**

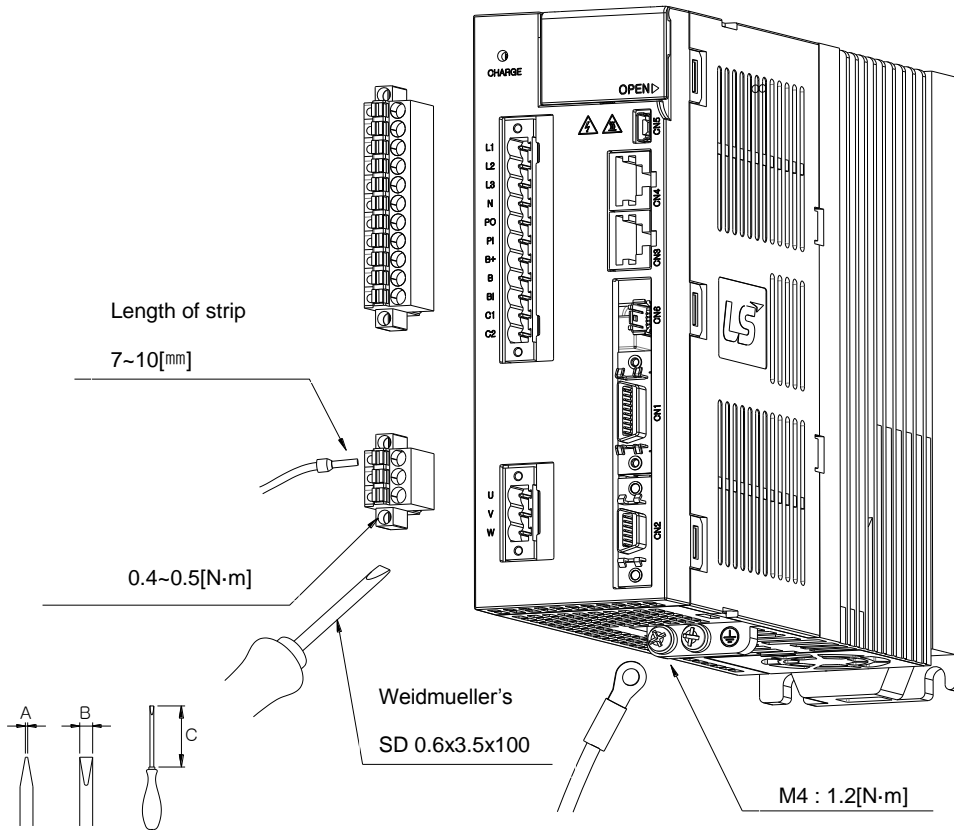

**(L7NA020B ~ L7NA035B)**

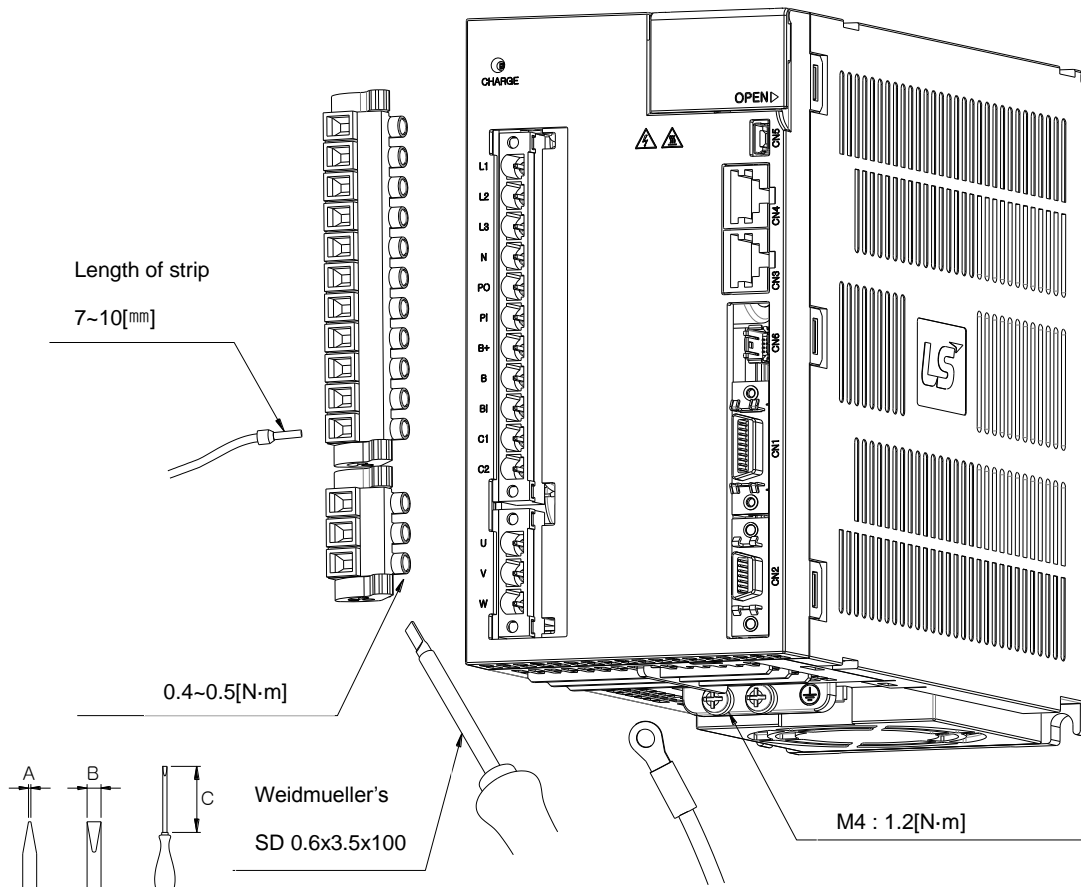

- 1) Refer to the drawings above for wiring with BLF 5.08 or BLZ 7.62HP Series connector.
- 2) Insert wire into wire-hole when upper screw is untightened and then, use appropriate (-) shaped screwdriver with 0.4 ~ 0.5[N.m] torque to make tight completely.
- 3) Cut by vibration, malfunction or fire by short could be occurred if torque of screwing was not enough.
- 4) Make tight completely by using hooks both sides when connectors are attached to servo drive after wiring.
- 5) FG screw which is located the bottom of servo drive has to be M4 and put on the FG screw with 1.2[N.m] torque.
- 6) Malfunction of drive could be occurred if torque of screwing was not enough.
- 7) Recommended (-)-shaped screwdriver: Weidmueller's SD 0.6x3.5x100.

**(L7NA050B)**

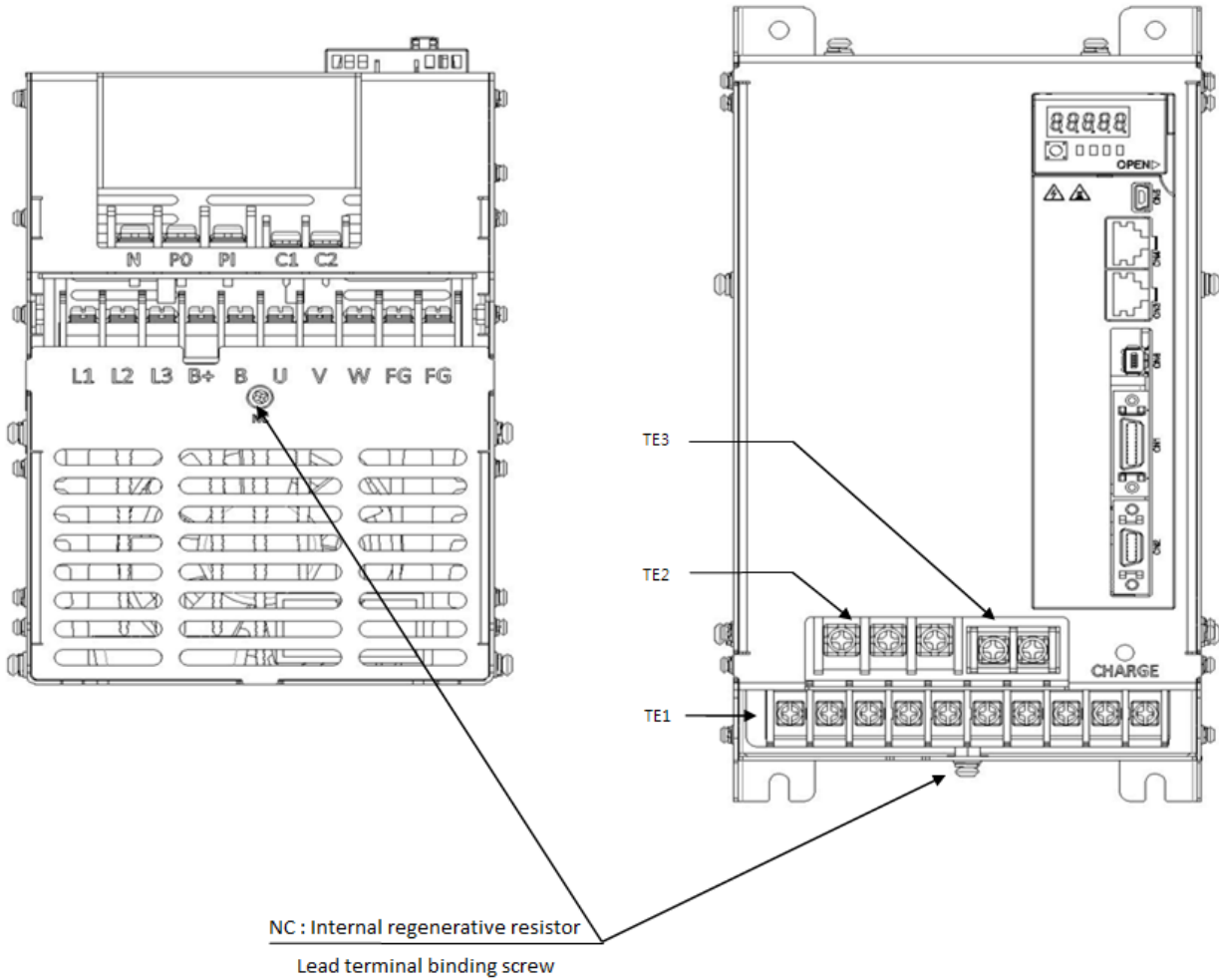

TB1									
L1	L2	L3	B+	B	U	V	W	FG	FG
TB2									
N	PO	P1							
TB3									
C1	C2								

0- Malfunction of drive could be occurred if torque of screwing was not enough.

## 3.3 Timing Diagram

### 3.3.1 Timing Diagram During Power Input

For the L7N Series, connect single-phase power to the C1 and C2 terminals to supply power to the control circuit, and three-phase power to L1, L2, and L3 to supply power to the main circuit.

The servo signal becomes Ready after the maximum period of 120 ms that is required to reset the device elapses. If you change the signal to ON, the servo operates in 40 ms.

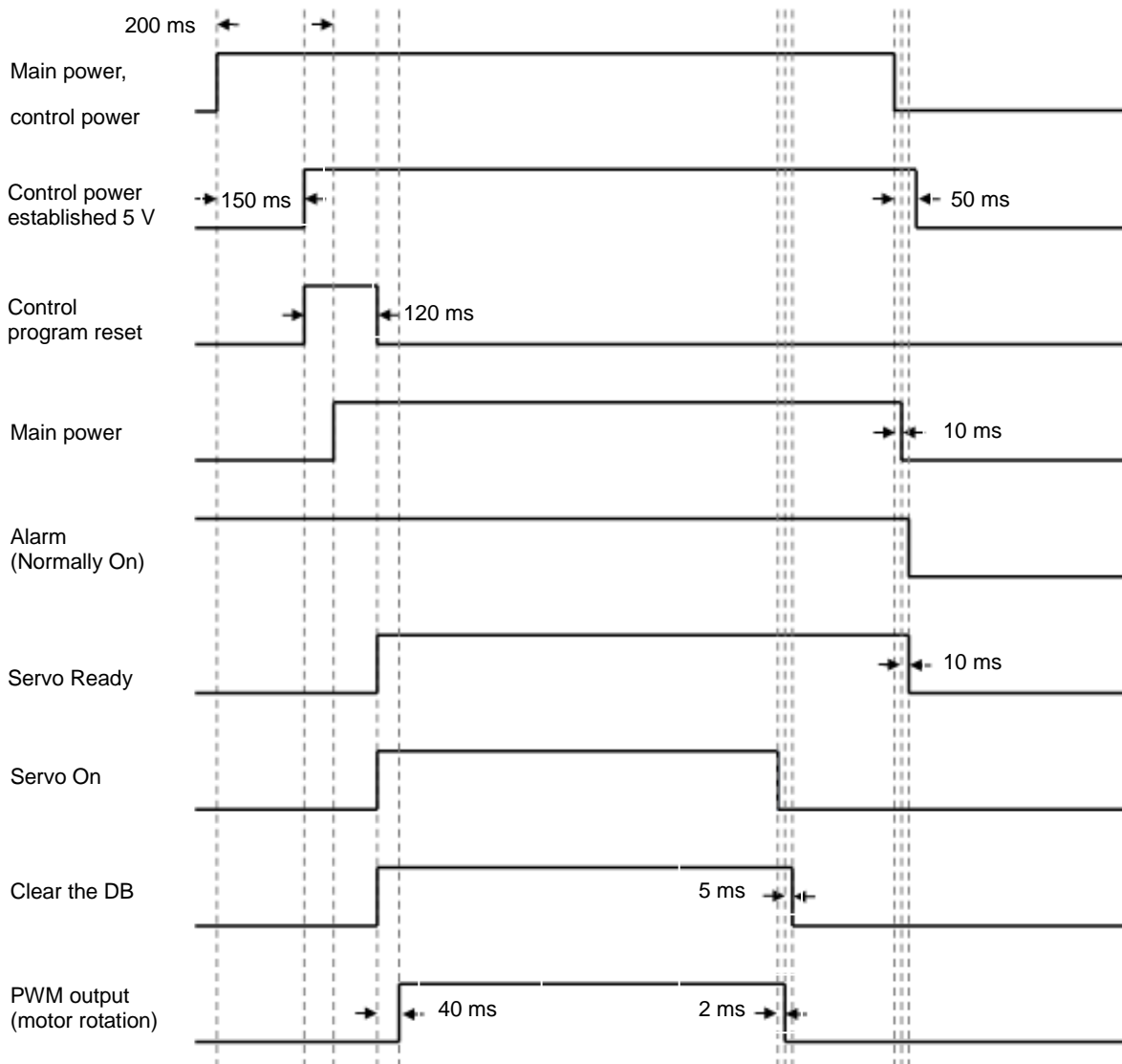

**Note 1)** The Servo Ready turns on after the main power is established and the control program is reset.

**Note 2)** Servo On begins after the Servo Ready is on and the EtherCAT communication and the servo are synchronized.

### 3.3.2 Timing Diagram During an Alarm Trigger

When an alarm is triggered in the servo drive, it blocks the PWM and stops the motor.

**⚠ Caution**

- Reset the alarm after solving the problem that triggered the alarm and after changing the command signal (Servo On) to Off.

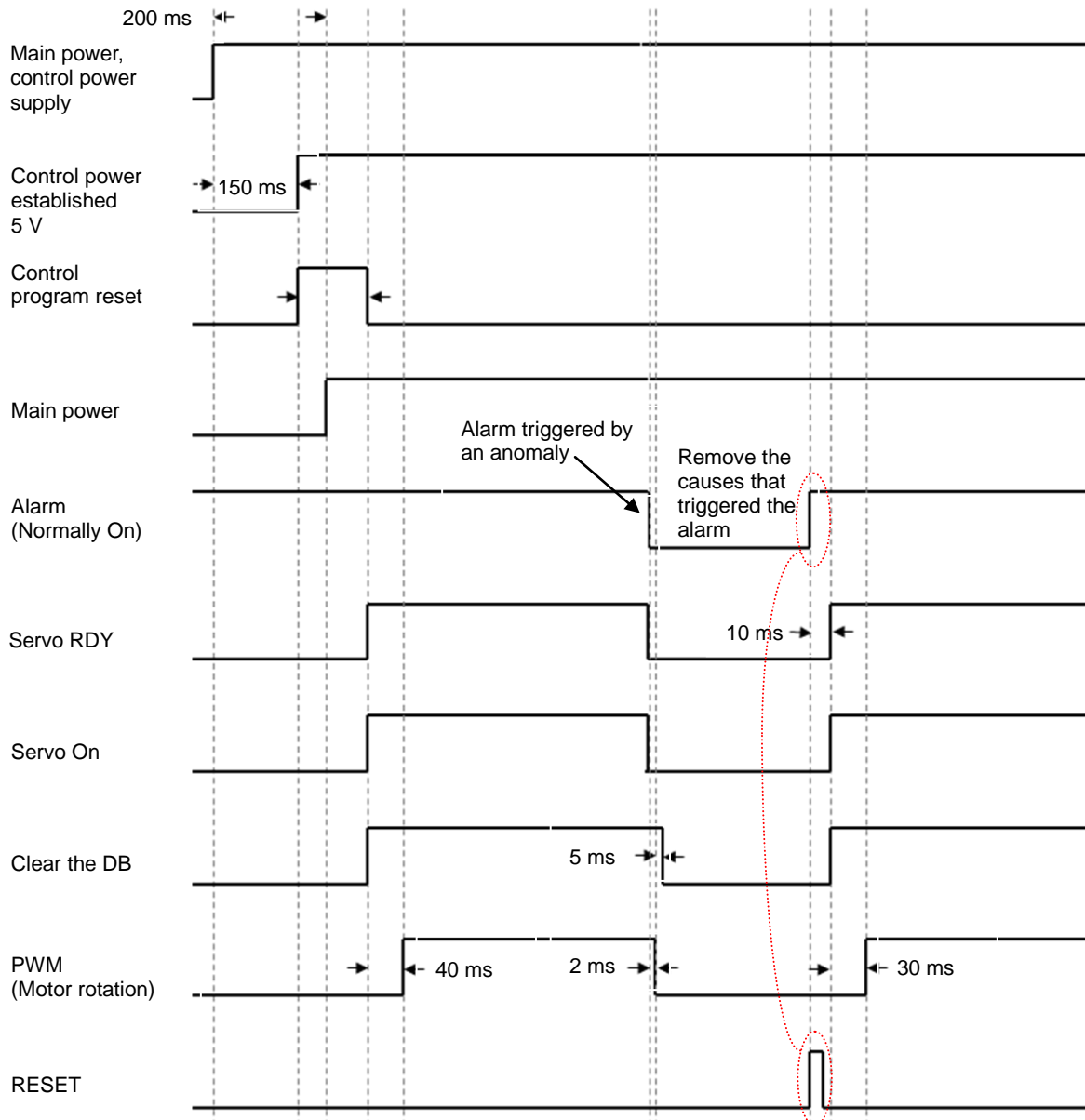

## 3.4 Wiring the Control Signals

### 3.4.1 The Contact Input Signal

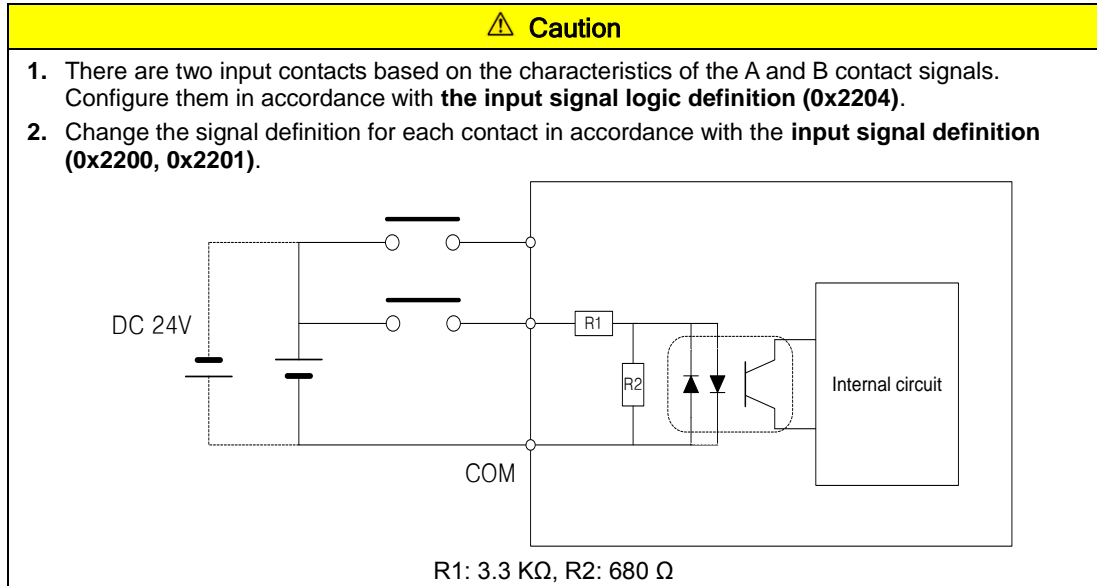

### 3.4.2 The Contact Output Signal

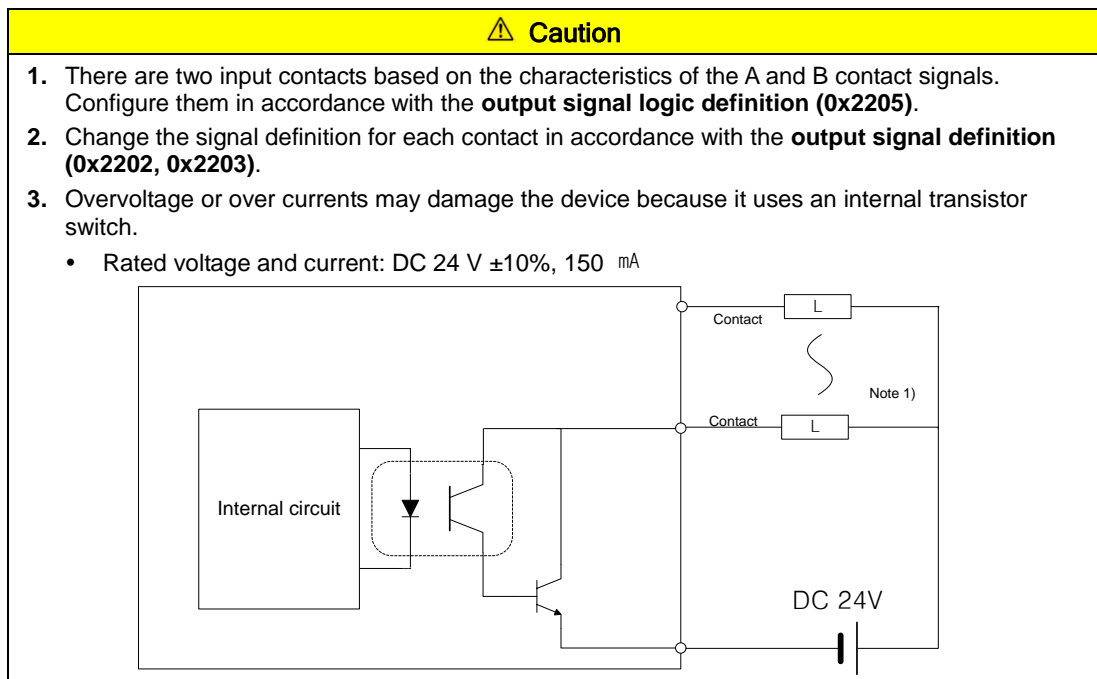

**Note 1)** The alarm and READY output signals are separate in the GND24 terminal.



### 3.5 Connecting Serial Encoder Signals (CN2)

#### 3.5.1 APCS-E□□□CS Cable

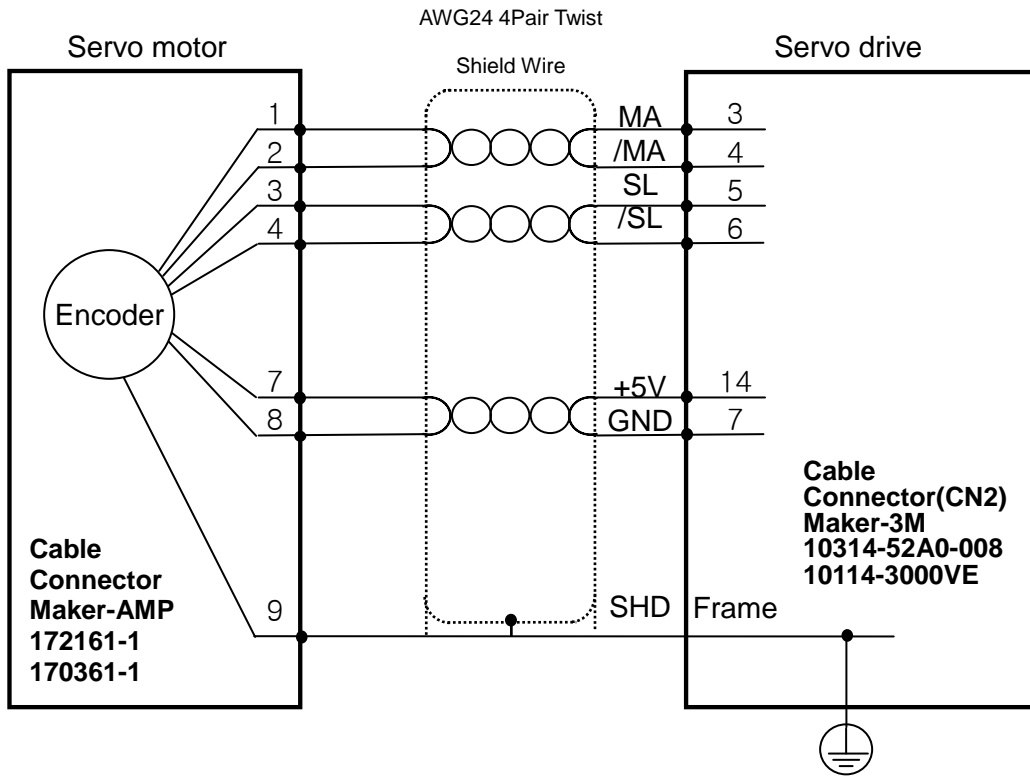

#### 3.5.2 APCS-E□□□DS Cable

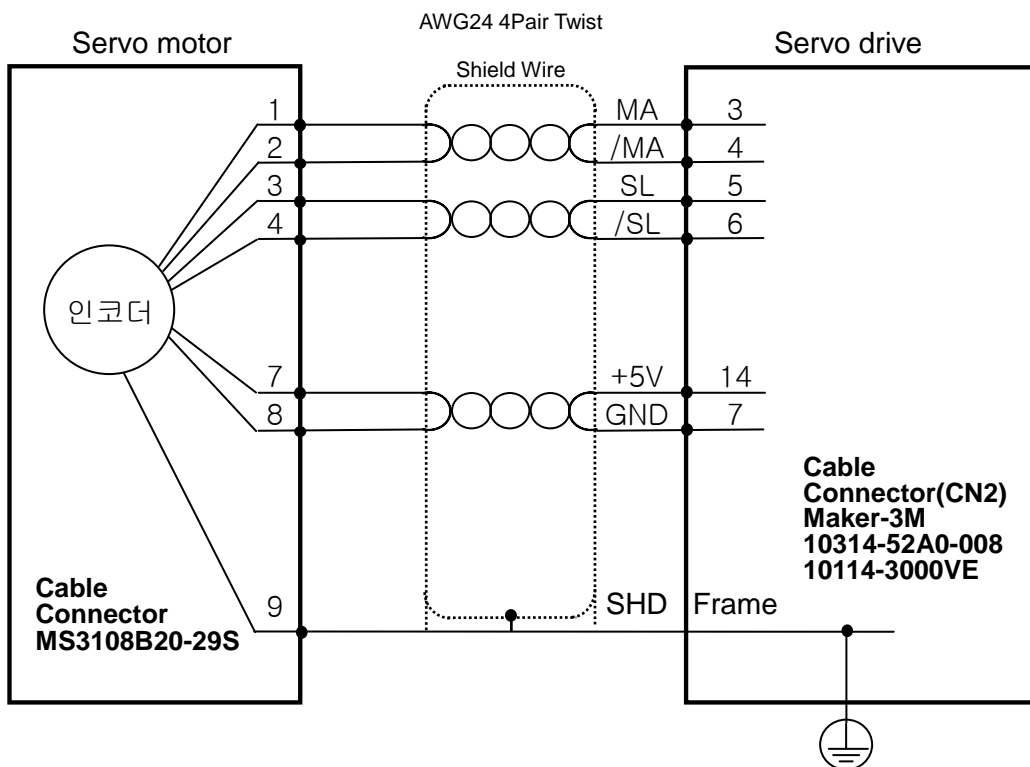

### 3.5.3 APCS-E□□□ES Cable

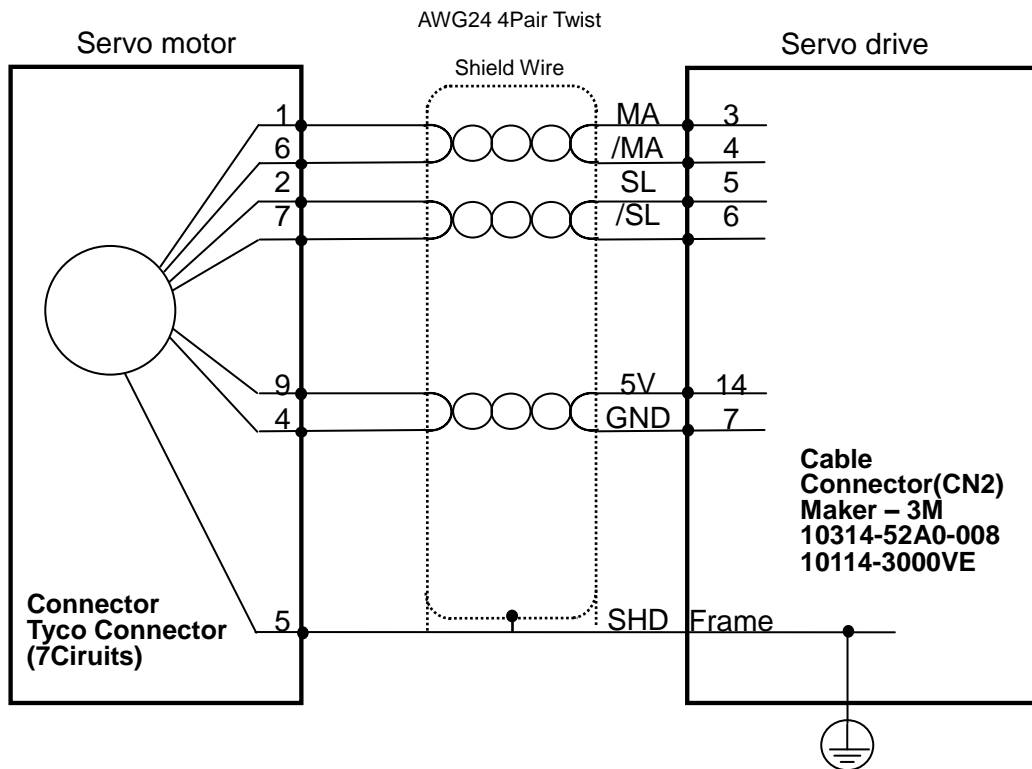

## 3.6 Connecting Multi-turn Encoder Signals (CN2)

### 3.6.1 APCS-E□□□CS1 Cable

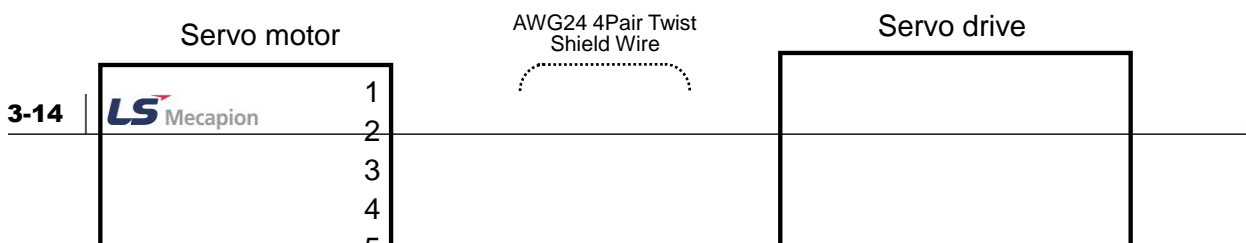

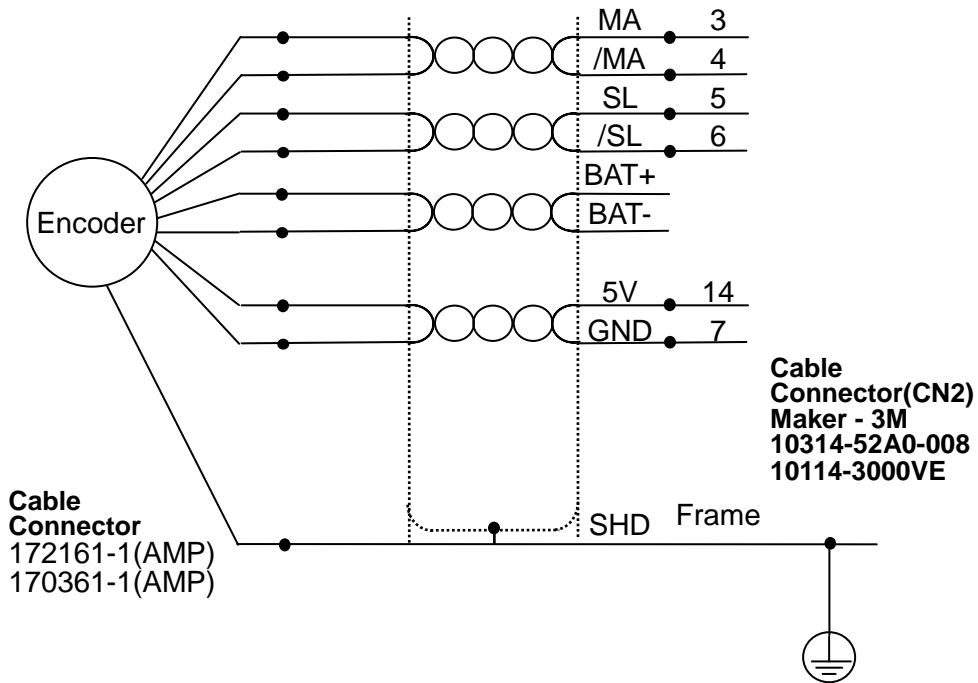

### 3.6.2 APCS-E□□□DS1 Cable

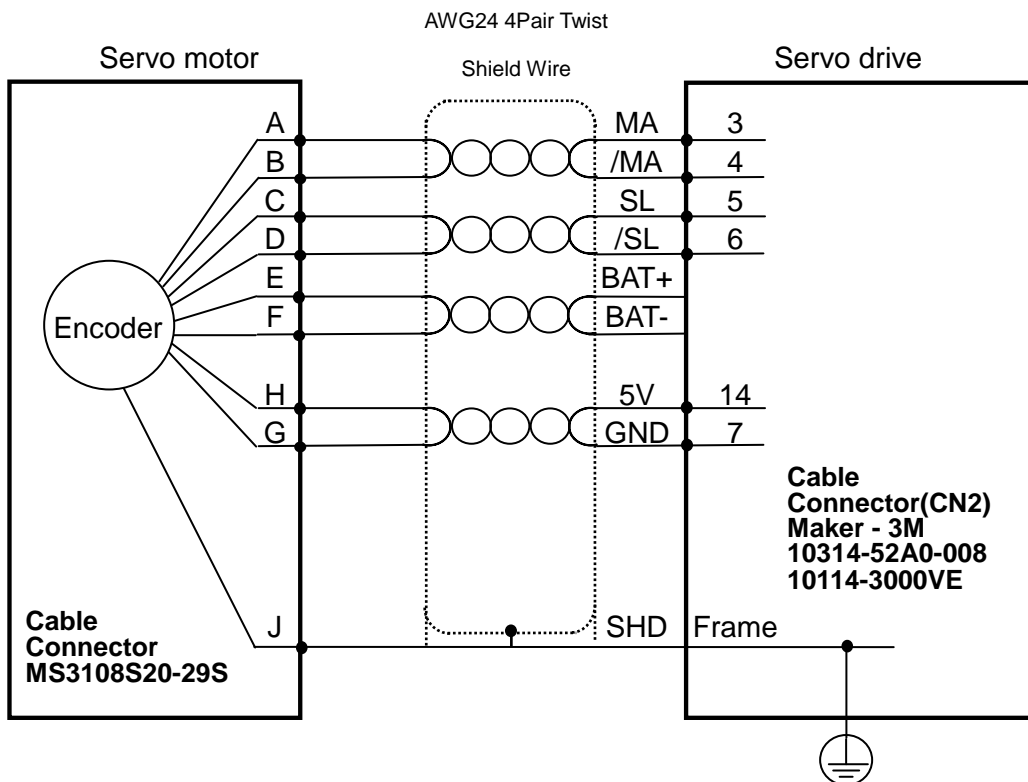

### 3.6.3 APCS-E□□□ES1 Cable

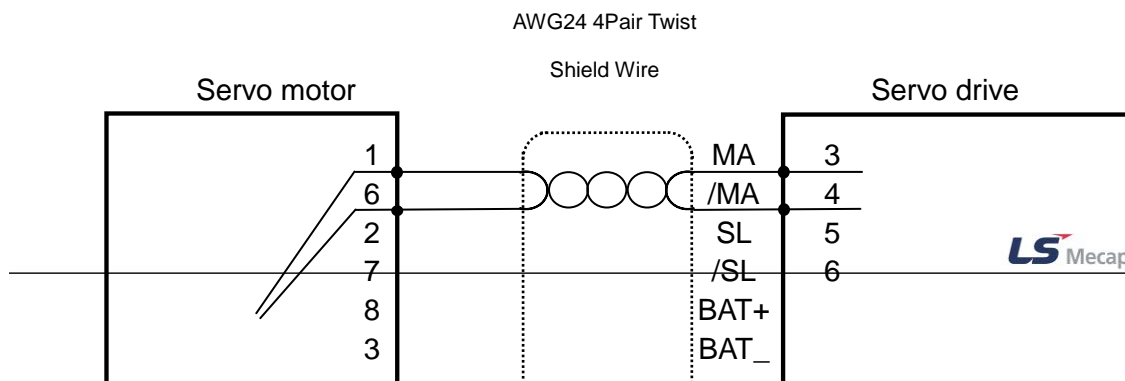

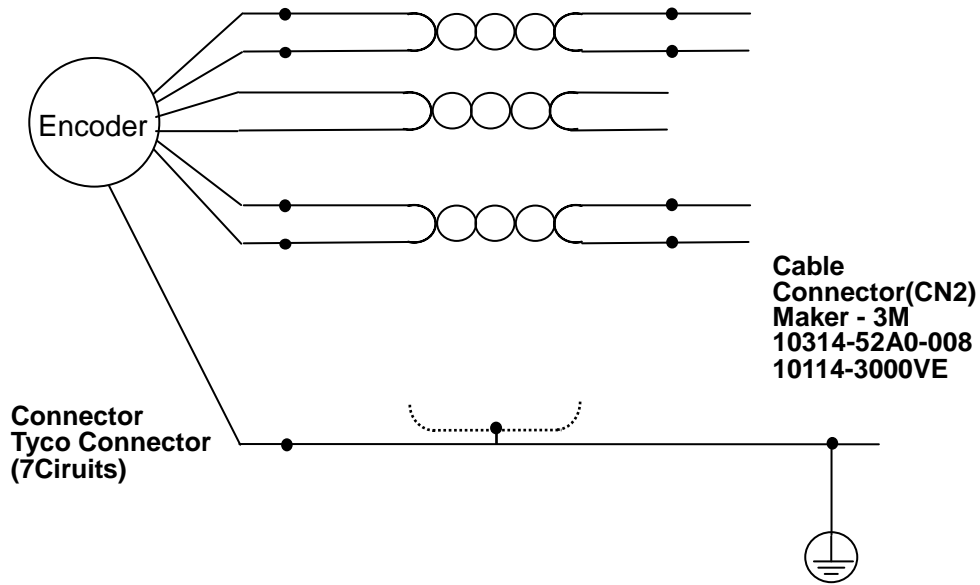

### 3.7 Connecting the Input/Output Signals

#### 3.7.1 The Names and Functions of the Input Signals (CN1)

Pin Number	Name	Details	Function
7	/N-OT	Reverse (CW) rotation prohibited	The actuator stops the servo motor to prevent it from moving beyond the motion range.
8	/P-OT	Forward (CCW) rotation prohibited	
11	HOME	Origin sensor	Connects the origin sensor to return to the

Pin Number	Name	Details	Function
			origin.
12	ALMRST	Alarm reset	Deactivates the servo alarm.
13	PCON	P control action	When the contact is on, the speed control loop transfers the mode from PI control to P control.
14	GAIN2	Transfer of the gain 1 and gain 2	When gain 2 contact is ON, it transfers from gain 1 to gain 2.
9 <sup>Note 1)</sup>	/PROBE1	Touch probe 1	The probe signal to rapidly store the position value.
10 <sup>Note 1)</sup>	/PROBE2	Touch probe 2	

Note 1) You cannot map touch probe signals.

### 3.7.2 The Names and Functions of the Output Signals (CN1)

Pin Number	Name	Details	Function
1	BRAKE+	Brake	Outputs signals to control the brake when the servo is turned on or off.
2	BRAKE-		
3	ALARM+	Alarm	Outputs a signal when an alarm occurs.
4	ALARM-		
17	/READY+	Servo Ready	This signal is output when the main power is established and the preparations for servo operation are complete.
18	/READY-		
19	/ZSPD+	Zero speed reached	Outputs a signal when the current speed drops below the zero speed.
20	/ZSPD-		
Allocated	INPOS	Location reached	Outputs a signal when the device reaches the specified location.
Allocated	INSPD	Speed reached	Outputs a signal when the device reaches the specified speed.
Allocated	WARN	Warning	Outputs warning signals.

### 3.7.3 Layout of the Input/Output Signal Connectors

2	BREAK-	Brake output-	1	BREAK+	Brake output+	12	ALMRST	Alarm reset	11	HOME	Origin sensor
4	ALRAM-	Alarm output-	3	ALRAM+	Alarm output+	14	GAIN2	Transfer of gains 1 and 2	13	PCON	P control action
6	+24V IN	External power input	5	NC	-	16	NC	-	15	NC	-
8	/P-OT	Forward rotation prohibited	7	/N-OT	Reverse rotation prohibited	18	/READY-	Servo ready -	17	/READY+	Servo ready +
10	/PROBE2	Touch probe input 2	9	/PROBE1	Touch probe input 1	20	/ZSPD-	Zero speed achieved-	19	/ZSPD+	Zero speed achieved+

### 3.7.4 The Names and Functions of Safety Function Signals (CN6)

Pin Number	Name	function
3	/HWBB1-	For hard-wired base block inputs Performs a base block (block torque) on signal off.
4	/HWBB1+	
5	/HWBB2+	
6	/HWBB2-	
7	EDM+	Outputs the pilot circuit status.
8	EDM-	

### 3.7.5 The Connector Layout of Safety Function Signals (CN6)

8	EDM-	Pilot circuit state output-	6	/HWBB2+	Hard-wired base block signal input 2+	4	/HWBB1+	Hard-wired base block signal input 1+	2	NC	Note 1)
7	EDM+	Pilot circuit state output+	5	/HWBB2-	Hard-wired base block signal input 2-	3	/HWBB1-	Hard-wired base block signal input 1-	1	NC	Note 1)

**Note 1)** Never use this on a blank terminal because it is connected to an internal circuit.

### 3.7.6 Operation Method of Safety Function Signals (CN6)

1) How to use L7N STO Plug Dummy



Plug Connector Kit : 2040008-1(TE)

Name of product : APC-CN6J

2) How to use EMG Signal on MAIN

Setting	/HWBB1	/HWBB2	EDM	STO State
1	OFF	OFF	ON	STO
2	ON	OFF	OFF	STO
3	OFF	ON	OFF	STO
4	ON	ON	OFF	Normal State

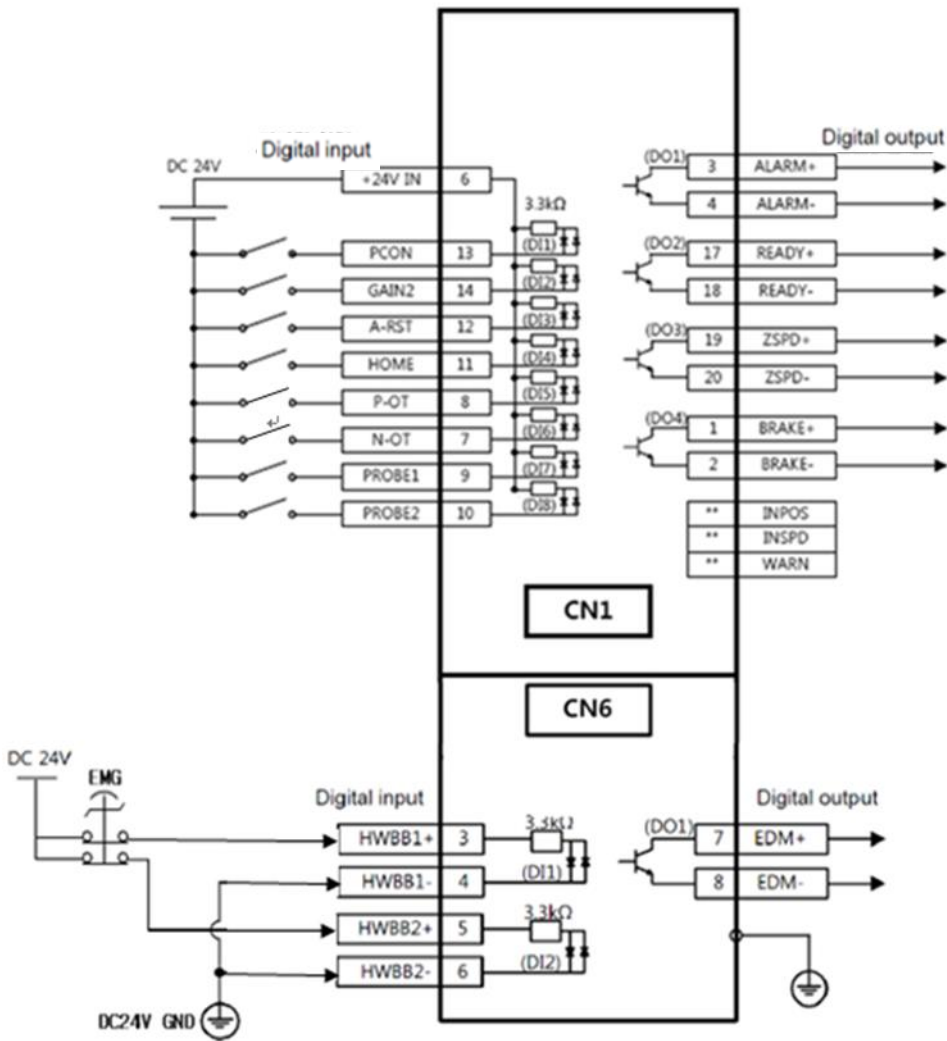

## 3.8 EtherCAT Connection Example

### 3.8.1 Example Connection

The following figure shows the connection between a master and slave using EtherCAT communication.



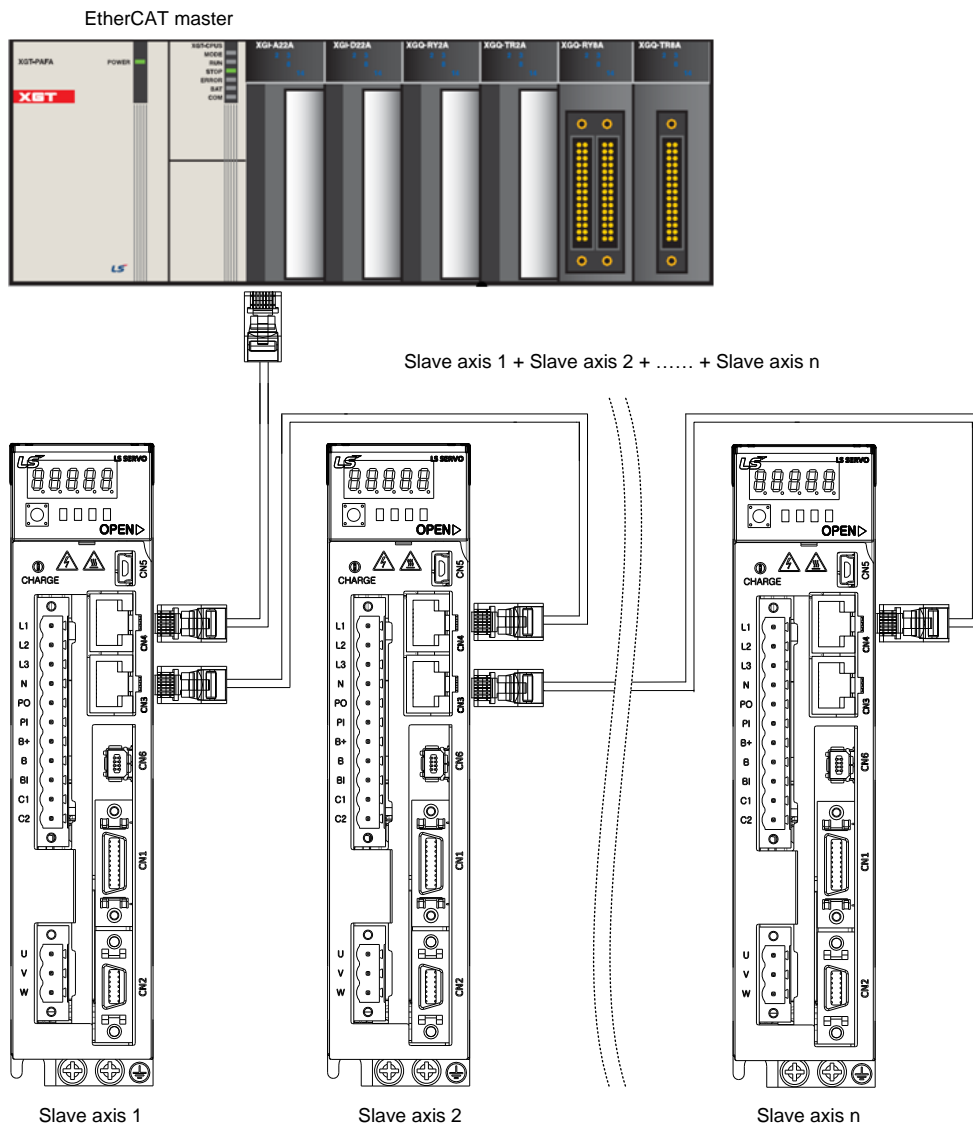

### 3.8.2 EtherCAT Connectors and the Pin Map

The L7N drive uses CN4 and CN3 as I/O Connector for EtherCAT.

Connector	Function
CN4	The EtherCAT input
CN3	The EtherCAT output

Connector		Function
Pin Number	Signal Name	Line color
1	TX/RX0 +	White/Orange
2	TX/RX0 -	Orange
3	TX/RX1+	White/Green
4	TX/RX2 -	Blue
5	TX/RX2 +	White/Blue
6	TX/RX1 -	Green
7	TX/RX3 +	White/Brown
8	TX/RX3 -	Brown
Plate		Shield

**Note 1)** EtherCAT only uses signals from the No. 1, 2, 3, and 6 wires.

**Note 2)** Recommended Connector : STP CAT.5E RJ-45 8P8C

Recommended Cable: CAT.5 STP

### 3.9 Example of connecting to PLC

#### 3.9.1 LSIS – PN8B

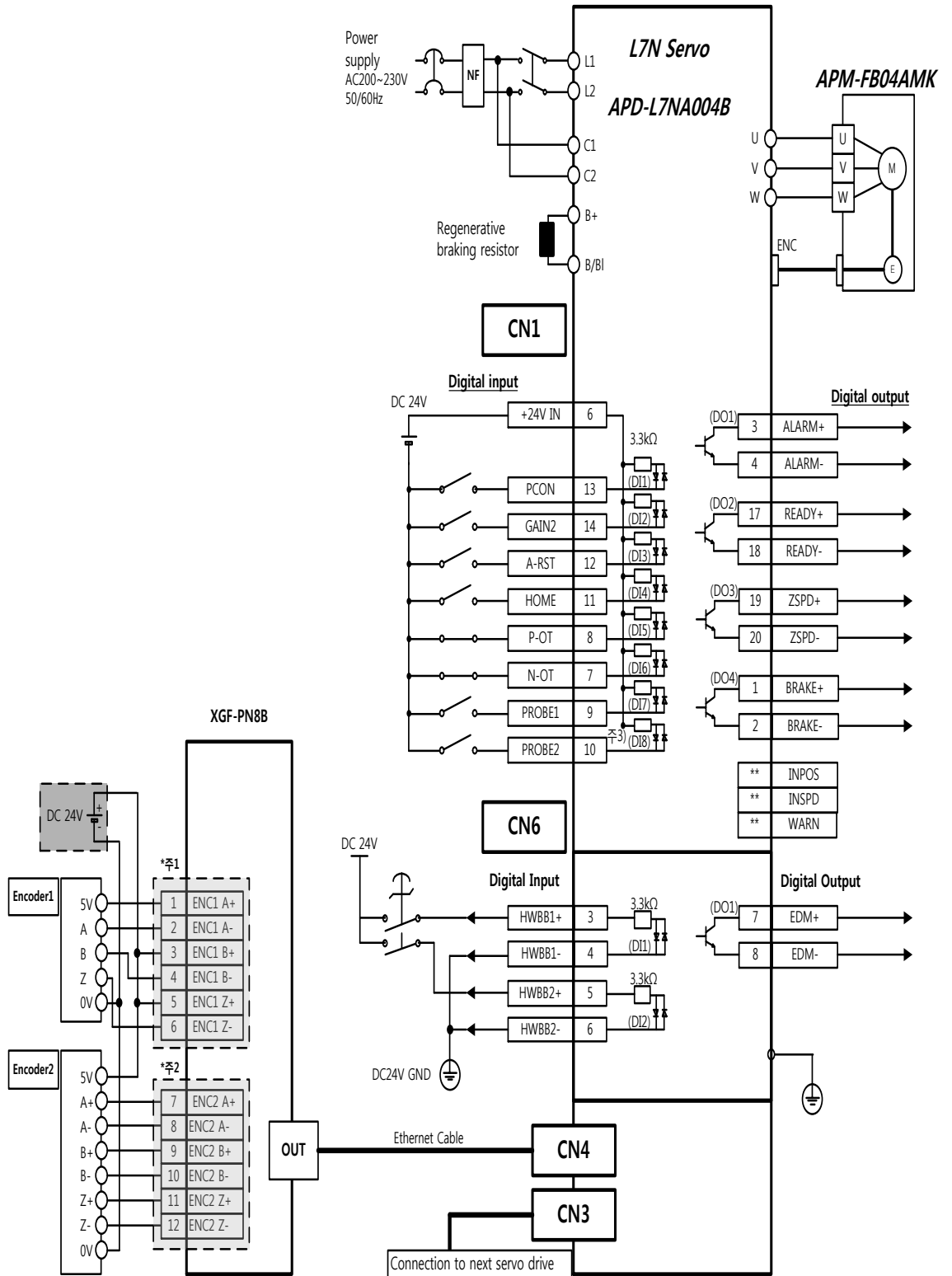

# 4. How to use the Loader

## 4.1 Name and Function of each parts

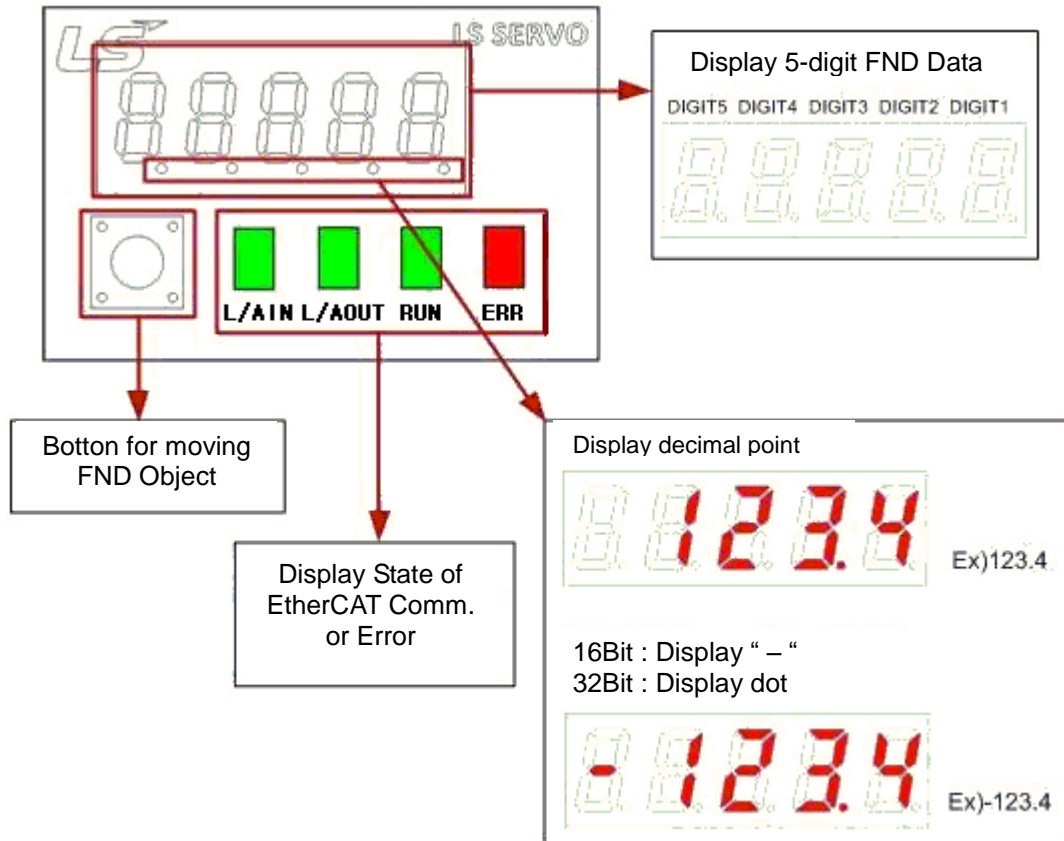

- Refer to 5.3 LED State for more information.

## 4.2 Status Summary Display

### (1) Display Status Summary for CSP Mode

① Example of state of Servo Off in CSP Mode

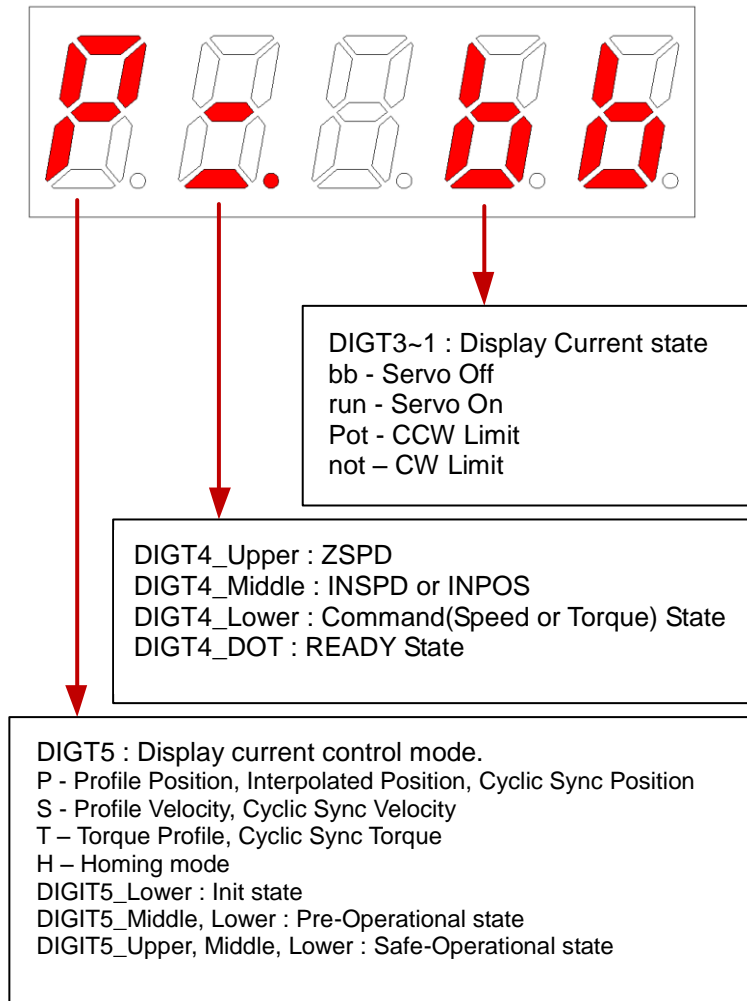

② Example of state of Servo On in CSP Mode

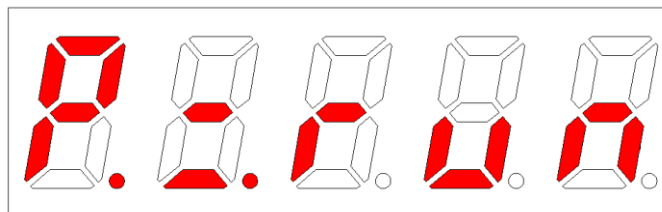

## (2) Chart of status summary for Servo operation.

Refer to chart below for status summary for Servo operation.

Display of DIGT5	Function	Note
	Disconnect STO Connector.	
	Init state.	
	Pre-Op state.	
	Safe-Op state.	
	Servo OFF state in PP, IP or CSP Mode.	
	Servo ON state in PP, IP or CSP Mode.	
	CCW Limit state in PP, IP or CSP Mode.	
	CW Limit state in PP, IP or CSP Mode.	
	Servo OFF state in PV or CSV Mode.	
	Servo ON state in PV or CSV Mode.	
	CCW Limit state in PV or CSV Mode.	
	CW Limit state in PV or CSV Mode.	
	Servo OFF state in TQ or CST Mode.	
	Servo ON state in TQ or CST Mode.	
	CCW Limit state in TQ or CST Mode.	
	CW Limit state in TQ or CST Mode.	
	Servo OFF state in Homing Mode.	
	Servo ON state in Homing Mode.	
	CCW Limit state in Homing Mode.	
	CW Limit state in Homing Mode.	

## 4.3 Display FND Output Object

### (1) How to use the button on loader

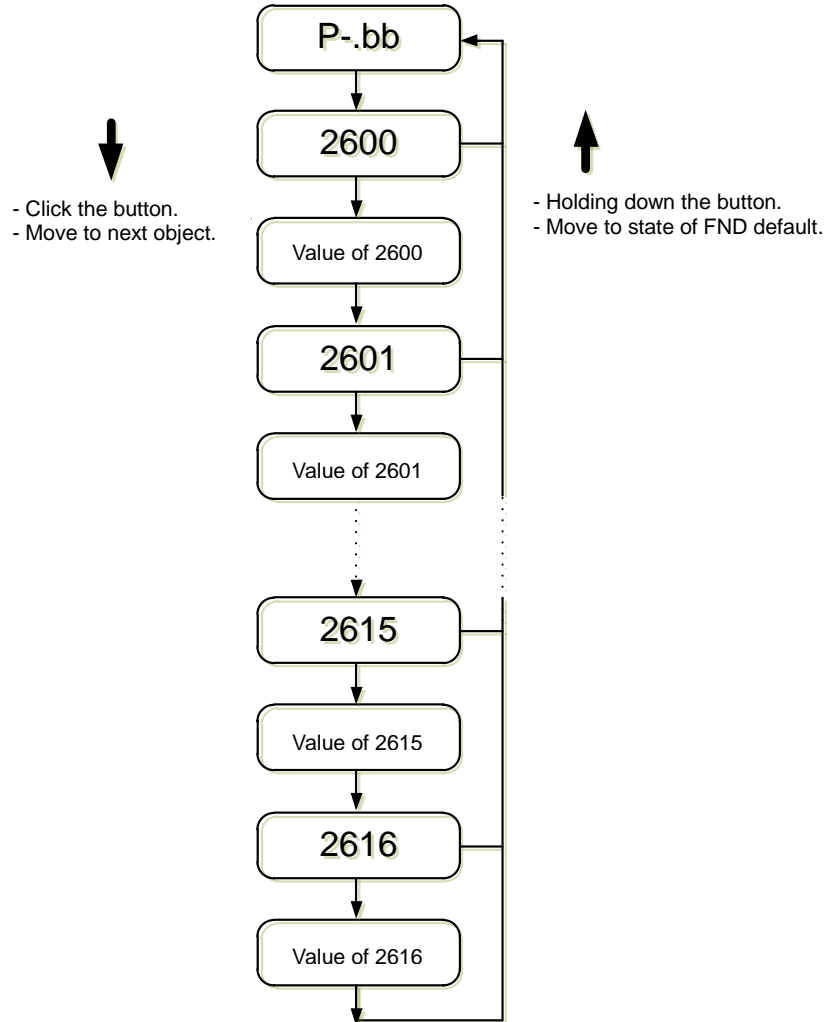

- When clicking the button, display of FND will move to next object and display value of that object.
- If holding down the button while number of object is displayed, it will move to state of FND default.(ex : P-bb, Servo OFF state in Position control Mode)
- Object address which is displayed on FND is from 2600 up to 2616. Those data cannot be modified by button.

## 5. EtherCAT Communication

EtherCAT stands for Ethernet for Control Automation Technology. It is a communication method for masters and slaves which uses Real-Time Ethernet, developed by the German company BECKHOFF and managed by the EtherCAT Technology Group (ETG).

The basic concept of the EtherCAT communication is that, when a DataFrame sent from a master passes through a slave, the slave inputs the received data to the DataFrame as soon as it receives the data.

EtherCAT uses a standard Ethernet frame compliant with IEEE802.3.

Since it is based on a 100BASE-TX Ethernet, cable lengths of up to 100 meters are possible and the maximum number of connected slaves is 65,535, so it is possible to configure a nearly unlimited network size. In addition to this, when using a separate Ethernet switch, you can interconnect it to common TCP/IP.

### 5.1 The Structure of CANopen over EtherCAT

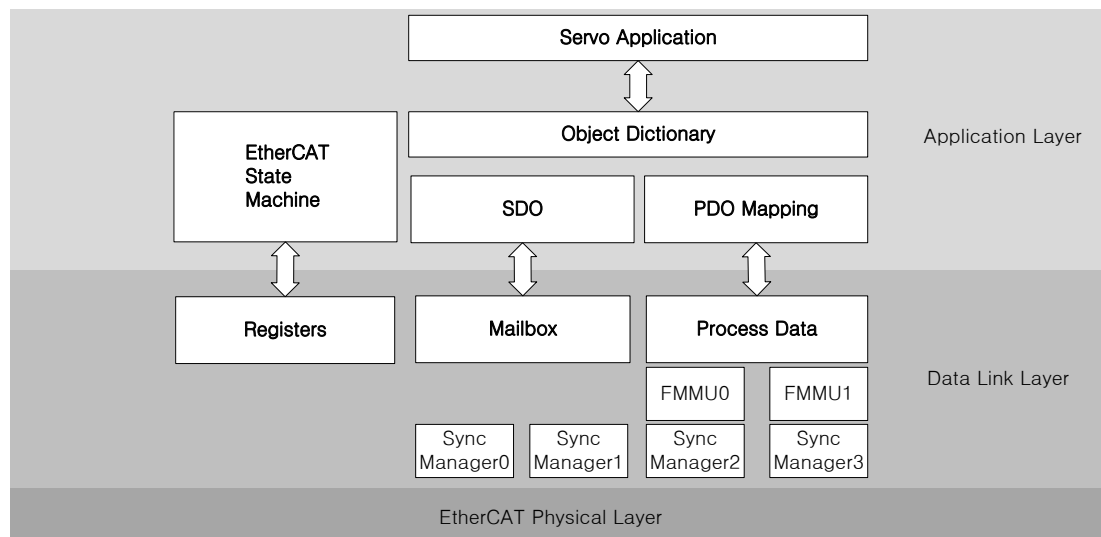

The L7N drive uses a CiA 402 drive profile. The Object Dictionary in the application layer includes application data and PDO mapping information from the process data interface and application data.

The Process Data Object (PDO) consists of an Object Dictionary that can be mapped to the PDO, and the content of the process data is defined by PDO mapping.

The process data communication is able to periodically read and write the PDO. Mailbox communication can aperiodically read and write all of the Object Dictionaries.



## 5.2 The EtherCAT State Machine

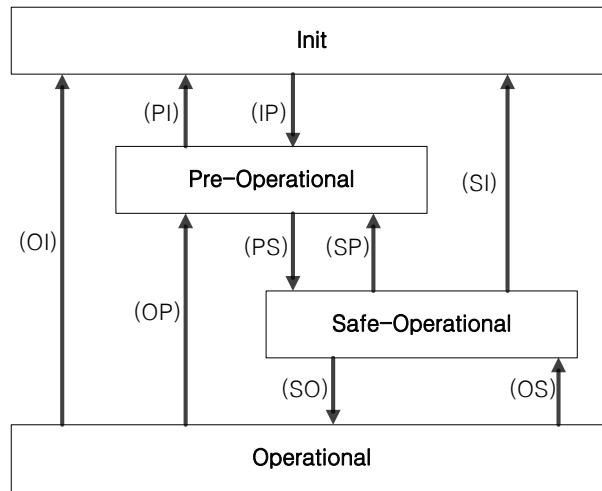

State	Details
Init	Resets a device. Unable to perform mailbox or process data communication.
Pre-Operational	Able to perform mailbox communication.
Safe-Operational	Able to read the PDO input data (TxPDO). Unable to receive PDO output data (RxPDO).
Operational	Performs periodical I/O communication and it is possible to process PDO output data (RxPDO).
Transition State	Details
IP	Begins mailbox communication.
PI	Stops mailbox communication.
PS	Begins input data updates.
SP	Stops input data updates.
SO	Begins output data updates.
OS	Stops output data updates.
OP	Stops input/output data updates.
SI	Stops input data updates and mailbox communication.
OI	Stops both input/output data updates and mailbox communication.

## 5.3 LED State

The LEDs on the operating panel of the L7N drive indicates EtherCAT communication and error statuses, as shown in the following figure.

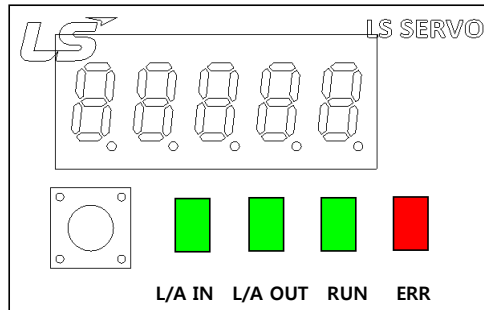

### ■ The L/A IN and L/A OUT (Link Activity) LEDs

The L/A IN LED and L/A OUT LEDs indicate the status of the CN4 and CN3 communication ports respectively. The following table outlines what each LED state indicates.

Link/Activity LED	Description
Off	Not connected for communication.
Flickering	Connected, and communication is enabled. 
On	Connected, but communication is disabled.

### ■ RUN LED

Indicates the status of the L7N in the EtherCAT State Machine.

RUN LED	Description
Off	The L7N is in the INIT state.
Blinking	The L7N is in the Pre-Operational state. 
Single Flash	The L7N is in the Safe-Operational state. 
On	The L7N is in the Operational state.

### ■ The ERR (Error) LED

The ERR LED indicates the EtherCAT communication status. The following table outlines what each LED state indicates.

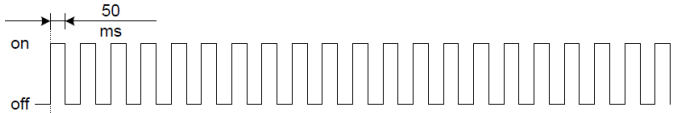
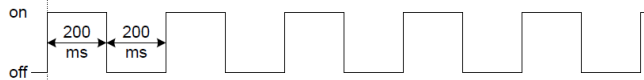
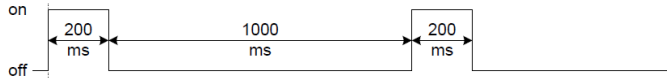
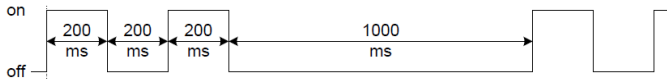
ERROR LED	Description
Off	EtherCAT communication is normal.
Flickering	A booting error occurred. 
Blinking	The object setup command received from the EtherCAT master cannot be performed in the current state. 
Single Flash	The state has changed without a command from the EtherCAT master due to a L7N drive sync error. 
Double Flash	A watchdog error occurred during EtherCAT communication. 
On	A serious problem occurred in the internal communication of the L7N drive.

## 5.4 Data Type

The following table outlines the content and range of the data types used in this manual.

Name	Description	Range
SINT	Signed 8-bit	-128 ~ 127
USINT	Unsigned 8-bit	0 ~ 255
INT	Signed 16-bit	-32768 ~ 32767
UINT	Unsigned 16-bit	0 ~ 65535
DINT	Signed 32-bit	-21247483648 ~ 21247483647
UDINT	Unsigned 32-bit	0 ~ 4294967295
STRING	The String Value	

## 5.5 PDO Mapping

The EtherCAT uses the Process Data Object (PDO) to perform real-time data transfers. There are two types of PDOs: RxPDO receives data transferred from the upper level controller, and TxPDO sends the state from the drive to the upper level controller.

The L7N uses 0x1600 to 0x1603 for RxPDO mapping and 0x1A00 to 0x1A03 for TxPDO mapping. You can map up to 10 objects on each PDO.

The following figure shows an example of PDO mapping.

Index	Sub	Name	Data Type
0x6040	-	Controlword	UINT
0x607A	-	Target Position	DINT

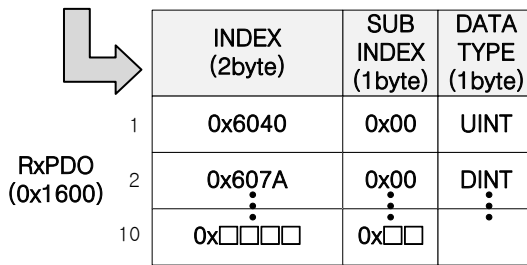

Index	Sub	Name	Data Type
0x6041	-	Statusword	UINT
0x6064	-	Position Actual Value	DINT
0x606C	-	Velocity Actual Value	DINT



The SyncManager can be composed of multiple PDOs. SyncManager PDO Assign Object (RxPDO:0x1C12, TxPDO:0x1C13) indicates the relationship between the SyncManager and the PDO.

The following figure shows the SyncManager PDO mapping.

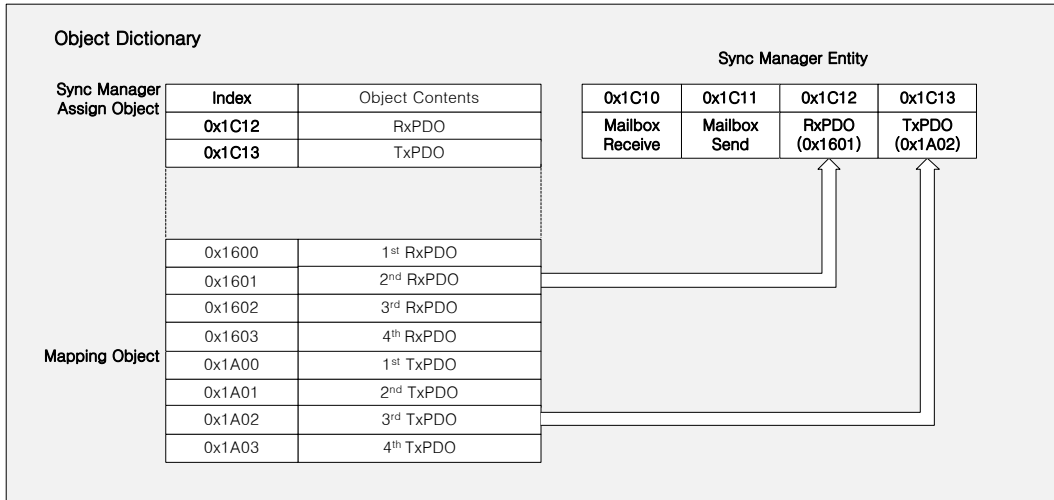

### ■ L7N PDO Mapping

The following tables list the default PDO mapping set in the L7N. These settings are defined in the EtherCAT Slave Information file (XML file).

- 1<sup>st</sup> PDO Mapping

<b>RxPDO</b>	Controlword	Target torque	Target position	Drive mode	Touch probe function					
<b>(0x1600)</b>	(0x6040)	(0x6071)	(0x607A)	(0x6060)	(0x6088)					
<b>TxPDO</b>	Statusword	Actual torque value	Position actual value	Following error actual value	Digital input	Drive mode display	Command speed	Drive speed	Touch probe state	Position value of the forward of
<b>(0x1A00)</b>	(0x6041)	(0x6077)	(0x6064)	(0x60F4)	(0x60FD)	(0x6061)	(0x2601)	(0x2600)	(0x6089)	(0x608A)

- 2<sup>nd</sup> PDO Mapping

<b>RxPDO</b>	Controlword	Target position
<b>(0x1601)</b>	(0x6040)	(0x607A)
<b>TxPDO</b>	Statusword	Position actual value
<b>(0x1A01)</b>	(0x6041)	(0x6064)

- 3<sup>rd</sup> PDO Mapping

<b>RxPDO</b>	Controlword	Target velocity
<b>(0x1602)</b>	(0x6040)	(0x60FF)
<b>TxPDO</b>	Statusword	Position actual value
<b>(0x1A02)</b>	(0x6041)	(0x6064)

- 4<sup>th</sup> PDO Mapping

<b>RxPDO</b>	Controlword	Target torque
<b>(0x1603)</b>	(0x6040)	(0x6071)
<b>TxPDO</b>	Statusword	Position actual value
<b>(0x1A03)</b>	(0x6041)	(0x6064)

## 5.6 Synchronization Using the DC (Distributed Clock)

The Distributed Clock (DC) synchronizes EtherCAT communication. The master and slave share a reference clock (system time) for synchronization, and the slave synchronizes its applications with the Sync0 event generated by the reference clock.

The following synchronization modes exist in the L7N. You can change the mode with the sync control register.

- Free-run mode
 

In free-run mode, the L7N operates each cycle independently from the communication cycle and master cycle.
- DC Synchronous Mode
 

In DC Synchronous mode, the Sync0, event from the EtherCAT master, synchronizes the drive.

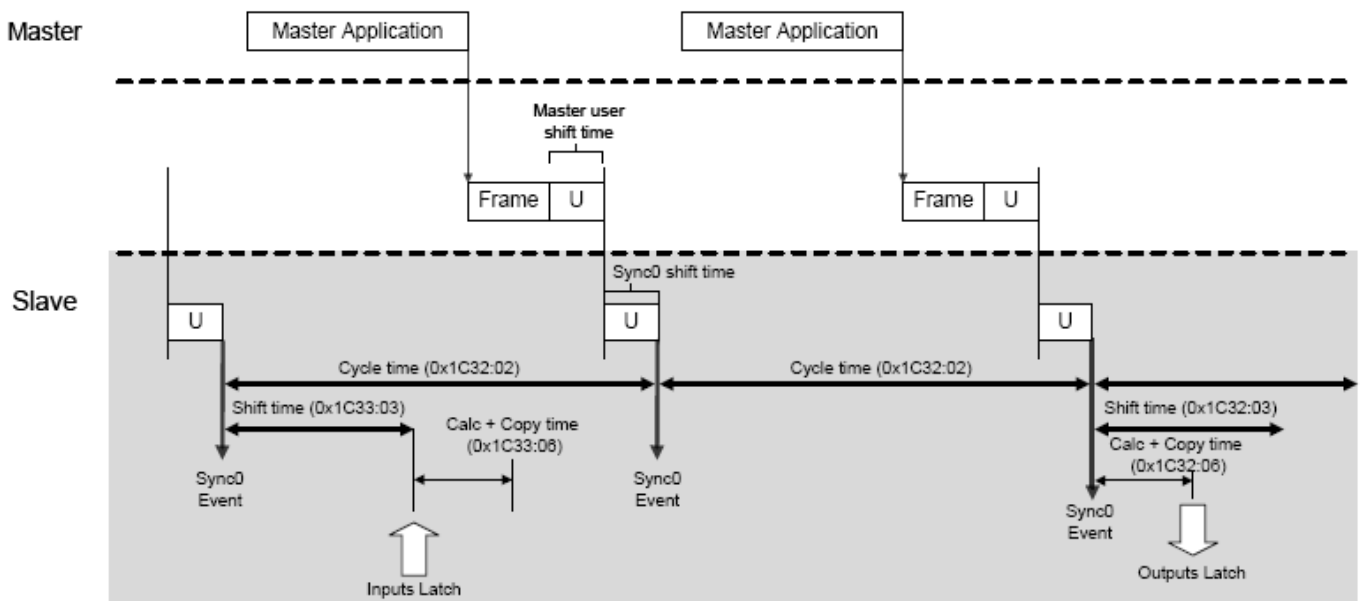

Index 0x1C32		Sync Manager 2 (Process Data Output) Synchronization					
<b>Number of entries</b>							
Sub Index	Initial value	Data Type	Access	PDO Mapping	Setting Range	Change	Unit
0	10	USINT	RO	No	-	-	-
<b>Synchronization modes</b>							
Sub Index	Initial value	Data Type	Access	PDO Mapping	Setting Range	Change	Unit
1	0: Free-Run	UINT	RO	No	-	-	-
<b>Cycle time</b>							
Sub Index	Initial value	Data Type	Access	PDO Mapping	Setting Range	Change	Unit
2	Time between Sync0 events [ns]	UDINT	RO	No	-	-	-
<b>Shift time</b>							
Sub Index	Initial value	Data Type	Access	PDO Mapping	Setting Range	Change	Unit
3	125000 [ns]	UDINT	RO	No	-	-	-
<b>Synchronization modes supported</b>							
Sub Index	Initial value	Data Type	Access	PDO Mapping	Setting Range	Change	Unit
4	Synchronization mode Bit 0 = 1: Free-Run supported Bit 4:2 = 001: DC Sync0 supported Bit 6:5 = 00: No Output Shift supported	UINT	RO	No	-	-	-
<b>Minimum cycle time</b>							
Sub Index	Initial value	Data Type	Access	PDO Mapping	Setting Range	Change	Unit
5	62500 [ns]	UDINT	RO	No	-	-	-
<b>Calc and copy time</b>							
Sub Index	Initial value	Data Type	Access	PDO Mapping	Setting Range	Change	Unit
6	62500 [ns]	UDINT	RO	No	-	-	-

Delay time							
Sub Index	Initial value	Data Type	Access	PDO Mapping	Setting Range	Change	Unit
9	0 [ns]	UDINT	RO	No	-	-	-



Index 0x1C33		Sync Manager 3 (Process Data Input) Synchronization					
<b>Number of entries</b>							
Sub Index	Initial value	Data Type	Access	PDO Mapping	Setting Range	Change	Unit
0	10	USINT	RO	No		-	-
<b>Synchronization modes</b>							
Sub Index	Initial value	Data Type	Access	PDO Mapping	Setting Range	Change	Unit
1	same as 0x1C32:01	UINT	RO	No		-	-
<b>Cycle time</b>							
Sub Index	Initial value	Data Type	Access	PDO Mapping	Setting Range	Change	Unit
2	same as 0x1C32:02	UDINT	RO	No		-	-
<b>Shift time</b>							
Sub Index	Initial value	Data Type	Access	PDO Mapping	Setting Range	Change	Unit
3	125000*n [ns] (n = 1, 2, 3...) Range: 0 to (Sync0 event cycle time – 125000)	UDINT	RO	No		-	-
<b>Synchronization modes supported</b>							
Sub Index	Initial value	Data Type	Access	PDO Mapping	Setting Range	Change	Unit
4	Bit 0 = 1 : Free-Run supported Bit 4:2 = 001 : DC Sync0 supported Bit 6:5 = 01 : Input Shift with local timer supported	UINT	RO	No		-	-
<b>Minimum cycle time</b>							
Sub Index	Initial value	Data Type	Access	PDO Mapping	Setting Range	Change	Unit
5	same as 0x1C32:05	UDINT	RO	No	-	-	-

## 5.7 Emergency Messages

Emergency messages appear as a L7N alarm or a warning passed to the master via mailbox communication. Emergency messages may not be sent in the event of communication failure.

Emergency messages consist of 8-byte data.

Byte	0	1	2	3	4	5	6	7
Details	Emergency error code (0xFF00)		Error register (0x1001)	Reserved	Unique field for each manufacturer			
					L7N alarm code		Reserved	

# 6. CiA402 Drive Profile

## 6.1 The State Machine

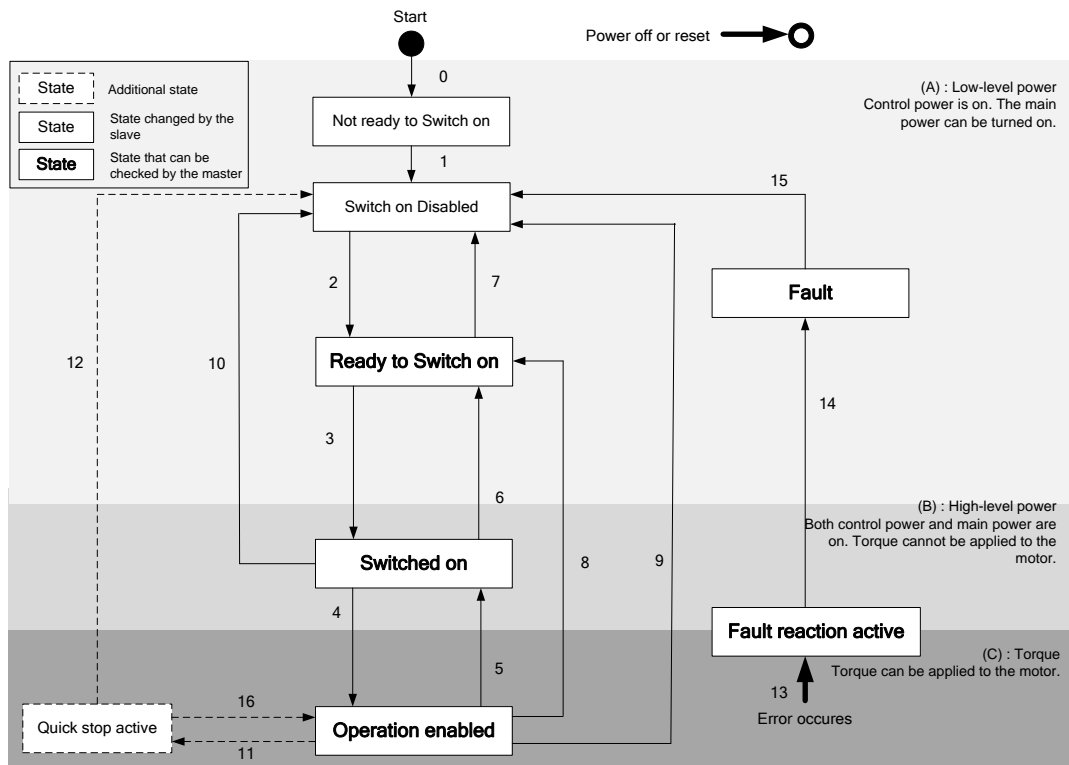

State	Details
Not ready to switch on	Reset is in progress by control power on.
Switch on disabled	Reset is complete. You can set servo parameters. However, you cannot supply main power at this time.
Ready to switch on	Main power may be turned on. You can set servo parameters. Drive function is disabled.
Switched on	Main power is on. You can set servo parameters. Drive function is disabled.
Operation enabled	Unless in a fault state, the drive functions correctly and torque can be applied to the motor. You can also set servo parameters.
Quick Stop active	A quick stop function has been performed. You can set servo parameters.
Fault reaction active	In a Quick Stop or a fault state due to the servo. You can set servo parameters.
Fault	A fault reaction has been processed. Drive function is deactivated. You can set servo parameters.

## ■ State Machine Control Commands

Command	Controlword bits (0x6040)					State Machine Movement
	Bit 7	Bit 3	Bit 2	Bit 1	Bit 0	
Shutdown	0	-	1	1	0	2, 6, 8
Switch on	0	0	1	1	1	3
Switch on + Enable operation	0	1	1	1	1	3 + 4
Disable voltage	0	-	-	0	-	7, 9, 10,12
Quick stop	0	-	0	1	-	7, 10,11
Disable operation	0	0	1	1	1	5
Enable operation	1	1	1	1	1	4, 16
Fault reset	0 → 1	-	-	-	-	15

## ■ Statusword Bit Names (0x6041)

Bit No.	Data Description	Note
0	Ready to switch on	For more information, refer to 7.6 CiA 402 Objects.
1	Switched on	
2	Operation enabled	
3	Fault	
4	Voltage enabled	
5	Quick stop	
6	Switch on disabled	
7	Warning	
8	-	
9	Remote	
10	Target reached	
11	Internal limit active	
12	Operation mode specific	
13		
14	Torque limit active	
15	-	

■ **Related Objects**

Index	Sub	Name	Data Type	Access	PDO Mapping	Units
0x6040	-	Controlword	UNIT	RW	Yes	-
0x6041	-	Statusword	UINT	RO	Yes	-
0x605A	-	Quick Stop option code (Quick Stop Option Code)	INT	RW	No	-
0x605B	-	Shutdown option code (Shutdown Option Code)	INT	RW	No	-
0x605C	-	Disable Operation option code (Disable Operation Option Code)	INT	RW	No	-
0x605D	-	Halt option code (Halt Option Code)	INT	RW	No	-
0x605E	-	FAULT reaction option code (Fault Reaction Option Code)	INT	RW	No	-

## 6.2 Operation Modes

The L7N supports the following operation modes (0x6060):

- Profile Position Mode
- Homing Mode
- Interpolated Position Mode
- Profile Velocity Mode
- Profile Torque Mode
- Cyclic Synchronous Position Mode
- Cyclic Synchronous Velocity Mode
- Cyclic Synchronous Torque Mode

### ■ Related Objects

Index	Sub	Name	Data Type	Access	PDO Mapping	Units
0x6060	-	Drive Mode (Modes of Operation)	SNIT	RW	Yes	-
0x6061	-	Display the operation mode (Modes of Operation Display)	SNIT	RO	Yes	-
0x6502	-	Supported drive modes (Supported Drive Modes)	UDINT	RO	No	-

### ■ Dynamic Conversion of Operation Modes

The 0x6060 object can change the operation mode. The master simultaneously selects an operation mode and changes the related objects. When the master switches to a new operation mode, the L7N instantly switches to that mode.

## 6.3 Position Control Modes

### 6.3.1 Profile Position Mode

Profile Position Mode drives to a target position using the profile speed (0x6081) and profile acceleration (0x6083, 0x6084).

The Profile Position Mode Block Diagram

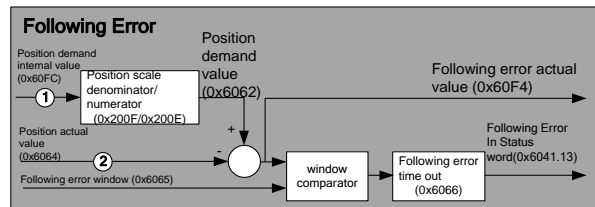
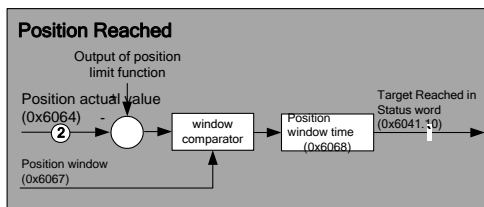
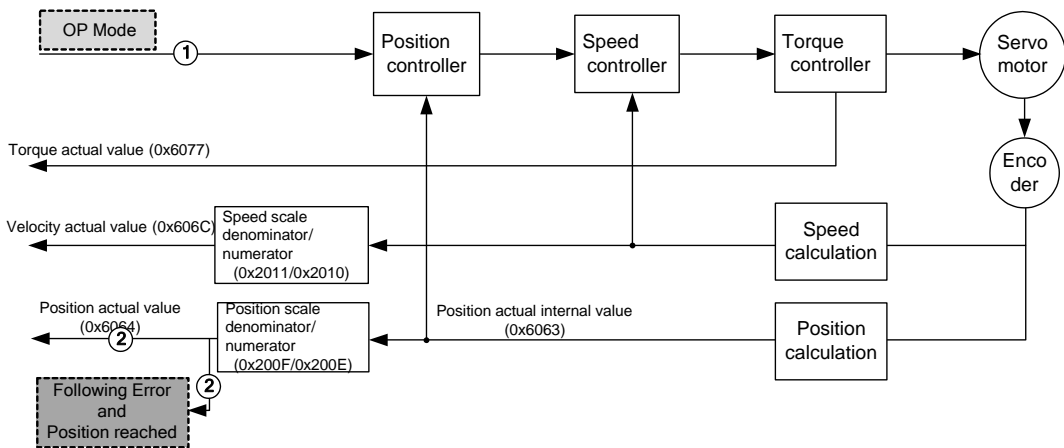
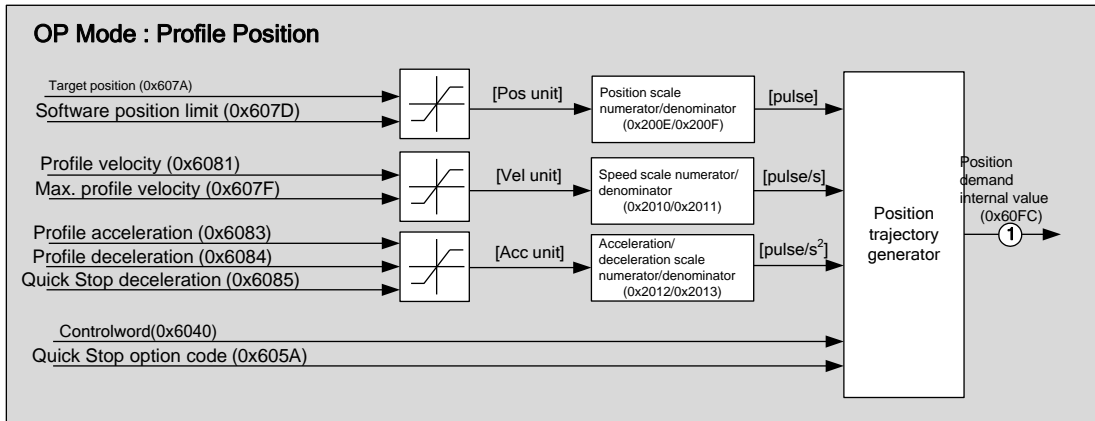

## ■ Related Objects

Index	Sub	Name	Data Type	Access	PDO Mapping	Units
0x6040	-	Controlword	UNIT	RW	Yes	-
0x6041	-	Statusword	UINT	RO	Yes	-
0x607A	-	Target position	DINT	RW	Yes	Pos Units
0x607D	-	Software position limit	-	-	-	-
	0	Number of entries	USINT	RO	No	-
	1	Minimum position limit	DINT	RW	No	Pos Units
	2	Maximum position limit	DINT	RW	No	Pos Units
0x607F	-	Maximum profile velocity	UDINT	RW	No	Vel Units
0x6081	-	Profile velocity	UDINT	RW	Yes	Vel Units
0x6083	-	Profile acceleration	UDINT	RW	Yes	Acc units
0x6084	-	Profile deceleration	UDINT	RW	Yes	Acc units
0x6085	-	Quick Stop deceleration	UDINT	RW	Yes	Acc units

You can use the following three position commands in Profile Position Mode:

- Single set point

After reaching the target position, the drive sends a completion signal to the master and receives a new command.

- Change immediately

After receiving a new position command while driving to the target position, it drives to the new position regardless of the existing target.

- Set of Set point

After receiving a new position command while driving to the target position, it subsequently drives to the new target after reaching the existing target. This mode retains the previous velocity.

The two methods mentioned above are controlled by the New setpoint bit (Controlword, 0x6040.4), the Change set immediately bit (Controlword, 0x6040.5), and the Change setpoint bit (Controlword, 0x6040.9).



### ■ The single setpoint procedure

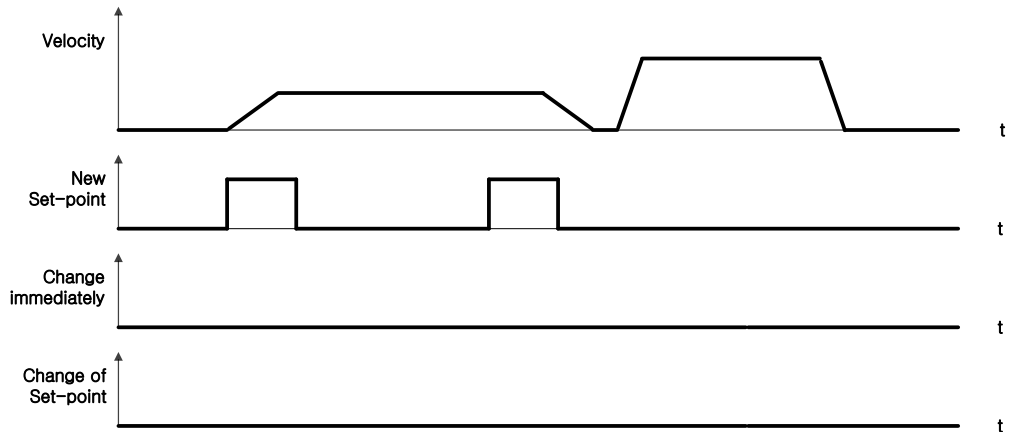

1. Specify the target position (0x607A).
2. Set the New setpoint bit to 1 and the Change set immediately bit to 0 to request the position operation.
3. The drive notifies the operator of its arrival at the target position with the Target reached bit (Statusword, 0x6041.10). The drive can stay where it is or perform a new position operation if it receives the New set point bit.

### ■ The change immediately procedure

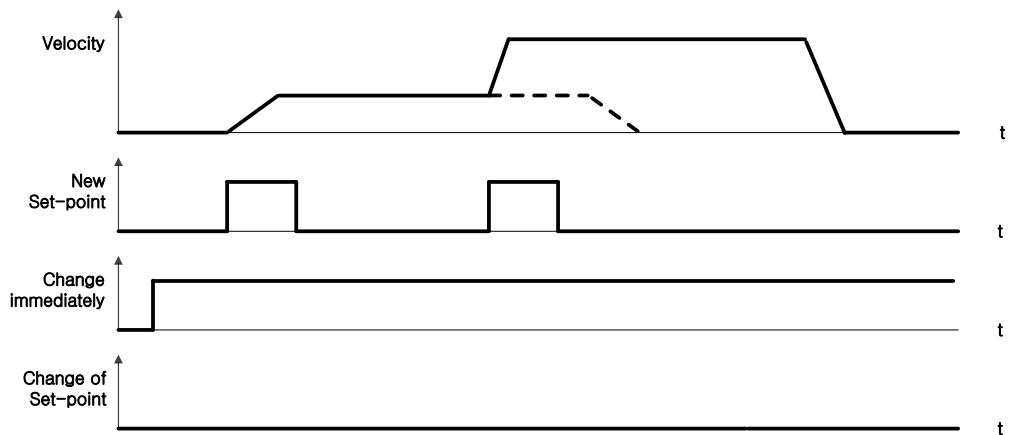

1. Specify the target position (0x607A).
2. Set the New setpoint bit to 1 and the Change set immediately bit to 1 to request the position operation.
3. You can begin a new position operation (New setpoint) regardless of the previous target position.
4. The drive immediately moves to the new position.
5. The drive notifies the operator of its arrival at the target position with the Target reached bit (Statusword, 0x6041.10).

## ■ The set of set point procedure

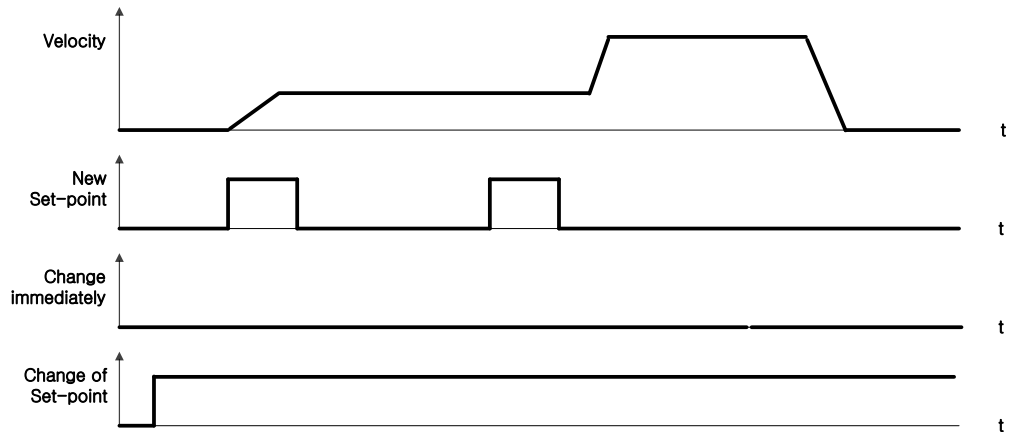

1. Specify the target position (0x607A).
2. Set the New setpoint bit to 1 and the Change of Set point bit to 1 to request the position operation.
3. After reaching the previous target position, the drive begins to move to the new position (New setpoint). The drive retains the previous velocity.
4. The drive notifies the operator of its arrival at the target position with the Target reached bit (Statusword, 0x6041.10).

## 6.3.2 Interpolated Position Mode

Interpolated Position Mode controls multiple axes or a single axis. This mode necessitates time interpolation of the Set point. It can adjust the time of any drive unit associated via the time sync technology.

The interpolation cycle is defined by 0x60C2, and the interpolation data can be entered via 0x60C1.

### ■ The Interpolated Position Mode diagram

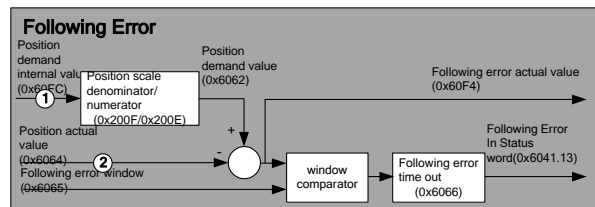
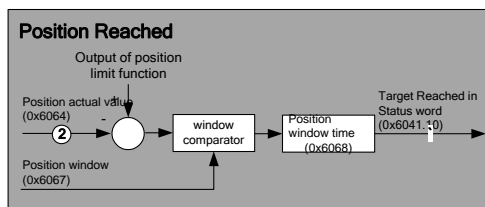
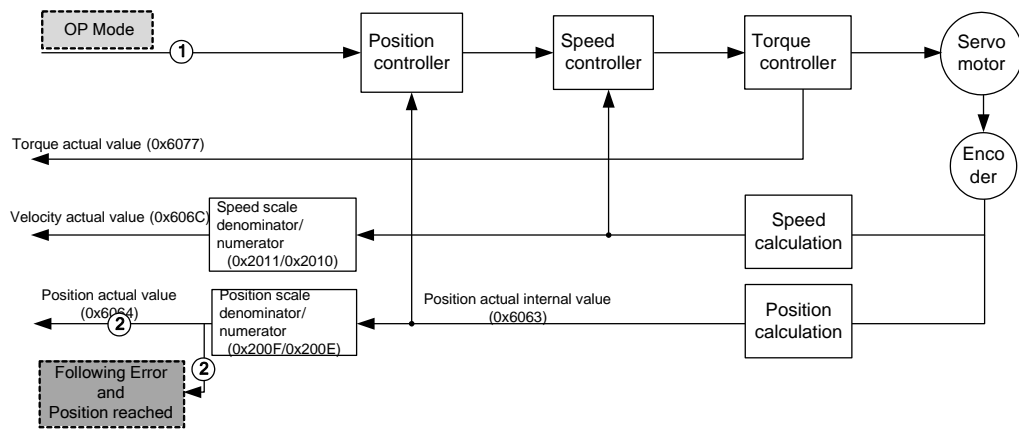
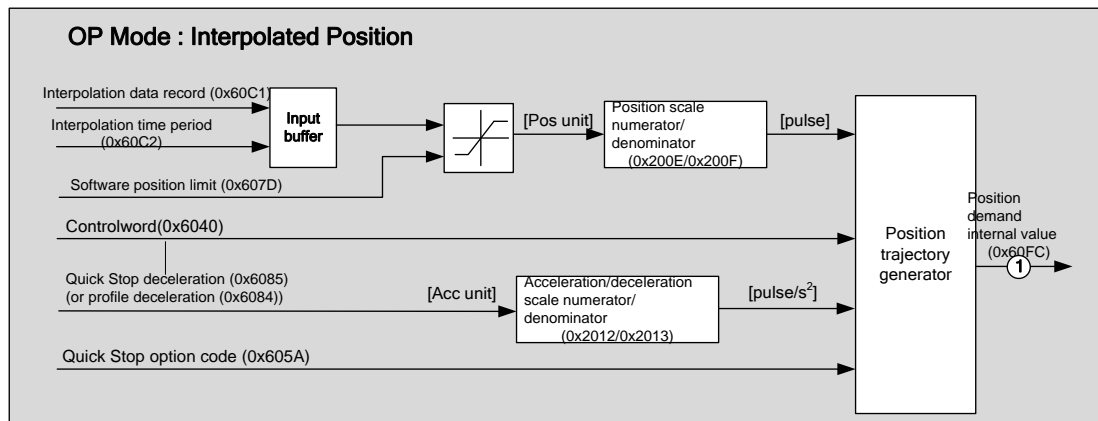

## ■ Related Objects

Index	Sub	Name	Data Type	Access	PDO Mapping	Units
0x6040	-	Controlword	UNIT	RW	Yes	-
0x6041	-	Statusword	UINT	RO	Yes	-
0x60C1	1	Interpolation data record	DINT	RW	Yes	Pos Units
0x607D	-	Software position limit	-	-	-	-
	0	Number of entries	USINT	RO	No	-
	1	Minimum position limit	DINT	RW	No	Pos Units
	2	Maximum position limit	DINT	RW	No	Pos Units
0x6084	-	Profile deceleration	UDINT	RW	Yes	Acc units
0x6085	-	Quick Stop deceleration	UDINT	RW	Yes	Acc units
0x60C2	-	Interpolation cycle (Interpolation Time Period)	-	-	-	-
	0	Number of entries	USINT	RO	No	-
	1	Interpolation cycle (Interpolation time period)	USINT	RW	No	-
	2	Interpolation time index	SINT	RW	No	-

### 6.3.3 Cyclic Synchronous Position Mode

Cyclic Synchronous Position Mode drives the L7N by receiving updated target positions (0x607A) with each POD update cycle from the master. You can use this mode to drive the L7N by adding a torque offset (0x60B2) and speed offset (0x60B1).

The Cyclic Synchronous Position Mode diagram

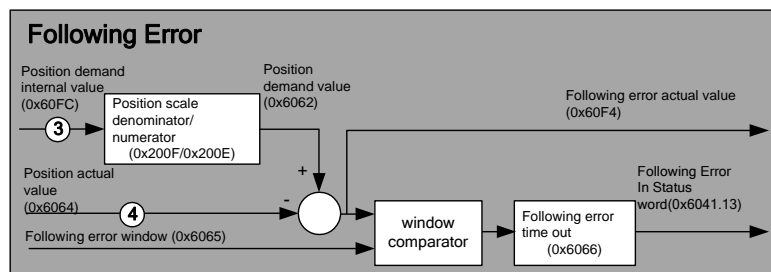
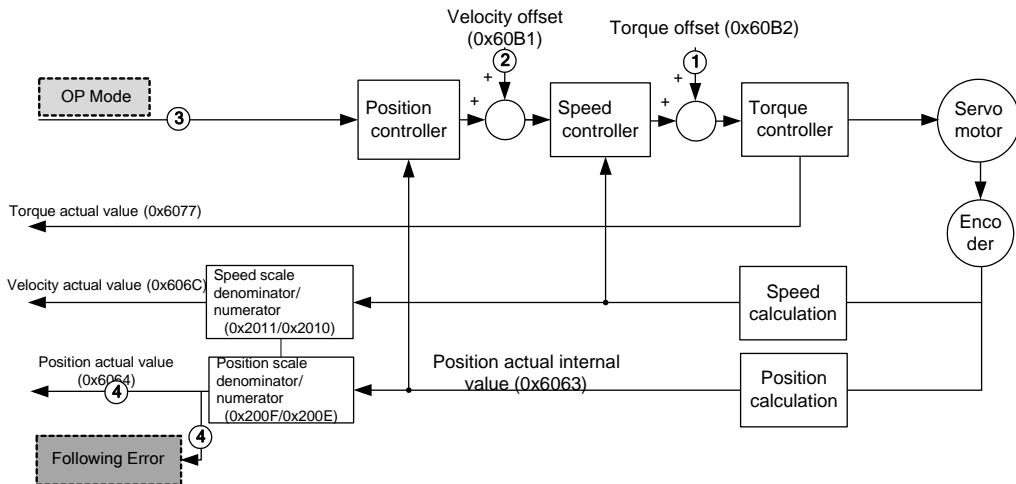
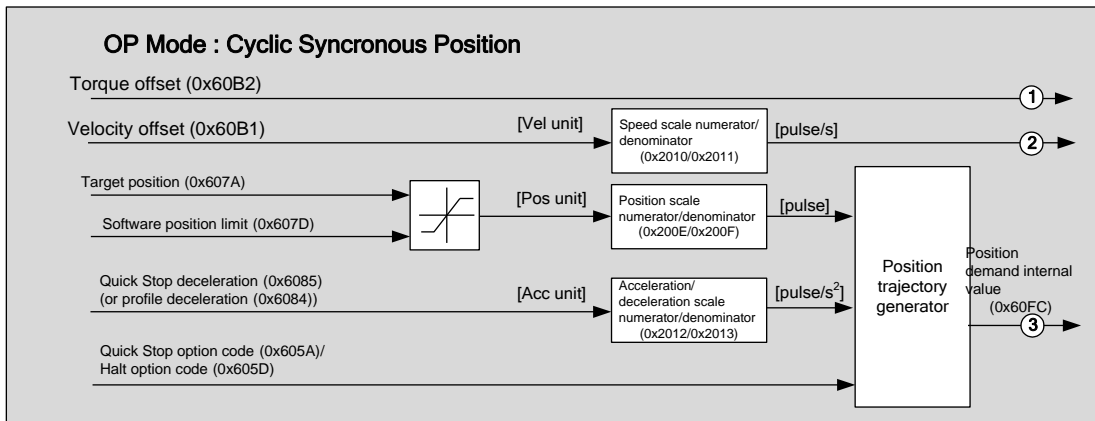

## ■ Related Objects

Index	Sub	Name	Data Type	Access	PDO Mapping	Units
0x607A	-	Target position	DINT	RW	Yes	Pos Units
0x607D	-	Software position limit	-	-	-	-
	0	Number of entries	USINT	RO	No	-
	1	Minimum position limit	DINT	RW	No	Pos Units
	2	Maximum position limit	DINT	RW	No	Pos Units
0x6084	-	Profile deceleration	UDINT	RW	Yes	Acc units
0x6085	-	Quick Stop deceleratio	UDINT	RW	Yes	Acc units
0x60B1	-	Velocity offset	DINT	RW	Yes	Vel units
0x60B2	-	Torque offset	INT	RW	Yes	0.1%

## 6.4 Homing

The following figure outlines the homing inputs and outputs. You can specify the speed, acceleration and homing method. The Home offset allows you to input the origin of the use's coordinate system in the Home, rather than its initial origin.

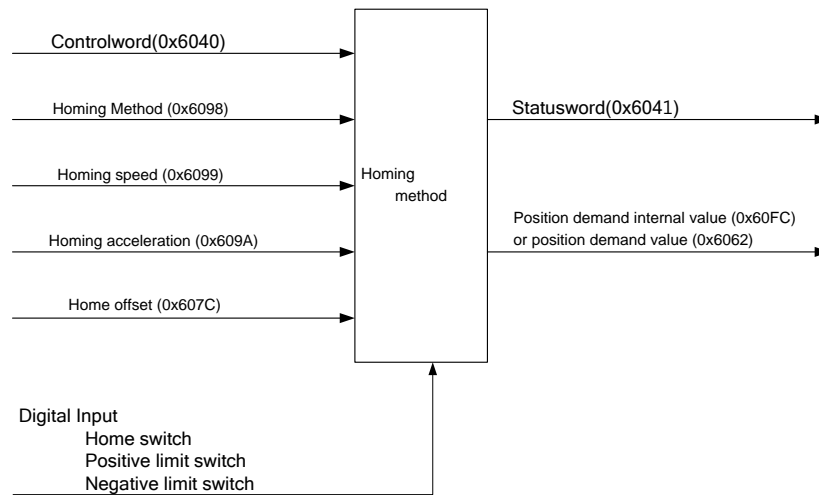

### ■ Related Objects

Index	Sub	Name	Data Type	Access	PDO Mapping	Units
0x6040	-	Controlword	UNIT	RW	Yes	-
0x6041	-	Statusword	UINT	RO	Yes	-
0x607C	-	Home Offset	DINT	RW	No	Pos Units
0x6098	-	Homing Method	SINT	RW	Yes	-
0x6099	-	Homing Velocity	-	-	-	-
	0	Number of entries	USINT	RO	No	-
	1	Switch search speed (Speed during search for switch)	UDINT	RW	Yes	Vel Units
	2	Zero search speed (Speed during search for zero)	UDINT	RW	Yes	Vel Units
0x607D	-	Software position limit (Software Position Limit)	-	-	-	-
	0	Number of entries	USINT	RO	No	-
	1	Minimum position limit (Min. position limit)	DINT	RW	No	Pos Units
	2	Maximum position limit (Max. position limit)	DINT	RW	No	Pos Units
0x609A	-	Homing Acceleration	UDINT	RW	Yes	Acc Units
0x200D	-	Basic function setting (Function Select Switch)	UINT	RW	No	-
0x200E	-	Position scale numerator (Position Scale Numerator)	INT	RW	No	-
0x200F	-	Position scale denominator (Position Scale Denominator)	INT	RW	No	-

### ■ Homing Method (0x6098)

Value	Details
0	No Homing
1, 2	<p>(1) If the NOT switch is OFF, then the initial direction of rotation is CW. The direction is diverted if the NOT switch is ON. After the NOT switch is turned on, the position that the first index pulse encounters while driving in the CCW direction becomes the Home position.</p> <p>(2) If the POT switch is OFF, then the initial direction of rotation is CCW. The direction is diverted if the POT switch is ON. After the POT switch is turned on, the position that the first index pulse encounters while driving in the CW direction becomes the Home position.</p>
7 to 10	<p>The methods described for 7 to 10 determine the Home position using the Home switch and the POT switch.</p> <p>(7) Upper figure: If the POT switch is OFF, then the drive operates at switch search speed and the initial direction of rotation is CCW. The direction is diverted if the Home switch is ON. After the Home switch is turned on, the position that the first index pulse encounters while driving in the CW direction becomes the Home position, and it drives at zero search speed.</p> <p>(7) Middle figure: If the POT switch is OFF and the Home switch is ON, then the drive operates at switch search speed and the initial direction of rotation is CW. If the Home switch is turned off at this time, it transfers to zero search speed. After the Home switch is turned off, the position that the first index pulse encounters while driving in the CW direction becomes the Home position.</p> <p>(7) Lower figure: If the POT switch is OFF and the Home switch is ON, then the drive operates at switch search speed and the initial direction of rotation is CCW. The direction is diverted if the POT switch is ON. If the Home switch is turned from ON to OFF at this time, it drives at zero search speed, and the position that the first index pulse encounters while driving in the CW direction becomes the Home position.</p> <p>The methods from 8 to 10 are identical to the methods for 7 in terms of how they determine the Home position. The only differences are the initial driving direction and Home switch polarity. Refer to the following figure.</p>



Value	Details
11 to 14	<p>The methods described for 11 to 14 determine the Home position using the Home switch and the NOT switch.</p> <p>(11) Upper figure: If the NOT switch is OFF, then the drive operates at switch search speed and rotates CW. If the Home switch is turned on at this time, it changes the direction of rotation, and the position that the first index pulse encounters while driving CCW at zero search speed becomes the Home position.</p> <p>(11) Middle figure: If the NOT switch is OFF and the Home switch is ON, then the drive operates at switch search speed and rotates CCW. If the Home switch is turned off at this time, it transfers to zero search speed. After the Home switch is turned off, the position that the first index pulse encounters while driving in the CCW direction becomes the Home position.</p> <p>(11) Lower figure: If the NOT switch is OFF, then the drive operates at switch search speed and rotates CW. If the NOT switch is turned on at this time, it changes the direction and continues to drive CCW at switch search speed. If the Home switch is then changed from ON to OFF, then it transfers to zero search speed, and the position that the first index pulse encounters becomes the Home position.</p> <p>The methods from 12 to 14 are identical to the methods for 11 in terms of how they determine the Home position. The only differences are the initial driving direction and Home switch polarity. Refer to the following figure.</p>
24	<p>It determines the Home position in the same manner as method 8, but it does not use an index pulse. The point where the Home switch is turned on or off becomes the Home position.</p>

Value	Details
28	<p>It determines the Home position in the same manner as method 12, but it does not use an index pulse. The point, where the Home switch is turned on or off, becomes the Home position.</p> <p>Home switch</p> <p>Negative limit switch (NOT)</p>
33, 34	<p>The position that the first index pulse encounters while driving in a CCW/CW direction becomes the Home position.</p> <p>Index pulse</p>
35	<p>The starting point of the homing operation becomes the Home position.</p>

Note) : Switch search speed (0x6099:01)    : Zero search speed (0x6099:02)    :

## 6.5 Velocity Control Mode

### 6.5.1 Profile Velocity Mode

In Profile Velocity Mode, the L7N accelerates to the target velocity (0x60FF) at the profile acceleration speed (0x6083) and decelerates at the profile deceleration speed (0x6084). The max. profile velocity limits the maximum velocity (0x607F).

#### ■ The Profile Velocity Mode block diagram

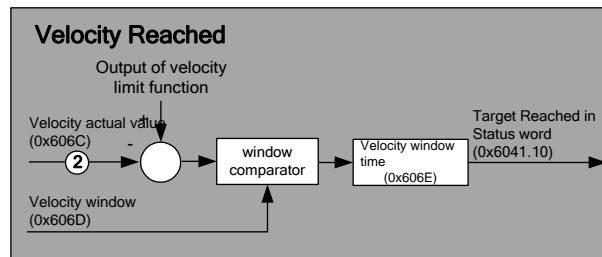
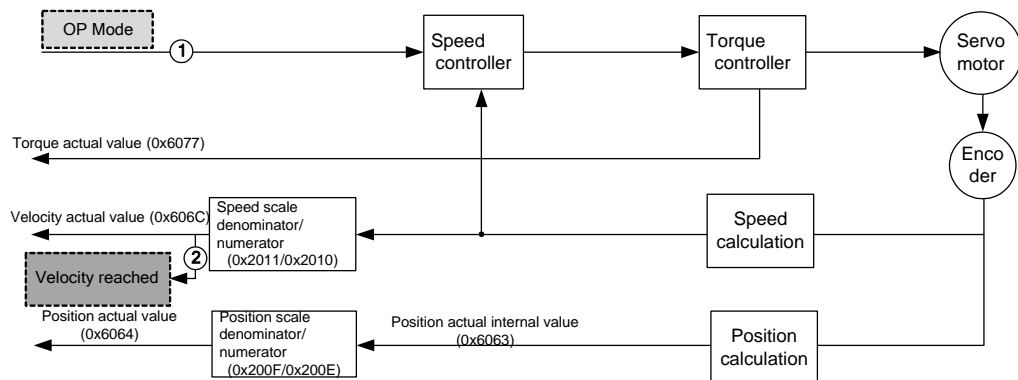
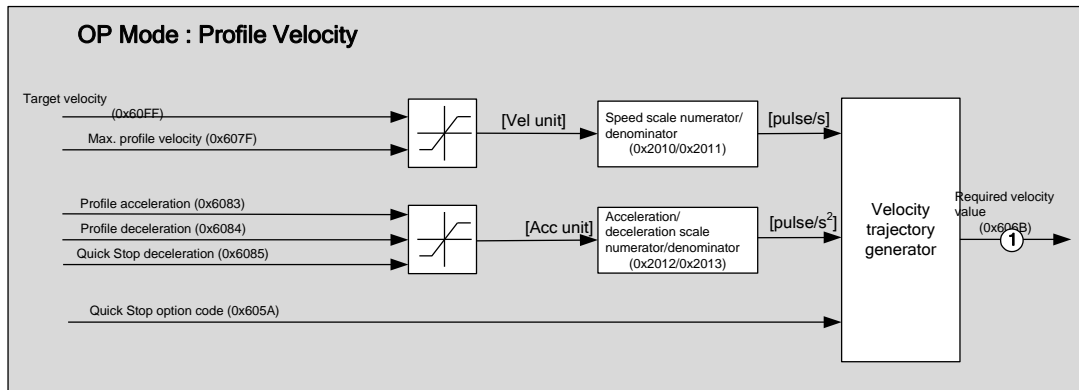

## ■ Related Objects

Index	Sub	Name	Data Type	Access	PDO Mapping	Units
0x60FF	-	Target velocity	DNIT	RW	Yes	Vel Units
0x607F	-	Maximum profile velocity	UDINT	RW	Yes	Vel Units
0x6083	-	Profile acceleration)	UDINT	RW	Yes	Acc units
0x6084	-	Profile deceleration	UDINT	RW	Yes	Acc units
0x6085	-	Quick	UDINT	RW	Yes	Acc units
0x606B	-	Required velocity value (Velocity Demand Value)	DINT	RO	Yes	Vel Units
0x606C	-	Actual velocity value (Velocity Actual Value)	DINT	RO	Yes	Vel Units
0x606D	-	Velocity span (Velocity Window)	UINT	RW	No	Vel Units
0x606E	-	Time to reach the target velocity (Velocity Window Time)	UINT	RW	No	ms

## 6.5.2 Cyclic Synchronous Velocity Mode

In Cyclic Synchronous Velocity Mode, the master orders the target velocity (0x60FF) for the drive and performs velocity control. This mode allows you to add the torque offset (0x60B2) to the master.

### ■ The Cyclic Synchronous Velocity Mode block diagram

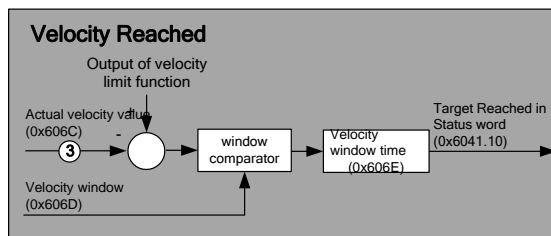
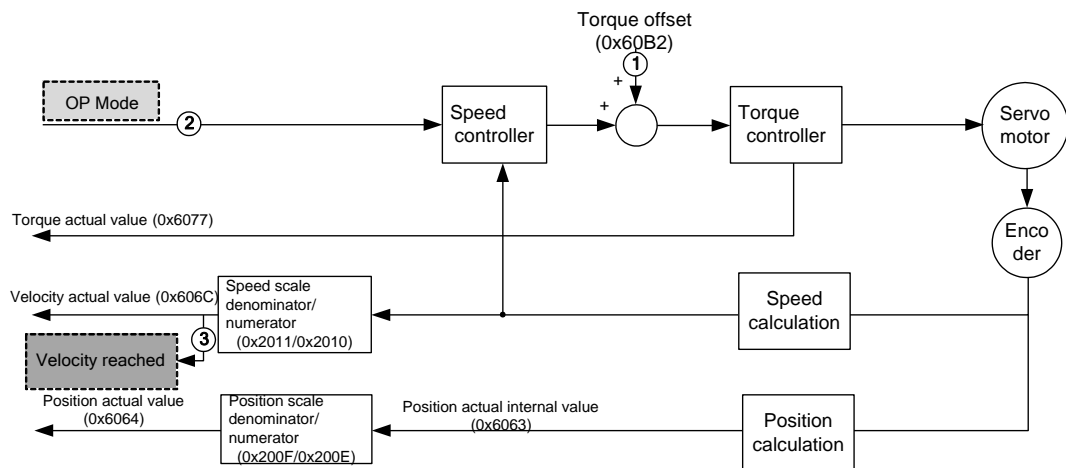
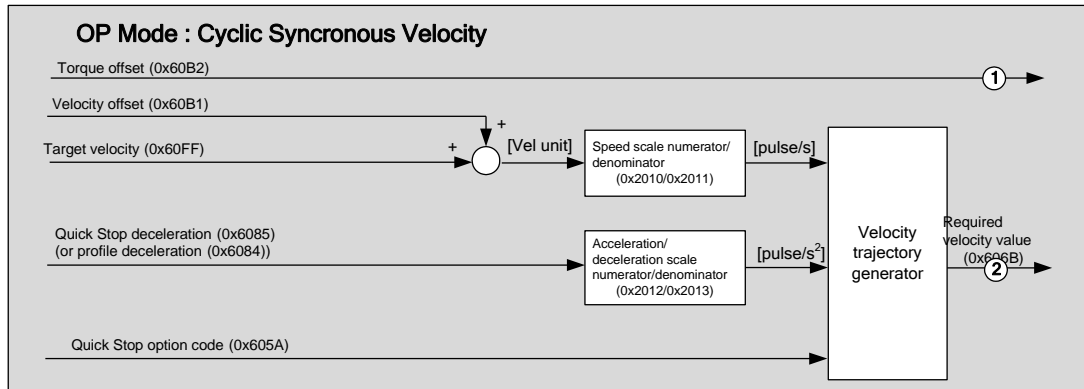

## ■ Related Objects

Index	Sub	Name	Data Type	Access	PDO Mapping	Units
0x60FF	-	Target velocity	DNIT	RW	Yes	Vel Units
0x60B1	-	Velocity offset	DINT	RW	Yes	Vel units
0x60B2	-	Torque offset	INT	RW	Yes	0.1%
0x6084	-	Profile deceleration	UDINT	RW	Yes	Acc units
0x6085	-	Quick Stop deceleration	UDINT	RW	Yes	Acc units
0x606B	-	Required velocity value	DINT	RO	Yes	Vel Units
0x606C	-	Actual velocity valu	DINT	RO	Yes	Vel Units
0x606D	-	Velocity span	UINT	RW	No	Vel Units
0x606E	-	Time to reach the target velocity	UINT	RW	No	ms

## 6.6 Torque Control Modes

### 6.6.1 Profile Torque Mode

In Profile Torque Mode, the drive torque increases or decreases at the rate of the torque gradient (0x6087) up to the target torque (0x6071). The forward/reverse torque limit value (0x60E0, 0x60E1) limits the torque. The max. torque (0x6072) value indicates the maximum torque that can be applied to the motor regardless of the forward/reverse direction.

#### ■ The Profile Torque Mode block diagram

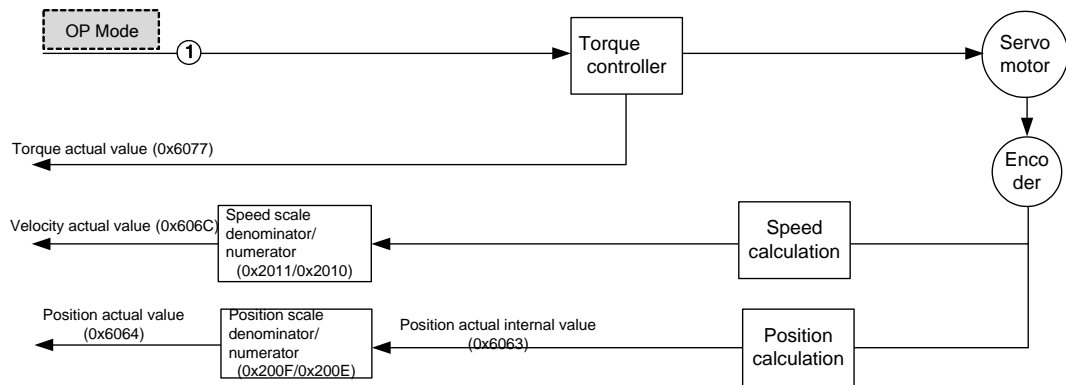
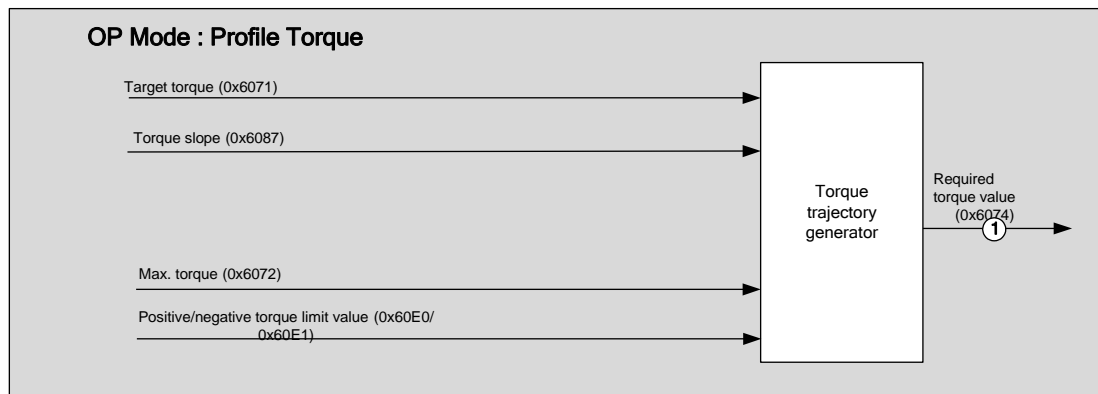

## ■ Related Objects

Index	Sub	Name	Data Type	Access	PDO Mapping	Units
0x6071	-	Target torque	INT	RW	Yes	0.1%
0x6087	-	Torque gradient	UDINT	RW	Yes	0.1%/s
0x6074	-	Required torque value	INT	RO	Yes	0.1%
0x6077	-	Actual torque value	INT	RO	Yes	0.1%
0x6072	-	Max. torque	UINT	RW	Yes	0.1%
0x60E0	-	Forward torque limit value (Positive Torque Limit Value)	UINT	RW	Yes	0.1%
0x60E1	-	Reverse torque limit value (Negative Torque Limit Value)	UINT	RW	Yes	0.1%



## 6.6.2 Cyclic Synchronous Torque Mode

In Cyclic Synchronous Torque Mode, the master orders the target torque (0x6071) for the drive and performs torque control.

### ■ The Cyclic Synchronous Torque Mode block diagram

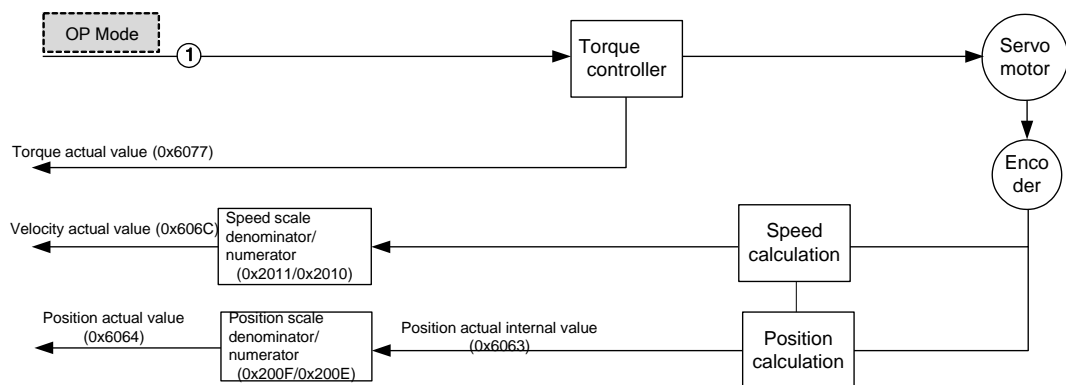
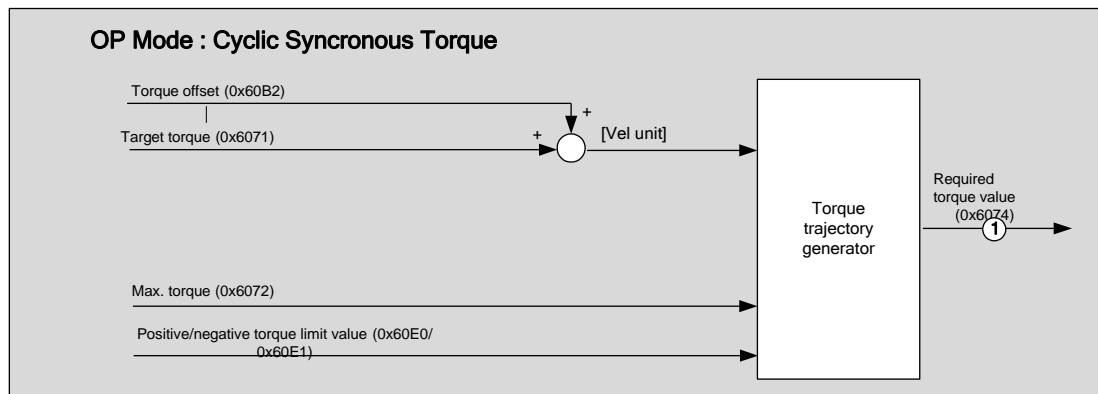

## ■ Related Objects

Index	Sub	Name	Data Type	Access	PDO Mapping	Units
0x6071	-	Target torque	INT	RW	Yes	0.1%
0x6074	-	Required torque value	INT	RO	Yes	0.1%
0x6077	-	Actual torque value	INT	RO	Yes	0.1%
0x60B2	-	Torque offset	INT	RW	Yes	0.1%
0x6072	-	Max. torque	UINT	RW	Yes	0.1%
0x60E0	-	Forward torque limit value (Positive Torque Limit Value)	UINT	RW	Yes	0.1%
0x60E1	-	Reverse torque limit value (Negative Torque Limit Value)	UINT	RW	Yes	0.1%

## 6.7 The Torque Limit Function

The minimum torque limit value (between the forward (0x60E0), reverse (0x60E1) and max. torque (0x6072)) determines the torque limit.

### ■ The Torque Limit Function block diagram

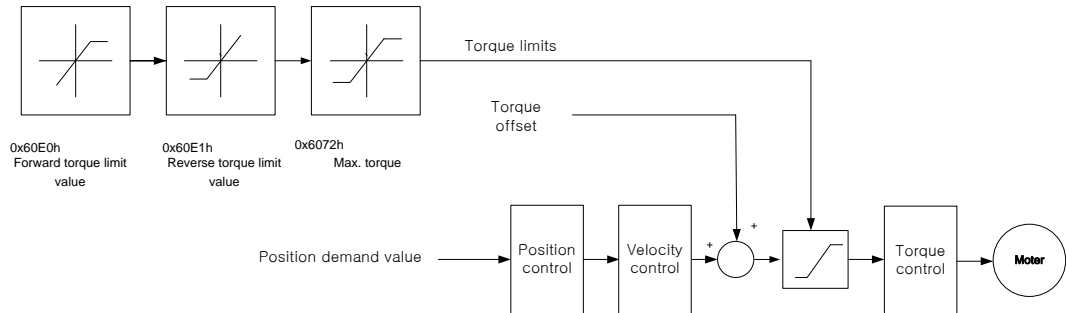

### ■ Related Objects

Index	Sub	Name	Data Type	Access	PDO Mapping	Units
0x6072	-	Max. torque (Max. Torque)	UINT	RW	Yes	0.1%
0x60E0	-	Forward torque limit value (Positive Torque Limit Value)	UINT	RW	Yes	0.1%
0x60E1	-	Reverse torque limit value (Negative Torque Limit Value)	UINT	RW	Yes	0.1%

## 6.8 Digital Input/Output

Digital input/output controls the input/output signal of the CN1 connector on the L7N.

For more information, refer to 7.6 0x60FD (Digital Input) and 0x60FE (Digital Output) of the CiA402 Objects.

### ■ Related Objects

Index	Sub	Name	Data Type	Access	PDO Mapping	Units
0x60FD	-	Digital input (Digital Inputs)	UDINT	RO	Yes	-
0x60FE	-	Digital output (Digital Outputs)	-	-	-	-
	0	Number of entries (Number of entries)	USINT	RO	No	-
	1	Physical output (Physical outputs)	UDINT	RW	Yes	-
	2	Bit mask (Bit mask)	UDINT	RW	No	-

## 6.9 Touch Probe Function

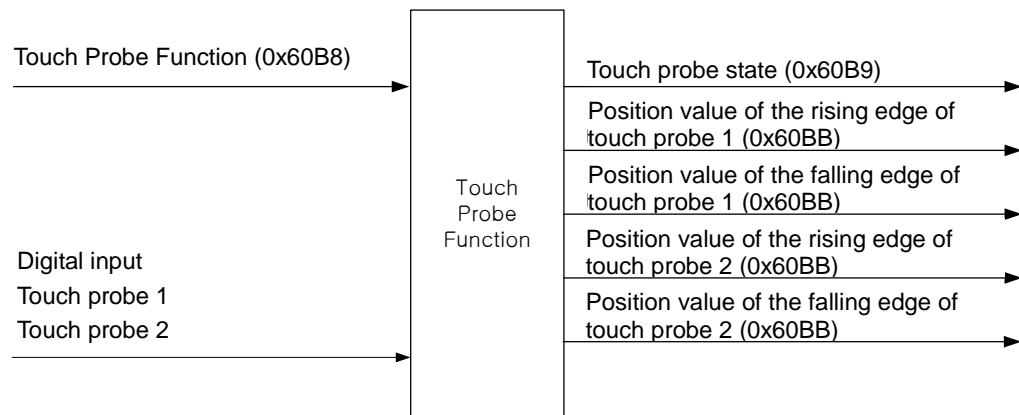

Position feedback is latched to the following trigger events:

- Touch probe 1 (CN1, PROBE1 (pin 9))
- Touch probe 2 (CN1, PROBE2 (pin 10))
- The encoder index pulse

You can use the following two touch probe functions simultaneously:

### ■ Touch probe 1 latch function (For more information, see Section 6.5)

- Bits related to latch control: 0x60B8.0~7
- Bits related to latch status: 0x60B9.0~7
- Position value of the rising edge of touch probe 1: 0x60BA
- Position value of the falling edge of touch probe 1: 0x60BB
- Trigger signal: Encoder Z signal/probe 1 signal

### ■ Touch probe 2 latch function (For more information, see Section 6.5)

- Bits related to latch control: 0x60B8.8~15
- Bits related to latch status: 0x60B9.8~15
- Position value of the rising edge of touch probe 2: 0x60BC
- Position value of the falling edge of touch probe 2: 0x60BD
- Trigger signal: Probe 2 signal

## ■ Related Objects

Index	Sub	Name	Data Type	Access	PDO Mapping	Units
0x60B8	-	Touch probe function	UINT	RW	Yes	-
0x60B9	-	Touch probe status	UINT	RO	Yes	-
0x60BA	-	Position value of the rising edge of touch probe 1 (Touch Probe 1 Positive Edge Position Value)	DINT	RO	Yes	Pos units
0x60BB	-	Position value of the falling edge of touch probe 1 (Touch Probe 1 Negative Edge Position Value)	DINT	RO	Yes	Pos units
0x60BC	-	Position value of the rising edge of touch probe 2 (Touch Probe 1 Positive Edge Position Value)	DINT	RO	Yes	Pos units
0x60BD	-	Position value of the falling edge of touch probe 2 (Touch Probe 1 Negative Edge Position Value)	DINT	RO	Yes	Pos units

## ■ Touch Probe Timing Diagrams

### ▪ Single Trigger Mode (0x60B8.1=0, 0x60B8.9=0)

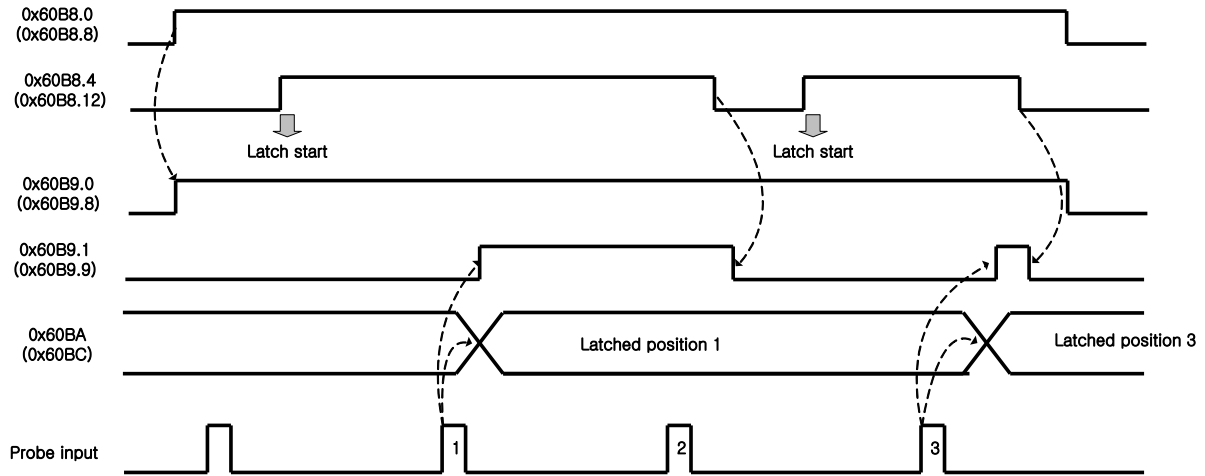

### ▪ Continuous Trigger Mode ((0x60B8.1=0, 0x60B8.9=0))

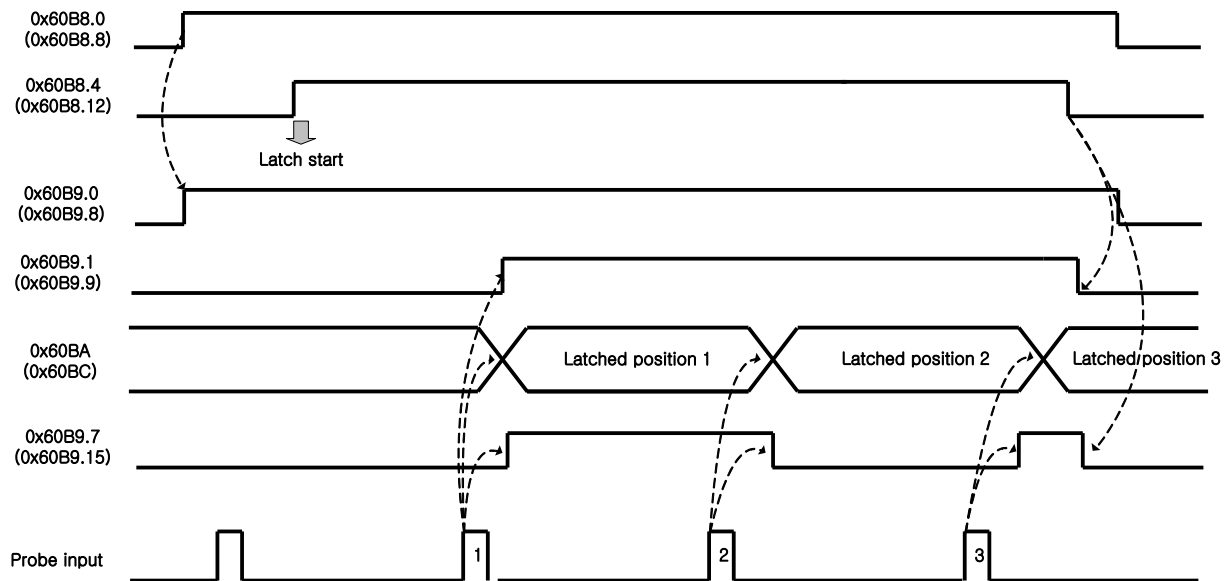

▪ **Z-Phase signal Trigger mode (60B8h bit2 = 1, or bit10 = 1)**

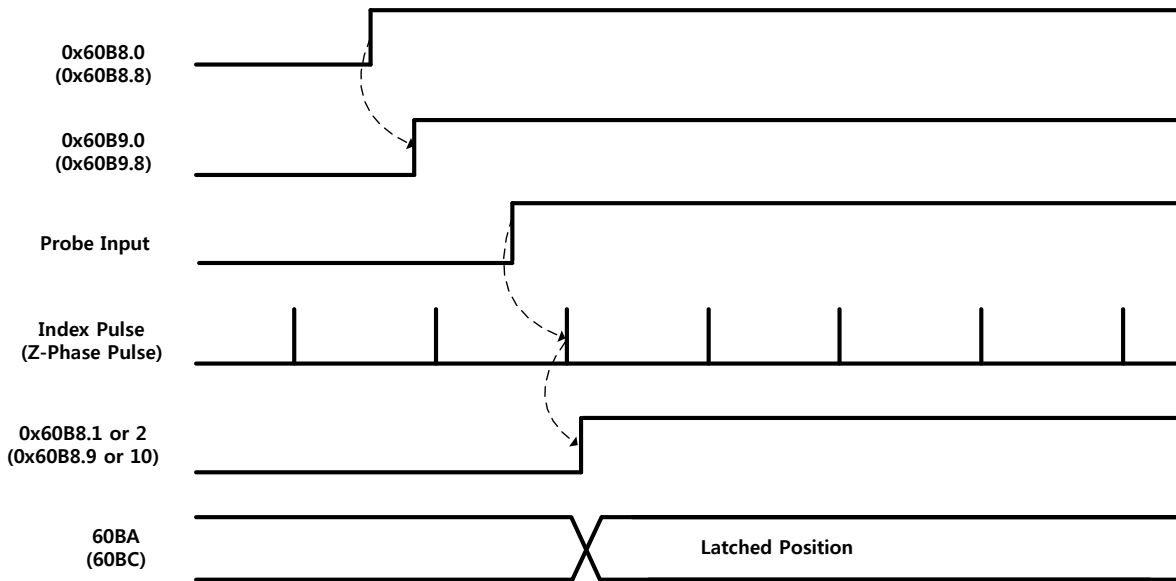



# 7. L7 Drive Setup

## 7.1 Setting System Parameters

1. The motor ID setting [0x2000]
  - Serial encoder: Reads the motor ID from the encoder and configures it.
2. Encoder settings

When connecting Motor with single-turn encoder, it is automatically set motorID(0x2000), encoder pulse(0x2002)value. In case of Multiturn serial encoder, Set the encoder type.

- Encoder type [0x2001]

Number	Encoder Type	Number	Encoder Type
1	Singleturn serial encoder	1	Multiturn serial encoder

- Encoder pulse [0x2002]
  - Indicates the pulses per revolution in a bit for the encoder type ( $2^{n(\text{bit})}$ ).

3. Main power input mode [0x2003]
  - Specifies the main power input mode and the processing mode if phase loss occurs. You can specify the handling methods for three-phase and single-phase power inputs and the power phase loss (Refer to section 7.5).
4. The main power phase loss monitoring interval [0x2004]
  - Specifies the monitoring interval for main power phase losses.
5. The 7SEG display object setting [0x2005]
  - Specifies the objects applied when the servo turns on.
  - The setting values range from [0x2600] to [0x2616]. Choose a number from 2600-2616 and use that number to set the corresponding parameter. . You can display the number and value of the variable every time you press the panel operator switch. For 32-bit variables, press and hold the switch to indicate the upper/middle/lower locations in 4 figures.
6. The regenerative overload derating factor [0x2006]
  - This specifies the derating factor which checks for regenerative resistance overloads. If the derating value is 100% or less, then the overload alarm trigger time is proportional to the set value.
7. The regenerative resistance value [0x2007]
  - This specifies the resistance value for regenerative braking resistance. If it is set to 0, then it uses the default resistance capacity embedded in the drive.
8. The regenerative resistance capacity [0x2008]

This specifies the current capacity for regenerative resistance. If it is set to 0, then it uses the default resistance capacity embedded in the drive.

**9.** The overload check default load factor [0x2009]

This indicates the load factor which triggers a continuous overload check. If it is set to 100 or less, then the overload check starts early and the overload alarm triggers early.

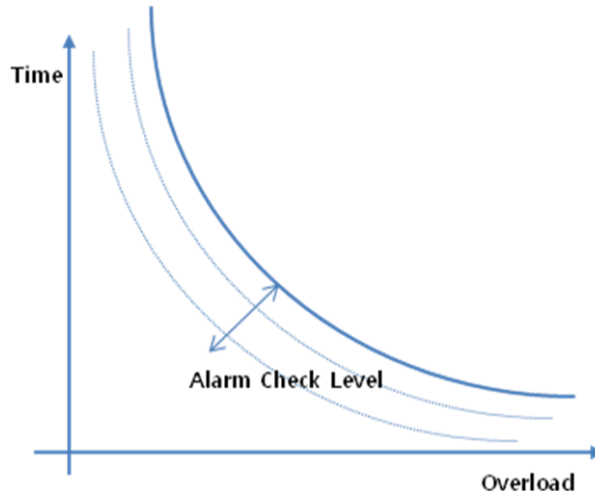

**10.** The overload warning level [0x200A]

This specifies the level for the continuous overload warning signal output. The warning signal is issued when it reaches the setting of the percentage value relative to the alarm trigger value.

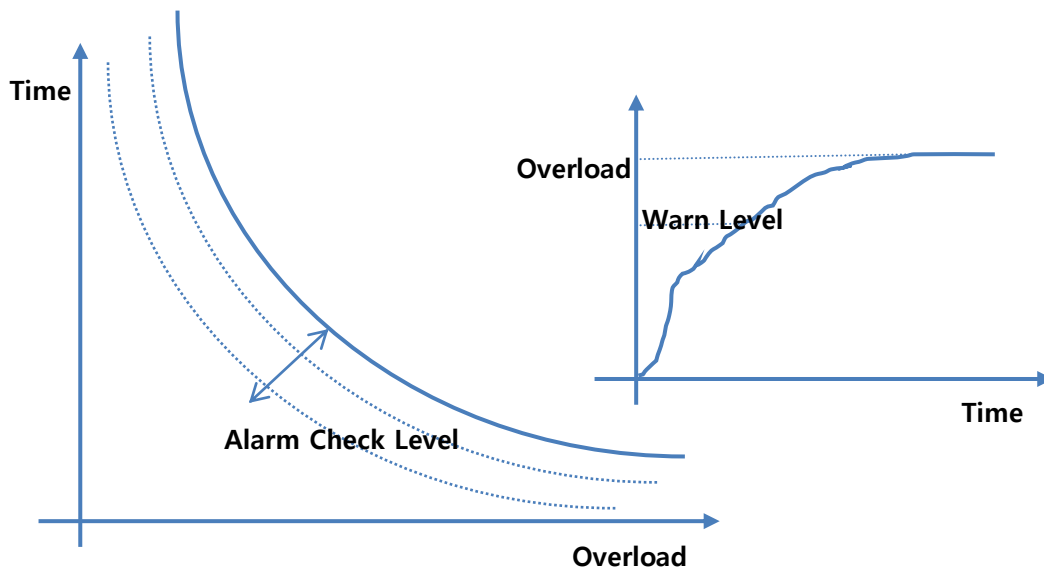

11. The PWM Off delay time [0x200B]

This specifies the time span between the servo Off command and actual PWM Off. This prevents the motor from slipping down the vertical axis while the servo Off command and brake command order the motor brake to engage. Use a PWM off delay when operating a motor brake through the output contact point brake signal. (range: 0-1000 ms, initial value: 10).

12. The DB control mode [0x200C]: Specifies the DB control mode. You can use the following four modes: (Refer to section 7.5)

Mode	Operation type
Hold after a DB stop	<p>Servo ON, Off</p> <p>DB</p> <p>Velocity</p> <p>The diagram shows three signals over time. 'Servo ON, Off' is a pulse that goes high and then low. 'DB' is a pulse that goes high during the servo off period. 'Velocity' is a pulse that goes high during the servo on period and low during the servo off period.</p>

Mode	Operation type
Release after a DB stop	
Release after a free run stop	
Hold after a free run stop	

13. The basic servo function setting bit [0x200D]: Specifies the drive function. You can set it to move forward, in reverse or to operate the servo lock function. (refer to section 8.5).

## 7.2 Configuring Control Parameters

The control parameter setting sequence is as follows:

- Load the inertia ratio [0x2100] setting.
- Adjust the proportional gain with [0x2101] and [0x2102].

Increase the gain so that the servo motor does not overshoot or lose control (do not use during speed operations or torque operations).

- Adjust the speed proportional gain with [0x2106] and [0x2107].

Increase the gain so that the servo motor does not vibrate.

- Adjust the speed integral time constant with [0x2108] and [0x2109].

Refer to the following table and set it according to the speed proportional gain.

### 7.2.1 The Inertia Ratio Setting [0x2100]

This sets the inertia ratio by calculating the load inertia from the machine system and rotor inertia listed on the motor specification table.

$$\text{Inertia ratio} = \text{load inertia} / \text{motor rotor inertia} \times 100$$

The inertia/load ratio is an important control parameter for the operation of the servo. It is crucial to set the correct inertia ratio for optimal servo operation.

The following table outlines the recommended control gain for different inertia ratios:

Motor Flange	Inertia ratio		Gain Range		
	Category	Inertia (Multiple)	Position Proportional Gain	Speed Proportional Gain	Speed Integral Gain
40 ~ 80	Low inertia	1 ~ 5	40 ~ 90	400 ~ 1000	10 ~ 40
	Medium inertia	5 ~ 20	20 ~ 70	200 ~ 500	20 ~ 60
	High inertia	20 ~ 50	10 ~ 40	100 ~ 300	50 ~ 100

\* You can tune the inertia ratio during a test drive if it is too hard to calculate the inertia ratio before operation.

## 7.2.2 The Position Control Gain

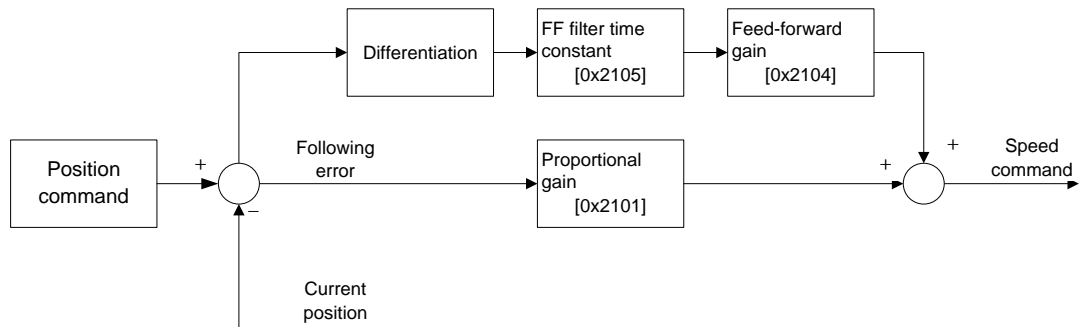

- **Position command:** Counts the position command pulses entering from outside and converts them into position commands. It uses them as internal position commands after initial filtering.
- **Current position:** Counts the pulse signals received from the encoder and uses the electronic gear ratio settings to convert them to the current position.
- **Position proportional gain [0x2101] and [0x2102]:** Converts the difference between the position command and the current position into a speed command by multiplying it by the position proportional gain.
  - Recommended value = speed proportional gain [0x2106] / 10
- **Feed-forward gain [0x2104]:** Uses the differences in value to the position command to calculate the gradient. Adds the speed command to the gradient to reduce the time needed to reach the target position. If the value which results is too large, then the position controller may overshoot or become unstable. It is important to gradually increase the value from a small value while monitoring the test drive.
- **Feed-forward filter [0x2105]:** The feed-forward control filter vibrates if the position command changes too drastically. If this occurs, configure the filter value until the vibrations disappear.

### 7.2.3 The Speed Control Gain

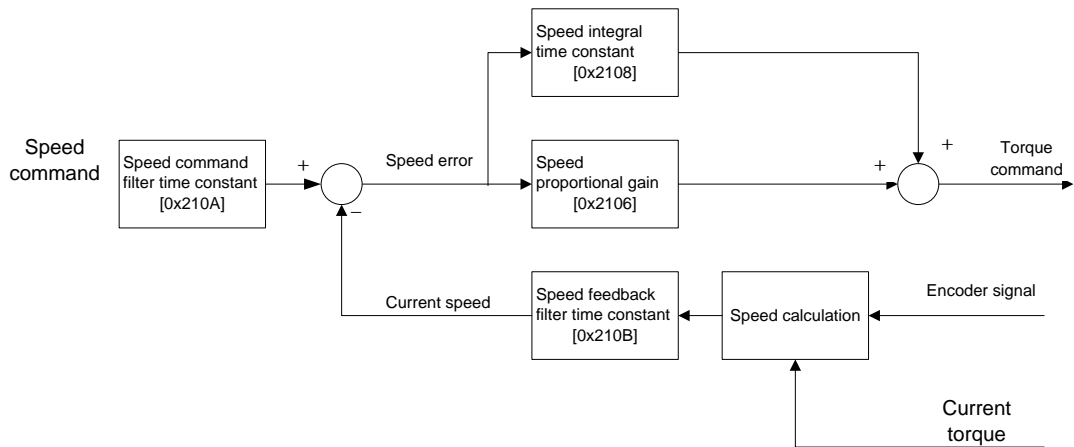

- **Speed command:** Operates the speed command through the speed command filter [0x210A].
- **Current speed:** Calculates the speed by counting the number of encoder signals as time progresses. Filters the speed to calculate the current speed. The algorithm uses the current torque and inertia to project the speed and compensate for errors which occur when calculating the speed at very low speeds. Therefore, an accurate motor constant and inertia ratio are closely related to the stability of the motor speed control.
- **Speed integral time constant [0x2108]:** Calculates the integral value of the speed error. The speed error is the difference between the command speed and the current speed. The speed integral time constant converts the speed error into a torque command by multiplying it by the integral time constant.

A decreased integral time constant solves transient response issues and improves speed tracking. If the integral time constant is too small, however, an overshoot occurs. On the other hand, if the integral time constant is too large, an excessive response drop occurs and proportional control takes over.

- Recommended value = 10000/speed proportional gain [0x2106]

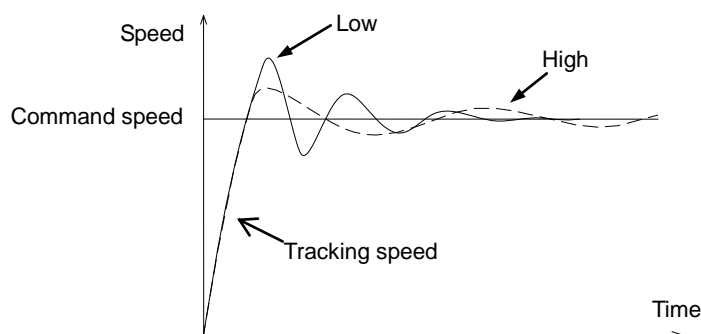

- **Speed proportional gain [0x2106]:** Converts the speed error into a torque command by multiplying it by the proportional gain.

If the resulting value is large, then the speed response accelerates and speed tracking increases. However, vibrations occur if the value is too large. If the value is too small, then speed response slows down and speed tracking decreases. This may cause the servo to lose power.

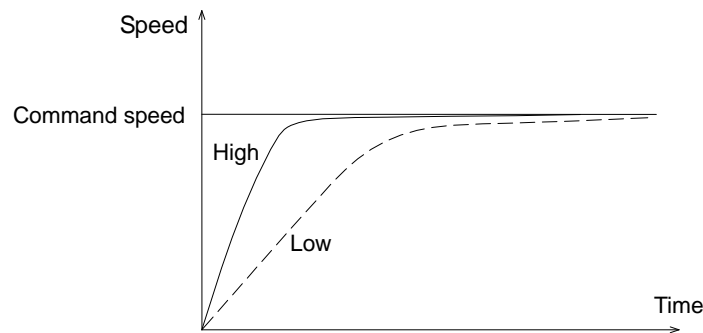

- **Speed feedback filter time constant [0x210B]:** Filters the speed feedback to control vibrations when the speed of the motor changes due to drive system vibrations or vibrations due to gain and too much load inertia. If the value is too high, it reduces speed responsiveness and control power may be compromised.
  - Recommended value = 0 to speed integral time constant [0x2108]/10

## 7.2.4 The Torque Command Filter Time Constant Time [0x210C]

Use a digital filter for the analog torque command voltage to improve the stability of command signals. If the filter value is set too high, responsiveness to torque commands will be reduced. It is important to set an appropriate value for your system.

## 7.2.5 Gain 1 ↔ Gain 2 Transfer Mode [0x210D]

Set the gain transfer mode. You can set the transfer method with the zero speed conditions, position reached status, contact input status, etc. (refer to section 8.5).

## 7.2.6 Gain 1 ↔ Gain 2 Transfer Time [0x210E]

Configure the gain transfer time during operation.

When converting gain 1 to gain 2 or gain 2 to gain 1, the conversion occurs according to the set time.

## 7.2.7 P/PI Transfer Mode [0x210D]

Configure the P and PI transfer modes. You can configure the set conditions, set speed, set acceleration, set position error, etc. for the transfer method (refer to section 7.5).



## 7.2.8 Resonance Avoidance Operations [0x210F], [0x2110], [0x2111]

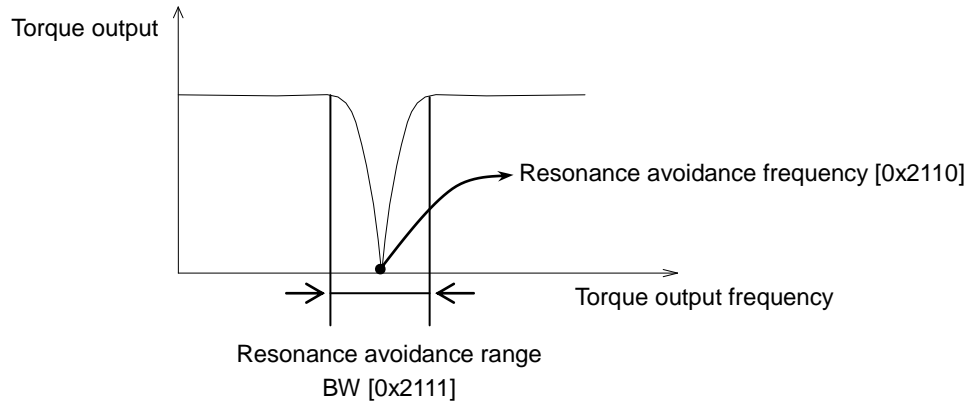

Mechanical resonance causes vibrations to occur at certain frequencies in certain systems. You can control the vibrations by controlling the torque output for specific frequencies.

- The resonance avoidance operation [0x210F] (refer to section 8.5).

## 7.3 Setting the Input/Output Contact Point Parameters

- There are 6 points for digital inputs (totaling 8 functions): + PROBE1, PROBE2  
: PCON, GAIN2, ALMRST, HOME, P-OT, N-OT
- There are 4 points for digital outputs (totaling 7 functions):  
: ALARM, READY, ZSPD, BRAKE, INPOS, INSPD, WARN
- You can assign input/output signals by parameter and set the input/output contact logic (A/B contacts).  
: Input signal definition (0x2200, 0x2201)  
: Output signal definition (0x2202, 0x2203)  
: Input signal logic setting (0x2204)  
: Output signal setting (0x2205)
- For PROBE1 (CN1-9)/PROBE2 (CN1-10), the pins are assigned separately and interrupted for the inputs.
- Basic settings for input signal definitions

Object		Input Signal	CN1 Pin Default Allocation Number						Default Setting Value
Index	Bit		DI#6(7)	DI#5(8)	DI#4(14)	DI#3(12)	DI#2(14)	DI#1(13)	
0x2200	0 to 3	PCON	6	5	4	3	2	1	0x4000
0x2200	4 to 7	GAIN2	6	5	4	3	2	1	
0x2200	8 to11	A-RST	6	5	4	3	2	1	
0x2200	12 to 15	HOME	6	5	4	3	2	1	
0x2201	0 to 3	P-OT	6	5	4	3	2	1	0x0065
0x2201	4 to 7	N-OT	6	5	4	3	2	1	

- Logic definitions for input signals (0x2204)-- logic settings for DI#1 to DI#6 by bit.

Bit	function	Value (Hex)	Setting details
0	DI#1 input logic setting	0	Contact B
		1	Contact A <sup>Note 1)</sup>
1	DI#2 input logic setting	0	Contact B
		1	Contact A <sup>Note 1)</sup>
2	DI#3 input logic setting	0	Contact B
		1	Contact A <sup>Note 1)</sup>
3	DI#4 input logic setting	0	Contact B
		1	Contact A <sup>Note 1)</sup>
4	DI#5 input logic setting	0	Contact B
		1	Contact A <sup>Note 1)</sup>
5	DI#6 input logic setting	0	Contact B
		1	Contact A <sup>Note 1)</sup>

**Note 1)** The default setting value.

- Basic settings for the output signal definitions

Object		output signal	CN1 Pin Default Allocation Number				Default Setting Value
Index	Bit		DO#4 (1,2)	DO#3 (19,20)	DO#2 (17,18)	DO#1 (3,4)	
0x2202	0 to 3	ALARM	4	3	2	1	0x4321
0x2202	4 to 7	READY	4	3	2	1	
0x2202	8 to11	ZSPD	4	3	2	1	
0x2202	12 to 15	BRAKE	4	3	2	1	
0x2203	0 to 3	INPOS	4	3	2	1	0x0000
0x2203	4 to 7	INSPD	4	3	2	1	
0x2203	8 to11	WARN	4	3	2	1	
0x2203	12 to 15	RESERVED	4	3	2	1	

- Logic definitions for output signals (0x2205)-- output logic settings for DO#1 to DO#4 by bit

Bit	function	Value (Hex)	Setting details
0	DO#1 input logic setting	0	Contact B <sup>Note 1)</sup>
		1	Contact A.
1	DO#2 input logic setting	0	Contact B
		1	Contact A <sup>Note 1)</sup>
2	DO#3 input logic setting	0	Contact B
		1	Contact A <sup>Note 1)</sup>
3	DO#4 input logic setting	0	Contact B <sup>Note 1)</sup>
		1	Contact A

**Note 1)** The default setting value.

## 7.4 Setting Speed Operation Parameters

### 7.4.1 Acceleration/Deceleration Time

- Acceleration time [0x2301]: Specifies the time required, in ms, for the motor to reach the rated motor speed from zero speed.
- Deceleration time [0x2302]: Specifies the time, in ms, required for the motor to stop after running at the rated motor speed.

### 7.4.2 The S-Curve Operation [0x2304]

You can configure the acceleration/deceleration operation in an S-curve pattern for smooth acceleration/deceleration.

- 0: Trapezoidal -> Configure the acceleration/deceleration time in [0x2301] and [0x2302].
- 1: Sinusoidal -> Configure the acceleration/deceleration time in [0x2301] and [0x2302] + S-curve time in [0x2303].

### 7.4.3 The Manual JOG Operation Speed [0x2305]

Drive the forward/reverse rotation at the JOG operation speed. This ignores the CN1 contact point input status.

## 7.5 Setting Position Operation Parameters

### 7.5.1 Backlash Compensation [0x2403]

If the position operation causes backlashes which change the position, then this setting converts backlash amount into a number of pulses to compensate for the backlash.

## 7.6 Setting Parameters for L7N Built-in Functions

Configure the default parameters that the L7N provides.

### 7.6.1 Checking/Deleting the Alarm History [0x2700]

You can check and delete the alarm history.

- Delete the Alarm History [0x2700:1]
  - This allows you to delete the alarm history.
- Check the Alarm History [0x2700:2 to 21]
  - This allows you to check the last 20 alarm history items in sequence (the most recent appear first).

### 7.6.2 Auto Gain Tuning [0x2701]

- Start Auto Gain Tuning [0x2701:1]
  - Starts auto gain tuning.
- Auto Gain Tuning Speed [0x2701:2]
  - Specifies the auto gain tuning speed in 100 RPM increments.
- Auto Gain Tuning Distance [0x2701:3]
  - Specifies the auto gain tuning distance.

### 7.6.3 Absolute Encoder Reset [0x2702]

- Reset encoder [0x2702:1]
  - Type "rse" (72 73 65 74) to save the offset in the EEPROM inside the drive. The absolute encoder resets after a few milliseconds.
  - When the absolute encoder reset is complete, the multi-turn data (0x260F) and single-turn data (0x260D) resets to 0.
  - Check whether the actual position value (0x6064) becomes 0 to confirm the reset.
  - After resupplying power to the machine, read the absolute encoder position and apply the home offset (0x607C) to display the actual position value (0x6064). At this time, the actual position value (0x6064) does not change even if you change the home offset (0x607C) while driving.



## 8. Object Dictionary

### 8.1 The Object Dictionary List

The following table shows the Object Dictionary List.

Object Dictionaries	Object	Name
General Objects	0x1000	Device Type
	0x1001	Error Register
	0x1008	Manufacturer Device Name
	0x1009	Hardware Version
	0x100A	Software Version
	0x1010	Store Parameters
	0x1011	Restore Default Parameters
	0x1018	Identity Object
PDO Mapping Objects	0x1600 ~ 0x1603	Receive PDO Mapping
	0x1A00 ~ 0x1A03	Transmit PDO Mapping
Sync Manager Communication Objects	0x1C00	Sync Manager Communication Type
	0x1C10 ~ 0x1C13	Sync Manager PDO Assignment
	0x1C32 ~ 0x1C33	Sync Manager Synchronization
Manufacturer Specific Objects	0x2000 ~0x26FF	L7N Parameters
	0x2000 ~ 0x2013	Control Setting Parameter
	0x200E 0x200F	Position User Unit
	0x2010 0x2011	Velocity User Unit
	0x2012 0x2013	Acceleration User Unit
	0x2700 0x2701	Driving Operation Parameter

Device Control	0x603F	Error Code
	0x6040	Controlword
	0x6041	Statusword
	0x605A	Quick Stop Option Code
	0x605B	Shutdown Option Code
	0x605C	Disable Operation Option Code
	0x605D	Halt Option Code
	0x605E	Fault Reaction Option Code
	0x6060	Modes of Operation
	0x6061	Modes of Operation Display
	0x6502	Supported Drive Modes
Profile Position Mode	0x607A	Target Position
	0x607D	Software Position Limit
	0x607F	Max. Profile Velocity
	0x6081	Profile Velocity
	0x6083	Profile Acceleration
	0x6084	Profile Deceleration
	0x6085	Quick Stop Deceleration
Homing Mode	0x607C	Home Offset
	0x6098	Homing Method
	0x6099	Homing Speeds
	0x609A	Homing Acceleration
Position Control Function	0x6062	Position Demand Value
	0x6063	Position Actual Internal Value
	0x6064	Position Actual Value
	0x60FC	Position Demand Internal Value
	0x6065	Following Error Window
	0x6066	Following Error Time Out
	0x60F4	Following Error Actual Value
	0x6067	Position Window
	0x6068	Position Window Time



Interpolated Position Mode	0x60C1	Interpolation Data Record
	0x60C2	Interpolation Time Period
Cyclic Synchronous Position Mode	0x60B1	Velocity Offset
	0x60B2	Torque Offset
Profile Velocity/Cyclic Synchronous Velocity Mode	0x606B	Velocity Demand Value
	0x606C	Velocity Actual Value
	0x606D	Velocity Window
	0x606E	Velocity Window Time
	0x60FF	Target Velocity
Profile Torque/Cyclic Synchronous Velocity Mode	0x6071	Target Torque
	0x6074	Torque Demand Value
	0x6087	Torque Slope
	0x6076	Motor Rated Torque
	0x6077	Torque Actual Value
Torque Limit Function	0x6072	Max. Torque
	0x60E0	Positive Torque Limit Value
	0x60E1	Negative Torque Limit Value
Touch Probe Function	0x60B8	Touch Probe Function
	0x60B9	Touch Probe Status
	0x60BA	Touch Probe 1 Position Value
	0x60BC	Touch Probe 2 Position Value
Digital Inputs/Outputs	0x60FD	Digital Inputs
	0x60FE	Digital Outputs

## 8.2 General Objects

### 0x1000, Device Type

The following table lists device types and their functions.

Index 0x1000		Device Type					
Sub Index	Initial value	Data Type	Access	PDO Mapping	Setting Range	Change	Unit
0	0x00020192-	UDINT	RO	No	-	-	-

- Details

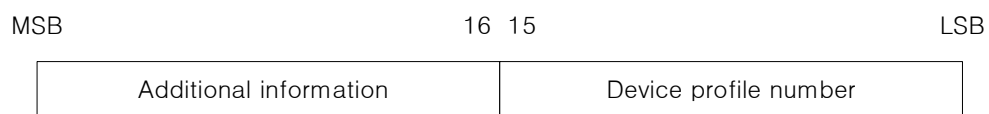

- Additional information: 0x0002 (Servo drive)
- Device profile number: 0x0192 (DS402)

### 0x1001, Error Register

The following table shows the error register values for each device. This value is stored in the emergency message.

Index 0x1001		Error Register					
Sub Index	Initial value	Data Type	Access	PDO Mapping	Setting Range	Change	Unit
0	0x0	USINT	RO	No	-	-	-

- Details

Bit	function	Value (Hex)	Setting details
0	General error	0	No error
		1	Error
1 to 7	Reserved	-	0 : Always

### 0x1008, Manufacturer Device Name

The following table shows the device model name.

Index 0x1008		Manufacturer Device Name					
Sub Index	Initial value	Data Type	Access	PDO Mapping	Setting Range	Change	Unit
0	0x0	STRING	RO	No	-	-	-

### 0x1009, Hardware Version

The following table shows the hardware version of the device.

Index 0x1009		Hardware Version					
Sub Index	Initial value	Data Type	Access	PDO Mapping	Setting Range	Change	Unit
0		STRING	RO	No	-	-	-

### 0x100A, Software Version

The following table shows the software version included with the device.

Index 0x100A		Software Version					
Sub Index	Initial value	Data Type	Access	PDO Mapping	Setting Range	Change	Unit
0		STRING	RO	No	-	-	-

## 0x1010, Store Parameters

The following table shows the parameter settings that you can store in the memory.

Index 0x1010		Store Parameters					
Number of entries							
Sub Index	Initial value	Data Type	Access	PDO Mapping	Setting Range	Change	Unit
0	0x04	UDINT	RW	No	4	-	-
Store all parameters							
Sub Index	Initial value	Data Type	Access	PDO Mapping	Setting Range	Change	Unit
1	0x0	UDINT	RW	No	0x00000000 to 0xFFFFFFFF F	-	-
Store communication parameters							
Sub Index	Initial value	Data Type	Access	PDO Mapping	Setting Range	Change	Unit
2	0x0	UDINT	RW	No	0x00000000 to 0xFFFFFFFF F	-	-
Store CiA402 parameters							
Sub Index	Initial value	Data Type	Access	PDO Mapping	Setting Range	Change	Unit
3	0x0	UDINT	RW	No	0x00000000 to 0xFFFFFFFF F	-	-
Store L7 specific parameters							
Sub Index	Initial value	Data Type	Access	PDO Mapping	Setting Range	Change	Unit
4	0x0	UDINT	RW	No	0x00000000 to 0xFFFFFFFF F	-	-

- The L7N reads object entries to store parameters.

- In order to prevent parameters from being incorrectly stored, the Sub-Index records a specific "sav" when storing a parameter.

Signature	MSB	16	15	LSB
ASCII	e	v	a	s
Hex	0x65	0x76	0x61	0x73

- All parameters are stored when "sav" is written to Sub-Index 1.
  - Communications are stored when "sav" is written to Sub-Index 2.
  - CiA402 parameters are stored when "sav" is written to Sub-Index 3.
  - L7N parameters are stored when "sav" is written to Sub-Index 4.
- ※ When using this function, delay time will occur by EEPROM save

### 0x1011, Restore Default Parameters

The following table shows the parameters you can reset.

Index 0x1010		Store Parameters					
Number of entries							
Sub Index	Initial value	Data Type	Access	PDO Mapping	Setting Range	Change	Unit
0	0x04	UDINT	RW	No	4	-	-
Restore default parameters							
Sub Index	Initial value	Data Type	Access	PDO Mapping	Setting Range	Change	Unit
1	0x0	UDINT	RW	No	0x00000000 to 0xFFFFFFFF F	-	-
Restore communication default parameters							
Sub Index	Initial value	Data Type	Access	PDO Mapping	Setting Range	Change	Unit
2	0x0	UDINT	RW	No	0x00000000 to 0xFFFFFFFF F	-	-
Restore CiA402 parameters							
Sub Index	Initial value	Data Type	Access	PDO Mapping	Setting Range	Change	Unit
3	0x0	UDINT	RW	No	0x00000000 to 0xFFFFFFFF F	-	-
Restore L7 Specific parameters							
Sub Index	Initial value	Data Type	Access	PDO Mapping	Setting Range	Change	Unit
4	0x0	UDINT	RW	No	0x00000000 to 0xFFFFFFFF F	-	-

- The L7N reads object entries to reset parameters.
- In order to prevent parameters from being incorrectly reset, the Sub-Index records "loa" when the parameter is reset.

Signature	MSB	16	15	LSB
ASCII	d	a	o	l
Hex	0x64	0x61	0x6F	0x6C

- All parameters are reset when "loa" is written to Sub-Index 1.
  - Communication parameters are reset when "loa" is written to Sub-Index 2.
  - CiA402 parameters are reset when "loa" is written to Sub-Index 3.
  - L7N parameters are reset when "loa" is written to Sub-Index 4.
  - Turn the power off and then back on to restore the default values.
- ※ When using this function, delay time will occur to reconnect communication to upper controller by EEPROM call and power on/off

### 0x1018, Identity Object

The following table shows device information.

Index 0x1018		Identity Object					
<b>Number of entries</b>							
Sub Index	Initial value	Data Type	Access	PDO Mapping	Setting Range	Change	Unit
0	4	USINT	RO	No	-	-	-
<b>Vendor ID</b>							
Sub Index	Initial value	Data Type	Access	PDO Mapping	Setting Range	Change	Unit
1	0x00007595	UDINT	RO	No	-	-	-
<b>Product code</b>							
Sub Index	Initial value	Data Type	Access	PDO Mapping	Setting Range	Change	Unit
2	0x0	UDINT	RO	No	-	-	-
<b>Revision number</b>							
Sub Index	Initial value	Data Type	Access	PDO Mapping	Setting Range	Change	Unit
3	0x03	UDINT	RO	No	-	-	-
<b>Serial number</b>							
Sub Index	Initial value	Data Type	Access	PDO Mapping	Setting Range	Change	Unit
4	0x0	UDINT	RO	No	-	-	-

### 8.3 PDO Mapping Objects

You can map objects to Process Data Objects (PDO) when performing real-time data transfers through the CANopen over the EtherCAT protocol.

These objects configure the incoming PDO mapping and outgoing PDO mapping. Information about the mapped application object appears.



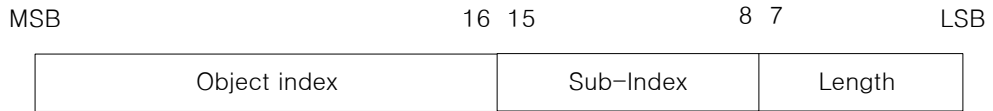

- Bits 0-7: Bit lengths of mapped objects (ex.: 32-bit is displayed as 0x20)
- Bits 8-15: Sub-Indexes of mapped objects
- Bits 16-31: Indexes of mapped objects

### 0x1600 to 0x1603, Receive PDO Mapping

- 1<sup>st</sup> Receive PDO Mapping

Index 0x1600		1st Receive PDO Mapping					
Number of entries							
Sub Index	Initial value	Data Type	Access	PDO Mapping	Setting Range	Change	Unit
0	5	USINT	RW	No	0 to 8	-	-
Mapping entry 1							
Sub Index	Initial value	Data Type	Access	PDO Mapping	Setting Range	Change	Unit
1	0x60400010	UDINT	RW	No	0 to 0xFFFFFFFF	-	-
Mapping entry 2							
Sub Index	Initial value	Data Type	Access	PDO Mapping	Setting Range	Change	Unit
2	0x60710010	UDINT	RW	No	0 to 0xFFFFFFFF	-	-
Mapping entry 3							
Sub Index	Initial value	Data Type	Access	PDO Mapping	Setting Range	Change	Unit
3	0x607A0020	UDINT	RW	No	0 to 0xFFFFFFFF	-	-
Mapping entry 4							
Sub Index	Initial value	Data Type	Access	PDO Mapping	Setting Range	Change	Unit
4	0x60600008	UDINT	RW	No	0 to 0xFFFFFFFF	-	-

Mapping entry 5							
Sub Index	Initial value	Data Type	Access	PDO Mapping	Setting Range	Change	Unit
5	0x60B80010	UDINT	RW	No	0 to 0xFFFFFFFF	-	-

- 2<sup>nd</sup> Receive PDO Mapping

Index 0x1601		2nd Receive PDO Mapping					
Number of entries							
Sub Index	Initial value	Data Type	Access	PDO Mapping	Setting Range	Change	Unit
0	2	USINT	RW	No	0 to 8	-	-

Mapping entry 1

Sub Index	Initial value	Data Type	Access	PDO Mapping	Setting Range	Change	Unit
1	0x60400010	UDINT	RW	No	0 to 0xFFFFFFFF	-	-

Mapping entry 2

Sub Index	Initial value	Data Type	Access	PDO Mapping	Setting Range	Change	Unit
2	0x607A0020	UDINT	RW	No	0 to 0xFFFFFFFF	-	-

- 3<sup>rd</sup> Receive PDO Mapping

Index 0x1602		3rd Receive PDO Mapping					
Number of entries							
Sub Index	Initial value	Data Type	Access	PDO Mapping	Setting Range	Change	Unit

0	2	USINT	RW	No	0 to 8	-	-
Mapping entry 1							
Sub Index	Initial value	Data Type	Access	PDO Mapping	Setting Range	Change	Unit
1	0x60400010	UDINT	RW	No	0 to 0xFFFFFFFF	-	-
Mapping entry 2							
Sub Index	Initial value	Data Type	Access	PDO Mapping	Setting Range	Change	Unit
2	0x60FF0020	UDINT	RW	No	0 to 0xFFFFFFFF	-	-

▪ 4<sup>th</sup> Receive PDO Mapping

Index 0x1603		4th Receive PDO Mapping					
Number of entries							
Sub Index	Initial value	Data Type	Access	PDO Mapping	Setting Range	Change	Unit
0	2	USINT	RW	No	0 to 8	-	-
Mapping entry 1							
Sub Index	Initial value	Data Type	Access	Initial value	Setting Range	Change	Unit
1	0x60400010	UDINT	RW	0x60400010	0 to 0xFFFFFFFF	-	-
Mapping entry 2							
Sub Index	Initial value	Data Type	Access	PDO Mapping	Setting Range	Change	Unit
2	0x60710010	UDINT	RW	No	0 to 0xFFFFFFFF	-	-

**0x1A00 to 0x1A03, Transmit PDO Mapping**

▪ 1<sup>st</sup> Transmit PDO Mapping

Index 0x1A00		1st Transmit PDO Mapping					
Number of entries							
Sub Index	Initial value	Data Type	Access	PDO Mapping	Setting Range	Change	Unit
0	10	USINT	RW	No	0 to 10	-	-
Mapping entry 1							
Sub Index	Initial value	Data Type	Access	PDO Mapping	Setting Range	Change	Unit
1	0x60410010	UDINT	RW	No	0 to 0xFFFFFFFF	-	-
Mapping entry 2							
Sub Index	Initial value	Data Type	Access	PDO Mapping	Setting Range	Change	Unit
2	0x60770010	UDINT	RW	No	0 to 0xFFFFFFFF	-	-
Mapping entry 3							
Sub Index	Initial value	Data Type	Access	PDO Mapping	Setting Range	Change	Unit
3	0x60640020	UDINT	RW	No	0 to 0xFFFFFFFF	-	-
Mapping entry 4							
Sub Index	Initial value	Data Type	Access	PDO Mapping	Setting Range	Change	Unit
4	0x60F40020	UDINT	RW	No	0 to 0xFFFFFFFF	-	-
Mapping entry 5							
Sub Index	Initial value	Data Type	Access	PDO Mapping	Setting Range	Change	Unit
5	0x60FD0020	UDINT	RW	No	0 to 0xFFFFFFFF	-	-
Mapping entry 6							
Sub Index	Initial value	Data Type	Access	PDO Mapping	Setting Range	Change	Unit
6	0x60610008	UDINT	RW	No	0 to	-	-

					0xFFFFFFFF		
Mapping entry 7							
Sub Index	Initial value	Data Type	Access	PDO Mapping	Setting Range	Change	Unit
7	0x26010010	UDINT	RW	No	0 to 0xFFFFFFFF	-	-
Mapping entry 8							
Sub Index	Initial value	Data Type	Access	PDO Mapping	Setting Range	Change	Unit
8	0x26000010	UDINT	RW	No	0 to 0xFFFFFFFF	-	-
Mapping entry 9							
Sub Index	Initial value	Data Type	Access	PDO Mapping	Setting Range	Change	Unit
9	0x60B90010	UDINT	RW	No	0 to 0xFFFFFFFF	-	
Mapping entry 10							
Sub Index	Initial value	Data Type	Access	PDO Mapping	Setting Range	Change	Unit
10	0x60BA0020	UDINT	RW	No	0 to 0xFFFFFFFF	-	

▪ 2<sup>nd</sup> Transmit PDO Mapping

Index 0x1A01		2nd Transmit PDO Mapping					
Number of entries							
Sub Index	Initial value	Data Type	Access	PDO Mapping	Setting Range	Change	Unit
0	2	USINT	RW	No	0 to 10	-	-
Mapping entry 1							

Sub Index	Initial value	Data Type	Access	PDO Mapping	Setting Range	Change	Unit
1	0x60410010	UDINT	RW	No	0 to 0xFFFFFFFF	-	-
<b>Mapping entry 2</b>							
Sub Index	Initial value	Data Type	Access	PDO Mapping	Setting Range	Change	Unit
2	0x60640020	UDINT	RW	No	0 to 0xFFFFFFFF	-	-

- <sup>3r</sup>d Transmit PDO Mapping

Index 0x1A02		3rd Transmit PDO Mapping					
Number of entries							
Sub Index	Initial value	Data Type	Access	PDO Mapping	Setting Range	Change	Unit
0	2	USINT	RW	No	0 to 10	-	-
<b>Mapping entry 1</b>							
Sub Index	Initial value	Data Type	Access	PDO Mapping	Setting Range	Change	Unit
1	0x60410010	UDINT	RW	No	0 to 0xFFFFFFFF	-	-
<b>Mapping entry 2</b>							
Sub Index	Initial value	Data Type	Access	PDO Mapping	Setting Range	Change	Unit
2	0x60640020	UDINT	RW	No	0 to 0xFFFFFFFF	-	-

- <sup>4r</sup>d Transmit PDO Mapping

Index 0x1A03		4th Transmit PDO Mapping					
Number of entries							
Sub Index	Initial value	Data Type	Access	PDO Mapping	Setting Range	Change	Unit
0	2	USINT	RW	No	0 to 10	-	-

Mapping entry 1							
Sub Index	Initial value	Data Type	Access	PDO Mapping	Setting Range	Change	Unit
1	0x60410010	UDINT	RW	No	0 to 0xFFFFFFFF	-	-
Mapping entry 2							
Sub Index	Initial value	Data Type	Access	PDO Mapping	Setting Range	Change	Unit
2	0x60640020	UDINT	RW	No	0 to 0xFFFFFFFF	-	-

## 8.4 Sync Manager Communication Objects

### 0x1C00, Sync Manager Communication Type

Number of entries							
Sub	Initial value	Data	Access	PDO	Setting	Change	Unit

Index		Type		Mapping	Range		
0	4	USINT	RO	No	-	-	-
Communication type sync manager 0							
Sub Index	Initial value	Data Type	Access	PDO Mapping	Setting Range	Change	Unit
1	1: mailbox receive (Master to slave)	USINT	RO	No	-	-	-
Communication type sync manager 1							
Sub Index	Name	Data Type	Access	PDO Mapping	Setting Range	Change	Unit
2	2: mailbox send (Slave to master)	USINT	RO	No	-	-	-
Communication type sync manager 2							
Sub Index	Name	Data Type	Access	PDO Mapping	Setting Range	Change	Unit
3	3: process data output (Master to slave)	USINT	RO	No	-	-	-
Communication type sync manager 3							
Sub Index	Initial value	Data Type	Access	PDO Mapping	Setting Range	Change	Unit
4	4: process data input (Slave to master)	USINT	RO	No	-	-	

### 0x1C10 to 0x1C13, Sync Manager PDO Assignment

This assigns the Sync Manager PDO when the PDO is transmitted through the data communication process.

Index 0x1C10		Sync Manager 0 PDO Assignment					
Sub	Initial value	Data	Access	PDO	Setting	Change	Unit



Index		Type		Mapping	Range		
0	0	USINT	RO	No	-	-	-

Index 0x1C11		Sync Manager 1 PDO Assignment					
Sub Index	Initial value	Data Type	Access	PDO Mapping	Setting Range	Change	Unit
0	0	USINT	RO	No	-	-	-

Index 0x1C12		Sync Manager 2 PDO Assignment					
Number of entries							
Sub Index	Initial value	Data Type	Access	PDO Mapping	Setting Range	Change	Unit
0	1	USINT	RW	No	0 to 2	-	-
Index of assigned RxPDO 1							
Sub Index	Initial value	Data Type	Access	PDO Mapping	Setting Range	Change	Unit
1	0x1601	UINT	RW	No	0x1600 to 0x1603	-	-

Index 0x1C13		Sync Manager 3 PDO Assignment					
Number of entries							
Sub Index	Initial value	Data Type	Access	PDO Mapping	Setting Range	Change	Unit
0	1	USINT	RW	No	0 to 2	-	-

Index of assigned TxPDO 1							
Sub Index	Initial value	Data Type	Access	PDO Mapping	Setting Range	Change	Unit
1	0x1A01	UINT	RW	No	0x1A00 to 0x1A03	-	-

- You can change 0x1C12 and 0x1C13 in the EtherCAT Pre-Operational state.
- Set Sub-Index 1 after Sub-Index 0 is registered as 0.

## 0x1C32, Sync Manager 2 Synchronization

Sync Manager 2 (Process Data Output) Synchronization

Index 0x1C32	Sync Manager 2 (Process Data Output) Synchronization
Number of entries	

Sub Index	Initial value	Data Type	Access	PDO Mapping	Setting Range	Change	Unit
0	10	USINT	RO	No	-	-	-
<b>Synchronization modes</b>							
Sub Index	Initial value	Data Type	Access	PDO Mapping	Setting Range	Change	Unit
1	0: Free-Run	UINT	RO	No	-	-	-
<b>Cycle time</b>							
Sub Index	Initial value	Data Type	Access	PDO Mapping	Setting Range	Change	Unit
2	Time between Sync0 events [ns]	UDINT	RO	No	-	-	-
<b>Shift time</b>							
Sub Index	Initial value	Data Type	Access	PDO Mapping	Setting Range	Change	Unit
3	125000 [ns]	UDINT	RO	No	-	-	-
<b>Synchronization modes supported</b>							
Sub Index	Initial value	Data Type	Access	PDO Mapping	Setting Range	Change	Unit
4	Bit 0 = 1 :Free-Run supported Bit 4:2 = 001 :DC Sync0 supported Bit 6:5 = 00 : No Output Shift supported	UINT	RO	No	-	-	-
<b>Minimum cycle time</b>							
Sub Index	Initial value	Data Type	Access	PDO Mapping	Setting Range	Change	Unit
5	62500 [ns]	UDINT	RO	No	-	-	-
<b>Calc and copy time</b>							
Sub Index	Initial value	Data Type	Access	PDO Mapping	Setting Range	Change	Unit
6	62500 [ns]	UDINT	RO	No	-	-	-
<b>Delay time</b>							

Sub Index	Initial value	Data Type	Access	PDO Mapping	Setting Range	Change	Unit
9	0 [ns]	UDINT	RO	No	-	-	-

**Sync0 time**

Sub Index	Initial value	Data Type	Access	PDO Mapping	Setting Range	Change	Unit
10	same as 1C32:02	UDINT	RO	No	-	-	-

**Cycle exceeded counter**

Sub Index	Initial value	Data Type	Access	PDO Mapping	Setting Range	Change	Unit
11	0	UDINT	RO	No	-	-	-

**Shift too short counter**

Sub Index	Initial value	Data Type	Access	PDO Mapping	Setting Range	Change	Unit
13	-	UDINT	RO	No	-	-	-

**Sync error**

Sub Index	Initial value	Data Type	Access	PDO Mapping	Setting Range	Change	Unit
32	-	BOOL	RO	No	-	-	-

**0x1C33, Sync Manager 3 Synchronization**

Sync Manager 3 (Process Data Input) Synchronization

<b>Index 0x1C33</b>	<b>Sync Manager 3 (Process Data Input) Synchronization</b>
<b>Number of entries</b>	

Sub Index	Initial value	Data Type	Access	PDO Mapping	Setting Range	Change	Unit
0	10	USINT	RO	No		-	-
<b>Synchronization modes</b>							
Sub Index	Initial value	Data Type	Access	PDO Mapping	Setting Range	Change	Unit
1	same as 0x1C32:01	UINT	RO	No		-	-
<b>Cycle time</b>							
Sub Index	Initial value	Data Type	Access	PDO Mapping	Setting Range	Change	Unit
2	same as 0x1C32:02	UDINT	RO	No		-	-
<b>Shift time</b>							
Sub Index	Initial value	Data Type	Access	PDO Mapping	Setting Range	Change	Unit
3	125000*n [ns] (n = 1, 2, 3...) Range: 0 to (Sync0 event cycle time – 125000)	UDINT	RO	No		-	-
<b>Synchronization</b>							
Sub Index	Initial value	Data Type	Access	PDO Mapping	Setting Range	Change	Unit
4	Bit 0 = 1 : Free-Run supported Bit 4:2 = 001 : DC Sync0 supported Bit 6:5 = 01 : Input Shift with local timer supported	UINT	RO	No		-	-

<b>Minimum cycle time</b>							
Sub Index	Initial value	Data Type	Access	PDO Mapping	Setting Range	Change	Unit
5	same as 0x1C32:05	UDINT	RO	No	-	-	-

Calc and copy time							
Sub Index	Initial value	Data Type	Access	PDO Mapping	Setting Range	Change	Unit
6	62500	UDINT	RO	No	-	-	-
Delay time							
Sub Index	Initial value	Data Type	Access	PDO Mapping	Setting Range	Change	Unit
9	0	UDINT	RO	No	-	-	-
Sync0 time							
Sub Index	Initial value	Data Type	Access	PDO Mapping	Setting Range	Change	Unit
10	same as 0x1C32:10	UDINT	RO	No		-	-
SM event missed count							
Sub Index	Initial value	Data Type	Access	PDO Mapping	Setting Range	Change	Unit
12	-	UDINT	RO	No	-	-	-
Shift too short counter							
Sub Index	Initial value	Data Type	Access	PDO Mapping	Setting Range	Change	Unit
13	-	UDINT	RO	No	-	-	-
Sync error							
Sub Index	Initial value	Data Type	Access	PDO Mapping	Setting Range	Change	Unit
14	-	BOOL	RO	No	-	-	-

## 8.5 Manufacturer Specific Objects

### 0x2000, Motor ID

This specifies the motor ID.

Index 0x2000		Motor ID					
Sub Index	Initial value	Data Type	Access	PDO Mapping	Setting Range	Change	Unit
0	999	UINT	RW	No	0 to 999	PRECYC	-

In the case of Serial encoder, automatically set.  
But, for multi turn encoder, need to set manually

### 0x2001, Encoder Type

This specifies the current encoder type.

Index 0x2001		Encoder Type					
Sub Index	Initial value	Data Type	Access	PDO Mapping	Setting Range	Change	Unit
0	0	UINT	RW	No	0 to 5	PRECYC	-

Value	Encoder Type	value	Encoder Type
1	Single turn serial encoder	3	Mult iturn serial encoder

The encoder data is read to display the encoder type.

### 0x2002, Encoder Resolution

This specifies the encoder bits read for automatic display.

Index 0x2002		Encoder Resolution					
Sub Index	Initial value	Data Type	Access	PDO Mapping	Setting Range	Change	Unit
0	19	UINT	RW	No	0 to 21	PRECYC	[bit]

In the case of Serial encoder, automatically set.  
But, for multi turn encoder, need to set manually

### 0x2003, Power Fail Mode

This specifies the main power input mode and the processing mode to use if phase loss occurs.

Index 0x2003		Power Fail Mode					
Sub Index	Initial value	Data Type	Access	PDO Mapping	Setting Range	Change	Unit
0	0b000	UINT	RW	No	0b00 to 0b11	SV_OFF	-

- Details

Bit	function	Value (Hex)	Setting details
0	Set the main power input type	0	Single-phase power input
		1	Three-phase power input
1	How to handle phase loss on the main power	0	Display Error in case of phase loss on the main power.
		1	Display Warning in case of phase loss on the main power.

### 0x2004, RST Power Fail Check Time

This specifies the monitoring interval when main power phase loss occurs.

Index 0x2004		RST Power Fail Check Time					
Sub Index	Initial value	Data Type	Access	PDO Mapping	Setting Range	Change	Unit
0	20	UINT	RW	No	0 to 5000	Always	ms

### 0x2005, 7SEG Display Object

This specifies the 7SEG display objects.

Index 0x2005		7SEG Display Object					
Sub Index	Initial value	Data Type	Access	PDO Mapping	Setting Range	Change	Unit
0	0	UINT	RW	Yes	2600 to 2616	Always	-

- Can specify the objects applied when the servo turns on.
- There are 617 values available from Index 0x2600 to 0x2616. Choose one for the specific parameter.

### 0x2006, Regenerative Resistor De-rating Factor

This specifies the derating factor which checks for regenerative resistance overloads. If the derating value is 100% or less, then the overload alarm trigger time is proportional to the set value.



Index 0x2006		Regenerative Resistor De-rating Factor					
Sub Index	Initial value	Data Type	Access	PDO Mapping	Setting Range	Change	Unit
0	100	UINT	RW	No	0 to 200	SV_OFF	[%]

### 0x2007, Regenerative Resistor Value

This specifies the resistance value for regenerative braking resistance. If it is set to 0, then it uses the default resistance capacity embedded in the drive.

Index 0x2007		Regenerative Resistor Value					
Sub Index	Initial value	Data Type	Access	PDO Mapping	Setting Range	Change	Unit
0	0	UINT	RW	No	0 to 1000	PRECYC	ohm

### 0x2008, Regenerative Resistor Capacity

This specifies the current capacity for regenerative resistance. If it is set to 0, then it uses the default resistance capacity embedded in the drive.

Index 0x2008		Regenerative Resistor Capacity					
Sub Index	Initial value	Data Type	Access	PDO Mapping	Setting Range	Change	Unit
0	0	UINT	RW	No	0 to 30000	PRECYC	Watt

### 0x2009, Overload Check Base

This indicates the load factor which triggers a continuous overload check. If it is set to 100 or less, then the overload check starts early and the overload alarm triggers early.

Index 0x2009		Overload Check Base					
Sub Index	Initial value	Data Type	Access	PDO Mapping	Setting Range	Change	Unit
0	100	UINT	RW	No	10 to 100	SV_OFF	[%]

### 0x200A, Overload Warning Level

This specifies the level for the continuous overload warning signal output. The warning signal is issued when it reaches the percentage value set relative to the alarm trigger value.

Index 0x200A		Overload Warning Level					
Sub	Initial value	Data	Access	PDO	Setting	Change	Unit

Index 0x200A		Overload Warning Level					
Index		Type		Mapping	Range		
0	50	UINT	RW	Yes	10 to 100	SV_OFF	[%]

### 0x200B, PWM Off Delay

This specifies the time span between the servo Off command and actual PWM Off. This prevents the motor from slipping down the vertical axis while the servo Off command and brake command order the motor brake to engage. Use a PWM off delay when operating a motor brake through the output contact point brake signal. (range: 0-1000 ms, initial value: 10).

Index 0x200B		PWM Off Delay					
Sub Index	Initial value	Data Type	Access	PDO Mapping	Setting Range	Change	Unit
0	10	UINT	RW	No	0 to 1000	10	ms

### 0x200C, Dynamic Brake Control Mode

This specifies the Dynamic Brake (DB) control mode.

Index 0x200C		Dynamic Brake Control Mode					
Sub Index	Initial value	Data Type	Access	PDO Mapping	Setting Range	Change	Unit
0	0x0	UINT	RW	No	0x0 to 0x3	SV_OFF	-

#### ▪ Details

Value	Setting details
0	Hold after a DB stop
1	Release after a DB stop
2	Release after free run stop
3	Hold after a free run stop

### 0x200D, Basic Function Configuration

This specifies the basic drive function.

Index 0x200D		Basic Function Configuration					
Sub	Initial value	Data	Access	PDO	Setting	Change	Unit

Index 0x200D		Basic Function Configuration					
Index		Type		Mapping	Range		
0	0x00	UINT	RW	No	0x00 to 0xFF	SV_OFF	-

▪ **Details**

Bit	function	Value (Hex)	Setting details
0	Sets the servo drive direction	0	CCW (Clockwise), CW (Counterclockwise)
		1	CW (Clockwise), CCW (Counterclockwise)
1	Sets the servo lock function	0	Do not use
		1	Use
4	Set the multi-turn encoder	0	Use the multi-turn encoder as multi-turn
		1	Use the multi-turn encoder as single-turn

**0x200E, Position Scale Numerator**

Index 0x200E		Position Scale Numerator					
Sub Index	Initial value	Data Type	Access	PDO Mapping	Setting Range	Change	Unit
0	1	INT	RW	No	1 ~ 32767	SV_OFF	-

**0x200F, Position Scale Denominator**

Index 0x200F		Position Scale Denominator					
Sub Index	Initial value	Data Type	Access	PDO Mapping	Setting Range	Change	Unit
0	1	INT	RW	No	1 ~ 32767	SV_OFF	-

**0x2010, Velocity Scale Numerator**

Index 0x2010		Velocity Scale Numerator					
Sub Index	Initial value	Data Type	Access	PDO Mapping	Setting Range	Change	Unit
0	1	INT	RW	No	1 ~ 32767	SV_OFF	-

**0x2011, Velocity Scale Denominator**

Index 0x2011		Velocity Scale Denominator					
Sub Index	Initial value	Data Type	Access	PDO Mapping	Setting Range	Change	Unit
0	1	INT	RW	No	1 ~ 32767	SV_OFF	-

**0x2012, Acceleration Scale Numerator**

Index 0x2012		Acceleration Scale Numerator					
Sub Index	Initial value	Data Type	Access	PDO Mapping	Setting Range	Change	Unit
0	1	INT	RW	No	1 ~ 32767	SV_OFF	-

**0x2013, Acceleration Scale Denominator**

Index 0x2013		Acceleration Scale Denominator					
Sub Index	Initial value	Data Type	Access	PDO Mapping	Setting Range	Change	Unit
0	1	INT	RW	No	1 ~ 32767	SV_OFF	-

**■ 0x2014, DAC Output**

Index 0x2014		DAC Output					
Number of entries							
Sub Index	Initial value	Data Type	Access	PDO Mapping	Setting Range	Change	Unit
0	9	USINT	RO	No	0 to 9	Always	-

Output Mode							
Sub Index	Initial value	Data Type	Access	PDO Mapping	Setting Range	Change	Unit
1	0x3210	UINT	RW	No	0x0000 to 0xFFFF	Always	-
Channel 1 offset							
Sub Index	Initial value	Data Type	Access	PDO Mapping	Setting Range	Change	Unit
2	0	INT	RW	No	-32768 to 32767	Always	Unit/V
Channel 2 offset							
Sub Index	Initial value	Data Type	Access	PDO Mapping	Setting Range	Change	Unit
3	0	INT	RW	No	-32768 to 32767	Always	Unit/V
Channel 3 offset							
Sub Index	Initial value	Data Type	Access	PDO Mapping	Setting Range	Change	Unit
4	0	INT	RW	No	-32768 to 32767	Always	Unit/V
Channel 4 offset							
Sub Index	Initial value	Data Type	Access	PDO Mapping	Setting Range	Change	Unit
5	0	INT	RW	No	-32768 to 32767	Always	Unit/V
Channel 1 Scale							
Sub Index	Initial value	Data Type	Access	PDO Mapping	Setting Range	Change	Unit
6	0	UINT	RW	No	0 to 65535	Always	Unit/V
Channel 2 Scale							
Sub Index	Initial value	Data Type	Access	PDO Mapping	Setting Range	Change	Unit
7	500	UINT	RW	No	0 to 65535	Always	Unit/V
Channel 3 Scale							

Sub Index	Initial value	Data Type	Access	PDO Mapping	Setting Range	Change	Unit
8	50	UINT	RW	No	0 to 65535	Always	Unit/V
Channel 4 Scale							
Sub Index	Initial value	Data Type	Access	PDO Mapping	Setting Range	Change	Unit
9	50	UINT	RW	No	0 to 65535	Always	Unit/V

▪ **Details**

There are 4 DAC Output available and send out data according to setting with 200[usec] cycle time.

▪ **DAC Output Type**

Type	Data	Type	Data
0	Speed Feedback[RPM]	5	Following Error[pulse]
1	Speed Command[RPM]	6	DC Link Voltage[V]
2	Torque Feedback[%]	D	Speed Command(User)[RPM]
3	Torque Command[%]	E	Torque Command(User)[RPM]
4	Position Command Frequency[0.1kpps]		

▪ **DAC Output Offset**

Set Offset[Unit/V] for analog output channel1~4.

(Speed[RPM], Torque[%], Position Command Frequency[0.1kpps], Position[pulse], DC\_Link[V])

▪ **DAC Output Scale**

If value of output is too low or high, output rate can be adjusted to high or low.

Set scale[Unit/V] of analog output channel1~4.

(Speed[RPM], Torque[%], Position Command Frequency[0.1kpps], Position[pulse], DC\_Link[V])

Ex) 1channel scale 100 => Output 1[V] when 100[RPM].

**0x2015, U Phase Current Offset**

Set value of U Phase current offset. Value of current offset is already set in factory.

If you do not know the correct settings, don't set manually.

Index 0x2015		U Phase Current Offset					
Sub Index	Initial value	Data Type	Access	PDO Mapping	Setting Range	Change	Unit
0	-	INT	RW	No	-10000 ~ 10000	SV_OFF	[mA]

### 0x2016, V Phase Current Offset

Set value of V Phase current offset. Value of current offset is already set in factory.

If you do not know the correct settings, don't set manually.

Index 0x2016		V Phase Current Offset					
Sub Index	Initial value	Data Type	Access	PDO Mapping	Setting Range	Change	Unit
0	V Phase Current Offset	INT	RW	No	-10000 ~ 10000	SV_OFF	[mA]

### 0x2017, W Phase Current Offset

Set value of W Phase current offset. Value of current offset is already set in factory.

If you do not know the correct settings, don't set manually.

Index 0x2016		W Phase Current Offset					
Sub Index	Initial value	Data Type	Access	PDO Mapping	Setting Range	Change	Unit
0	-	INT	RW	No	-10000 ~ 10000	-	[mA]

### 0x2100, Inertia Ratio Setting

This sets the inertia ratio by calculating the load inertia from the machine system and rotor inertia listed on the motor specification table.

Index 0x2100		Inertia Ratio					
Sub Index	Initial value	Data Type	Access	PDO Mapping	Setting Range	Change	Unit
0	100	UINT	RW	No	0 to 20000	Always	[%]

The inertia/load ratio is an important control parameter for the operation of the servo. It is crucial to set the correct inertia ratio for optimal servo operation.

### 0x2101, Position P Gain 1

Index 0x2101		Position P Gain 1					
Sub Index	Initial value	Data Type	Access	PDO Mapping	Setting Range	Change	Unit
0	50	UINT	RW	No	0 to 500	Always	Hz

### 0x2102, Position P Gain 2

Index 0x2102		Position P Gain 2					
Sub Index	Initial value	Data Type	Access	PDO Mapping	Setting Range	Change	Unit
0	70	UINT	RW	No	0 to 500	Always	Hz

- Position proportional gain [0x2101] and [0x2102]: Converts the difference between the position command and the current position into a speed command by multiplying it by the position proportional gain.

\* Recommended value = speed proportional gain [0x2106]/10

### 0x2103, The Position Command Filter Time Constant

Index 0x2103		Position Command Filter Time Constant					
Sub Index	Initial value	Data Type	Access	PDO Mapping	Setting Range	Change	Unit
0	0	UINT	RW	No	0 to 1000	Always	ms

### 0x2104, Position Feed-forward Gain

Index 0x2104		Position Feed-forward Gain					
Sub Index	Initial value	Data Type	Access	PDO Mapping	Setting Range	Change	Unit
0	0	UINT	RW	No	0 to 100	Always	[%]

- Feed-forward gain [0x2104]: Uses the differences in value to the position command to calculate the gradient. Adds the speed command to the gradient to reduce the time needed to reach the target position. If the value which results is too large, then the position controller may overshoot or become unstable. It is important to gradually increase the value from a small value while monitoring the test drive.



### 0x2105, The Position Feed-forward Filter Time Constant

Index 0x2105		Position Feed-forward Filter Time Constant					
Sub Index	Initial value	Data Type	Access	PDO Mapping	Setting Range	Change	Unit
0	0	UINT	RW	No	0 to 1000	Always	ms

- The feed-forward filter time constant [0x2105]: The feed-forward control filter vibrates if the position command changes too drastically. If this occurs, configure the filter value until the vibrations disappear.

### 0x2106, Speed P Gain 1

Index 0x2106		Speed P Gain 1					
Sub Index	Initial value	Data Type	Access	PDO Mapping	Setting Range	Change	Unit
0	400	UINT	RW	No	0 to 5000	Always	rad/s

### 0x2107, Speed P Gain 2

Index 0x2107		Speed P Gain 2					
Sub Index	Initial value	Data Type	Access	PDO Mapping	Setting Range	Change	Unit
0	700	UINT	RW	No	0 to 5000	Always	rad/s

- Speed proportional gain [0x2106] and [0x2107]: Converts the speed error into a torque command by multiplying it by the proportional gain.

### 0x2108, Speed Integral Time Constant 1 (Speed I Gain 1 Time Constant)

Index 0x2108		Speed I Gain 1 Time Constant					
Sub Index	Initial value	Data Type	Access	PDO Mapping	Setting Range	Change	Unit
0	50	UINT	RW	No	1 to 1000	Always	ms

### 0x2109, Speed Integral Time Constant 2 (Speed I Gain 2 Time Constant)

Index 0x2109		Speed I Gain 2 Time Constant					
Sub Index	Initial value	Data Type	Access	PDO Mapping	Setting Range	Change	Unit
0	15	UINT	RW	No	1 to 1000	Always	ms

- Speed integral time constants [0x2108] and [0x2109]: Calculates the integral value of the speed error. The speed error is the difference between the command speed and the current speed. The speed integral time constant converts the speed error into a torque command by multiplying it by the integral time constant.

### 0x210A, The Speed Command Filter Time Constant

Index 0x210A		Speed Command Filter Time Constant					
Sub Index	Initial value	Data Type	Access	PDO Mapping	Setting Range	Change	Unit
0	0	UINT	RW	No	0 to 1000	Always	ms

### 0x210B, The Speed Feedback Filter Time Constant

Index 0x210B		Speed Feedback Filter Time Constant					
Sub Index	Initial value	Data Type	Access	PDO Mapping	Setting Range	Change	Unit
0	5	UINT	RW	No	0 to 1000	Always	0.1ms

- Speed feedback filter time constant [0x210B]: Filters the speed feedback to control vibrations when the speed of the motor changes due to drive system vibrations or vibrations due to gain and too much load inertia.

### 0x210C, The Torque Command Filter Time Constant

Use a digital filter for the analog torque command voltage to improve the stability of command signals. If the filter value is set too high, responsiveness to torque commands will be reduced. It is important to set a value that is appropriate for your system.

Index 0x210C		Torque Command Filter Time Constant					
Sub Index	Initial value	Data Type	Access	PDO Mapping	Setting Range	Change	Unit
0	0	UINT	RW	No	0 to 1000	Always	ms

## 0x210D, Conversion Mode

Index 0x210D		Conversion Mode					
Sub Index	Initial value	Data Type	Access	PDO Mapping	Setting Range	Change	Unit
0	0x00	UINT	RW	No	0x00 to 0xFF	Always	-

### 1. Set the gain transfer mode.

- **Details**

Bit	function	Value (Hex)	Setting details
0 to 3	Gain 1<->Gain 2 Conversion Setting	0	Only uses gain 1.
		1	ZSPD auto gain transfer In case of zero speed, transfer from gain 1 to gain 2. In the opposite case, transfer from gain 2 to gain 1.
		2	INPOS auto gain transfer In case of IN position, transfer from gain 1 to gain 2. In the opposite case, transfer from gain 2 to gain 1.
		3	Manual gain transfer When the gain 2 contact is on, transfer from gain 1 to gain 2. In the opposite case, transfer from gain 2 to gain 1.

### 2. Setting the P and PI Control Conversion Modes

- **Details**

Bit	function	Value (Hex)	Setting details
4 to 7	Set the P<->PI conversion	0	Only control PI.
		1	Control P if the command torque is higher than the set torque [0x2114].
		2	Control P if the command speed is higher than the set speed [0x2115].
		3	Control P if the current acceleration is higher than the set torque [0x2116].
		4	Control P if the current position error is higher than the set position error [0x2117].

**Note 1)** Control P if the PCON contact is on (highest priority).

- These functions allow you to improve position operations by applying the P control operation stop function after PI control operation.

### 0x210E, The Gain Conversion Time

- This sets the gain conversion time during gain conversion operation.

Index 0x210E		Gain Conversion Time					
Sub Index	Initial value	Data Type	Access	PDO Mapping	Setting Range	Change	Unit
0	1	UINT	RW	No	1 to 100	Always	ms

- When converting gain 1 to gain 2 or gain 2 to gain 1, the conversion occurs according to the set time.

### 0x210F, The Resonance Avoidance Operation (Notch Filter Use)

Index 0x210F		Notch Filter Use					
Sub Index	Initial value	Data Type	Access	PDO Mapping	Setting Range	Change	Unit
0	0	UINT	RW	No	0 to 1	Always	-

Mechanical resonance causes vibrations to occur at certain frequencies in certain systems. You can control the vibrations by controlling the torque output for specific frequencies.

- Details

Bit	function	Value (Hex)	Setting details
0 to 3	Resonance avoidance operation	0	Do not use
		1	Use

### 0x2110, The Resonance Avoidance Frequency (Notch Filter Frequency)

Index 0x2110		Notch Filter Frequency					
Sub Index	Initial value	Data Type	Access	PDO Mapping	Setting Range	Change	Unit
0	300	UINT	RW	No	0 to 1000	Always	-

### 0x2111, The Resonance Avoidance Range (Notch Filter Bandwidth)

Index 0x2111		Notch Filter Bandwidth					
Sub Index	Initial value	Data Type	Access	PDO Mapping	Setting Range	Change	Unit

Index 0x2111		Notch Filter Bandwidth					
0	100	UINT	RW	No	0 to 1000	Always	-

### 0x2112, The Velocity Limit Switch

Index 0x2112		Velocity Limit Switch					
Sub Index	Initial value	Data Type	Access	PDO Mapping	Setting Range	Change	Unit
0	0	UINT	RW	No	0 to 3	Always	-

### 0x2113, The Velocity Limit Value

Index 0x2113		Velocity Limit Value					
Sub Index	Initial value	Data Type	Access	PDO Mapping	Setting Range	Change	Unit
0	2000	UINT	RW	No	0 to 10000	Always	RPM

### 0x2114, P Control Conversion Torque (Torque Switch Value)

Index 0x2114		Torque Switch Value					
Sub Index	Initial value	Data Type	Access	PDO Mapping	Setting Range	Change	Unit
0	200	UINT	RW	No	0 to 300	Always	[%]

### 0x2115, The P Control Conversion Speed (Speed Switch Value)

Index 0x2115		Speed Switch Value					
Sub Index	Initial value	Data Type	Access	PDO Mapping	Setting Range	Change	Unit
0	50	UINT	RW	No	0 to 6000	Always	[RPM]

### 0x2116, P Control Conversion Acceleration (Acceleration Switch Value)

Index 0x2116		Acceleration Switch Value					
Sub Index	Initial value	Data Type	Access	PDO Mapping	Setting Range	Change	Unit
0	100	UINT	RW	No	0 to 5000	Always	rpm/s

### 0x2117, P Control Conversion Position Error (Following Error Switch Value)

Index 0x2117		Following Error Switch Value					
Sub Index	Initial value	Data Type	Access	PDO Mapping	Setting Range	Change	Unit
0	2000	UINT	RW	No	0 to 10000	Always	Pulse

### 0x2200, Input Port Define 1

Index 0x2200		Input Port Define 1					
Sub Index	Initial value	Data Type	Access	PDO Mapping	Setting Range	Change	Unit
0	0x4000	UINT	RW	No	0x0000 to 0xFFFF	PRECYC	-

### 0x2201, Input Port Define 2

Index 0x2201		Input Port Define 2					
Sub Index	Initial value	Data Type	Access	PDO Mapping	Setting Range	Change	Unit
0	0x0065	UINT	RW	No	0x0000 to 0xFFFF	PRECYC	-

### 0x2202, Output Port Define 1

Index 0x2202		Output Port Define 1					
Sub Index	Initial value	Data Type	Access	PDO Mapping	Setting Range	Change	Unit
0	0x4321	UINT	RW	No	0x0000 to 0xFFFF	PRECYC	-

### 0x2203, Output Port Define 2

Index 0x2203		Output Port Define 2					
Sub Index	Initial value	Data Type	Access	PDO Mapping	Setting Range	Change	Unit
0	0x0	UINT	RW	No	0x0000 to 0xFFFF	PRECYC	-

### 0x2204, The Input Port Logic Set

Index 0x2204		Input Port Logic Set					
Sub Index	Initial value	Data Type	Access	PDO Mapping	Setting Range	Change	Unit
0	0b111111	UINT	RW	No	0b0000000000 to 0b1111111111	PRECYC	-

### 0x2205, The Output Port Logic Set

Index 0x2205		Output Port Logic Set					
Sub Index	Initial value	Data Type	Access	PDO Mapping	Setting Range	Change	Unit
0	0b0110	UINT	RW	No	0b0000000000 to 0b1111111111	PRECYC	-

### 0x2206, The Zero Speed Range

Index 0x2206		Zero Speed Range					
Sub Index	Initial value	Data Type	Access	PDO Mapping	Setting Range	Change	Unit
0	10	UINT	RW	No	1 to 65535	Always	RPM

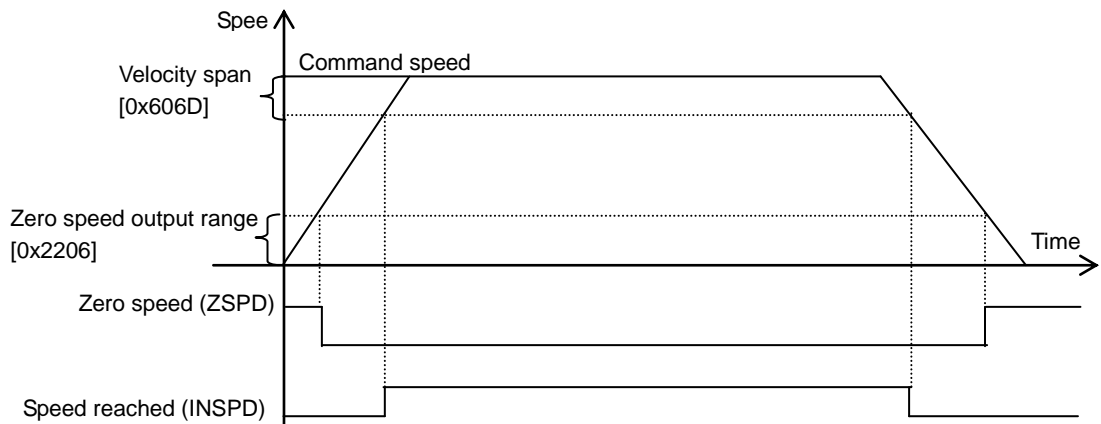

- Zero speed output range [0x2206]: A zero speed signal is output if the current speed drops below the set speed.
- Speed-reached range [0x606D]: The speed-reached signal is output.

### 0x2207, The Break Output Speed

Index 0x2207		Break Output Speed					
Sub Index	Initial value	Data Type	Access	PDO Mapping	Setting Range	Change	Unit
0	100	UINT	RW	No	1 to 6000	Always	RPM

### 0x2208, The Break Output Delay Time

Index 0x2208		Break Output Delay Time					
Sub Index	Initial value	Data Type	Access	PDO Mapping	Setting Range	Change	Unit
0	500	UINT	RW	No	0 to 1000	Always	ms

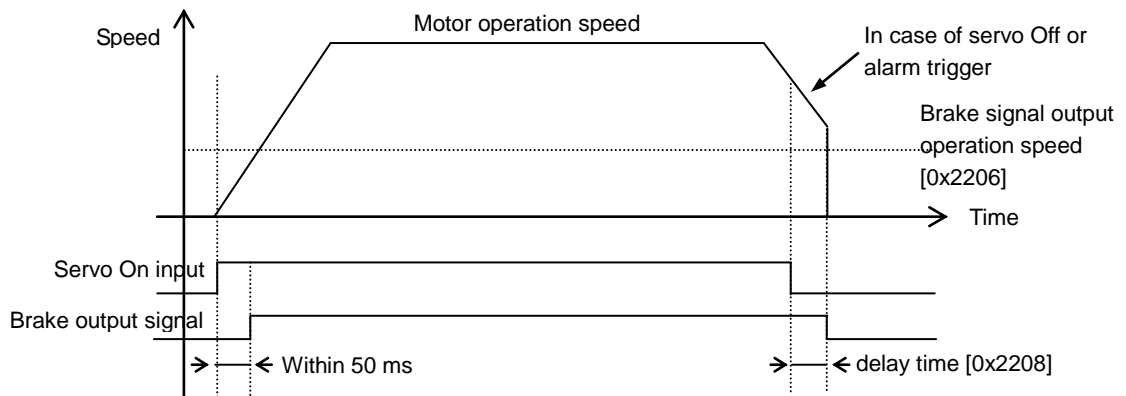

- The brake signal output operation speed [0x2207] and brake signal output delay time [0x2208]

If an alarm occurs after the servo's built-in brake is applied to the vertical axis for motor operation, then this feature activates to prevent the load on the vertical axis from falling to the motor brake. This may occur as a result of the brake signal turning off because of the brake signal output operation speed [0x2206] or the brake signal output delay time [0x2207].

### 0x2300, The Index (Z-phase) Pulse Detection Operation Speed (Index Pulse Search Speed)

Index 0x2300		Index Pulse Search Speed					
Sub Index	Initial value	Data Type	Access	PDO Mapping	Setting Range	Change	Unit
0	10	UINT	RW	No	1 to 300	Always	RPM

### 0x2301, The Speed Command Acceleration Time

Index 0x2301		Speed Command Acceleration Time					
Sub Index	Initial value	Data Type	Access	PDO Mapping	Setting Range	Change	Unit
0	0	UINT	RW	No	0 to 10000	Always	ms

- Acceleration time [0x2301]: Specifies the time required, in ms, for the motor to reach the rated motor speed from zero speed.



### 0x2302, The Speed Command Deceleration Time

Index 0x2302		Speed Command Deceleration Time					
Sub Index	Initial value	Data Type	Access	PDO Mapping	Setting Range	Change	Unit
0	0	UINT	RW	No	0 to 10000	Always	ms

- Deceleration time [0x2302]: Specifies the time, in ms, required for the motor to stop after running at the rated motor speed.

### 0x2303, The Speed Command S-curve Time

Index 0x2303		Speed Command S-curve Time					
Sub Index	Initial value	Data Type	Access	PDO Mapping	Setting Range	Change	Unit
0	10	UINT	RW	No	1 to 100	Always	ms

### 0x2304, The Speed Operation Pattern (Acceleration Pattern)

Index 0x2304		Acceleration Pattern					
Sub Index	Initial value	Data Type	Access	PDO Mapping	Setting Range	Change	Unit
0	0	UINT	RW	No	0 to 1	Always	-

You can configure the acceleration/deceleration operation in an S-curve pattern for smooth acceleration/deceleration.

- Details

Value	Setting details
0	Trapezoidal -> Configure the acceleration/deceleration time in [0x2301] and [0x2302]
1	Sinusoidal -> Configure the acceleration/deceleration time [0x2301] and [0x2302] + S-curve time [0x2303]

### 0x2305, The Manual JOG Operation Speed (JOG Speed)

Index 0x2305		JOG Speed					
Sub Index	Initial value	Data Type	Access	PDO Mapping	Setting Range	Change	Unit
0	500	INT	RW	No	-6000 to 6000	Always	RPM

**0x2306, JOG Operation Speed 1 (Program JOG Speed 1)**

Index 0x2306		Program JOG Speed 1					
Sub Index	Initial value	Data Type	Access	PDO Mapping	Setting Range	Change	Unit
0	0	INT	RW	No	-6000 to 6000	Always	RPM

**0x2307, JOG Operation Speed 2 (Program JOG Speed 2)**

Index 0x2307		Program JOG Speed 2					
Sub Index	Initial value	Data Type	Access	PDO Mapping	Setting Range	Change	Unit
0	3000	INT	RW	No	-6000 to 6000	Always	RPM

**0x2308, JOG Operation Speed 3 (Program JOG Speed 3)**

Index 0x2308		Program JOG Speed 3					
Sub Index	Initial value	Data Type	Access	PDO Mapping	Setting Range	Change	Unit
0	0	INT	RW	No	-6000 to 6000	Always	RPM

**0x2309, JOG Operation Speed 4 (Program JOG Speed 4)**

Index 0x2309		Program JOG Speed 4					
Sub Index	Initial value	Data Type	Access	PDO Mapping	Setting Range	Change	Unit
0	-3000	INT	RW	No	-6000 to 6000	Always	RPM

**0x230A, JOG Operation Time 1 (Program JOG Time 1)**

Index 0x230A		Program JOG Time 1					
Sub Index	Initial value	Data Type	Access	PDO Mapping	Setting Range	Change	Unit
0	500	UINT	RW	No	0 to 65535	Always	ms

**0x230B, JOG Operation Time 2 (Program JOG Time 2)**

Index 0x230B		Program JOG Time 2					
Sub Index	Initial value	Data Type	Access	PDO Mapping	Setting Range	Change	Unit

Index 0x230B		Program JOG Time 2					
0	5000	UINT	RW	No	0 to 65535	Always	ms

### 0x230C, JOG Operation Time 3 (Program JOG Time 3)

Index 0x230C		Program JOG Time 3					
Sub Index	Initial value	Data Type	Access	PDO Mapping	Setting Range	Change	Unit
0	500	UINT	RW	No	0 to 65535	Always	ms

### 0x230D, JOG Operation Time 4 (Program JOG Time 4)

A test drive repeats step 1 to 4.

Set the operation speed ([0x2306]-[0x2309]) and operation time ([0x230A]-[0x230D]) for each step.

Index 0x230D		Program JOG Time 4					
Sub Index	Name	Data Type	Access	PDO Mapping	Setting Range	Change	Unit
0	5000	UINT	RW	No	0 to 65535	Always	ms

### 0x2402, The Position Limit Function

Index 0x2402		Position Limit Function					
Sub Index	Initial value	Data Type	Access	PDO Mapping	Setting Range	Change	Unit
0	0	UINT	RW	No	0 to 1	Always	-

- Details

Value(Hex)	Setting details
0	Checking Software Position Limit value of forward direction
1	Checking Software Position Limit value of reverse direction

### 0x2403, Backlash Compensation

If the position operation causes backlashes which change the position, then this setting converts backlash amount into a number of pulses to compensate for the backlash.

Index 0x2403		Backlash Compensation					
Sub Index	Initial value	Data Type	Access	PDO Mapping	Setting Range	Change	Unit
0	0	UINT	RW	No	0 to 10000	Always	-

### 0x2600, The Current Speed (RPM)

This displays the current operation speed in RPM.

Index 0x2600		Current Speed (RPM)					
Sub Index	Initial value	Data Type	Access	PDO Mapping	Setting Range	Change	Unit
0	-	INT	RO	Yes	-	-	RPM

### 0x2601, The Command Speed (RPM)

This displays the current command speed in RPM.

Index 0x2601		Command Speed (RPM)					
Sub Index	Initial value	Data Type	Access	PDO Mapping	Setting Range	Change	Unit
0	-	INT	RO	Yes	-	-	RPM

### 0x2602, The Tracking Position Pulse (Feedback Pulse)

This displays the accumulated number of position command pulses that result from servo motor rotations when the servo turned on.

Index 0x2602		Feedback Pulse					
Sub Index	Initial value	Data Type	Access	PDO Mapping	Setting Range	Change	Unit
0	-	DINT	RO	No	-	-	Pulse

### 0x2603, The Position Command Pulse

This displays the accumulated number of position command pulses entered since the servo turned on.

Index 0x2603		Command Pulse					
Sub Index	Initial value	Data Type	Access	PDO Mapping	Setting Range	Change	Unit
0	-	DINT	RO	No	-	-	Pulse

### 0x2604, The Remaining Position Pulse (Following Error)

This displays the difference between command pulses and tracking pulses and the remaining position pulses for the servo to run.

It ignores the remaining position pulses when a servo that is off is turned back on.

Index 0x2604		Following Error					
Sub Index	Initial value	Data Type	Access	PDO Mapping	Setting Range	Change	Unit
0	0	DINT	RO	Yes	-	-	Pulse

### 0x2605, The Input Command Frequency

This displays the input pulse frequency.

Index 0x2605		Input Command Frequency					
Sub Index	Initial value	Data Type	Access	PDO Mapping	Setting Range	Change	Unit
0	0	INT	RO	No	-	-	KHz

### 0x2606, Current Operation Torque

This displays the energy (load) output by the servo motor as a percentage of the rated output.

Index 0x2606		Current Torque					
Sub Index	Initial value	Data Type	Access	PDO Mapping	Setting Range	Change	Unit
0	0	INT	RO	No	-	-	[%]

### 0x2607, Current Command Torque

This uses the serv's control algorithm to calculate the internal torque command and display it as a percentage of the rated torque.

Index 0x2607		Command Torque					
Sub Index	Initial value	Data Type	Access	PDO Mapping	Setting Range	Change	Unit
0	0	INT	RO	No	-	-	[%]

### 0x2608, Accumulated Overload

This displays the current energy (load) as a percentage of the rated energy (load) of the servo motor.

Index 0x2608		Accumulated Overload					
Sub Index	Initial value	Data Type	Access	PDO Mapping	Setting Range	Change	Unit
0	0	INT	RO	Yes	-	-	[%]

### 0x2609, The Maximum Instantaneous Load

This displays the maximum (peak) load between the current time and the start of control after the servo turns on as a percentage of the rated output.

Index 0x2609		Maximum Load					
Sub Index	Initial value	Data Type	Access	PDO Mapping	Setting Range	Change	Unit
0	0	INT	RO	No	-	-	[%]

### 0x260A, The Torque Limit

This displays the maximum torque that the servo motor can output as a percentage of the rated torque.

Index 0x260A		Torque Limit					
Sub Index	Initial value	Data Type	Access	PDO Mapping	Setting Range	Change	Unit
0	-	INT	RO	No	-	-	[%]

### 0x260B, The DC-Link Voltage

This displays the current DC link value of the main power.

The normal DC link voltage of a 220 V standard drive is approximately 300 V. The maximum allowable DC link voltage is 405 V.

The overvoltage alarm [AL-41] goes off when the DC link voltage threshold is exceeded because there is either too much or too little regenerative resistance.

The normal DC link voltage in the regenerative section is 385 V or below.

Index 0x260B		DC-Link Voltage					
Sub Index	Initial value	Data Type	Access	PDO Mapping	Setting Range	Change	Unit
0	0	UINT	RO	Yes	-	-	V

### 0x260C, Regenerative Overload

This displays the overload rate relative to the regenerative capacity of the servo drive.

Index 0x260C		Regenerative Overload					
Sub Index	Initial value	Data Type	Access	PDO Mapping	Setting Range	Change	Unit
0	0	UINT	RO	Yes	-	-	[%]

### 0x260D, The Single-turn Data (Pulse) Display (Single-turn Data)

This displays the single-turn data of the encoder in pulses.

Index 0x260D		Single-turn Data					
Sub Index	Initial value	Data Type	Access	PDO Mapping	Setting Range	Change	Unit
0	0	DINT	RO	Yes	-	-	Pulse

### 0x260E, The Single-turn Data (Degree) Display (Single-turn Data (deg))

This displays the single-turn data of the encoder in degrees.

Index 0x260E		Single-turn Data (deg)					
Sub Index	Initial value	Data Type	Access	PDO Mapping	Setting Range	Change	Unit
0	0	UINT	RO	Yes	-	-	Degrees

### 0x260F, The Multi-turn Data Display

This displays the multi-turn data for the encoder.

Index 0x260F		Multi-turn Data					
Sub Index	Initial value	Data Type	Access	PDO Mapping	Setting Range	Change	Unit
0	0	INT	RO	Yes	-	-	rev

### 0x2610, The Room Temperature Display

This displays the temperature sensor value of the servo drive in [°C].

Index 0x2610		Room temperature					
Sub Index	Initial value	Data Type	Access	PDO Mapping	Setting Range	Change	Unit
0	0	UINT	RO	No	-	-	[°C]

### 0x2611, The Motor Rated Speed Display

This displays the rated speed of the motor in RPM.

Index 0x2611		Motor Rated Speed					
Sub Index	Initial value	Data Type	Access	PDO Mapping	Setting Range	Change	Unit
0	0	UINT	RO	No	-	-	RPM

### 0x2612, The Motor Maximum Speed Display

This displays the peak speed of the motor in RPM.

Index 0x2612		Motor Maximum Speed					
Sub Index	Initial value	Data Type	Access	PDO Mapping	Setting Range	Change	Unit
0	0	UINT	RO	No	-	-	RPM

### 0x2613, The Motor Rated Current Display

This displays the rated current of the motor in A.

Index 0x2613		Motor Rated Current					
Sub Index	Initial value	Data Type	Access	PDO Mapping	Setting Range	Change	Unit

Index 0x2613		Motor Rated Current					
0	0	UINT	RO	No	-	-	A

### 0x2614, The U Phase Current Offset Display

This displays the U phase current offset in mA.

Index 0x2614		U Phase Current Offset					
Sub Index	Initial value	Data Type	Access	PDO Mapping	Setting Range	Change	Unit
0	0	INT	RO	No	-	-	mA

### 0x2615, The V Phase Current Offset Display

This displays the V phase current offset in mA.

Index 0x2615		V Phase Current Offset					
Sub Index	Initial value	Data Type	Access	PDO Mapping	Setting Range	Change	Unit
0	0	INT	RO	No	-	-	mA

### 0x2616, The FPGA Version Display

This displays the version of the FPGA.

Index 0x2616		FPGA Version					
Sub Index	Initial value	Data Type	Access	PDO Mapping	Setting Range	Change	Unit
0	-	UINT	RO	No	-	-	-

### 0x2617, External Encoder Position Feedback

Index 0x2617		External Encoder Position Feedback					
Sub Index	Initial value	Data Type	Access	PDO Mapping	Setting Range	Change	Unit
0	-	DINT	RO	Yes	-	-	[rev]

### 0x2618, External Encoder Following Error

Display Following pulse difference between Internal and External encoder.

Index 0x2618		External Encoder Following Error					
--------------	--	----------------------------------	--	--	--	--	--



Sub Index	Initial value	Data Type	Access	PDO Mapping	Setting Range	Change	Unit
0	-	DINT	RO	Yes	-	-	[rev]

### 0x2700, Read/Clear the Alarm History

Index 0x2700		Read/Clear Alarm History					
Number of entries							
Sub Index	Initial value	Data Type	Access	PDO Mapping	Setting Range	Change	Unit
0	21	USINT	RO	No	-	-	-
Clear History							
Sub Index	Initial value	Data Type	Access	PDO Mapping	Setting Range	Change	Unit
1	0	UDINT	RW	No	-	-	-
Alarm Code 1~20							
Sub Index	Initial value	Data Type	Access	PDO Mapping	Setting Range	Change	Unit
2~21	0	USINT	RO	No	-	-	-

- The L7N reads object entries to determine the alarm history of a parameter.
- In order to prevent parameters from being incorrectly read, the Sub-Index records "read" when the parameter is read.

Signature	MSB	16	15	LSB
ASCII	d	a	e	r
Hex	0x64	0x61	0x65	0x72

- The L7N reads object entries to delete the alarm history of a parameter.
- In order to prevent parameters from being incorrectly deleted, record "rset" in the Sub-Index and an alarm history is deleted.

Signature	MSB	16	15	LSB
ASCII	t	e	s	r
Hex	0x74	0x65	0x73	0x72

- When "read" is written to Sub-Index 1, all 20 alarm histories are read.
- When "rset" is written to Sub-Index 1, all 20 alarm histories are deleted.
- Alarm codes 1 to 20 is from 0x2700: 02 to 0x2700: 21.
- The first alarm code is the most recent alarm.

You can check the past 20 alarm codes in sequence (the most recent first), by reading Sub-Indexes 2 to 21.

### 0x2701, Auto Gain Tuning (Auto-tuning)

Index 0x2701		Auto-tuning					
Number of entries							
Sub Index	Initial value	Data Type	Access	PDO Mapping	Setting Range	Change	Unit
0	3	USINT	RO	No	-	SV_OFF	-
Start tuning							
Sub Index	Initial value	Data Type	Access	PDO Mapping	Setting Range	Change	Unit
1	0	UDINT	RW	No	-	SV_OFF	-
Tuning speed							
Sub Index	Initial value	Data Type	Access	PDO Mapping	Setting Range	Change	Unit
2	8	UINT	RW	No	1 to 10	SV_OFF	100 [RPM]
Tuning distance							
Sub Index	Initial value	Data Type	Access	PDO Mapping	Setting Range	Change	Unit
3	3	UINT	RW	No	1 to 5	SV_OFF	-

- The L7N reads object entries to automatically tune the gain.
- In order to prevent parameters from being incorrectly tuned, the parameter is only tuned when the Sub-Index records "tune."

Signature	MSB	16	15	LSB
ASCII	e	n	u	t
hex	0x65	0x6E	0x75	0x74

- Automatic tuning is conducted when "tune" is written to the Sub-Index 1.
- This should be performed when the servo is off.
- When writing "tune," the function begins to operate and repeats three times based on the set speed and distance parameters.
- Automatic gain tuning changes the inertia ratio (0x2100), speed proportional gain 1 (0x2106), and speed integral time constant 1 (0x2108).

- Set the automatic gain tuning speed in Sub-Index 2.
- The default value is 8 in \*100 RPM units.
- Set the automatic gain tuning distance in Sub-Index 3.
- It rotates 1.2 to 1.4 turns for motor shafts with a default value of 3, and about 25% of the distance increases or decreases when the setting value is increased or decreased by 1.

It estimates the inertia based on the speed set in Sub-Index 2 and the distance set in Sub-Index 3. It stores the inertia ratio [0x2100], speed proportional gain 1 [0x2106], and speed proportional gain 2 [0x2108].

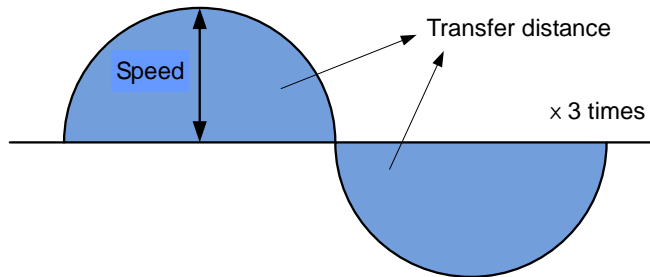

### 0x2702, Reset Absolute Encoder

Index 0x2702		Reset Absolute Encoder					
Reset Absolute Encoder							
Sub Index	Initial value	Data Type	Access	PDO Mapping	Setting Range	Change	Unit
0	1	USINT	RW	No	-	PRECYC	-
Reset Encoder							
Sub Index	Initial value	Data Type	Access	PDO Mapping	Setting Range	Change	Unit
1	0	UDINT	RW	No	-	PRECYC	-

### 0x2703, Calibrate Current Offset

Index 0x2703		Calibrate Current Offset					
Calibrate Current Offset							
Sub Index	Initial value	Data Type	Access	PDO Mapping	Setting Range	Change	Unit
0	1	USINT	RW	No	-	PRECYC	-
Calibrate Offset							
Sub Index	Initial value	Data Type	Access	PDO Mapping	Setting Range	Change	Unit
1	0	UDINT	RW	No	-	PRECYC	-

L7N offers calibration-function for current offset.

Sifnature	MSB	16	15	LSB
ASCII	t	e	s	r
hex	0x74	0x65	0x73	0x72

Current Offset will be calibrated by writing "rset" in Sub-Index 1.

## 8.6 CiA402 Objects

### 0x603F, Error Code

This displays the most recent alarm/warning code generated by the servo drive.

Index 0x603F		Error Code					
Sub Index	Initial value	Data Type	Access	PDO Mapping	Setting Range	Change	Unit
0	0	UINT	RO	Yes	-	-	-

### 0x6040, Controlword

This is composed of bits which control the drive state, the operation mode, and manufacturer-specific options.

Index 0x6040		Controlword					
Sub Index	Initial value	Data Type	Access	PDO Mapping	Setting Range	Change	Unit
0	0	UINT	RW	Yes	0 to 0xFFFF	Always	-

▪ Controlword Bit

Bit	function	Details
0	Switch on	Refer to the section concerning bits 0 to 3.
1	Enable Voltage	
2	Quick stop	
3	Enable operation	
4 to 6	Settings by operation mode	Refer to the section concerning bits 4 to 9.
7	Fault reset	0-> 1: Alarm/warning reset
8	Halt	Refer to the section concerning bits 4 to 9.
9	Settings by operation mode	
10	-	-
11 to 15	-	-

### Details on Bits 0 to 3

▪ Bits 0 to 3: Drive state control

Command	Controlword Bit				
	Bit 7	Bit 3	Bit 2	Bit 1	Bit 0
Shutdown	0	-	1	1	0
Switch on	0	0	1	1	1
Switch on + Enable operation	0	1	1	1	1
Disable voltage	0	-	-	0	-
Quick stop	0	-	0	1	-
Disable operation	0	0	1	1	1
Enable operation	0	1	1	1	1

## Details on Bits 4 to 9

- Bits 4, 5 and 9: Applied in Profile position (Pp) mode

Bit 9	Bit 5	Bit 4	Details
0	0	0 → 1	It proceeds to the next position when the operation at the current position is complete.
–	1	0 → 1	It drives to the next position immediately.
1	0	0 → 1	It drives from the current position to the profile position at the profile speed before it applies the next position.

- Bits 6 and 8: Applied in Profile position (Pp) mode

Bit	function	Value	Details
6	Abs/rel	0	Sets the target position to an absolute value.
		1	Sets the target position to a relative value.
8	Halt	0	Runs an operation or continues an operation.
		1	Halts the operation according to the Halt Option code (0x605D).

- Bits 4, 5, 6, 8 and 9: Applied in Homing mode

Bit	function	Value	Details
4	Homing operation start	0	Does not perform the homing operation.
		1	Performs or is performing the homing operation.
5	–	0	-
6	–	0	-
8	Halt	0	Runs the bit 4 command.
		1	Halts the operation according to the Halt Option code (0x605D).
9	–	0	Reserved

- Bits 4, 5, 6, 8 and 9: Applied in Cyclic synchronous position (Csp) mode, velocity mode, or torque mode.

Bit	function	Value	Details
4	–	0	-
5	–	0	-
6	–	0	-
8	Halt	0	Continues to perform the operation.
		1	Halts the operation according to the Halt Option code (0x605D).
9	–	0	-

- Bits 4, 5, 6, 8 and 9: Applied at the Interpolated position (Ip)

Bit	Function	Value	Details
4	Interpolation	0	Interpolation disabled

Bit	Function	Value	Details
	enabled	1	Interpolation enabled
5	–	0	-
6	–	0	-
8	Halt	0	Runs the bit 4 command.
		1	Halts the operation according to the Halt Option code (0x605D).
9	–	0	Reserved

- Bits 4, 5, 6, 8 and 9: Applied in Profile velocity (Pv) mode or torque mode

Bit	function	Value	Details
4	–	0	Reserved
5	–	0	Reserved
6	–	0	Reserved
8	Halt	0	Continues to perform the operation.
		1	Halts the operation according to the Halt Option code (0x605D).
9	–	0	Reserved

### 0x6041, Statusword

The Statusword indicates the current state of the drive.

It consists of bits that indicate the state according to the drive and operation mode.

Index 0x6041		Statusword					
Sub Index	Initial value	Data Type	Access	PDO Mapping	Setting Range	Change	Unit
0	0	UINT	RO	Yes	0 to 0xFFFF	-	-

- Statusword Bits

Bit	Function	Details
0	Ready to switch on	Refer to the section concerning bits 0 to 7.
1	Switched on	
2	Operation enabled	
3	Fault	
4	Voltage enabled	
5	Quick stop	
6	Switch on disabled	
7	Warning	
8	–	Reserved
9	Remote	Processed as a Controlword (0x6040)
10	Operation mode specific	Refer to the sections concerning bits 10, 12 and 13.
11	Internal limit active	Refer to the section concerning bit 11.
12 to 13	Operation mode specific	Refer to the sections concerning bits 10, 12 and 13.
14	Torque limit active	= 0; no torque limit active = 1; torque limit active
15	–	Reserved

### ■ Details on Bits 0 to 7

- Bits 0 to 7: Indicates the current state of the drive

Bit 7	Bit 6	Bit 5	Bit 4	Bit 3	Bit 2	Bit 1	Bit 0	Drive State
–	0	–	–	0	0	0	0	Not ready to switch on
–	1	–	–	0	0	0	0	Switch on disabled
–	0	1	–	0	0	0	1	Ready to switch on
–	0	1	–	0	0	1	1	Switched on
–	0	1	–	0	1	1	1	Operation enabled
–	0	0	–	0	1	1	1	Quick stop active
–	0	–	–	1	1	1	1	Fault reaction active



Bit 7	Bit 6	Bit 5	Bit 4	Bit 3	Bit 2	Bit 1	Bit 0	Drive State
-	0	-	-	1	0	0	0	Fault
-	-	-	1	-	-	-	-	Main Power On
1	-	-	-	-	-	-	-	Warning is occurred

■ **Details about Bit 11**

- Bit 11: Indicates whether to use an internal limit

Use of an internal limit: Both the software position limit and internal limit are applied to the target position.

Use N-OT/P-OT contacts

This exceeds the interpolation speed (only used for the interpolated position (Ip) or the cyclic synchronous position (Csp))

■ **Details on Bits 10, 12 and 13**

- Bits 10, 12 and 13: Profile position (Pp) Mode

Bit	State	Value	Details
10	Target reached	0	Halt (0x6040.8) = 0: Failed to reach the target position Halt (0x6040.8) = 1: Deceleration
		1	Halt (0x6040.8) = 0: Reached the target position Halt (0x6040.8) = 1: Speed: 0
12	Set-point acknowledge	0	Prepares the previous set point and waits for a new set point

Bit	State	Value	Details
		1	Changed from the previous set point to the new set point
13	Following error	0	No following error
		1	Following error

- Bits 10, 12 and 13: Homing Mode

Bit 13	Bit 12	Bit 10	Details
Homing error	Homing attained	Target reached	
0	0	0	Homing in progress
0	0	1	Homing stopped or not started
0	1	0	Performed homing operation, but the not reach the target
0	1	1	Homing completed
1	0	0	Homing error; speed not equal to 0
1	0	1	Homing error; speed equal to 0

- Bits 10, 12 and 13: Cyclic synchronous position (Csp)/velocity mode/torque mode

Bit	State	Value	Details
10	Target reached	0	Unable to reach the target (position/velocity/torque)
		1	Reached the target (position/velocity/torque)
12	Target value ignored	0	Ignores the target value (position/velocity/torque)
		1	Uses the target value as the position control input
13	Following error	0	No following error (0 in Csv/constant in torque mode)
		1	Following error

- Bits 10, 12 and 13: Interpolated position (Ip) mode

Bit	State	Value	Details
10	Target reached	0	Halt (0x6040.8) = 0: Unable to reach the target position Halt (0x6040.8) = 1: Deceleration
		1	Halt (0x6040.8) = 0: Reached the target position Halt (0x6040.8) = 1: Speed: 0
12	Ip mode active	0	Interpolation deactivated
		1	Interpolation activated

13	–	0	-
10	Target reached	0	Halt (0x6040.8) = 0: Unable to reach the target position Halt (0x6040.8) = 1: Deceleration

- Bits 10, 12 and 13: Profile velocity (Pv) mode

Bit	State	Value	Details
10	Target reached	0	Halt (0x6040.8) = 0: Unable to reach the target position Halt (0x6040.8) = 1: Deceleration
		1	Halt (0x6040.8) = 0: Reached the target position Halt (0x6040.8) = 1: Speed: 0
12	Speed	0	Not in a zero speed state
		1	In zero a speed state
13	–	0	-

- Bits 10, 12 and 13: Profile torque (Pt) mode

Bit	State	Value	Details
10	Target reached	0	Halt (0x6040.8) = 0: Failed to reach the target position Halt (0x6040.8) = 1: Deceleration
		1	Halt (0x6040.8) = 0: Reached the target position Halt (0x6040.8) = 1: Speed: 0
12	–	0	Reserved
13	–	0	Reserved

### 0x605A, The Quick Stop Option Code

This sets the Quick Stop option code.

Index 0x605A		Quick Stop Option Code					
Sub Index	Initial value	Data Type	Access	PDO Mapping	Setting Range	Change	Unit
0	2	INT	RW	No	0 to 4	-	-

- Details

Value	Details
0	Not used (transits into Switch On Disabled).
1	Slowly decelerates and then stops the drive according to the quick stop deceleration (0x6085) setting (Switch On Disabled).
2	Slowly decelerates and then stops the drive according to the quick stop deceleration (0x6085) setting (Switch On Disabled).
3	Stops using the torque limit value (Switch On Disabled).

### 0x605B, The Shutdown Option Code

This specifies the operation to shutdown the servo drive (Operation Enabled state -> Ready to Switch On state).

Index 0x605B		Shutdown Option Code					
Sub Index	Initial value	Data Type	Access	PDO Mapping	Setting Range	Change	Unit
0	0	INT	RW	No	0 to 1	Always	-

- Details

Value	Details
0	Not used
1	Decelerates to a stop; enters a Switch On Disabled state; enters a Ready state

### 0x605C, The Disable Operation Option Code

This sets the Disable Operation state (Operation Enabled state -> Switched On state) option code.

Index 0x605C		Disable Operation Option Code					
Sub Index	Initial value	Data Type	Access	PDO Mapping	Setting Range	Change	Unit
0	1	INT	RW	No	0 to 1	Always	-

- Details

Value	Details
0	Does not use the drive function
1	Decelerates to a stop; moves to the Switch On Disabled state; moves to the Not Ready state

### 0x605D, The Halt Option Code

The Halt option code sets the operation method used to move from the Operation Enabled state to the Switched On state.

Index 0x605D		Halt Option Code					
Sub Index	Initial value	Data Type	Access	PDO Mapping	Setting Range	Change	Unit
0	0	INT	RW	No	0 to 4	Always	-

- Details

Value	Details
1	Decelerates to a stop; moves to the Operation Enabled state
2	Decelerates to a stop based on the quick stop deceleration time; move to the Operation Enabled state
3	Decelerates to a stop based on the torque limit; moves to the Operation Enabled state

### 0x605E, The Fault Reaction Option Code

This sets the operation method which protects the L7N drive system during fault reactions.

Index 0x605D		Fault Reaction Option Code					
Sub Index	Initial value	Data Type	Access	PDO Mapping	Setting Range	Change	Unit
0	0	INT	RW	No	0	Always	-

- Details

Value	Details
-------	---------

Value	Details
0	Does not use the servo drive function. The motor maintains the free-run state (turns the servo Off).

## 0x6060, Modes of Operation

This sets the servo drive operation mode. The master sets the operation mode when the power is turned on.

The L7N provides the following operation modes:

Index 0x6060		Modes of Operation					
Sub Index	Initial value	Data Type	Access	PDO Mapping	Setting Range	Change	Unit
0	0	SINT	RW	Yes	0 to 10	Always	-

### ▪ Details

Value	Name	Details
0	-	No mode change/no mode assigned
1	Pp	Profile Position mode
2	-	Reserved (keep last mode)
3	Pv	Profile Velocity mode
4	Tq	Profile Torque mode
6	Hm	Homing mode
7	Ip	Interpolated Position mode
8	Csp	Cyclic Sync Position mode
9	Csv	Cyclic Sync Velocity mode
10	Cst	Cyclic Sync Torque mode
Other	-	Reserved (keep last mode)

## 0x6061, The Modes of Operation Display

This displays the current mode of operation.

The value displayed is identical to the operation mode (0x6060).

Index 0x6061		Modes of Operation Display					
Sub Index	Initial value	Data Type	Access	PDO Mapping	Setting Range	Change	Unit
0	0	SINT	RO	Yes	0 to 10	-	-

### 0x6062, The Position Demand Value

This displays the position demand value in the position units specified by the user.

Index 0x6062		Position Demand Value					
Sub Index	Initial value	Data Type	Access	PDO Mapping	Setting Range	Change	Unit
0	0	DINT	RO	Yes	-	-	Pos. unit

### 0x6063, The Position Actual Internal Value

This displays the actual internal position value in encoder pulses.

Index 0x6063		Position Actual Internal Value					
Sub Index	Initial value	Data Type	Access	PDO Mapping	Setting Range	Change	Unit
0	0	DINT	RO	Yes	-	-	Pulse

### 0x6064, The Position Actual Value

This displays the actual position value in user-defined units.

Index 0x6064		Position Actual Value					
Sub Index	Initial value	Data Type	Access	PDO Mapping	Setting Range	Change	Unit
0	0	DINT	RO	Yes	-	-	Pos. unit

### 0x6065, The Position Error Range (Following Error Window)

This sets the position error range for the Following Error (Statusword, 0x6041.13).

Index 0x6065		Following Error Window					
Sub Index	Initial value	Data Type	Access	PDO Mapping	Setting Range	Change	Unit
0	2000000	UDINT	RW	No	0 to 1073741823	Always	Pos. unit

### 0x6066, Position Error Timeout (Following Error Time Out)

This sets the position error timeout period.

Index 0x6066		Following Error Time Out					
Sub Index	Initial value	Data Type	Access	PDO Mapping	Setting Range	Change	Unit
0	0	UINT	RW	No	0 to 65535	Always	ms

### 0x6067, The Position Reached Range (Position Window)

This sets the position reached range for the target.

If the L7N reaches the position window (0x6067) within the position window time (0x6068), then it sets bit 10 of the Statusword (0x6041) to 1.

Index 0x6067		Position Window					
Sub Index	Initial value	Data Type	Access	PDO Mapping	Setting Range	Change	Unit
0	100	UDINT	RW	No	0 to 1073741823	Always	Pos. unit

### 0x6068, The Position Reached Time (Position Window Time)

This sets the time it takes to reach the target position.

If the L7N reaches the position window (0x6067) within the position window time (0x6068), then it sets bit 10 of the Statusword (0x6041) to 1.

Index 0x6068		Position Window Time					
Sub Index	Initial value	Data Type	Access	PDO Mapping	Setting Range	Change	Unit
0	0	UINT	RW	No	0 to 65535	Always	ms

### 0x606B, The Velocity Demand Value

This displays the position controller output or the trajectory generator output speed.

Index 0x606B		Velocity Demand Value					
Sub Index	Initial value	Data Type	Access	PDO Mapping	Setting Range	Change	Unit
0	0	DINT	RO	Yes	-	-	Vel. unit

### 0x606C, The Actual Velocity Value

This displays the actual velocity value in user-defined position units.



Index 0x606C		Actual Velocity Value					
Sub Index	Initial value	Data Type	Access	PDO Mapping	Setting Range	Change	Unit
0	0	DINT	RO	Yes	-	-	Vel. unit

### 0x606D, The Velocity Reached Range (Velocity Window)

This sets the range of the velocity window.

If the difference between the target velocity and the actual velocity is retained within the velocity window range (0x606D) for the duration of the velocity window time (0x606E), then it sets bit 10 of Statusword (0x6041) to 1.

This displays the window in user-defined units.

Index 0x606D		Velocity Window					
Sub Index	Initial value	Data Type	Access	PDO Mapping	Setting Range	Change	Unit
0	20000	UINT	RW	No	0 to 65535	Always	Vel. unit

### 0x606E, The Velocity Window Time

This sets the velocity window time.

If the difference between the target velocity and the actual velocity is retained within the velocity window range (0x606D) for the duration of the velocity window time (0x606E), then it sets bit 10 of Statusword (0x6041) to 1.

Index 0x606E		Velocity Window Time					
Sub Index	Initial value	Data Type	Access	PDO Mapping	Setting Range	Change	Unit
0	0	UINT	RW	No	0 to 65535	Always	ms

### 0x6071, The Target Torque

This displays the target torque for the motor in 0.1% increments of the rated torque.

Index 0x6071		Target Torque					
Sub Index	Initial value	Data Type	Access	PDO Mapping	Setting Range	Change	Unit
0	0	INT	RW	Yes	-32768 to +32767	Always	[0.1%]

### 0x6072, Maximum Torque

This sets the maximum torque that the motor can output in 0.1% increments of the rated torque.

This is the default maximum motor torque when power is first supplied to the servo drive.

Index 0x6072		Max. Torque					
Sub Index	Initial value	Data Type	Access	PDO Mapping	Setting Range	Change	Unit
0	3000	UINT	RW	Yes	0 to 65535	Always	[0.1%]

### 0x6074, The Torque Demand Value

This displays the current torque demand value in 0.1% increments of the rated torque.

Index 0x6074		Torque Demand Value					
Sub Index	Initial value	Data Type	Access	PDO Mapping	Setting Range	Change	Unit
0	0	INT	RO	Yes	-	Always	[0.1%]

### 0x6076, The Motor Rated Torque

This displays the rated torque of the motor (mNm).

Index 0x6076		Motor Rated Torque					
Sub Index	Initial value	Data Type	Access	PDO Mapping	Setting Range	Change	Unit
0	0	UDINT	RO	No		Always	mNm

### 0x6077, The Torque Actual Value

This displays the actual torque value of the L7N in 0.1% increments of the rated torque.

Index 0x6077		Torque Actual Value					
Sub Index	Initial value	Data Type	Access	PDO Mapping	Setting Range	Change	Unit
0	0	INT	RO	Yes	-	-	[0.1%]

### 0x607A, The Target Position

This sets the target position in Profile Position (Pp) mode and Cyclic Synchronous Position (Csp) mode.

This position is applied as an abs/rel flag of the Controlword in Profile Position (Pp) mode according to absolute/relative value setting. It is always applied as an absolute value in Csp mode.

Index 0x607A		Target Position					
Sub Index	Initial value	Data Type	Access	PDO Mapping	Setting Range	Change	Unit
0	1310720	DINT	RW	Yes	-2147483648 to +2147483647	Always	-

### 0x607C, The Home Offset

This sets the offset value for the origin of the absolute encoder or absolute external scale and the zero position of the actual position value (0x6064).

Index 0x607C		Home Offset					
Sub Index	Initial value	Data Type	Access	PDO Mapping	Setting Range	Change	Unit
0	0	DINT	RW	No	- 536870912 to +536870911	Always	Pos. unit

- Incremental encoder

If it finds the home position or it is at the home position, then the position moved by the home offset value becomes the zero position.

- Absolute encoder

If the absolute encoder is connected, then the home offset value is added to the absolute position (the actual position value).

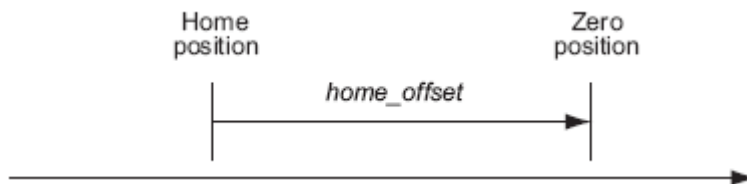

### 0x607D, The Software Position Limit

This sets the software limit value.

It limits the range of the position demand value (0x6062) and position actual value (0x6064) and checks the new target positions for these ranges every time.

The software limit value is always relative to the mechanical origin.

The minimum software limit value is the reverse rotation limit. The maximum software limit value is the forward rotation limit.

Index 0x607D	Software Position Limit
Number of entries	

Sub Index	Initial value	Data Type	Access	PDO Mapping	Setting Range	Change	Unit
0	2	DINT	RW	No	–	Always	-
Min. position limit							
Sub Index	Initial value	Data Type	Access	PDO Mapping	Setting Range	Change	Unit
1	-2000000000	DINT	RW	No	-536870912 to 536870911	Always	[Pos. unit]
Max. position limit							
Sub Index	Initial value	Data Type	Access	PDO Mapping	Setting Range	Change	Unit
2	2000000000	DINT	RW	No	-536870912 to 536870911	Always	[Pos. unit]

### 0x607F, Maximum Profile Velocity

This sets the maximum profile velocity in profile mode.

Index 0x607F		Max. Profile Velocity					
Sub Index	Initial value	Data Type	Access	PDO Mapping	Setting Range	Change	Unit
0	2147483647	UDINT	RW	Yes	0 to 4294967295	Always	Vel. unit

### 0x6081, The Profile Velocity

This sets the profile velocity in profile mode.

Index 0x6081		Profile Velocity					
Sub Index	Initial value	Data Type	Access	PDO Mapping	Setting Range	Change	Unit
0	10000	UDINT	RW	Yes	0 to 21474836474	Always	Vel. unit

### 0x6083, Profile Acceleration

This sets the acceleration in profile mode.

Index 0x6083	Profile Acceleration
--------------	----------------------

Index 0x6083		Profile Acceleration					
Sub Index	Initial value	Data Type	Access	PDO Mapping	Setting Range	Change	Unit
0	20000	UDINT	RW	No	0 to 21474836474	Always	Acc. unit

### 0x6084, Profile Deceleration

This sets the deceleration in profile mode.

Index 0x6084		Profile Deceleration					
Sub Index	Initial value	Data Type	Access	PDO Mapping	Setting Range	Change	Unit
0	20000	UDINT	RW	No	0 to 21474836474	Always	Acc. unit

### 0x6085, Quick Stop Deceleration

The system uses quick stop deceleration if the quick stop option code (0x605A) is set to 2.

Index 0x6085		Quick Stop Deceleration					
Sub Index	Initial value	Data Type	Access	PDO Mapping	Setting Range	Change	Unit
0	100000	UDINT	RW	No	0 to 21474836474	Always	Acc. unit

### 0x6087, The Torque Slope

This sets the torque slope in profile torque mode. It adjusts the rated torque per second in 0.1% increments.

Index 0x6087		Torque Slope					
Sub Index	Initial value	Data Type	Access	PDO Mapping	Setting Range	Change	Unit
0	1000	UDINT	RW	Yes	0 to 21474836474	Always	0.1%/s

### 0x6098, The Homing Method

This sets the homing method. Refer to section 5.4, "Homing."

Index 0x6098		Homing Method					
Sub Index	Initial value	Data Type	Access	PDO Mapping	Setting Range	Change	Unit
0	34	SINT	RW	Yes	0 to 35	Always	-

- Details

Value	Details
0	Disabled
1	Homing using the index pulse and reverse limit contact

Value	Details
2	Homing using the index pulse and forward limit contact
7 to 14	Homing using the index pulse and home contact
24	Same as method 8 (does not use the index pulse)
28	Same as method 12 (does not use the index pulse)
33, 34	Homing to the index pulse
35	Homing to the current position

### 0x6099, Homing Speeds

This sets the homing speed in user-defined units.

Index 0x6099		Homing Speeds					
Number of entries							
Sub Index	Initial value	Data Type	Access	PDO Mapping	Setting Range	Change	Unit
0	2	UDINT	RO	No	-	-	-
Speed during search for switch							
Sub Index	Initial value	Data Type	Access	PDO Mapping	Setting Range	Change	Unit
1	100000	UDINT	RW	Yes	0 to 4294967295	Always	[Vel. unit]
Speed during search for zero							
Sub Index	Initial value	Data Type	Access	PDO Mapping	Setting Range	Change	Unit
2	20000	UDINT	RW	Yes	0 to 4294967295	Always	[Vel. unit]

Setting value equation:  $X = (\text{Pulses per revolution}) * \text{Setting speed (RPM)} / 60$

Ex) 19bit motor 3000 [RPM]setting  $X = 2^{19} * 3000 / 60 \rightarrow X = 26214400$

### 0x609A, Homing Acceleration

This sets the homing acceleration in user-defined units.

Index 0x609A		Homing Acceleration					
Sub Index	Initial value	Data Type	Access	PDO Mapping	Setting Range	Change	Unit
0	50000	UDINT	RW	No	0 to 4294967295	Always	Acc. unit

Setting value equation:  $X = (\text{Pulses per revolution}) * \text{Setting acceleration speed} / 60$

Ex) 19bit motor acceleration 3000 setting  $X = 2^{19} * 3000 / 60 \rightarrow X = 26214400$

### 0x60B1, The Velocity Offset

This sets the speed feed-forward value in Cyclic Synchronous Position (Csp) mode.

This also sets the offset value added to the speed reference in Cyclic Synchronous Position (Csp) mode.

Index 0x60B1		Velocity Offset					
Sub Index	Initial value	Data Type	Access	PDO Mapping	Setting Range	Change	Unit
0	0	DINT	RW	Yes	-2147483648 to +2147483647	Always	Vel. unit

### 0x60B2, The Torque Offset

This sets the torque feed-forward value in Cyclic Synchronous Position (Csp) mode and Cyclic Synchronous Velocity (Csv) mode. It also sets the offset value added to the torque reference.

Index 0x60B2		Torque Offset					
Sub Index	Initial value	Data Type	Access	PDO Mapping	Setting Range	Change	Unit
0	0	INT	RW	Yes	-32768 to +32767	Always	[0.1%]

### 0x60B8, The Touch Probe Function

This sets the touch probe function.

Index 0x60B8		Touch Probe Function					
Sub Index	Initial value	Data Type	Access	PDO Mapping	Setting Range	Change	Unit
0	51	UINT	RW	Yes	0 to 0xFFFF	Always	-

- Data Description

Bit	Value	Definition
0	0	Do not use touch probe 1.
	1	Use touch probe 1.
1	0	Single trigger mode (latch at the first trigger event of the touch probe)
	1	Continuous trigger mode (latch at the trigger event for each position of the touch probe)
2	0	Trigger the input of touch probe 1.
	1	Trigger the index pulse signal.
3	-	Reserved
4	0	Do not use sampling for the rising edge of touch probe 1.

Bit	Value	Definition
5	1	Use sampling for the rising edge of touch probe 1.
	0	Do not use sampling for the falling edge of touch probe 1.
	1	Use sampling for the falling edge of touch probe 1.
6 to 7	–	Reserved
8	0	Do not use touch probe 2.
	1	Use touch probe 2.
9	0	Single trigger mode (latch at the first trigger event of the touch probe)
	1	Continuous trigger mode (latch at the trigger event for each position of the touch probe)
10	0	Trigger the input of touch probe 2.
	1	Trigger the index pulse signal.
11	–	Reserved
12	0	Do not use sampling for the rising edge of touch probe 2.
	1	Use sampling for the rising edge of touch probe 2.
13	0	Do not use sampling for the rising edge of touch probe 2.
	1	Use sampling for the rising edge of touch probe 2.
14 to 15	–	Reserved

### 0x60B9, The Touch Probe Status

This displays the status of the touch probe.

Index 0x60B8		Touch Probe Status					
Sub Index	Initial value	Data Type	Access	PDO Mapping	Setting Range	Change	Unit
0	0	UINT	RO	Yes	–	-	-

#### ▪ Data Description

Bit	Value	Definition
0	0	Do not use touch probe 1.
	1	Use touch probe 1.
1	0	Do not store the position value of the rising edge of touch probe 1.
	1	Store the position value of the rising edge of touch probe 1.
2	0	Do not store the position value for the falling edge of touch probe 1.
	1	Store the position value for the falling edge of touch probe 1.
3 to 5	–	Reserved
6	0, 1	Toggle whether to store all update values for the rising edge of touch probe 1.
7	0, 1	Toggle whether to store all update values for the falling edge of touch probe 1.
8	0	Do not use touch probe 2.
	1	Use touch probe 2.
9	0	Do not store the position value for the falling edge of touch probe 2.
	1	Store the position value for the falling edge of touch probe 2.



Bit	Value	Definition
10	0	Do not store the position value for the falling edge of touch probe 2.
	1	Store the position value for the falling edge of touch probe 2.
11 to 13	–	Reserved
14		Toggle whether to store all update values for the rising edge of touch probe 2.
15	1	Toggle whether to store all update values for the rising edge of touch probe 2.

In continuous trigger mode, you can toggle whether to save all update values for 6, 7, 14 and 15 bits on the rising/falling edge of the touch probe.

To disable bits 1, 2, 9 and 10 (saving the position values on the rising/falling edges of touch probes 1 and 2) of the touch probe state (0x60B9), disable bits 4, 5, 12 and 13 (using sampling on the rising/falling edges of touch probes 1 and 2) of the touch probe function (0x60B8) and enable them.

### 0x60BA, The Touch Probe 1 Positive Edge Position Value

This displays the rising edge position value of touch probe 2.

Index 0x60BA		Touch Probe 1 Positive Edge Position Value					
Sub Index	Initial value	Data Type	Access	PDO Mapping	Setting Range	Change	Unit
0	0	DINT	RO	Yes	–	-	Pos. unit

### 0x60BB, The Touch Probe 1 Negative Edge Position Value

This displays the falling edge position value of touch probe 1.

Index 0x60BB		Touch Probe 1 Negative Edge Position Value					
Sub Index	Initial value	Data Type	Access	PDO Mapping	Setting Range	Change	Unit
0	0	DINT	RO	Yes	–	-	Pos. unit

### 0x60BC, The Touch Probe 2 Positive Edge Position Value

This displays the rising edge position value of touch probe 2.

Index 0x60BC		Touch Probe 2 Positive Edge Position Value					
Sub Index	Initial value	Data Type	Access	PDO Mapping	Setting Range	Change	Unit
0	0	DINT	RO	Yes	–	-	Pos. unit

### 0x60BD, The Touch Probe 2 Negative Edge Position Value

This displays the falling edge position value of touch probe 2.

Index 0x60BD		Touch Probe 2 Negative Edge Position Value					
Sub Index	Initial value	Data Type	Access	PDO Mapping	Setting Range	Change	Unit
0	0	DINT	RO	Yes	-	-	Pos. unit

### 0x60C1, The Interpolation Data Record

This records the interpolation data in Interpolated Position (Ip) mode.

Index 0x60C1		Interpolation Data Record					
Number of entries							
Sub Index	Initial value	Data Type	Access	PDO Mapping	Setting Range	Change	Unit
0	1	USINT	RW	No	-	-	-
Interpolation data record							
Sub Index	Initial value	Data Type	Access	PDO Mapping	Setting Range	Change	Unit
1	0	DINT	RW	Yes	-2147483648 to +2147483647	Always	[Pos. unit]

### 0x60C2, The Interpolation Time Period

This sets the update interval for the interpolated position.

In the DC Sync0 mode, the interpolation time period is automatically set to the Sync0 cycle time.

In the DC Free-run mode, the interpolation time period is set to the application cycle time of the master.

The interpolation time period can be changed in a Switch on Disabled state.

Index 0x60C2	Interpolation time period
--------------	---------------------------

Number of entries							
Sub Index	Initial value	Data Type	Access	PDO Mapping	Setting Range	Change	Unit
0	2	USINT	RO	No	-	-	-
Interpolation time period							
Sub Index	Initial value	Data Type	Access	PDO Mapping	Setting Range	Change	Unit
1	1	USINT	RW	No	1 to 250	Always	-
Interpolation time index							
Sub Index	Initial value	Data Type	Access	PDO Mapping	Setting Range	Change	Unit
2	-3	SINT	RW	No	-6 to -3	Always	-

### 0x60E0, The Positive Torque Limit Value

This sets the torque limit value for forward driving in 0.1% increments of the rated torque.

Index 0x60E0		Positive Torque Limit Value					
Sub Index	Initial value	Data Type	Access	PDO Mapping	Setting Range	Change	Unit
0	3000	UINT	RW	Yes	0 to 65535	Always	[0.1%]

### 0x60E1, The Negative Torque Limit Value

This sets the torque limit value for reverse driving in 0.1% increments of the rated torque.

Index 0x60E1		Negative Torque Limit Value					
Sub Index	Initial value	Data Type	Access	PDO Mapping	Setting Range	Change	Unit
0	3000	UINT	RW	Yes	0 to 65535	Always	[0.1%]

### 0x60F4, The Following Error Actual Value

The following error actual value appears if a following error occurs.

Index 0x60F4		Following Error Actual Value					
Sub Index	Initial value	Data Type	Access	PDO Mapping	Setting Range	Change	Unit
0	0	DINT	RO	Yes	-	-	Pos. unit

### 0x60FC, The Position Demand Internal Value

This displays the values output by the trajectory generator in position mode. These values appear as encoder increments.

Index 0x60FC		Position Demand Internal Value					
Sub Index	Initial value	Data Type	Access	PDO Mapping	Setting Range	Change	Unit
0	0	DINT	RO	Yes	-	-	Pulse

### 0x60FD, The Digital Input

This indicates the digital input state of the L7N's CN1.

Index 0x60FD		Digital Inputs					
Sub Index	Initial value	Data Type	Access	PDO Mapping	Setting Range	Change	Unit
0	0	UDINT	RO	Yes	-	-	-

▪ Details

Bit	Input	Details
0	N-OT: The reverse limit switch	0: Off, 1: On
1	P-OT: The forward limit switch	0: Off 1: On
2	Home switch	0: Off, 1: On
3 to 15	-	Reserved
16	DI#1:CN1-13pin	0: Switched off (Open), 1: Switched on (Close)
17	DI#2:CN1-14pin	0: Switched off (Open), 1: Switched on (Close)
18	DI#3:CN1-12pin	0: Switched off (Open), 1: Switched on (Close)
19	DI#4:CN1-11pin	0: Switched off (Open), 1: Switched on (Close)
20	DI#5:CN1-08pin	0: Switched off (Open), 1: Switched on (Close)
21	DI#6:CN1-07pin	0: Switched off (Open), 1: Switched on (Close)
22	HWBB	Hardwired base block signal input (0: Open, 1: Close)
23 to 31	-	Reserved

### 0x60FE, The Digital Output

This indicates the digital output state of the L7N's CN1.

Sub-Index 1 controls the actual output state.

Sub-Index 2 defines the logic of the Sub-Index 1 activated.

Index 0x60FE	Digital Outputs
Number of entries	

Sub Index	Initial value	Data Type	Access	PDO Mapping	Setting Range	Change	Unit
0	2	UDINT	RW	No		-	-
Physical outputs							
Sub Index	Initial value	Data Type	Access	PDO Mapping	Setting Range	Change	Unit
1	0	UDINT	RW	Yes	0 to 0xFFFFFFFF F	Always	-
Bit mask							
Sub Index	Initial value	Data Type	Access	PDO Mapping	Setting Range	Change	Unit
2	0	UDINT	RW	No	0 to 0xFFFFFFFF F	Always	-

▪ Description of physical outputs

Bit	Output	Details
0 to 15	–	Reserved
16	DO#1:CN1 03-04 pin	Forced output (0: off, 1: on). Provided that 0x60FE:02.16 is set to 1.
17	DO#2:CN1 23-24 pin	Forced output (0: off, 1: on). Provided that 0x60FE:02.17 is set to 1.
18	DO#3:CN1 25-26 pin	Forced output (0: off, 1: on). Provided that 0x60FE:02.18 is set to 1.
19	DO#4:CN1 01-02 pin	Forced output (0: off, 1: on). Provided that 0x60FE:02.19 is set to 1.
20 to 23	–	Reserved
24	DO#1:CN1 03-04 pin	Hardware output state (0: off, 1: on).
25	DO#2:CN1 23-24 pin	Hardware output state (0: off, 1: on).
26	DO#3:CN1 25-26 pin	Hardware output state (0: off, 1: on).
27	DO#4:CN1 01-02 pin	Hardware output state (0: off, 1: on).
28 to 31	–	Reserved

▪ Description of the output mask

Bit	Output	Details
0 to 15	–	Reserved
16	DO#1:CN1 03-04 pin	DO#1 Forced output enabled
17	DO#2:CN1 23-24 pin	DO#2 Forced output enabled
18	DO#3:CN1 25-26 pin	DO#3 Forced output enabled
19	DO#4:CN1 01-02 pin	DO#4 Forced output enabled
20 to 31	–	Reserved

## 0x60FF, The Target Velocity

This sets the target velocity in user-defined units [Vel. unit] in Profile Velocity (Pv) mode and Cyclic Synchronous Velocity (Csv) mode.

Index 0x60FF		Target Velocity					
Sub Index	Initial value	Data Type	Access	PDO Mapping	Setting Range	Change	Unit
0	0	DINT	RW	Yes	-2147483648 to +2147483647	Always	Vel. unit

## 0x6502, Supported Drive Modes

This displays the drive modes that the L7N supports.

Index 0x6502		Supported Drive Modes					
Sub Index	Initial value	Data Type	Access	PDO Mapping	Setting Range	Change	Unit
0	1005	UDINT	RO	No	-	-	-

- Details

Bit	Supported modes	Details
0	Pp (Profile Position mode)	1: Supported
1	VI (Velocity mode)	0: Not supported
2	Pv (Profile Velocity mode)	1: Supported
3	Tq (Profile Torque mode)	1: Supported
4	Reserved	0
5	Hm (Homing mode)	1: Supported
6	Ip (Interpolated Position mode)	1: Supported
7	Csp (Cyclic Sync Position mode)	1: Supported
8	Csv (Cyclic Sync Velocity mode)	1: Supported
9	Cst (Cyclic Sync Torque mode)	1: Supported
10 to 31	Reserved	0

# 9. Handling and Operation

## 9.1 Operation Checklist

Thoroughly check the following items during the test drive to prevent injuries or damage to the servo motor.

### 9.1.1 Wiring Checklist

1. Is the voltage (AC 200 V) appropriate for the power input terminals?
2. Are the power cables (U, V, W, and FG) between the drive and the motor connected correctly?
3. Is the voltage (24 V) connected to the control signal correctly?
4. Is the regenerative resistance appropriate for the capacity and correctly connected?
5. Are the wiring cables free from bends or kinks?
6. Is the ground and wire insulation free from defects?

### 9.1.2 Drive Signal (CN1) Wiring Checklist

Confirm that the wire and contacts for the drive signals are in the state listed on the following table.

Pin Number	Pin Name	State of Contact	Pin Number	Pin Name	State of Contact
16	PCON	Off	14	HOME	On
17	GAIN2	Off	8	P-OT	On
15	ALMRST	Off	7	N-OT	On

The previous table lists the factory default settings. You can allocate different values according to the setting value of the input signal allocations ([0x2200] and [0x2201]) and input signal logic definition ([0x2204]).

### 9.1.3 Surrounding Environment Checklist

Are there any metal filings or water around the wires?

### 9.1.4 Machine Status Checklist

1. Is the servo motor coupling in good condition?
2. Are the locking bolts fastened tightly?
3. Are there any obstacles that may prohibit operation of the machine?





# 10. Product Specifications

## 10.1 The Servo Motor

### ■ Heat Sink specification

Classification	Standard (mm)	Classification
AP04	250x250x6	Aluminum
AP06	250x250x6	
AP08	250x250x12	
AP13	350x350x20	
AP18	550x550x30	
AP22	650x650x35	

Note 1) The data on the product features is measured when those heat sinks were applied.

## 10.1.1 Product Features

### 10.1.2

Servo Motor Type (APM-□□□□□)		SAR3A	SAR5A	SA01A	SA015A
Applicable Drive (L7□A□□)		L7□A001			L7□A002
Rated output	[kW]	0.03	0.05	0.10	0.15
Rated torque	[N·m]	0.10	0.16	0.32	0.48
	[kgf·cm]	0.97	1.62	3.25	4.87
Maximum instantaneous torque	[N·m]	0.29	0.48	0.96	1.43
	[kgf·cm]	2.92	4.87	9.74	14.62
Rated current	[A]	1.07	1.20	1.38	1.73
Maximum current	[A]	3.21	3.60	4.14	5.19
Rated rotation speed	[r/min]	3000			
Maximum rotation speed	[r/min]	5000			
Inertia moment	[kg·m <sup>2</sup> ×10 <sup>-4</sup> ]	0.0164	0.02	0.05	0.06
	[gf·cm·s <sup>2</sup> ]	0.0167	0.02	0.05	0.07
Allowed load inertia		Motor inertia x 30			Motor inertia x 20
Rated power rate	[kW/s]	5.56	10.55	23.78	35.34
Speed and position detector	Standard	Quad. Type Incremental 2048[P/R]			
	Option	Serial Type(coming soon)			
Specifications and features	Protection method	Fully closed-self-cooling IP55(excluding axis penetration)			
	Time rating	Continuous			
	Ambient temperature	0~40[°C]			
	Ambient humidity	20~80[%]RH (no condensation)			
	Atmosphere	No direct sunlight, corrosive gas, or combustible gas			
	Anti-vibration	Vibration acceleration of 49[m/s <sup>2</sup> ](5G)			
Weight	[kg]	0.3	0.4	0.5	0.7

◆ Rotation Speed - Torque Characteristics ◆

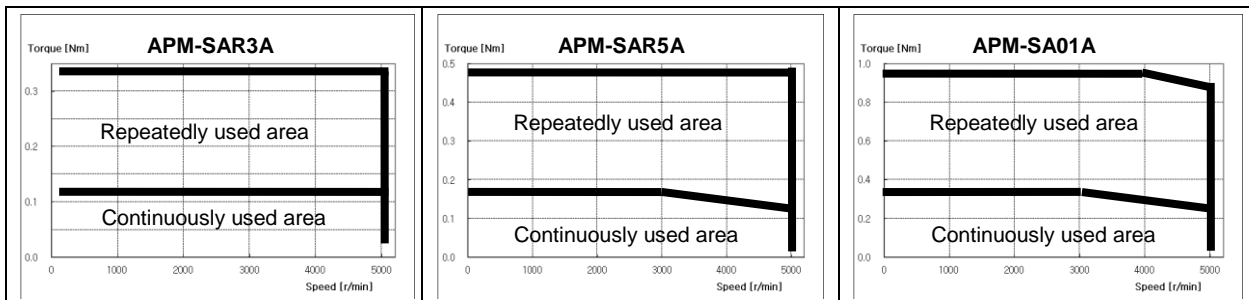



## ■ Product Features

Servo Drive Type (APM-□□□□□)		SB01A	SB02A	SB04A		
Applicable Drive (L7□A□□)		L7□A002		L7□A004		
Rated output	[kW]	0.10	0.20	0.40		
Rated torque	[N·m]	0.32	0.64	1.27		
	[kgf·cm]	3.25	6.49	12.99		
Maximum instantaneous torque	[N·m]	0.96	1.91	3.82		
	[kgf·cm]	9.74	19.48	38.96		
Rated current	[A]	1.65	1.63	2.89		
Maximum current	[A]	4.95	4.89	8.67		
Rated rotation speed	[r/min]	3000				
Maximum rotation speed	[r/min]	5000				
Inertia moment	[kg·m <sup>2</sup> ×10 <sup>-4</sup> ]	0.11	0.18	0.32		
	[gf·cm·s <sup>2</sup> ]	0.12	0.19	0.33		
Allowed load inertia		Motor inertia x 20				
Rated power rate	[kW/s]	8.89	22.26	50.49		
Speed and position detector	Standard	Quad. Type Incremental 3000[P/R]				
	Option	Serial Type 19[Bit]				
Specifications and features	Protection method	Fully closed-self-cooling IP65(excluding axis penetration)				
	Time rating	Continuous				
	Ambient temperature	0~40[°C]				
	Ambient humidity	20~80[%]RH (no condensation)				
	Atmosphere	No direct sunlight, corrosive gas, or combustible gas				
	Anti-vibration	Vibration acceleration 49[m/s <sup>2</sup> ](5G)				
Weight	[kg]	0.8	1.1	1.6		

◆ Rotation speed – Torque Characteristics ◆

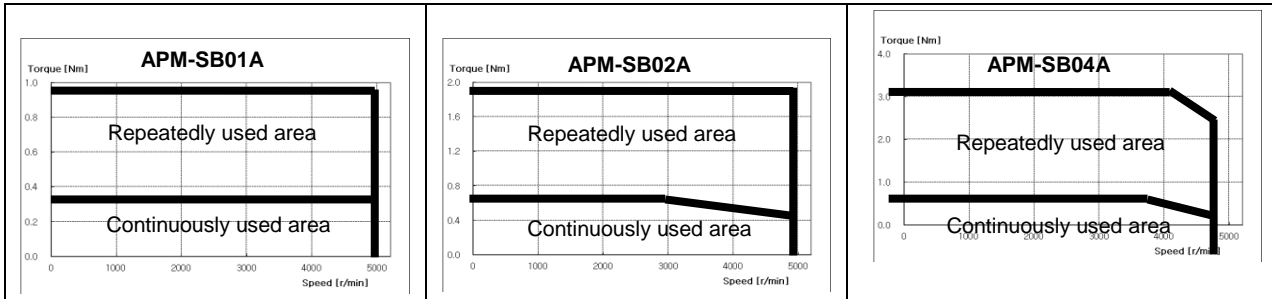

## ■ Product Features

Servo Motor Type (APM-□□□□□)		SC04A	SC06A	SC08A	SC10A		
Applicable drive (L7□A□□)		L7□A004	L7□A008		L7□A010		
Rated output	[kW]	0.4	0.6	0.8	1.0		
	[N·m]	1.27	1.91	2.55	3.19		
Rated torque	[kgf·cm]	12.99	19.49	25.98	32.48		
	[N·m]	3.82	5.73	7.64	9.56		
Maximum instantaneous torque	[kgf·cm]	38.96	58.47	77.95	97.43		
	[A]	2.82	3.58	4.83	5.37		
Rated current	[A]	8.46	10.74	14.49	16.11		
Maximum current	[A]						
Rated rotation speed	[r/min]	3000					
Maximum rotation speed	[r/min]	5000					
Inertia moment	[kg·m <sup>2</sup> ×10 <sup>-4</sup> ]	0.67	1.09	1.51	1.93		
	[gf·cm·s <sup>2</sup> ]	0.69	1.11	1.54	1.97		
Allowed load inertia		Motor inertia x 15					
Rated power rate	[kW/s]	24.05	33.39	43.02	52.57		
Speed and position detector	Standard	Quadrature Type Incremental 3000[P/R]					
	Option	Serial Type 19[bit]					
Specifications and features	Protection method	Fully closed-self-cooling IP65(excluding axis penetration)					
	Time rating	Continuous					
	Ambient temperature	0~40[°C]					
	Ambient humidity	20~80[%]RH (no condensation)					
	Atmosphere	No direct sunlight, corrosive gas, or combustible gas					
	Anti-vibration	Vibration acceleration 49[m/s <sup>2</sup> ](5G)					
Weight	[kg]	1.9	2.5	3.2	3.8		

◆Rotation Speed - Torque Characteristics◆

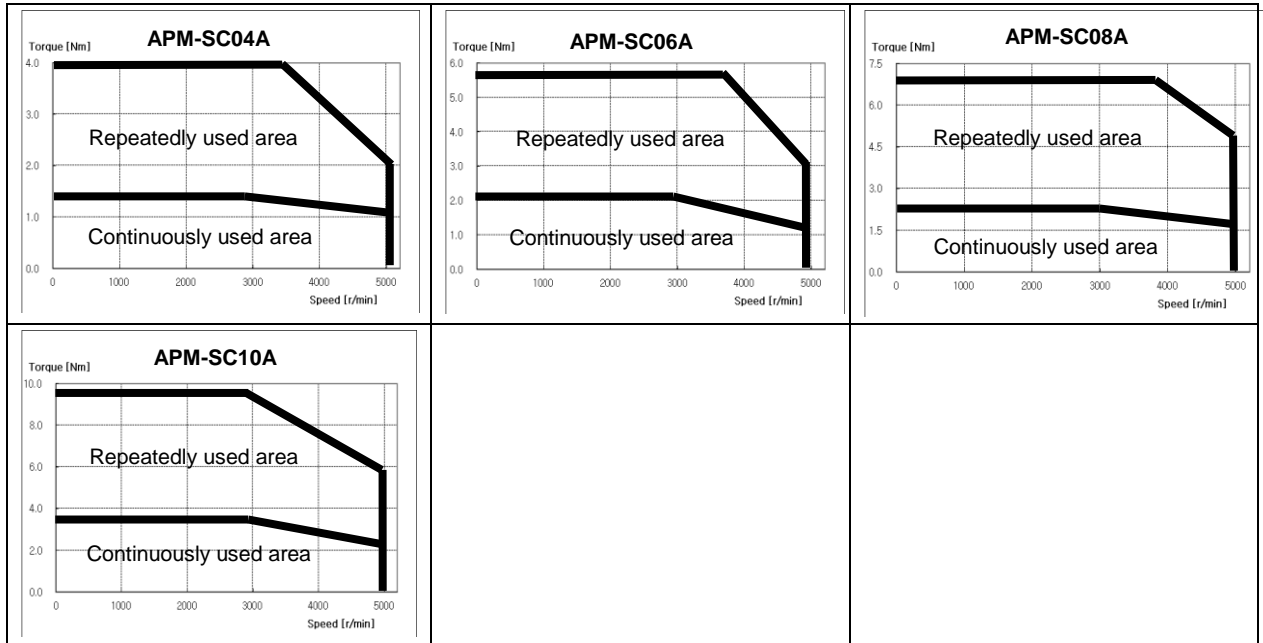

## ■ Product Features

Servo Motor Type (APM-□)		SC03D	SC05D	SC06D	SC07D			
Applicable Drive (L7□A□□)		L7□A004	L7□A008					
Rated Output	[kW]	0.30	0.45	0.55	0.65			
Rated torque	[N·m]	1.43	2.15	2.63	3.10			
	[kgf·cm]	14.61	21.92	26.79	31.66			
Instantaneous maximum torque	[N·m]	4.30	6.45	7.88	9.31			
	[kgf·cm]	43.84	65.77	80.38	94.99			
Rated rotation speed	[r/min]	2000						
Maximum rotation speed	[r/min]	3000						
Inertia moment	[kg·m <sup>2</sup> ×10 <sup>-4</sup> ]	0.67	1.09	1.51	1.93			
	[gf·cm·s <sup>2</sup> ]	0.69	1.11	1.54	1.97			
Allowable load inertia		Motor inertia x 15						
Rated power rate	[kW/s]	30.43	42.27	45.69	47.97			
Speed and position detector	Standard	Quadrature Type Incremental 2500[P/R]						
	Option	Serial Type 19[bit]						
Specifications and features	Method of protection	Fully closed-self-cooling IP65 (excluding axis penetration)						
	Time rating	Continuous						
	Ambient temperature	0-40 [°C]						
	Ambient humidity	20-80[%] RH (no condensation)						
	Atmosphere	No direct sunlight, corrosive gas, or combustible gas						
	Anti-vibration	Vibration acceleration 49 [m/s <sup>2</sup> ] (5G)						
Weight	[kg]	1.9	2.5	3.2	3.9			

◆ Rotation Speed - Torque Characteristics ◆

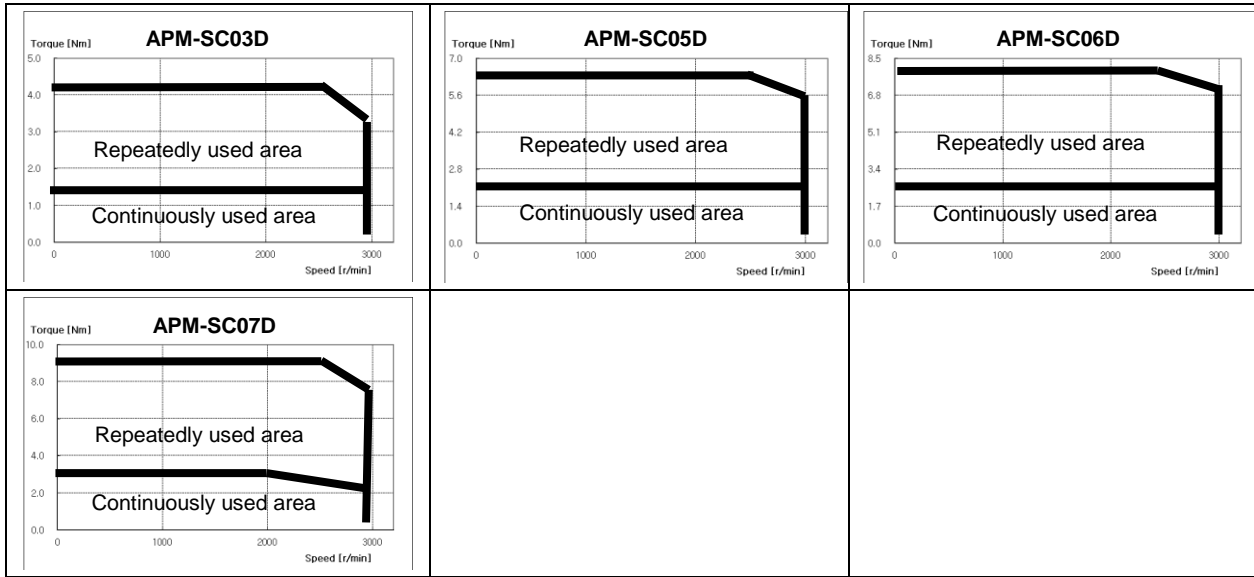

■ Product Features

Servo Motor Type (APM-□□□□□)		SE09A	SE15A	SE22A	SE30A	SE06D	SE11D
Applicable drive (L7□A□□)		L7□A008	L7□A020		L7□A035	L7□A008	L7□A010
Rated output	[kW]	0.9	1.5	2.2	3.0	0.6	1.1
Rated torque	[N·m]	2.86	4.77	7.00	9.55	2.86	5.25
	[kgf·cm]	29.23	48.72	71.45	97.43	29.23	53.59
Maximum instantaneous torque	[N·m]	8.59	14.32	21.01	28.64	8.59	15.75
	[kgf·cm]	87.69	146.15	214.35	292.29	87.69	160.76
Rated current	[A]	4.95	8.23	11.98	17.16	3.97	6.28
Maximum current	[A]	14.85	24.69	35.94	51.48	11.91	18.84
Rated rotation speed	[r/min]	3000				2000	
Maximum rotation speed	[r/min]	5000				3000	
Inertia moment	[kg·m <sup>2</sup> ×10 <sup>-4</sup> ]	6.66	12.00	17.34	22.68	6.66	12.00
	[gf·cm·s <sup>2</sup> ]	6.80	12.24	17.69	23.14	6.80	12.24
Allowed load inertia		Motor inertia x 10					
Rated power rate	[kW/s]	12.32	18.99	28.28	40.20	12.32	22.98
Speed and position detector	Standard	Quadrature Type Incremental 3000[P/R]					
	Option	Serial Type 19[bit]					
Specifications and features	Protection method	Fully closed:self-cooling IP65(excluding axis penetration)					
	Time rating	Continuous					
	Ambient temperature	0~40[°C]					
	Ambient humidity	20~80[%]RH(no condensation)					
	Atmosphere	No direct sunlight, corrosive gas, or combustible gas					
Anti-vibration	Vibration acceleration 49[m/s <sup>2</sup> ](5G)						

Weight	[kg]	5.5	7.5	9.7	11.8	5.5	7.5
--------	------	-----	-----	-----	------	-----	-----

◆ Rotation speed – Torque Characteristics ◆

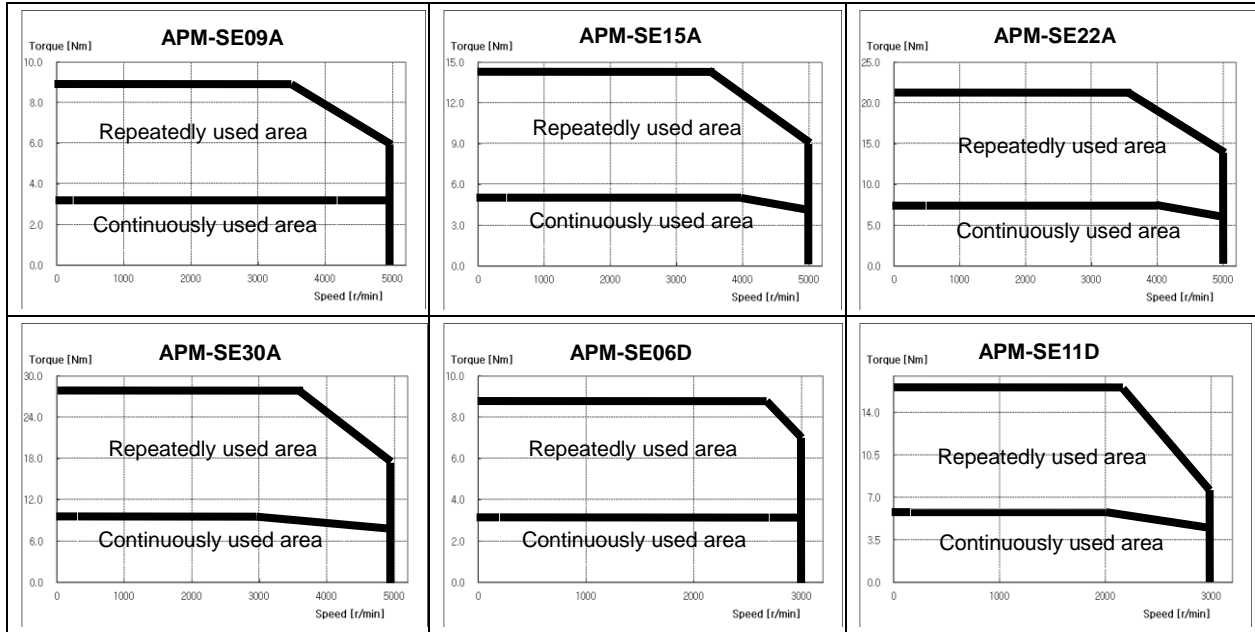

## ■ Product Features

Servo Motor Type (APM-□□□□□)		SE16D	SE22D	SE03M	SE06M	SE09M	SE12M
Applicable drive (L7□A□□)		L7□A020		L7□A004	L7□A008	L7□A010	L7□A020
Rated output	[kW]	1.6	2.2	0.3	0.6	0.9	1.2
	[N·m]	7.64	10.50	2.86	5.73	8.59	11.46
Rated torque	[kgf·cm]	77.94	107.17	29.23	58.46	87.69	116.92
	[N·m]	22.92	31.51	8.59	17.19	25.78	34.37
Maximum instantaneous torque	[kgf·cm]	233.83	321.52	87.69	175.30	263.06	350.75
	[A]	9.23	12.37	2.51	4.15	5.78	7.63
Maximum current	[A]	27.69	37.11	7.53	12.45	17.34	22.89
Rated rotation speed	[r/min]	2000		1000			
Maximum rotation speed	[r/min]	3000		2000			
Inertia moment	[kg·m <sup>2</sup> ×10 <sup>-4</sup> ]	17.34	22.68	6.66	12.00	17.34	22.68
	[gf·cm·s <sup>2</sup> ]	17.69	23.14	6.80	12.24	17.69	23.14
Allowed load inertia		Motor inertia x 10					
Rated power rate	[kW/s]	33.65	48.64	12.32	27.35	42.59	57.89
Speed and position detector	Standard	Quadrature Type Incremental 3000[P/R]					
	Option	Serial Type 19[bit]					
Specifications and features	Protection Method	Fully closed-self-cooling IP65(excluding axis penetration)					
	Time rating	Continuous					
	Ambient temperature	0~40[°C]					
	Ambient humidity	20~80[%]RH(no condensation)					

	Atmosphere	No direct sunlight, corrosive gas, or combustible gas					
	Anti-vibration	Vibration acceleration 49[m/s <sup>2</sup> ](5G)					
Weight	[kg]	9.7	11.8	5.5	7.5	9.7	11.8

◆ Rotation speed – Torque Characteristics ◆

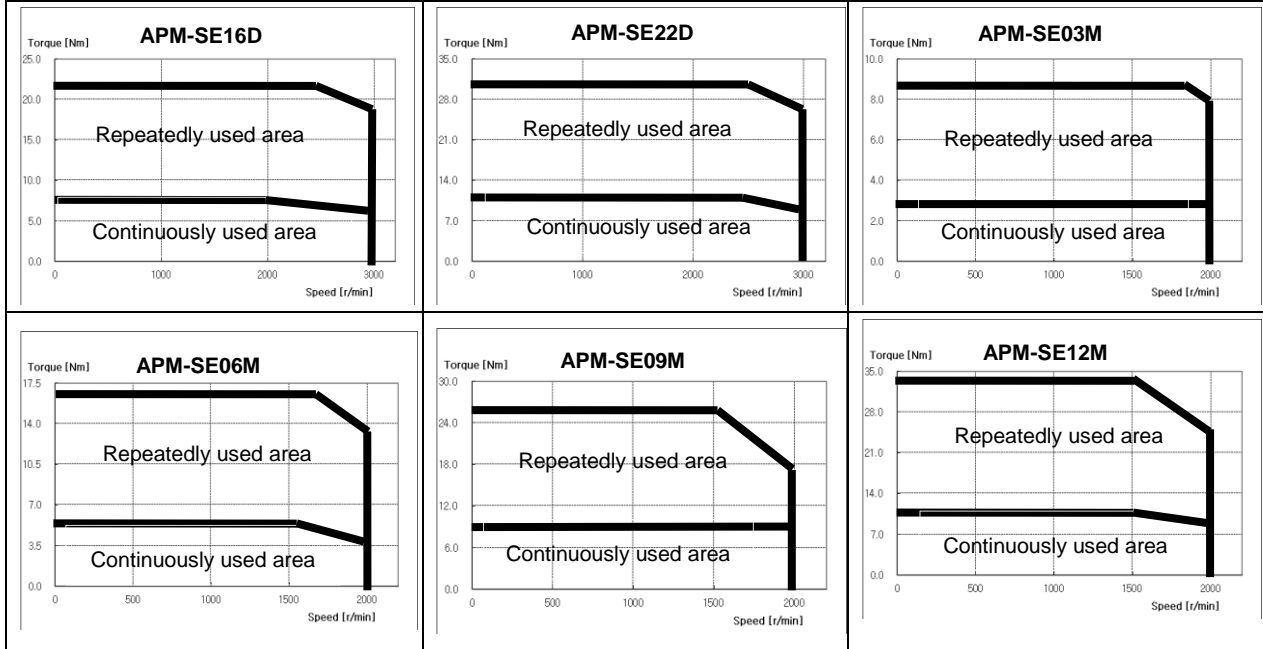

## Product Features

Servo Motor Type (APM-□□□□□)		SE05G	SE09G	SE13G	SE17G	SF30A	SF50A
Applicable drive (L7□A□□)		L7□A008	L7□A010	L7□A020		L7□A035	L7□A050
Rated output	[kW]	0.45	0.85	1.3	1.7	3.0	5.0
Rated torque	[N·m]	2.86	5.41	8.28	10.82	9.55	15.91
	[kgf·cm]	29.23	55.21	84.44	110.42	97.43	162.38
Maximum instantaneous torque	[N·m]	8.59	16.23	24.83	32.46	28.64	47.74
	[kgf·cm]	87.69	165.63	253.32	331.26	292.29	487.15
Rated current	[A]	3.97	6.47	10.00	12.75	16.70	27.40
Maximum current	[A]	11.91	19.41	30.00	38.25	50.1	82.20
Rated rotation speed	[r/min]	1500				3000	
Maximum rotation speed	[r/min]	3000				5000	
Inertia moment	[kg·m <sup>2</sup> ×10 <sup>-4</sup> ]	6.66	12.00	17.34	22.68	30.74	52.13
	[gf·cm·s <sup>2</sup> ]	6.80	12.24	17.69	23.14	31.37	53.19
Allowed load inertia		Motor inertia x 10				Motor inertia x 5	
Rated power rate	[kW/s]	12.32	24.40	39.49	51.63	29.66	48.58
Speed and position detector	Standard	Quadrature Type Incremental 3000[P/R]					
	Option	Serial Type 19[bit]					
Specifications and features	Protection method	Fully closed-self-cooling IP65(excluding axis penetration)					
	Time rating	Continuous					



	Ambient temperature	0~40[°C]					
	Ambient humidity	20~80[%]RH(no condensation)					
	Atmosphere	No direct sunlight, corrosive gas, or combustible gas					
	Anti-vibration	Vibration acceleration 49[m/s <sup>2</sup> ](5G)					
Weight	[kg]	5.5	7.5	9.7	11.8	12.4	17.7

◆ Rotation speed – Torque Characteristics ◆

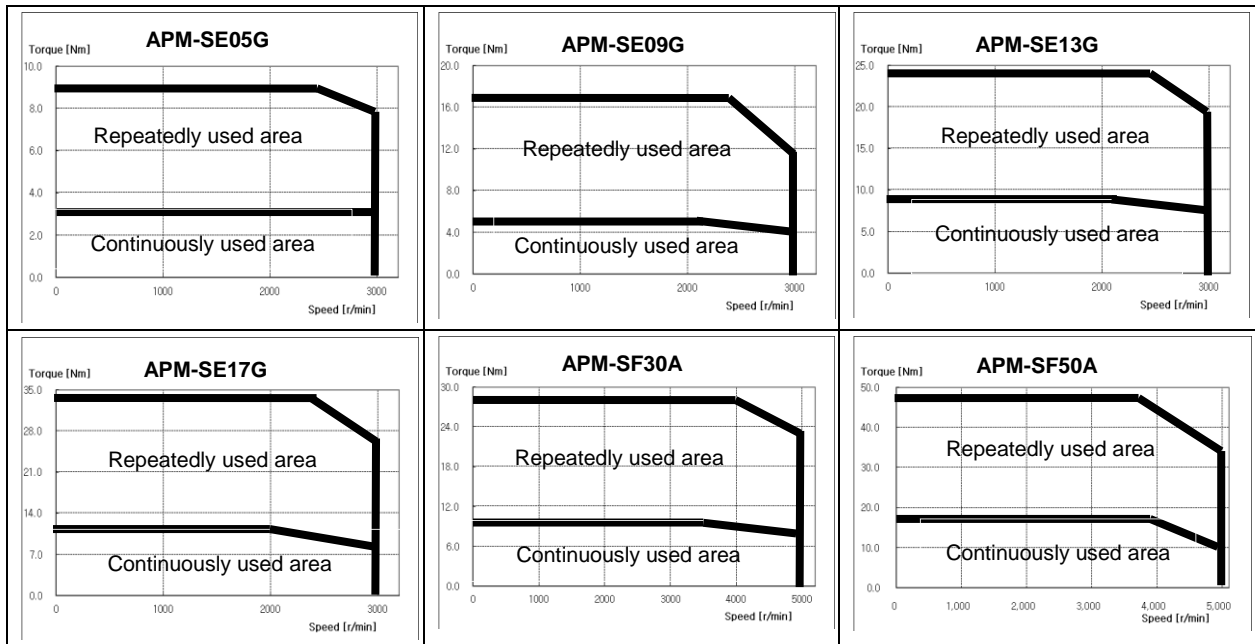

■ Product Features

Servo Motor Type (APM-□□□□□)		SF22D	LF35D	SF55D	SF20G	LF30G	SF44G
Applicable drive (L7□A□□)		L7□A020	L7□A035	L7□A050	L7□A035		L7□A050
Rated output	[kW]	2.2	3.5	5.5	1.8	2.9	4.4
Rated torque	[N·m]	10.50	16.71	26.26	11.46	18.46	28.01
	[kgf·cm]	107.17	170.50	267.93	116.92	188.37	285.80
Maximum instantaneous torque	[N·m]	31.51	50.13	78.77	34.37	55.38	84.02
	[kgf·cm]	321.52	511.51	803.80	350.75	565.10	857.39
Rated current	[A]	13.50	15.85	30.25	14.7	15.92	31.75
Maximum current	[A]	40.50	47.55	90.75	44.1	47.64	95.25
Rated rotation speed	[r/min]	2000			1500		
Maximum rotation speed	[r/min]	3000			3000	2700	3000
Inertia moment	[kg·m <sup>2</sup> ×10 <sup>-4</sup> ]	30.74	52.13	85.31	30.74	52.13	83.60
	[gf·cm·s <sup>2</sup> ]	31.35	53.16	83.60	31.37	53.19	85.31
Allowed load inertia		Motor inertia x 5					
Rated power rate	[kW/s]	35.88	53.56	82.47	42.71	65.37	93.83
Speed and position detector	Standard	Quadrature Type Incremental 3000[P/R]					
	Option	Serial Type 19[bit]					

Specifications and features	Protection method	Fully closed self-cooling IP65(excluding axis penetration)					
	Time rating	Continuous					
	Ambient temperature	0~40[°C]					
	Ambient humidity	20~80[%]RH(no condensation)					
	Atmosphere	No direct sunlight, corrosive gas, or combustible gas					
	Anti-vibration	Vibration acceleration 49[m/s <sup>2</sup> ](5G)					
Weight	[kg]	12.4	17.7	26.3	12.4	17.7	26.3

◆ Rotation speed – Torque Characteristics ◆

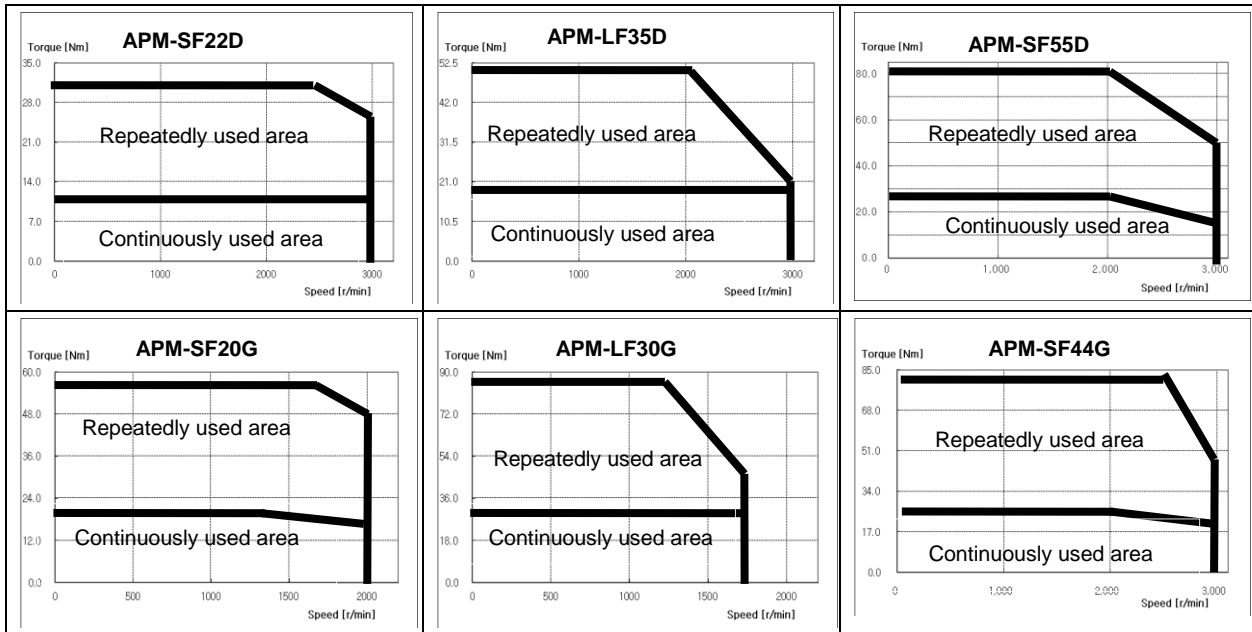

## ■ Product Features

Servo Motor Type (APM-□□□□□)	SF12M	SF20M	LF30M	SF44M			
Applicable drive (L7□A□□)	L7□A020	L7□A035		L7□A050			
Rated output	[kW]	1.2	2.0	3.0	4.4		
Rated torque	[N·m]	11.46	19.10	28.64	42.01		
	[kgf·cm]	116.92	194.86	292.29	428.69		
Maximum instantaneous torque	[N·m]	34.37	57.29	85.93	126.04		
	[kgf·cm]	350.75	584.58	876.88	1286.08		
Rated current	[A]	8.40	14.40	15.99	31.24		
Maximum current	[A]	25.2	43.2	47.97	93.72		
Rated rotation speed	[r/min]	1000					

Maximum rotation speed	[r/min]	2000		1700	2000		
Inertia moment	[kg·m <sup>2</sup> ×10 <sup>-4</sup> ]	30.74	52.13	83.60	121.35		
	[gf·cm·s <sup>2</sup> ]	31.37	53.19	85.31	123.83		
Allowed load inertia		Motor inertia x 5					
Rated power rate	[kW/s]	42.71	69.95	98.15	145.45		
Speed and position detector	Standard	Quadrature Type Incremental 3000[P/R]					
	Option	Serial Type 19[bit]					
Specifications and features	Protection method	Fully closed-self-cooling IP65(excluding axis penetration)					
	Time rating	Continuous					
	Ambient temperature	0~40[°C]					
	Ambient humidity	20~80[%]RH(no condensation)					
	Atmosphere	No direct sunlight, corrosive gas, or combustible gas					
	Anti-vibration	Vibration acceleration 49[m/s <sup>2</sup> ](5G)					
Weight	[kg]	12.4	17.7	26.3	35.6		

◆ Rotation Speed - Torque Characteristics ◆

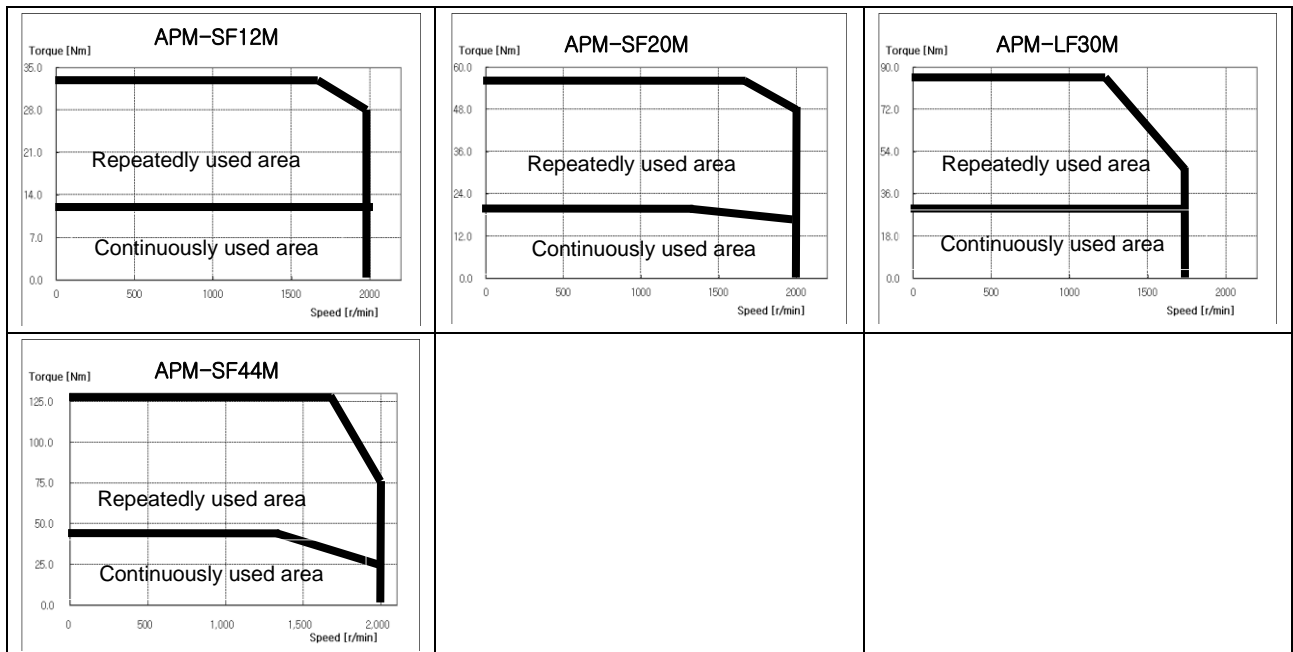

■ Product Features

Servo Motor Type (APM-□□□□□)	SG20G	LG30G	SG44G	SG22D	LG35D	SG55D
Applicable drive (L7□A□□)	L7□A020	L7□A035	L7□A050	L7□A020	L7□A035	L7□A050
Rated output	1.8	2.9	4.4	2.2	3.5	5.5
Rated torque	11.46	18.46	28.01	10.50	16.71	26.26
	116.92	188.37	285.80	107.20	170.52	267.9
Maximum instantaneous torque	34.47	55.38	84.02	31.51	50.13	78.77
	350.80	565.10	857.39	321.52	511.51	803.8

Rated current	[A]	13.10	16.19	31.50	12.30	16.05	30.25
Maximum current	[A]	39.3	48.57	94.5	36.9	48.15	90.75
Rated rotation speed	[r/min]	1500			2000		
Maximum rotation speed	[r/min]	3000	2700	3000	3000		
Inertia moment	[kg·m <sup>2</sup> ×10 <sup>-4</sup> ]	51.42	80.35	132.41	51.42	80.35	135.11
	[gf·cm·s <sup>2</sup> ]	52.47	81.99	135.11	52.47	81.99	132.41
Allowed load inertia		Motor inertia x 5					
Rated power rate	[kW/s]	25.53	42.41	59.24	21.45	34.75	52.07
Speed and position detector	Standard	Quadrature Type Incremental 3000[P/R]					
	Option	Serial Type 19[bit]					
Specifications and features	Protection method	Fully closed-self-cooling IP65(excluding axis penetration)					
	Time rating	Continuous					
	Ambient temperature	0~40[°C]					
	Ambient humidity	20~80[%]RH(no condensation)					
	Atmosphere	No direct sunlight, corrosive gas, or combustible gas					
	Anti-vibration	Vibration acceleration 49[m/s <sup>2</sup> ](5G)					
Weight	[kg]	17.0	22.0	30.8	17.0	22.0	30.8

◆ Rotation Speed - Torque Characteristics ◆

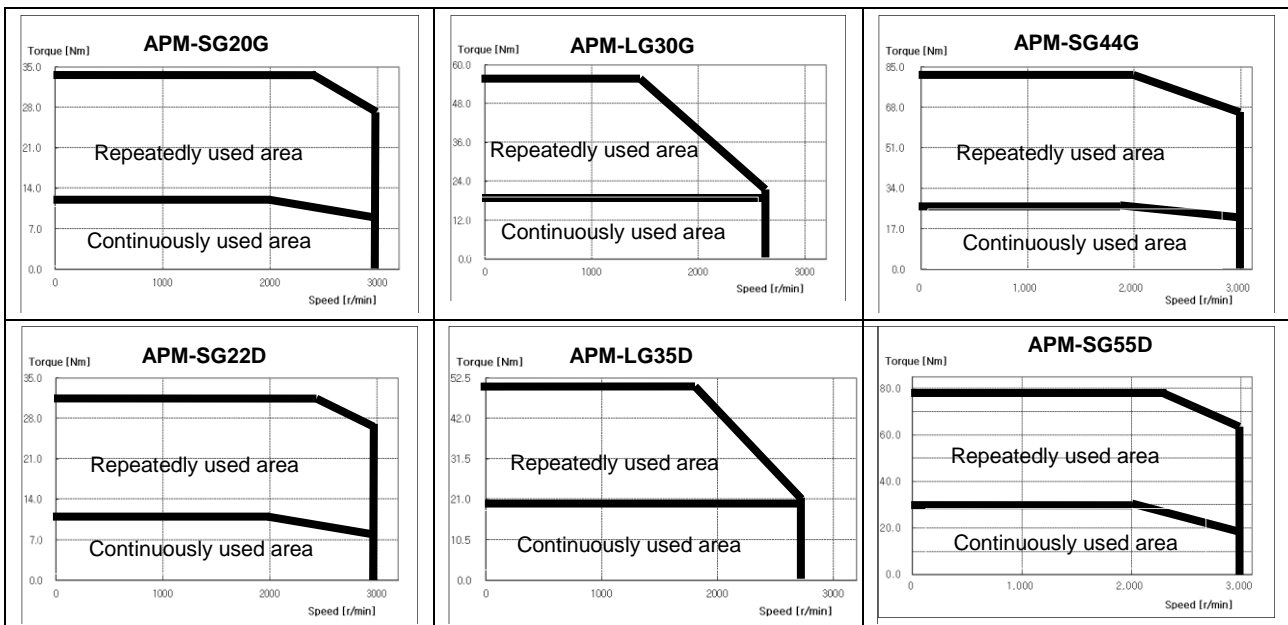

■ Product Features

Servo Motor Type (APM-□□□□□)	SG12M	SG20M	LG30M	SG44M		
Applicable Drive (L7□A□□)	L7□A020	L7□A035		L7□A050		
Rated output	[kW]	1.2	2.0	3.0	4.4	
Rated torque	[N·m]	11.46	19.10	28.64	42.01	

	[kgf·cm]	116.92	194.86	292.29	428.69		
Maximum instantaneous torque	[N·m]	34.37	57.29	85.93	126.04		
	[kgf·cm]	350.75	584.58	876.88	1286.08		
Rated current	[A]	8.87	15.02	16.04	31.83		
Maximum current	[A]	26.61	45.06	48.12	95.49		
Rated rotation speed	[r/min]	1000					
Maximum rotation speed	[r/min]	2000		1700	2000		
Inertia moment	[kg·m <sup>2</sup> ×10 <sup>-4</sup> ]	51.42	80.35	132.41	172.91		
	[gf·cm·s <sup>2</sup> ]	52.47	81.99	135.11	176.44		
Allowed load inertia		Motor inertia x 5					
Rated power rate	[kW/s]	25.53	45.39	61.97	102.08		
Speed and position detector	Standard	Quadrature Type Incremental 3000[P/R]					
	Option	Serial Type 19[bit]					
Specifications and features	Protection method	Fully closed-self-cooling IP65(excluding axis penetration)					
	Time rating	Continuous					
	Ambient temperature	0~40[°C]					
	Ambient humidity	20~80[%]RH(no condensation)					
	Atmosphere	No direct sunlight, corrosive gas, or combustible gas					
	Anti-vibration	Vibration acceleration 49[m/s <sup>2</sup> ](5G)					
Weight	[kg]	17.0	22.0	30.8	37.5	17.0	22.0

◆ Rotation Speed - Torque Characteristics ◆

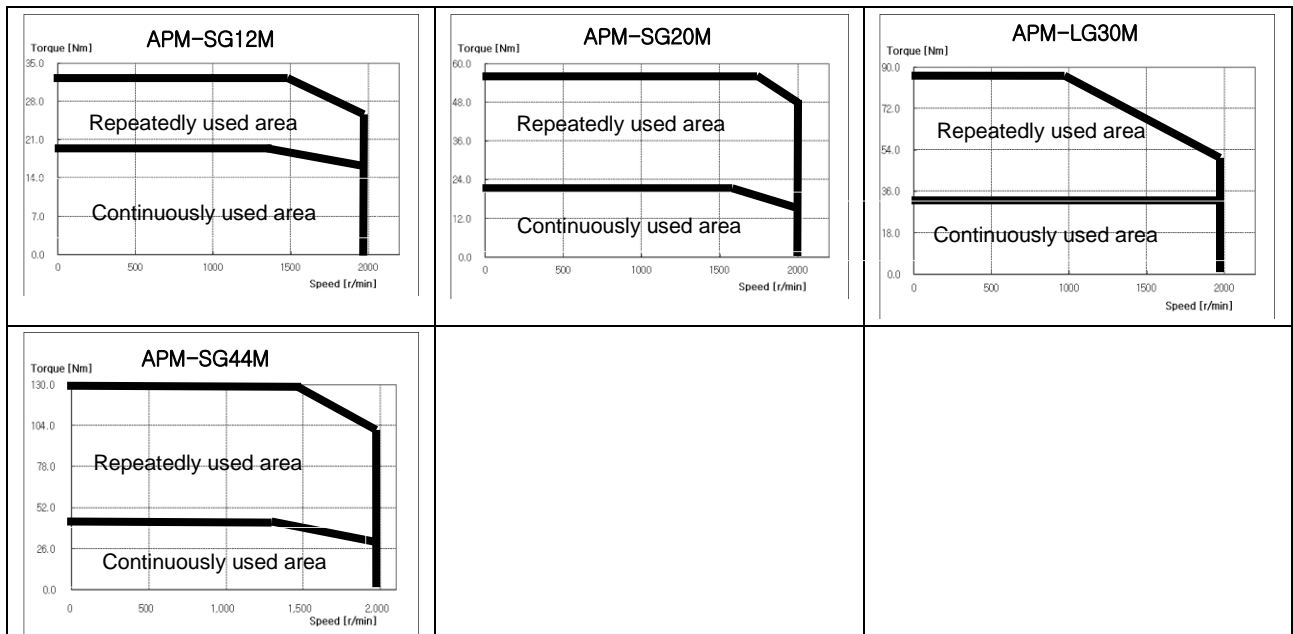

■ Product Features

Servo Motor Type (APM-□)		HB01A	HB02A	HB04A	HE09A	HE15A		
Applicable Drive (L7□A□□)		L7□A002A		L7□A004A	L7□A008A	L7□A020A		
Rated Output	[kW]	0.1	0.2	0.4	0.9	1.5		
Rated torque	[N·m]	0.32	0.64	1.27	2.86	4.77		
	[kgf·cm]	3.25	6.49	12.99	29.23	48.72		
Instantaneous maximum torque	[N·m]	0.96	1.91	3.82	8.59	14.32		
	[kgf·cm]	9.74	19.48	38.96	87.69	146.15		
Rated current	[A]	1.65	1.63	2.89	4.95	8.23		
Maximum current	[A]	4.95	4.89	8.67	14.85	24.69		
Rated rotation speed	[r/min]	3000						
Maximum rotation speed	[r/min]	3500						
Inertia moment	[kg·m <sup>2</sup> ×10 <sup>-4</sup> ]	0.27	0.333	0.46	19.56	22.27		
	[gf·cm·s <sup>2</sup> ]	0.274	0.34	0.47	19.96	22.72		
Allowable load inertia		Motor inertia x 20			Motor inertia x 10			
Rated power rate	[kW/s]	3.34	11.98	34.47	4.10	10.01		
Speed and position detector	Standard	Quadrature Type Incremental 1024P/R			2048 P/R			
	Option	x						
Specifications and features	Method of protection	Fully closed-self-cooling IP65 (excluding axis penetration)						
	Time rating	Continuous						
	Ambient temperature	0-40 [°C]						
	Ambient humidity	20-80[%] RH (no condensation)						
	Atmosphere	No direct sunlight, corrosive gas, or combustible gas						
	Anti-vibration	Vibration acceleration 49 [m/s <sup>2</sup> ] (5G)						
Weight	[kg]	0.9	1.2	1.7	5.8	7.4		

◆ Rotation Speed - Torque Characteristics ◆

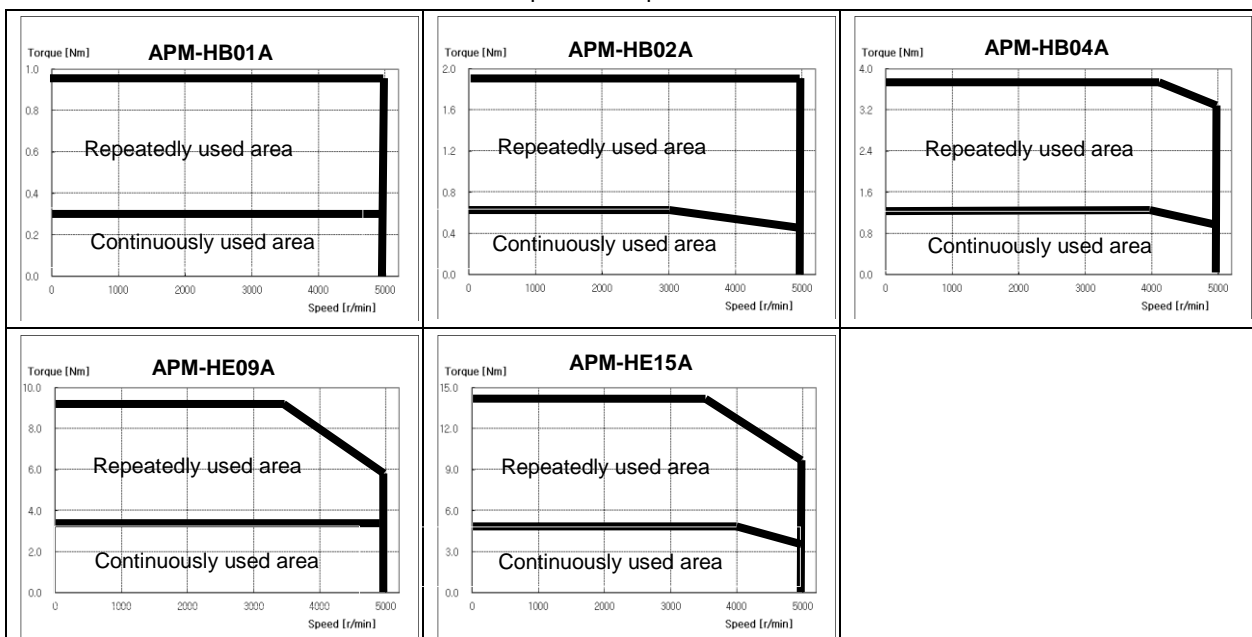

## Product Features

Servo Motor Type (APM-□)		FB01A	FB02A	FB04A	FC04A	FC06A		
Applicable Drive (L7□A□□)		L7□A001	L7□A002	L7□A004		L7□A008		
Rated Output	[kW]	0.10	0.20	0.40	0.40	0.60		
Rated torque	[N·m]	0.32	0.64	1.27	1.27	1.91		
	[kgf·cm]	3.25	6.50	12.99	13.00	19.50		
Instantaneous maximum torque	[N·m]	0.96	1.91	3.82	3.82	5.73		
	[kgf·cm]	9.74	19.49	38.98	38.98	58.47		
Rated current	[A]	0.95	1.45	2.60	2.58	3.81		
Maximum current	[A]	2.86	4.35	7.79	7.75	11.42		
Rated rotation speed	[r/min]	3000						
Maximum rotation speed	[r/min]	5000						
Inertia moment	[kg·m <sup>2</sup> ×10 <sup>-4</sup> ]	0.09	0.15	0.25	0.50	0.88		
	[gf·cm·s <sup>2</sup> ]	0.09	0.15	0.25	0.51	0.89		
Allowable load inertia		Motor inertia x 20			Motor inertia x 10			
Rated power rate	[kW/s]	11.38	27.95	65.90	32.62	41.69		
Speed and position detector	Standard	Serial Type 19[bit]						
	Option	X						
Specifications and features	Method of protection	Fully closed-self-cooling IP65 (excluding axis penetration)						
	Time rating	Continuous						
	Ambient temperature	0-40 [°C]						
	Ambient humidity	20-80[%] RH (no condensation)						
	Atmosphere	No direct sunlight, corrosive gas, or combustible gas						
	Anti-vibration	Vibration acceleration 49 [m/s <sup>2</sup> ] (5G)						
Weight	[kg]	0.7	0.9	1.3	1.6	2.2		

◆ Rotation Speed - Torque Characteristics ◆

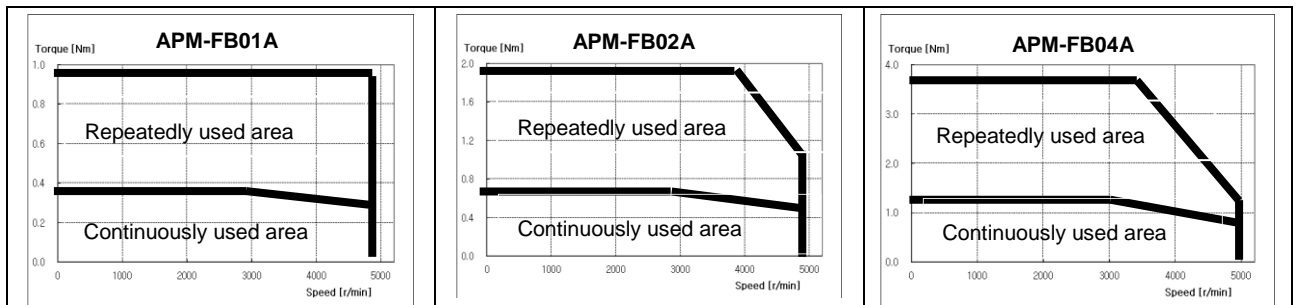

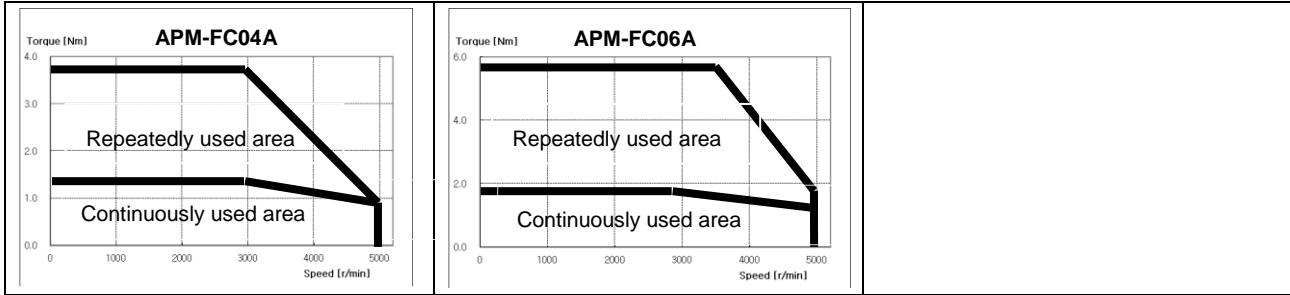

## Product Features

Servo Motor Type (APM-□□□□□)		FC08A	FC10A	FC03D	FC05D	FC06D	FC07D
Applicable Drive (L7□A□□)		L7□A008	L7□A010	L7□A004	L7□A008		
Rated Output	[kW]	0.75	1.00	0.30	0.45	0.55	0.65
Rated torque	[N·m]	2.39	3.18	1.43	2.15	2.60	3.10
	[kgf·cm]	24.36	32.50	14.60	21.90	26.80	31.70
Instantaneous maximum torque	[N·m]	7.16	9.55	4.30	6.45	7.88	9.31
	[kgf·cm]	73.08	97.44	43.80	65.80	80.40	95.00
Rated current	[A]	5.02	6.70	2.50	3.05	3.06	3.83
Maximum current	[A]	15.07	20.09	7.51	9.16	9.18	11.50
Rated rotation speed	[r/min]	3000		2000			
Maximum rotation speed	[r/min]	5000	4500	3000			
Inertia moment	[kg·m <sup>2</sup> ×10 <sup>-4</sup> ]	1.25	1.62	0.50	0.88	1.25	1.62
	[gf·cm·s <sup>2</sup> ]	1.27	1.65	0.51	0.89	1.27	1.65
Allowable load inertia		Motor inertia x 5					
Rated power rate	[kW/s]	45.78	62.74	41.28	52.76	55.39	59.64
Speed and position detector	Standard	x					
	Option	Fully closed-self-cooling IP65 (excluding axis penetration)					
Specifications and features	Method of protection	Continuous					
	Time rating	0-40 [°C]					
	Ambient temperature	20-80[%] RH (no condensation)					
	Ambient humidity	No direct sunlight, corrosive gas, or combustible gas					
	Atmosphere	Vibration acceleration 49 [m/s <sup>2</sup> ] (5G)					
Anti-vibration	x						
Weight	[kg]	2.7	3.8	1.6	2.2	2.7	3.8

### ◆ Rotation Speed - Torque Characteristics ◆

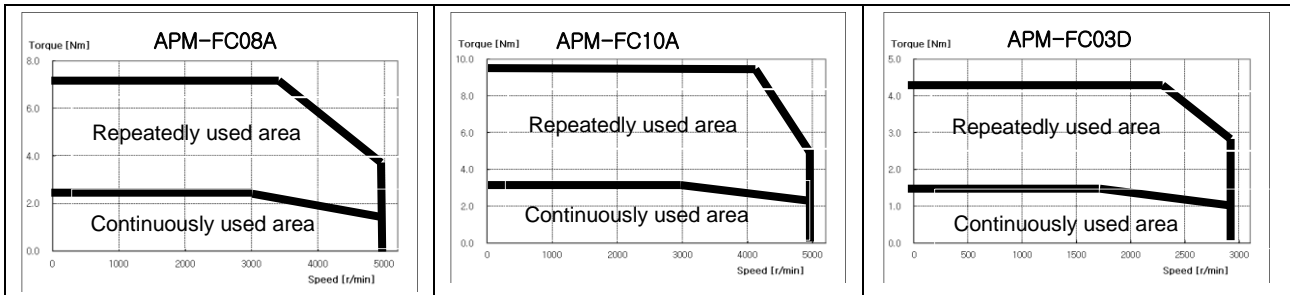



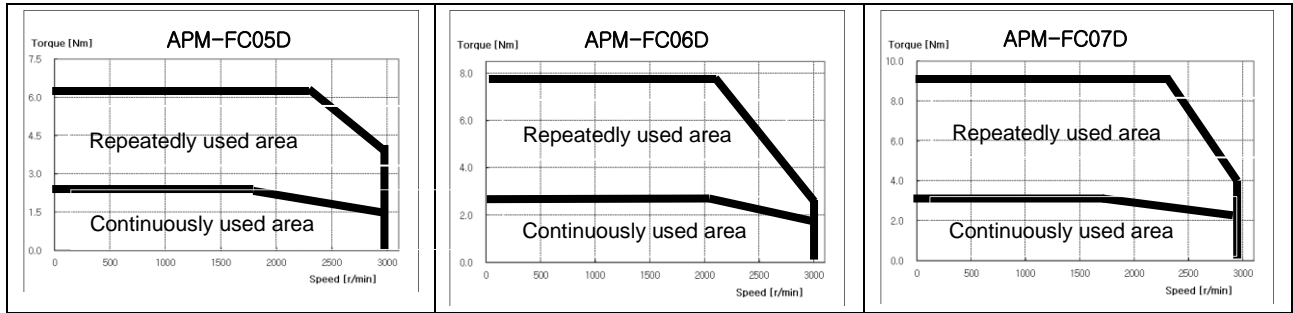

## ■ Product Features

Servo Motor Type (APM-□□□□□)		FE09A	FE15A	FE22A	FE30A	FE06D	FE11D
Applicable Drive (L7□A□□)		L7□A010	L7□A020	L7□A035	L7□A035	L7□A008	L7□A010
Rated output	[kW]	0.9	1.5	2.2	3.0	0.6	1.1
Rated torque	[N·m]	2.86	4.77	7.00	9.55	2.86	5.25
	[kgf·cm]	29.20	48.70	71.40	97.40	29.20	53.60
Maximum instantaneous torque	[N·m]	8.59	14.32	21.01	28.65	8.59	15.75
	[kgf·cm]	87.70	146.10	214.30	292.20	87.70	160.70
Rated current	[A]	6.45	9.15	13.24	16.09	4.56	6.47
Maximum current	[A]	19.35	27.45	39.72	48.27	13.68	19.41
Rated rotation speed	[r/min]	3000				2000	
Maximum rotation speed	[r/min]	5000				3000	
Inertia moment	[kg·m <sup>2</sup> ×10 <sup>-4</sup> ]	5.66	10.18	14.62	19.04	5.66	10.18
	[gf·cm·s <sup>2</sup> ]	5.77	10.39	14.92	19.43	5.77	10.39
Allowable load inertia		Motor inertia x 10					
Rated power rate	[kW/s]	14.47	22.38	33.59	47.85	14.49	27.08
Speed and position detector	Standard	Serial Type 19 [bit]					
	Option	X					
Specifications and features	Protection method	Fully closed-self-cooling IP65(excluding axis penetration)					
	Time rating	Continuous					
	Ambient temperature	0~40[°C]					
	Ambient humidity	20~80[%]RH(no condensation)					
	Atmosphere	No direct sunlight, corrosive gas, or combustible gas					
	Anti-vibration	Vibration acceleration 49[m/s <sup>2</sup> ](5G)					
Weight	[kg]	5.0	6.7	8.5	10.1	5.0	6.7

◆ Rotation speed – Torque Characteristics ◆

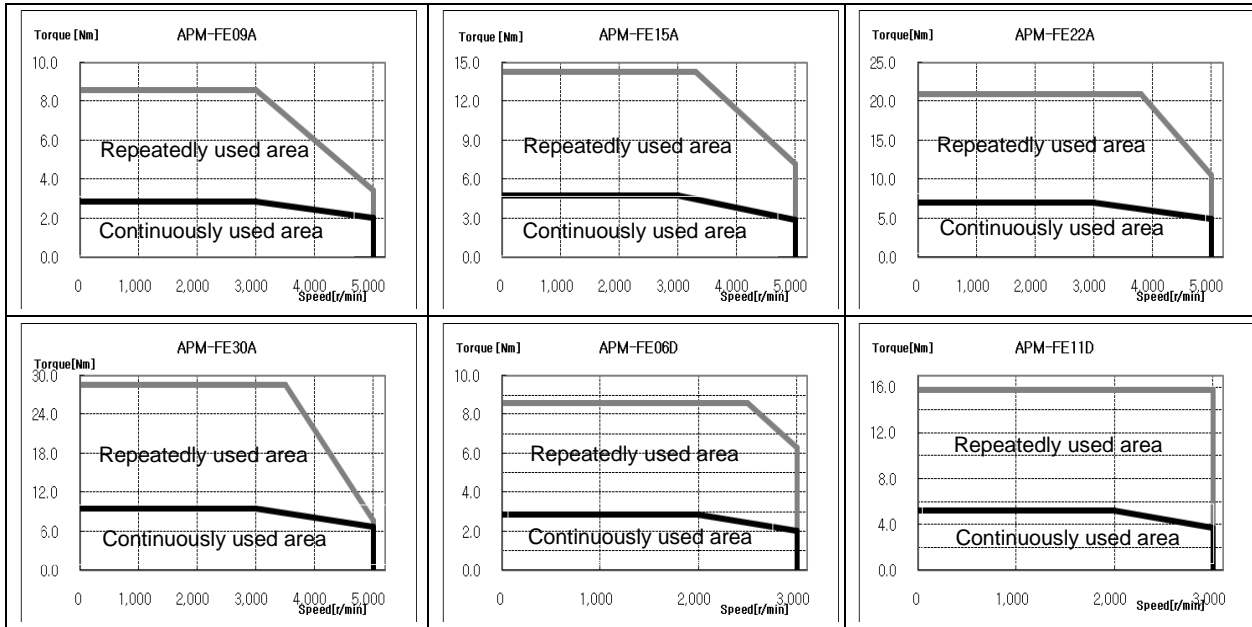

## ■ Product Features

Servo Motor Type (APM-□□□□□)		FE16D	FE22D	FE03M	FE06M	FE09M	FE12M
Applicable Drive (L7□A□□)		L7□A020	L7□A035	L7□A004	L7□A008	L7□A010	L7□A020
Rated output	[kW]	1.6	2.2	0.3	0.6	0.9	1.2
Rated torque	[N·m]	7.63	10.5	2.86	5.72	8.59	11.46
	[kgf·cm]	77.90	107.10	29.22	58.4	87.7	116.9
Maximum instantaneous torque	[N·m]	22.92	31.51	8.59	17.18	25.77	34.22
	[kgf·cm]	233.80	321.40	87.66	175.3	262.9	349.1
Rated current	[A]	10.98	12.97	2.73	4.56	6.18	10.67
Maximum current	[A]	32.94	38.91	8.19	13.68	18.54	32.01
Rated rotation speed	[r/min]	2000		1000			
Maximum rotation speed	[r/min]	3000		2000			
Inertia moment	[kg·m <sup>2</sup> ×10 <sup>-4</sup> ]	14.62	19.04	5.66	10.18	14.62	19.04
	[gf·cm·s <sup>2</sup> ]	14.92	19.43	5.77	10.39	14.92	19.43
Allowable load inertia		Motor inertia x 10					
Rated power rate	[kW/s]	39.89	57.90	14.49	32.22	50.48	68.91
Speed and position detector	Standard	Serial Type 19 [bit]					
	Option	X					
Specifications and features	Protection method	Fully closed: self-cooling IP65(excluding axis penetration)					
	Time rating	Continuous					
	Ambient temperature	0~40[°C]					
	Ambient humidity	20~80[%]RH(no condensation_					
Atmosphere	No direct sunlight, corrosive gas, or combustible gas						

	Anti-vibration	Vibration acceleration 49[m/s <sup>2</sup> ](5G)					
Weight	[kg]	8.5	10.1	5.0	6.7	8.5	10.1

◆ Rotation speed – Torque Characteristics ◆

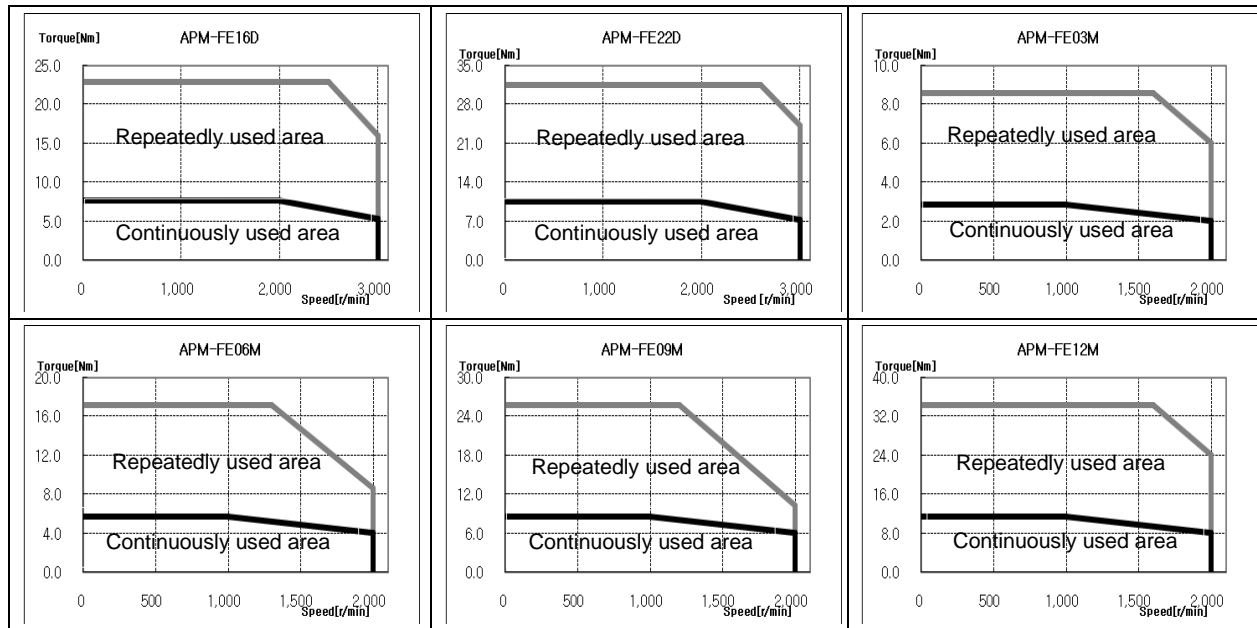

## Product Features

Servo Motor Type (APM-□□□□□)		FE05G	FE09G	FE13G	FE17G	FF30A	FF50A
Applicable Drive (L7□A□□)		L7□A008	L7□A010	L7□A020		L7□A035	L7□A050
Rated output	[kW]	0.45	0.85	1.3	1.7	3.0	5.0
Rated torque	[N·m]	2.86	5.41	8.27	10.82	9.55	15.91
	[kgf·cm]	29.22	55.19	84.41	110.38	97.40	162.30
Maximum instantaneous torque	[N·m]	8.59	16.23	24.82	32.46	28.65	47.74
	[kgf·cm]	87.66	165.57	253.23	331.14	292.3	487.00
Rated current	[A]	4.56	6.67	11.90	13.36	15.26	26.47
Maximum current	[A]	13.68	20.01	35.7	40.08	45.78	79.41
Rated rotation speed	[r/min]	1500				3000	
Maximum rotation speed	[r/min]	3000				5000	
Inertia moment	[kg·m <sup>2</sup> ×10 <sup>-4</sup> ]	5.66	10.18	14.62	19.04	27.96	46.56
	[gf·cm·s <sup>2</sup> ]	5.77	10.39	14.92	19.43	28.53	47.51
Allowable load inertia		Motor inertia x 10				Motor inertia x 5	
Rated power rate	[kW/s]	14.49	28.74	46.81	61.46	32.59	54.33
Speed and position detector	Standard	Serial Type 19 [bit]					
	Option	X					
Specifications and features	Protection method	Fully closed-self-cooling IP65(excluding axis penetration)					
	Time rating	Continuous					
	Ambient temperature	0~40[°C]					

	Ambient humidity	20~80[%]RH(no condensation)					
	Atmosphere	No direct sunlight, corrosive gas, or combustible gas					
	Anti-vibration	Vibration acceleration 49[m/s <sup>2</sup> ](5G)					
Weight	[kg]	5.0	6.7	8.5	10.1	12.5	17.4

◆ Rotation speed – Torque Characteristics ◆

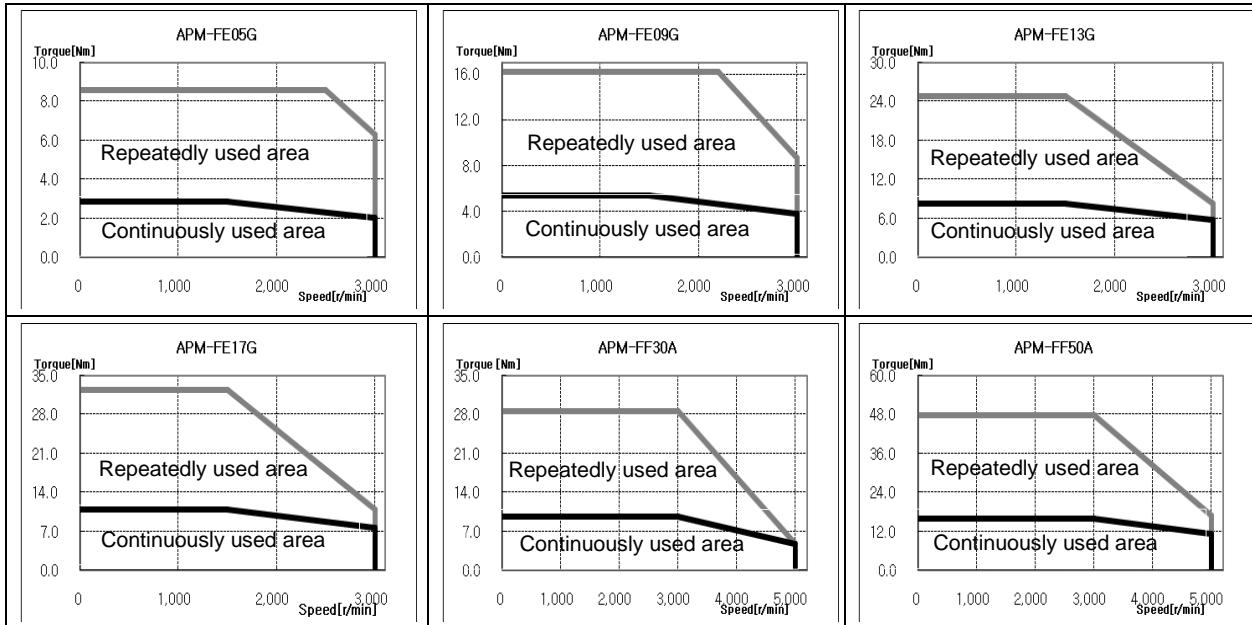

## ■ Product Features

Servo Motor Type (APM-□□□□□)		FF22D	FF35D	FF55D	FF20G	FF30G	FF44G
Applicable Drive (L7□A□□)		L7□A020	L7□A035	L7□A050	L7□A020	L7□A035	L7□A050
Rated output	[kW]	2.2	3.5	5.5	1.8	2.9	4.4
	[N·m]	10.50	16.70	26.25	11.45	18.46	28.00
Rated torque	[kgf·cm]	107.1	170.4	267.8	116.9	188.3	285.7
	[N·m]	31.50	50.10	78.76	34.35	55.38	84.03
Maximum instantaneous torque	[kgf·cm]	321.30	511.40	803.4	350.60	564.90	857.10
	[A]	13.07	16.48	28.78	12.16	15.98	30.70
Maximum current	[A]	39.21	49.44	86.34	36.48	47.94	92.10
Rated rotation speed	[r/min]	2000			1500		
Maximum rotation speed	[r/min]	3000			3000	2700	3000
Inertia moment	[kg·m <sup>2</sup> ×10 <sup>-4</sup> ]	27.96	46.56	73.85	27.96	46.56	73.85
	[gf·cm·s <sup>2</sup> ]	28.53	47.51	75.36	28.53	47.51	75.36
Allowable load inertia		Motor inertia x 5					
Rated power rate	[kW/s]	39.43	59.89	93.27	46.92	73.14	106.15
Speed and position detector	Standard	Serial Type 19 [bit]					
	Option	X					
Specifications and features	Protection method	Fully closed-self-cooling IP65(excluding axis penetration)					
	Time rating	Continuous					

	Ambient temperature	0~40[°C]					
	Ambient humidity	20~80[%]RH(no condensation)					
	Atmosphere	No direct sunlight, corrosive gas, or combustible gas					
	Anti-vibration	Vibration acceleration 49[m/s <sup>2</sup> ](5G)					
Weight	[kg]	12.5	17.4	25.12	12.5	17.4	25.2

◆ Rotation speed – Torque Characteristics ◆

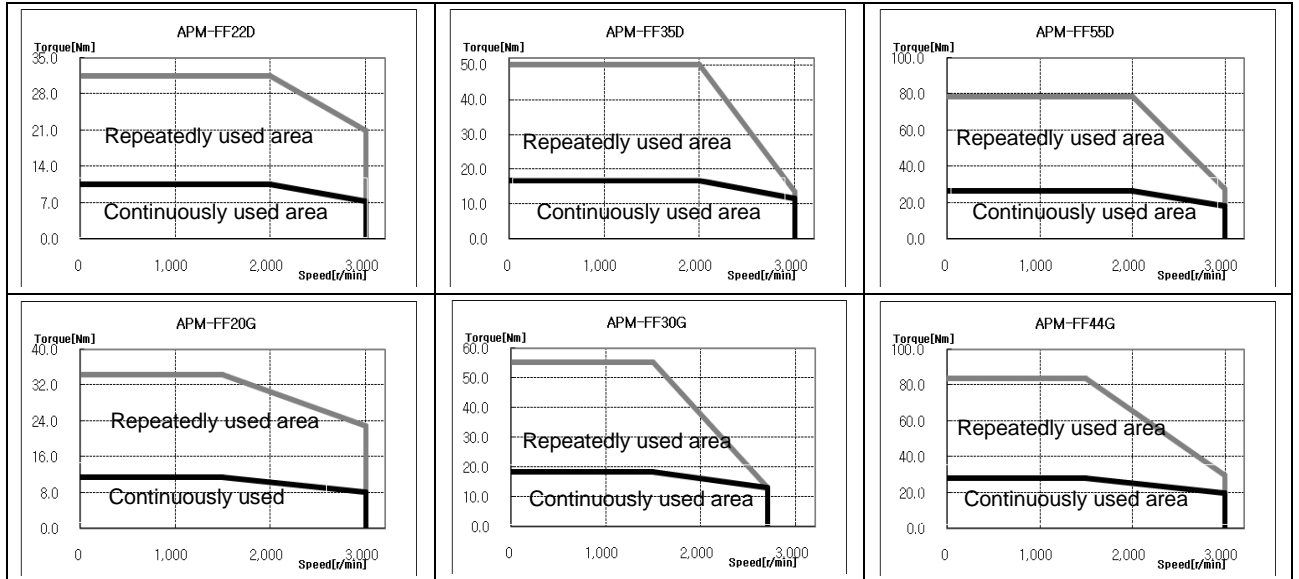

■ Protect Features

Servo Motor Type (APM-□□□□□)		FF12M	FF20M	FF30M	FF44M		
Applicable Drive (L7□A□□)		L7□A020	L7□A020	L7□A035	L7□A050		
Rated output	[kW]	1.2	2.0	3.0	4.4		
Rated torque	[N·m]	11.46	19.09	28.64	42.02		
	[kgf·cm]	116.9	194.8	292.2	428.7		
Maximum instantaneous torque	[N·m]	34.38	57.29	85.94	126.1		
	[kgf·cm]	350.70	584.40	876.60	128.60		
Rated current	[A]	11.01	12.96	16.58	30.60		
Maximum current	[A]	33.03	38.88	49.74	91.8		
Rated rotation speed	[r/min]	1000					
Maximum rotation speed	[r/min]	2000		1700	2000		
Inertia moment	[kg·m <sup>2</sup> ×10 <sup>-4</sup> ]	27.96	46.56	73.85	106.7		
	[gf·cm·s <sup>2</sup> ]	28.53	47.51	75.36	108.9		
Allowable load inertia		Motor inertia x 5					
Rated power rate	[kW/s]	46.94	78.27	111.04	165.38		
Speed and position detector	Standard	Serial Type 19 [bit]					
	Option	X					

Specifications and features	Protection method	Fully closed self-cooling IP65(excluding axis penetration)			
	Time rating	Continuous			
	Ambient temperature	0~40[°C]			
	Ambient humidity	20~80[%]RH(no condensation)			
	Atmosphere	No direct sunlight, corrosive gas, or combustible gas			
	Anti-vibration	Vibration acceleration 49[m/s <sup>2</sup> ](5G)			
Weight	[kg]	12.5	17.4	25.2	33.8

◆ Rotation speed – Torque Characteristics ◆

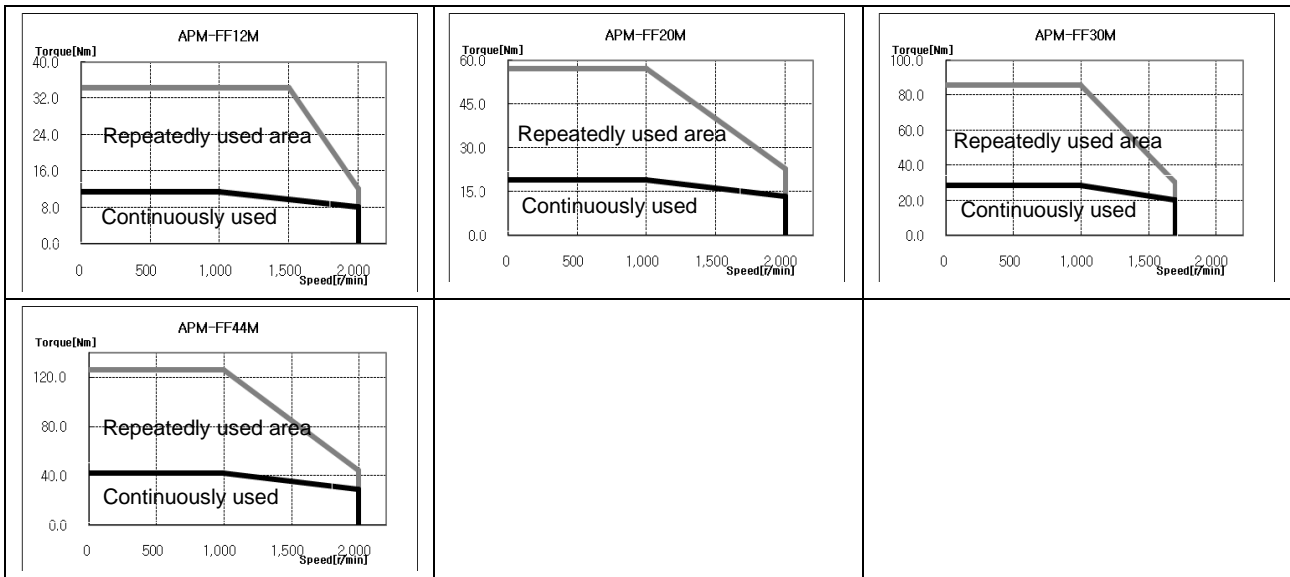

## ■ Protect Features

Servo Motor Type (APM-□□□□□)		FG22D	FG35D	FG55D	FG20G	FG30G	FG44G
Applicable Drive (L7□A□□)		L7□A020	L7□A035	L7□A050	L7□A020	L7□A035	L7□A050
Rated output	[kW]	2.2	3.5	5.5	1.8	2.9	4.4
	[N·m]	10.50	16.71	26.25	11.50	18.50	28.00
Rated torque	[kgf·cm]	107.1	170.4	267.8	116.9	188.4	285.8
	[N·m]	31.51	50.12	78.76	34.40	55.40	84.00
Maximum instantaneous torque	[kgf·cm]	321.30	511.30	803.4	350.80	565.1	857.4
	[A]	10.25	14.67	29.74	11.18	16.21	31.72
Maximum current	[A]	30.75	44.01	89.22	33.54	48.63	95.16
Rated rotation speed	[r/min]	2000			1500		
Maximum rotation speed	[r/min]	3000	2700	3000	3000	2700	3000
Inertia moment	[kg·m <sup>2</sup> ×10 <sup>-4</sup> ]	41.13	71.53	117.72	14.13	71.53	117.72
	[gf·cm·s <sup>2</sup> ]	41.97	72.99	120.12	41.97	72.99	120.12
Allowable load inertia		Motor inertia x 5					
Rated power rate	[kW/s]	26.78	38.99	58.51	31.91	47.66	66.64

Speed and position detector	Standard	Serial Type 19 [bit]					
	Option	X					
Specifications and features	Protection method	Fully closed-self-cooling IP65(excluding axis penetration)					
	Time rating	Continuous					
	Ambient temperature	0~40[°C]					
	Ambient humidity	20~80[%]RH(no condensation)					
	Atmosphere	No direct sunlight, corrosive gas, or combustible gas					
	Anti-vibration	Vibration acceleration 49[m/s <sup>2</sup> ](5G)					
Weight	[kg]	15.4	20.2	28.12	15.4	20.2	28.0

◆ Rotation speed – Torque Characteristics ◆

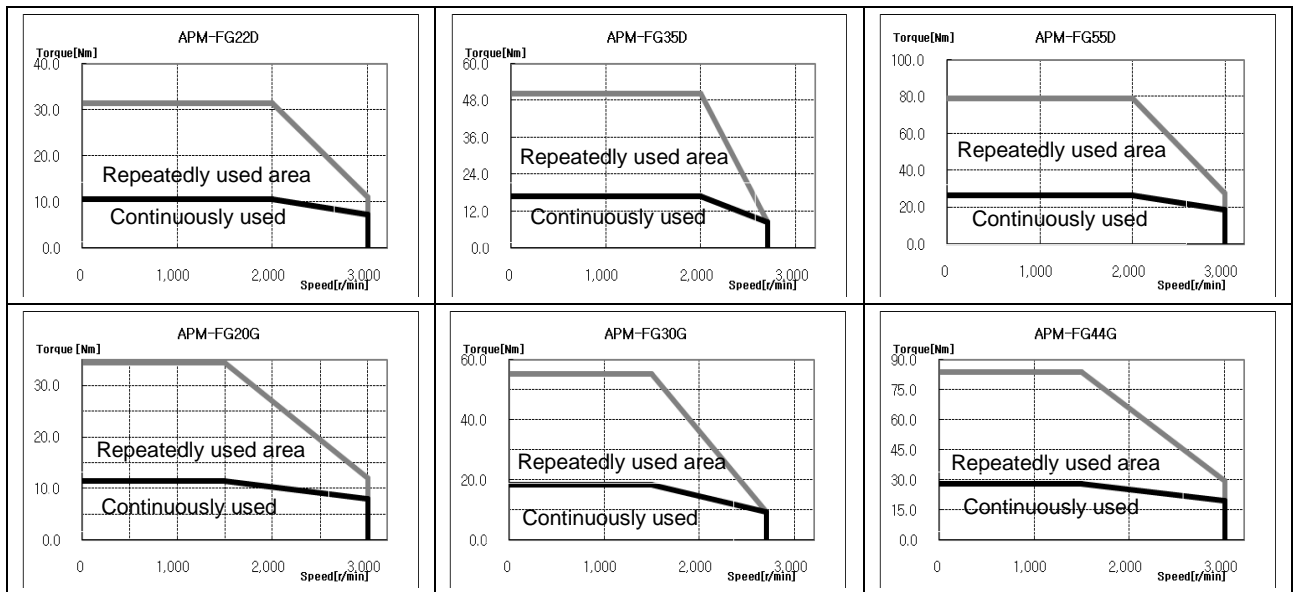

■ Product Features

Servo Motor Type (APM-□□□□□)		FG12M	FG20M	FG30M	FG44M		
Applicable Drive (L7□A□□)		L7□A020		L7□A035	L7□A050		
Rated output	[kW]	1.2	2.0	3.0	4.4		
Rated torque	[N·m]	11.50	19.10	28.60	42.00		
	[kgf·cm]	116.9	194.9	292.3	428.7		
Maximum instantaneous torque	[N·m]	34.40	57.30	85.90	126.00		
	[kgf·cm]	350.8	584.6	876.9	128.61		
Rated current	[A]	11.28	13.10	15.52	27.26		
Maximum current	[A]	33.84	39.3	46.56	81.78		
Rated rotation speed	[r/min]	1000					
Maximum rotation speed	[r/min]	2000		1700	2000		
Inertia moment	[kg·m <sup>2</sup> ×10 <sup>-4</sup> ]	41.13	71.53	117.72	149.40		

	[gf·cm·s <sup>2</sup> ]	41.97	72.99	120.12	152.45		
Allowable load inertia		Motor inertia x 5					
Rated power rate	[kW/s]	31.91	51.00	69.70	118.14		
Speed and position detector	Standard	Serial Type 19 [bit]					
	Option	X					
Specifications and features	Protection method	Fully closed-self-cooling IP65(excluding axis penetration)					
	Time rating	Continuous					
	Ambient temperature	0~40[°C]					
	Ambient humidity	20~80[%]RH(no condensation)					
	Atmosphere	No direct sunlight, corrosive gas, or combustible gas					
	Anti-vibration	Vibration acceleration 49[m/s <sup>2</sup> ](5G)					
Weight	[kg]	15.4	20.2	28.0	33.5		

◆ Rotation speed – Torque Characteristics ◆

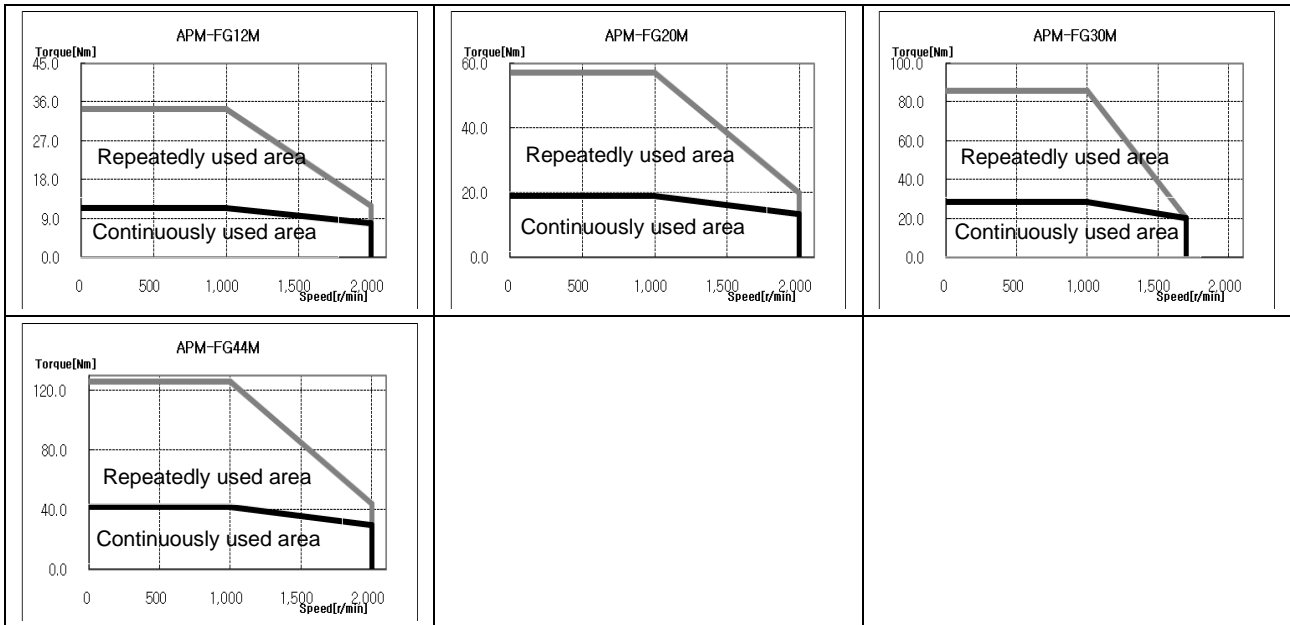

■ Product Features

Servo Motor Type (APM-□□□□□)		FALR5A	FAL01A	FAL015A	FBL01A	FBL02A	FBL04A
Applicable Drive (L7□A□□)		L7□A001		L7□A002	L7□A001	L7□A002	L7□A004
Rated output	[kW]	0.05	0.10	0.15	0.10	0.20	0.40
Rated torque	[N·m]	0.16	0.32	0.48	0.32	0.64	1.27
	[kgf·cm]	1.62	3.25	4.87	3.25	6.49	12.99
Maximum instantaneous torque	[N·m]	0.48	0.96	1.43	0.96	1.91	3.82
	[kgf·cm]	4.87	9.74	14.62	9.74	19.48	38.96
Rated current	[A] <sub>φ.ac.rms</sub>	0.95	1.25	1.76	0.95	1.45	2.60
Maximum current	[A] <sub>φ.ac.rms</sub>	2.85	3.75	5.28	2.85	4.35	7.80



Rated rotation speed	[r/min]	3000					
Maximum rotation speed	[r/min]	5000					
Inertia moment	[kg·m <sup>2</sup> ×10 <sup>-4</sup> ]	0.023	0.042	0.063	0.091	0.147	0.248
	[gf·cm·s <sup>2</sup> ]	0.024	0.043	0.065	0.093	0.150	0.253
Allowed load inertia		Motor inertia x 30			Motor inertia Motor inertia x 20		
Rated power rate	[kW/s]	10.55	23.78	35.34	11.09	27.60	27.07
Speed and position detector	Standard	Serial Multi-Turn Built-in Type(18bit)			Serial Multi-Turn Built-in Type(19bit)		
	Option	x					
Specifications and features	Protection method	Fully closed-self-cooling IP67(excluding axis penetration)					
	Time rating	Continuous					
	Ambient temperature	0~40[°C]					
	Ambient humidity	20~80[%]RH(no condensation)					
	Atmosphere	No direct sunlight, corrosive gas, or combustible gas					
	Anti-vibration	Vibration acceleration 49[m/s <sup>2</sup> ](5G)					
Weight	[kg]	0.31	0.45	0.61	0.56	0.74	1.06

◆ Rotation speed – Torque Characteristics ◆

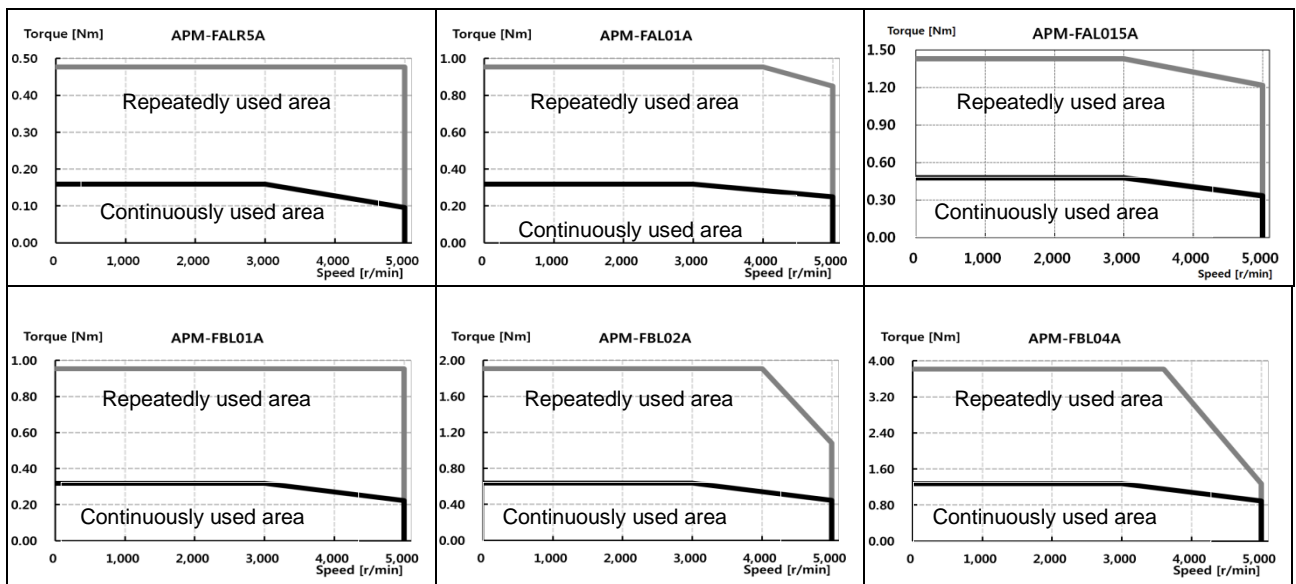

■ Product Features

Servo Motor Type (APM-□□□□□)	FCL04A	FCL06A	FCL08A	FCL10A		
Applicable Drive (L7□A□□)	L7□A004	L7□A008		L7□A010		
Rated output	[kW]	0.40	0.60	0.75	1.00	
Rated torque	[N·m]	1.27	1.91	2.39	3.18	

	[kgf·cm]	12.99	19.49	24.36	32.48		
Maximum instantaneous torque	[N·m]	3.82	5.73	7.16	9.55		
	[kgf·cm]	38.98	58.47	73.08	97.44		
Rated current	[A] <sub>φ.ac.rms</sub>	2.58	3.81	5.02	5.83		
Maximum current	[A] <sub>φ.ac.rms</sub>	7.75	11.42	15.07	17.50		
Rated rotation speed	[r/min]	3000					
Maximum rotation speed	[r/min]	5000					
Inertia moment	[kg·m <sup>2</sup> ×10 <sup>-4</sup> ]	0.530	0.897	1.264	1.632		
	[gf·cm·s <sup>2</sup> ]	0.541	0.915	1.290	1.665		
Allowed load inertia							
Rated power rate	[kW/s]	30.60	40.66	45.09	62.08		
Speed and position detector	Standard	Serial Multi-Turn Built-in Type(19bit)					
	Option	x					
Specifications and features	Protection method	Fully closed-self-cooling IP67(excluding axis penetration)					
	Time rating	Continuous					
	Ambient temperature	0~40[°C]					
	Ambient humidity	20~80[%]RH(no condensation)					
	Atmosphere	No direct sunlight, corrosive gas, or combustible gas					
	Anti-vibration	Vibration acceleration 49[m/s <sup>2</sup> ](5G)					
Weight	[kg]	1.52	2.14	2.68	3.30		

◆ Rotation speed – Torque Characteristics ◆

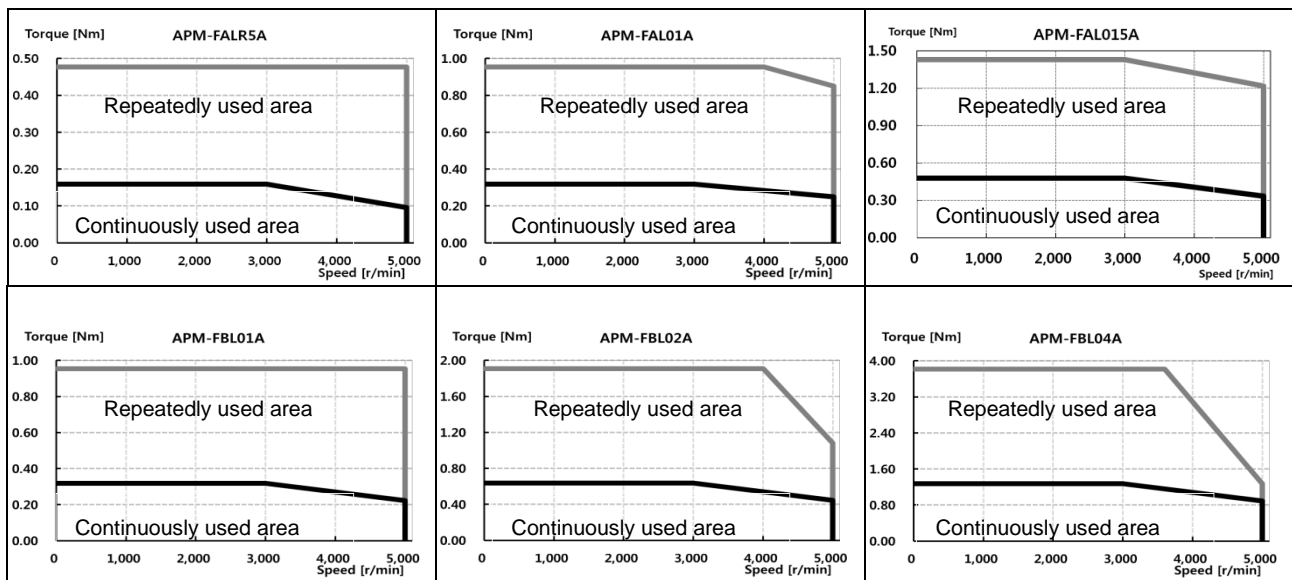

## ■ Product Features

Servo Motor Type (APM-□□□□□)		FCL04A	FCL06A	FCL08A	FCL10A		
Applicable Drive (L7□A□□)		L7□A004	L7□A008		L7□A010		
Rated output	[kW]	0.40	0.60	0.75	1.00		
Rated torque	[N·m]	1.27	1.91	2.39	3.18		
	[kgf·cm]	12.99	19.49	24.36	32.48		
Maximum instantaneous torque	[N·m]	3.82	5.73	7.16	9.55		
	[kgf·cm]	38.98	58.47	73.08	97.44		
Rated current	[A] <sub>φ.ac.rms</sub>	2.58	3.81	5.02	5.83		
Maximum current	[A] <sub>φ.ac.rms</sub>	7.75	11.42	15.07	17.50		
Rated rotation speed	[r/min]	3000					
Maximum rotation speed	[r/min]	5000					
Inertia moment	[kg·m <sup>2</sup> ×10 <sup>-4</sup> ]	0.530	0.897	1.264	1.632		
	[gf·cm·s <sup>2</sup> ]	0.541	0.915	1.290	1.665		
Allowed load inertia							
Rated power rate	[kW/s]	30.60	40.66	45.09	62.08		
Speed and position detector	Standard	Serial Multi-Turn Built-in Type(19bit)					
	Option	x					
Specifications and features	Protection method	Fully closed-self-cooling IP67(excluding axis penetration)					
	Time rating	Continuous					
	Ambient temperature	0~40[°C]					
	Ambient humidity	20~80[%]RH(no condensation)					
	Atmosphere	No direct sunlight, corrosive gas, or combustible gas					
	Anti-vibration	Vibration acceleration 49[m/s <sup>2</sup> ](5G)					
Weight	[kg]	1.52	2.14	2.68	3.30		

### ◆ Rotation speed – Torque Characteristics ◆

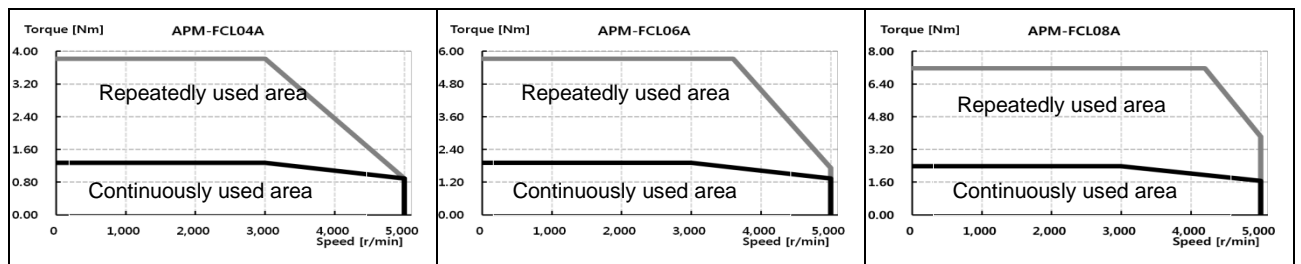

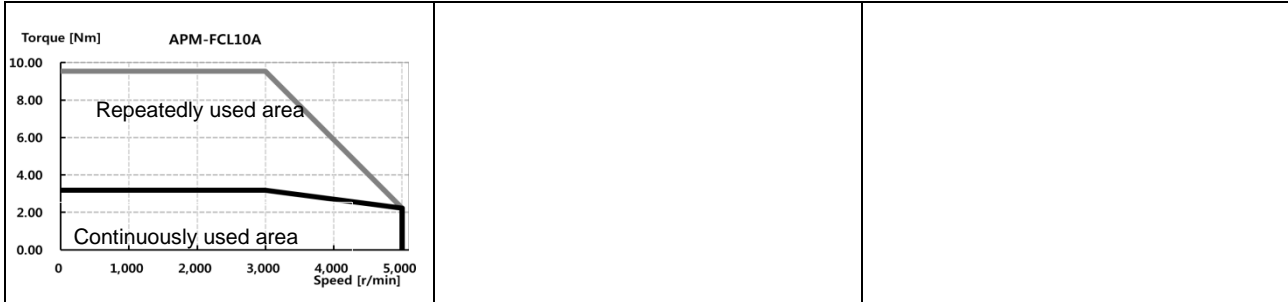

## ■ Product Features

Servo Motor Type (APM-□□□□□)		FCL03D	FCL05D	FCL06D	FCL07D			
Applicable Drive (L7□A□□)		L7□A004	L7□A008					
Rated output	[kW]	0.30	0.45	0.55	0.65			
Rated torque	[N·m]	1.43	2.15	2.63	3.10			
	[kgf·cm]	14.62	21.92	26.80	31.67			
Maximum instantaneous torque	[N·m]	4.30	6.45	7.88	9.31			
	[kgf·cm]	43.85	65.77	80.39	95.01			
Rated current	[A] <sub>φ.ac.rms</sub>	2.50	3.05	3.06	3.83			
Maximum current	[A] <sub>φ.ac.rms</sub>	7.51	9.16	9.18	11.50			
Rated rotation speed	[r/min]	2000						
Maximum rotation speed	[r/min]	3000						
Inertia moment	[kg·m <sup>2</sup> ×10 <sup>-4</sup> ]	0.530	0.897	1.264	1.63			
	[gf·cm·s <sup>2</sup> ]	0.541	0.915	1.290	1.66			
Allowed load inertia								
Rated power rate	[kW/s]	38.73	51.47	54.56	59.03			
Speed and position detector	Standard	Serial Multi-Turn Built-in Type(19bit)						
	Option	x						
Specifications and features	Protection method	Fully closed-self-cooling IP67(excluding axis penetration)						
	Time rating	Continuous						
	Ambient temperature	0~40[°C]						
	Ambient humidity	20~80[%]RH(no condensation)						
	Atmosphere	No direct sunlight, corrosive gas, or combustible gas						
	Anti-vibration	Vibration acceleration 49[m/s <sup>2</sup> ](5G)						
Weight	[kg]	1.26	2.12	2.66	2.78			

◆ Rotation speed – Torque Characteristics ◆

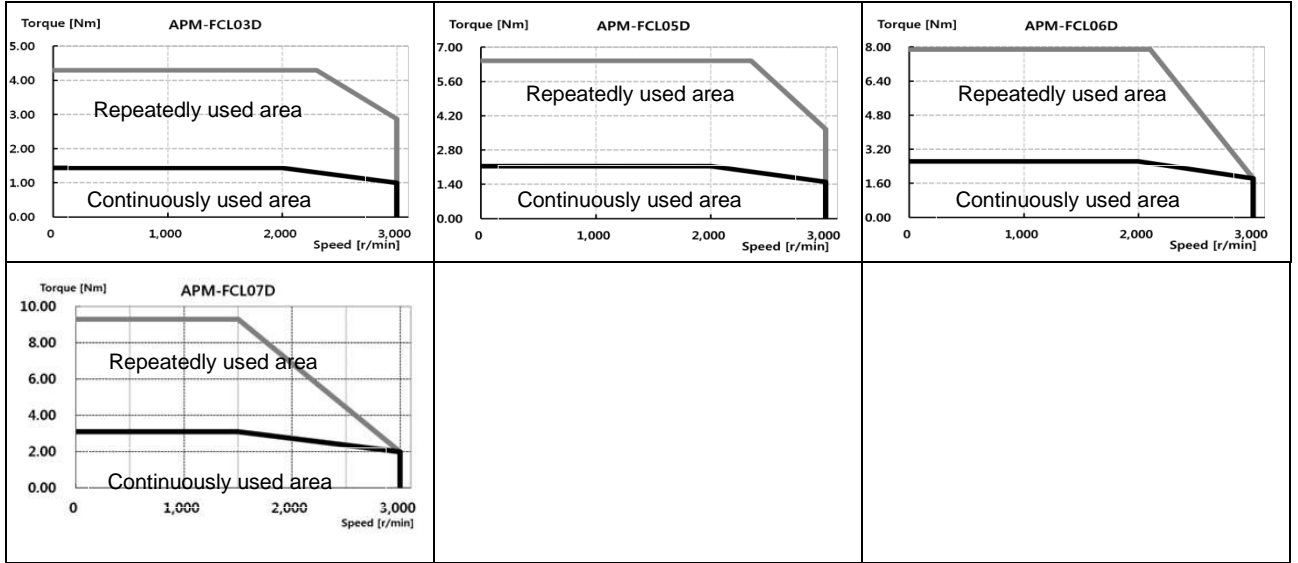

■ Electric Brake Specifications

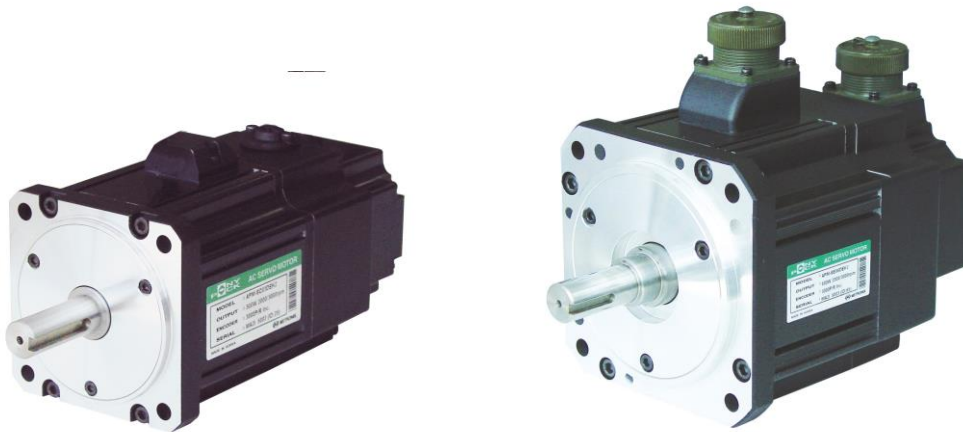

Applicable Motor Series	APM-SA	APM-SB	APM-SC	APM-SE	APM-SF	APM-SG
Purpose	Maintenance of stop(Refer to Note 2 below)					
Input voltage [V]	DC 24V					DC 90V
Static friction torque [N·m]	0.32	1.47	3.23	10.4	40	74
Capacity [W]	6	6.5	9	19.4	25	32
Coil resistance [Ω]	96	89	64	29.6	23	327
Rated current [A]	0.25	0.27	0.38	0.81	1.04	0.28
Braking mechanism	Spring brake					
Insulation grade	Grade F					
Applicable Motor Series	APM-FB	APM-FC				
Purpose	Maintenance of stop(Refer to Note 2 below)					
Input voltage [V]	DC 24V					
Static friction torque [N·m]	1.47	3.23				
Capacity [W]	6.5	9				
Coil resistance [Ω]	89	64				
Rated current [A]	0.27	0.38				
Braking mechanism	Spring brake					
Insulation grade	Grade F					

- Note 1)** The same specifications apply to all electric brakes installed in our servo motors.
- Note 2)** Electric brakes are designed to maintain a stop. Never use them for absolute braking.
- Note 3)** The characteristics of the electric brakes were measured at 20°C.
- Note 4)** These brake specifications are subject to change. Check the voltage specifications on your specific motor.

### 10.1.3 Outline Diagram (For the drawing of Oilseal Type, it is available on request)

#### ■ SA Series | APM-SAR3A, APM-SAR5A, APM-SA01A, APM-SA015A

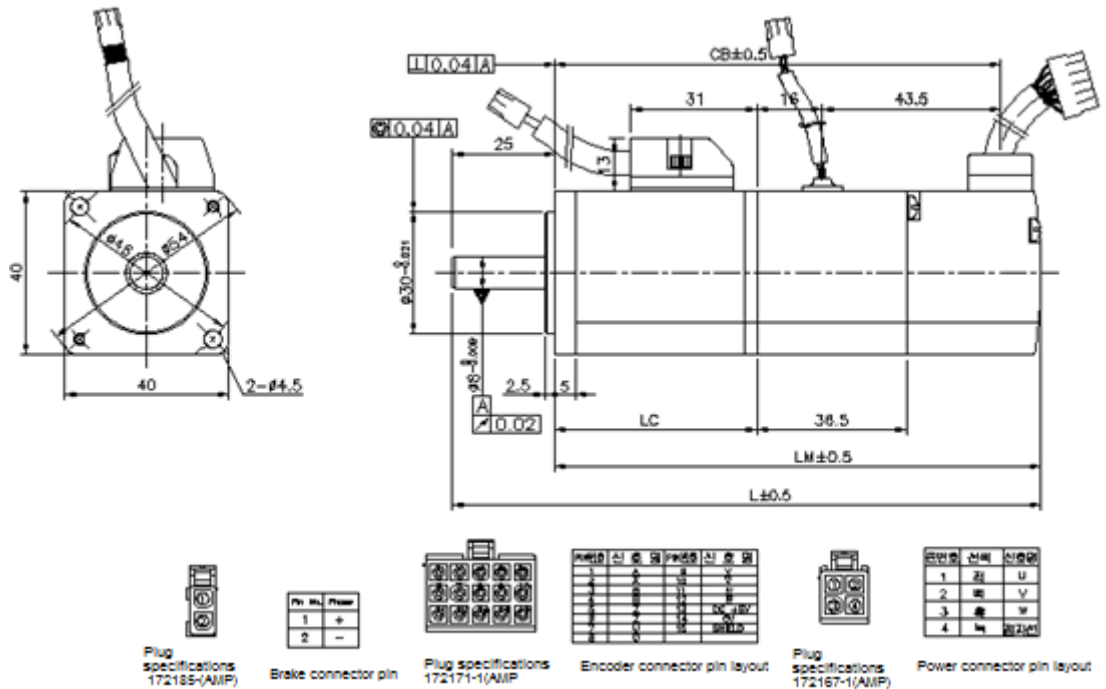

Name	External Dimensions				Weight (kg)
	L	LM	LC	CB	
SAR3A	101.3(137.6)	76.3(112.6)	42.5(102.3)	66.3(102.3)	0.32(0.67)
SAR5A	108.3(144.6)	83.3(119.6)	49.5(49.4)	73.3(109.3)	0.38(0.73)
SA01A	125.3(161.6)	100.3(66.4)	66.5(66.4)	90.3(126.3)	0.5(0.85)
SA015A	145.3	120.3	86.5	110.3	0.7

**Note 1)** The standard shaft end for 40 flange model is a straight shaft end.

**Note 2)** Use DC power (24 V) to operate the brake.

**Note 3)** The sizes in parentheses apply when attached to the brakes.(Except SA015A)

**Note 4)** Option specification: Serial M-Turn Encoder PinMap

<Serial M-turn Encoder Connector>

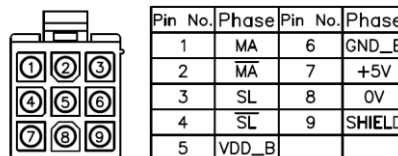

Plug : 172169-1(AMP)





■ **SC Series | APM-SC04A,SC03D, APM-SC06A,SC05D, APM-SC08A,SC06D, APM-SC10A,SC07D**

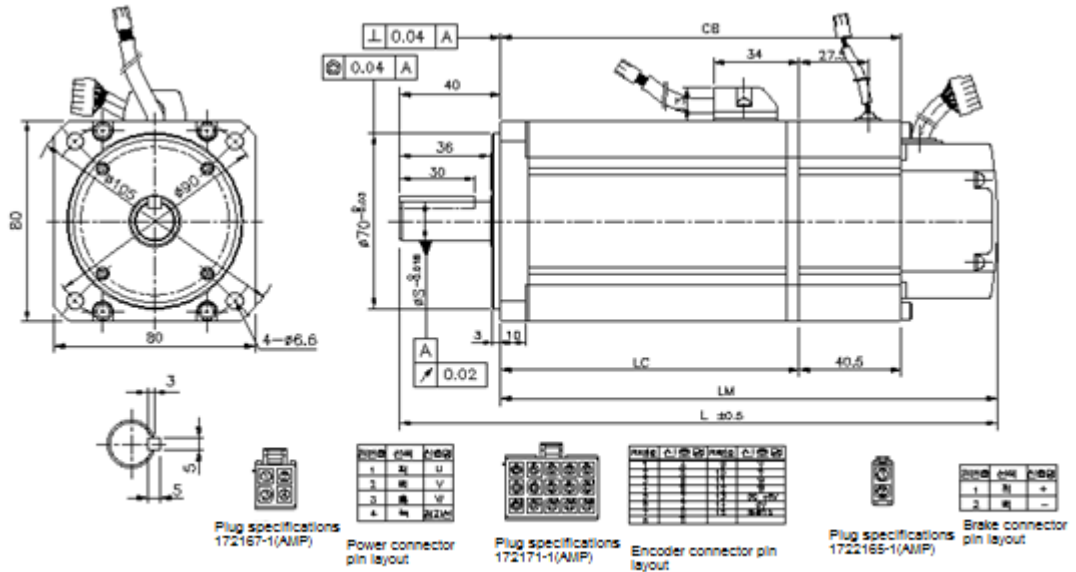

Name	External Dimensions					Weight (kg)
	L	LM	LC	CB	S	
SC04A, SC03D	158.5(198.5)	118.5(158.5)	79(78.8)	86(126.5)	14	1.88(2.92)
SC06A, SC05D	178.5(218.5)	138.5(178.5)	99(98.8)	106(146.5)	16	2.52(3.56)
SC08A, SC06D	198.5(238.5)	158.5(198.5)	119(118.8)	126(166.5)	16	3.15(4.22)
SC10A, SC07D	218.5(258.5)	178.5(218.5)	139(138.8)	146(186.5)	16	3.80(4.94)

**Note 1)** Use DC power (24 V) to operate the brake.

**Note 2)** The sizes in parentheses apply when attached to the brakes.

**Note 3)** Option specification: Serial M-Turn Encoder PinMap

<Serial S-turn Encoder Connector>

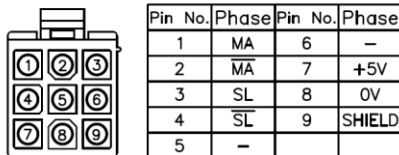

Plug : 172169-1(AMP)

<Serial M-turn Encoder Connector>

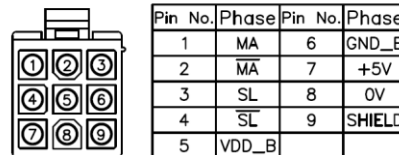

Plug : 172169-1(AMP)

■ **SE Series | APM-SE09A, SE06D, SE05G, SE03M, APM-SE15A, SE11D, SE09G, SE06M, APM-SE22A, SE16D, SE13G, SE09M, APM-SE30A, SE22D, SE17G, SE12M**

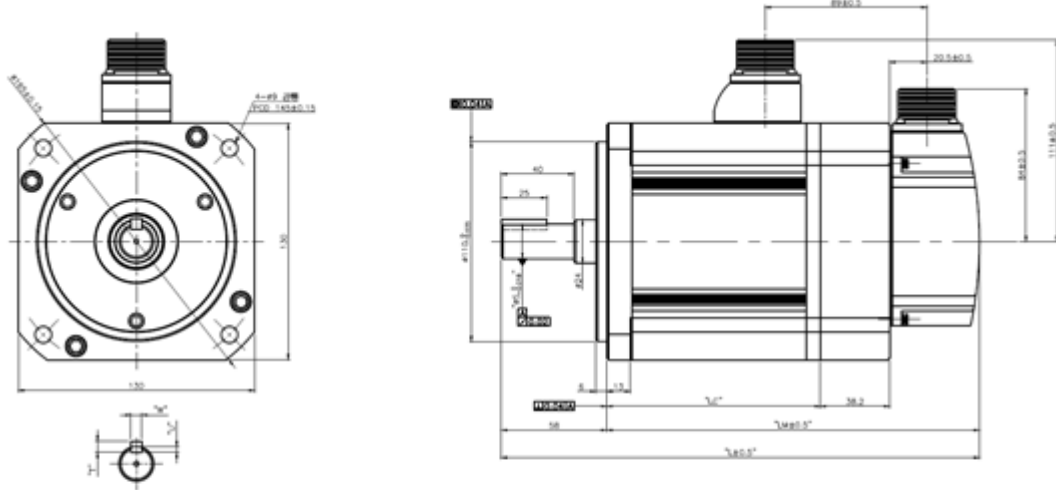

Plug specifications MS3102A20-4P

Pin No.	Phase
A	U
B	V
C	W
D	Ground

Power connector pin layout



Plug specifications MS3102A20-15P

DBB	DBR
A	U
B	V
C	W
D	SL
E	SK+
F	SK-

Brake connector pin layout



Plug specifications MS3102A20-25P

Pin No.	Phase	Pin No.	Phase
1	A	11	U
2	B	12	V
3	C	13	W
4	D	14	SL
5	E	15	SK+
6	F	16	SK-
7	G	17	MA
8	H	18	MA
9	I	19	MA
10	J	20	MA
11	K	21	MA
12	L	22	MA
13	M	23	MA
14	N	24	MA
15	O	25	MA

Encoder connector pin layout

Name	External Dimensions			Key Dimensions				Weight (Kg)
	L	LM	LC	S	T	W	U	
SE09A,SE06D,SE05G,SE03M	201.3(239.3)	143.3(181.3)	93.8(93.6)	19	5	5	3	5.5(7.04)
SE15A,SE11D,SE09G,SE06M	225.3(263.3)	167.3(205.3)	117.8(117.6)	19	5	5	3	7.54(9.08)
SE22A,SE16D,SE13G,SE09M	249.3(287.3)	191.3(229.3)	141.8(141.6)	22	6	6	3.5	9.68(11.22)
SE30A,SE22D,SE17G,SE12M	273.3(311.3)	215.3(253.3)	165.8(165.6)	22	6	6	3.5	11.78(13.32)

- Note 1)** Use DC power (24 V) to operate the brake.
- Note 2)** The sizes in parentheses apply when attached to the brakes.
- Note 3)** Option specification: Serial M-Turn Encoder PinMap

<Serial S–turn Encoder Connector>



Pin No.	Phase	Pin No.	Phase
1	MA	6	-
2	MA	7	+5V
3	SL	8	0V
4	SL	9	SHIELD
5	-		

Plug : 172169-1(AMP)

<Serial M–turn Encoder Connector>



Pin No.	Phase	Pin No.	Phase
1	MA	6	GND_B
2	MA	7	+5V
3	SL	8	0V
4	SL	9	SHIELD
5	VDD_B		

Plug : 172169-1(AMP)

**■ SF Series | APM-SF30A, SF22D, SF20G, SF12M,  
APM-SF50A, LF35D, LF30G, SF20M,  
APM-SF55D, SF44G, LF30M  
APM-SF44M**

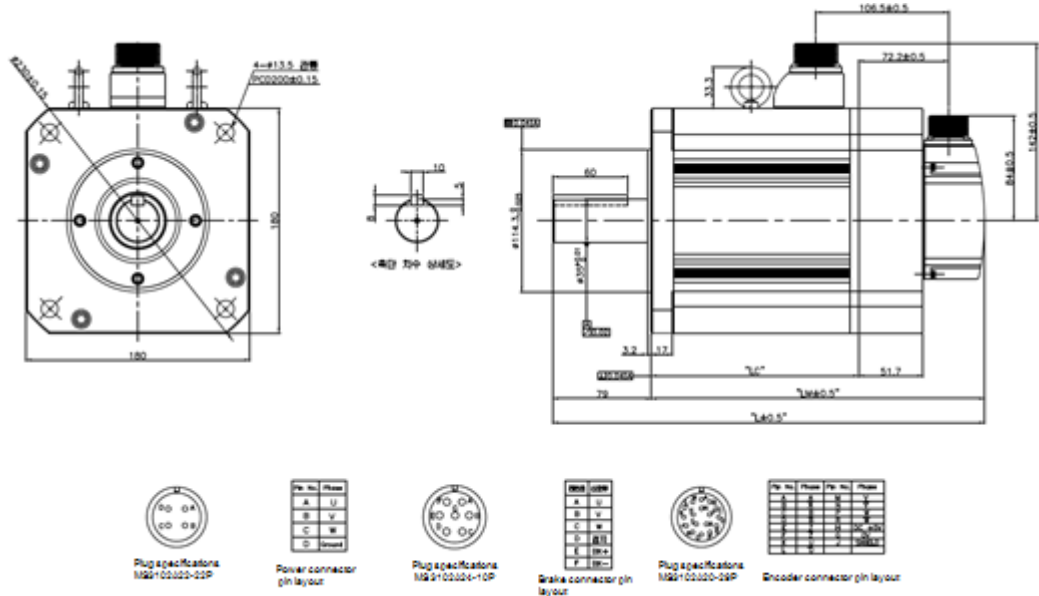

Name	External Dimensions			Weight (Kg)
	L	LM	LC	
SF30A, SF22D, SF20G, SF12M	261.5(312.9)	182.5(233.9)	133(132.7)	12.4(19.2)
SF50A, LF35D, LF30G, SF20M	295.5(346.9)	216.5(267.9)	167(166.7)	17.7(24.9)
SF55D, SF44G LF30M	345.5(396.9)	266.5(317.9)	217(216.7)	26.3(33.4)
SF44M	405.5(456.9)	326.5(377.9)	277(276.7)	35.6(42.8)

- Note 1)** SF30M or above models have eye bolts.
- Note 2)** Use DC power (24 V) to operate the brake.
- Note 3)** The sizes in parentheses apply when attached to the brakes.
- Note 4)** Option specification: Serial M-Turn Encoder PinMap

<Serial S-turn Encoder Connector>

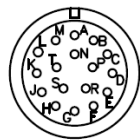

Pin No.	Phase	Pin No.	Phase
A	MA	M	--
B	MA	N	--
C	SL	P	--
D	SL	R	--
E	--	H	+5V
F	--	G	0V
K	--	J	SHIELD
L	--		

Plug : MS3102A20-29P

<Serial M-turn Encoder Connector>

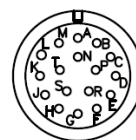

Pin No.	Phase	Pin No.	Phase
A	MA	M	--
B	MA	N	--
C	SL	P	--
D	SL	R	--
E	VOD_B	H	+5V
F	GND_B	G	0V
K	--	J	SHIELD
L	--		

Plug : MS3102A20-29P

## ■ SG Series | APM-SG22D, SG20G, SG12M, APM-LG35D, LG30G, SG20M, APM-SG55D, SG44G, LG30M, APM-SG44M

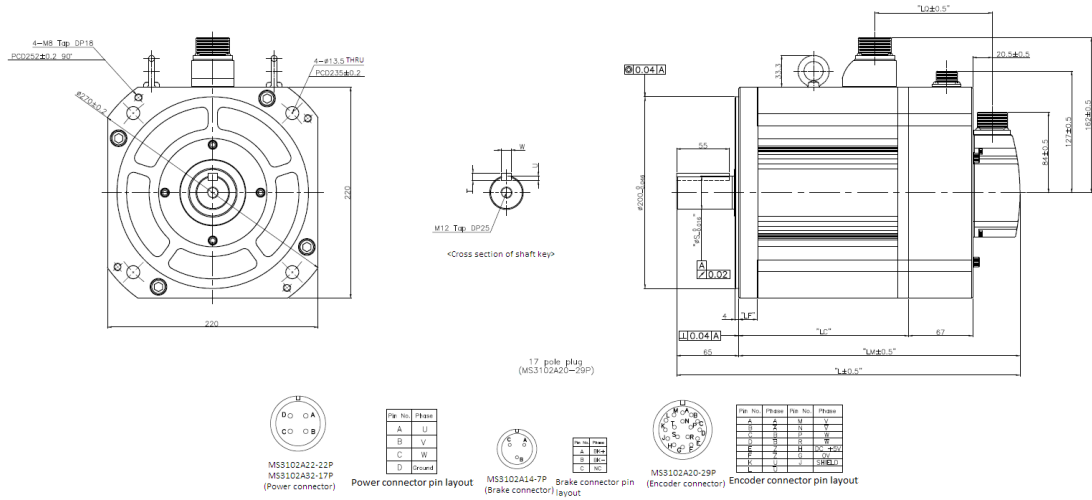

Name	External Dimensions			Weight (Kg)
	L	LM	LC	
SG22D, SG20G, SG12M	236.5(302.7)	171.5(237.7)	122(121.2)	16.95(30.76)
LG35D, LG30G, SG20M	256.5(322.7)	191.5(257.7)	142(142.2)	21.95(35.7)
SG55D, SG44G, LG30M	292.5(358.7)	227.5(293.7)	178(177.2)	30.8(44.94)
SG44M	320.5(386.7)	255.5(321.7)	206(205.2)	37.52(50.94)

- Note 1)** Use DC power (90 V) to operate the brake.
- Note 2)** The sizes in parentheses apply when attached to the brakes.
- Note 3)** Option specification: Serial M-Turn Encoder PinMap

### <Serial S-turn Encoder Connector>

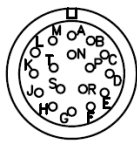

Pin No.	Phase	Pin No.	Phase
A	MA	M	-
B	MA	N	-
C	SL	P	-
D	SL	R	-
E	-	H	+5V
F	-	G	0V
K	-	J	SHIELD
L	-	-	-

Plug : MS3102A20-29P

### <Serial M-turn Encoder Connector>



Pin No.	Phase	Pin No.	Phase
A	MA	M	-
B	MA	N	-
C	SL	P	-
D	SL	R	-
E	VOD_B	H	+5V
F	GND_B	G	0V
K	-	J	SHIELD
L	-	-	-

Plug : MS3102A20-29P

■ **APM-HB01A (Hollow Shaft), APM-HB02A (Hollow Shaft), APM-HB04A (Hollow Shaft)**

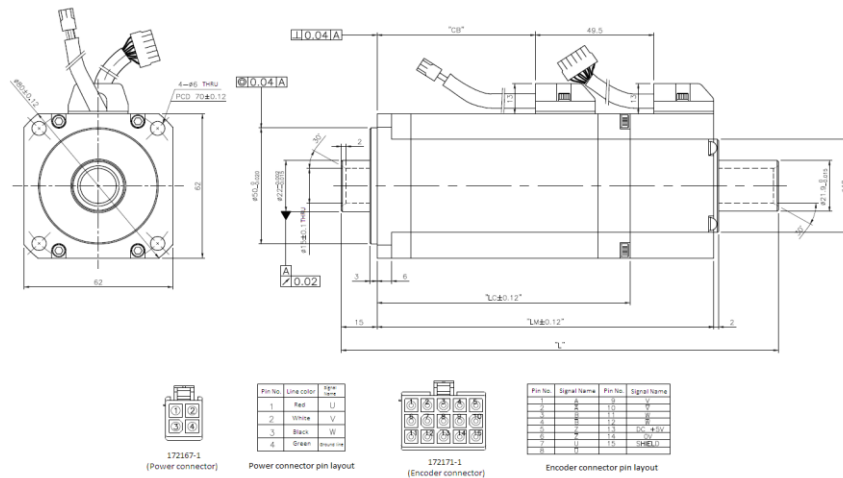

Name	External Dimensions				Hollow Shaft Diameter	Weight (kg)
	L	LM	LC	CB		
HB01A	140.5	98.5	68.5	24	15	0.89
HB02A	154.5	112.5	82.5	38	15	1.16
HB04A	182.5	140.5	105.5	66	15	1.69

■ **APM-HE09A (Hollow Shaft), APM-HE15A (Hollow Shaft)**

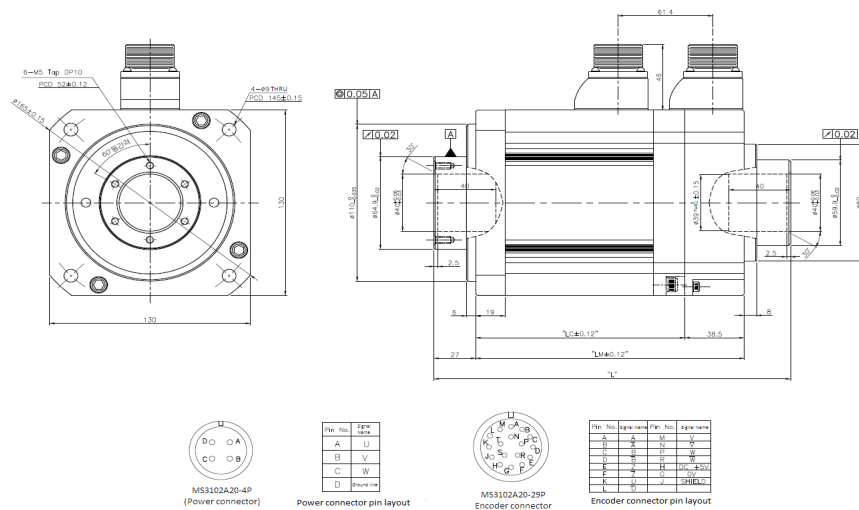

Name	External Dimensions			Hollow Shaft Diameter	Weight (kg)
	L	LM	LC		
HE09A	207	150	111.5	40	5.82
HE15A	231	174	135.5	40	7.43

■ **FB Series : APM-FB01A, APM-FB02A, APM-FB04A (For the drawing of Rear Type cable, it is available on request)**

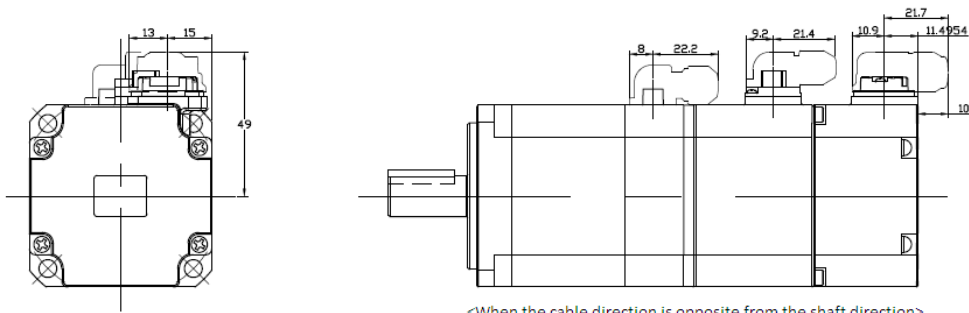
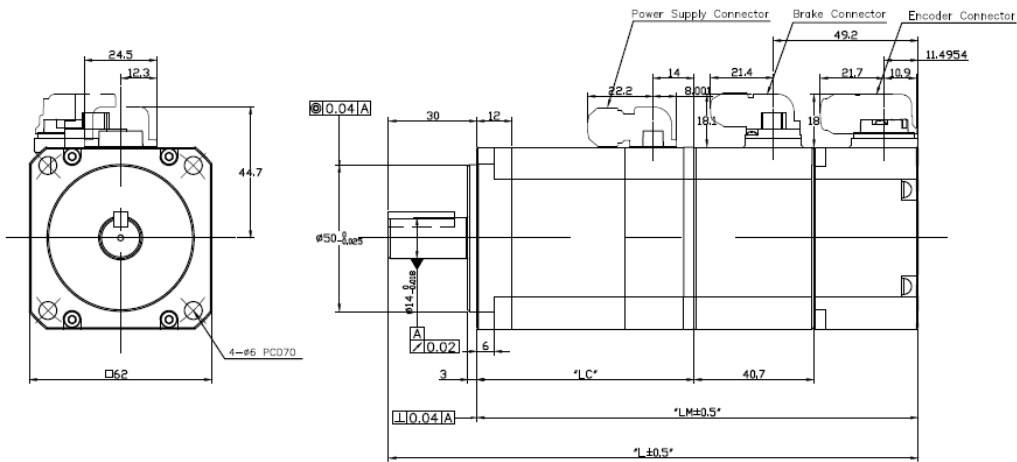
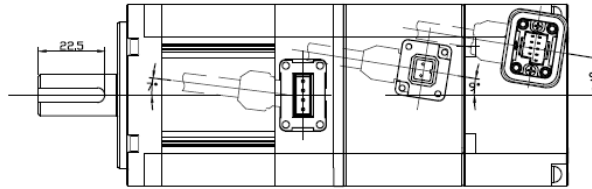
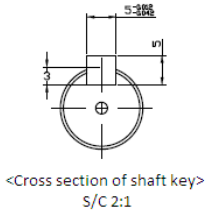

<When the cable direction is opposite from the shaft direction>

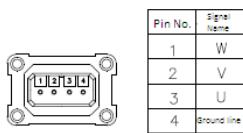

Power connector pin layout



Single Turn (N)		Multi Turn (M)	
Pin No.	Signal Name	Pin No.	Signal Name
1	MA	1	MA
2	SLO	2	SLO
3	-	3	GND_B
4	OV	4	OV
5	Shield	5	Shield
6	MA	6	MA
7	SLO	7	SLO
8	-	8	VDD_R
9	+5V	9	+5V

Encoder connector pin layout

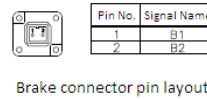

Brake connector pin layout

Name	External Dimensions			Weight(kg)
	L	LM	LC	
FB01A	109(149.2)	79(119.2)	43.5(43)	0.72(1.3)

FB02A	120(160.2)	90(130.2)	54.5(54)	0.94(1.49)
FB04A	140(150.2)	110(150.2)	74.5(74)	1.32(1.87)

**Note 1)** Use DC power (24V) to operate the brake.

**Note 2)** The sizes in parentheses apply when attached to the brakes.

**■ FC Series | APM-FC04A,FC03D, APM-FC06A,FC05D, APM-FC08A,FC06D, APM-FC10A,FC07D**

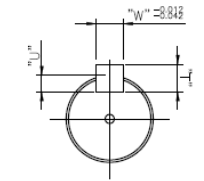

<Cross section of shaft key>  
S/C 2:1

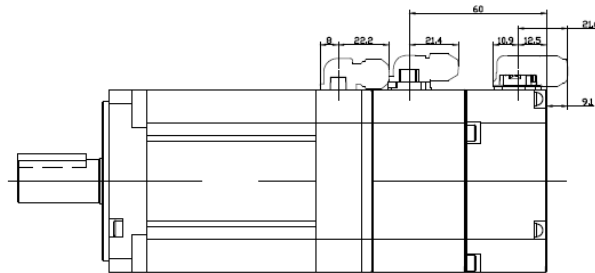
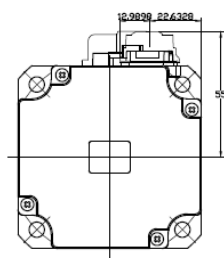
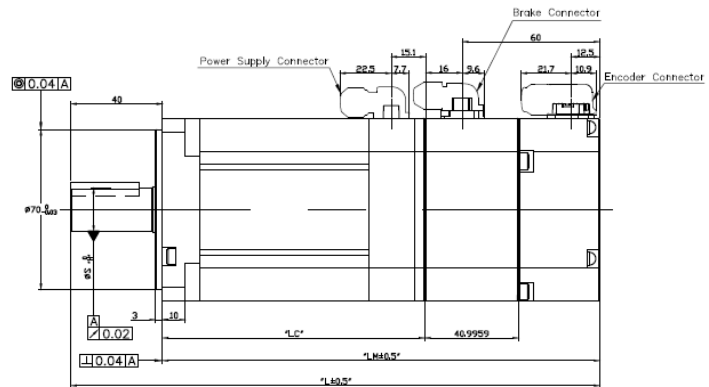
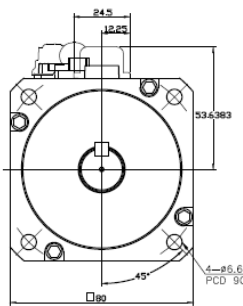
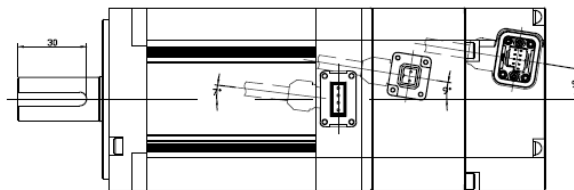

<When the cable direction is opposite from the shaft direction>

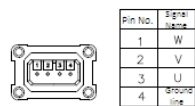

Power connector pin layout



Single Turn (N)		Multi Turn (M)	
Pin No.	Signal Name	Pin No.	Signal Name
1	NA	1	NA
2	REP	2	REP
3	+	3	24V(+)
4	0V	4	0V
5	SHIELD	5	SHIELD
6	NA	6	NA
7	REP	7	REP
8	+	8	24V(+)
9	0V	9	0V

Encoder connector pin layout

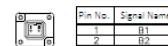

Brake connector pin layout

Name	External Dimensions			Key Dimensions					Weight(kg)
	L	LM	LC	S	H	T	W	U	
FC04A,FC03D	136.5(177)	96.5(137)	61(60.5)	14	-0.018	5	5	3	1.56(2.6)

FC06A,FC05D	154.5(195)	114.5(155)	79(78.5)	19	-0.021	6	6	3.5	2.18(3.22)
FC08A,FC06D	172.5(213)	132.5(173)	97(96.5)	19	-0.021	6	6	3.5	2.72(3.76)
FC10A,FC07D	190.5(231)	150.5(191)	115(114.5)	19	-0.021	6	6	3.5	3.30(4.34)

**Note 1)** Use DC power (24V) to operate the brake.

**Note 2)** The sizes in parentheses apply when attached to the brakes.

**■ FE Series | APM-FE09A, FE06D, FE05G, FE03M, APM-FE15A, FE11D, FE09G, FE06M, APM-FE22A, FE16D, FE13G, FE09M, APM-FE30A, FE22D, FE17G, FE12M**

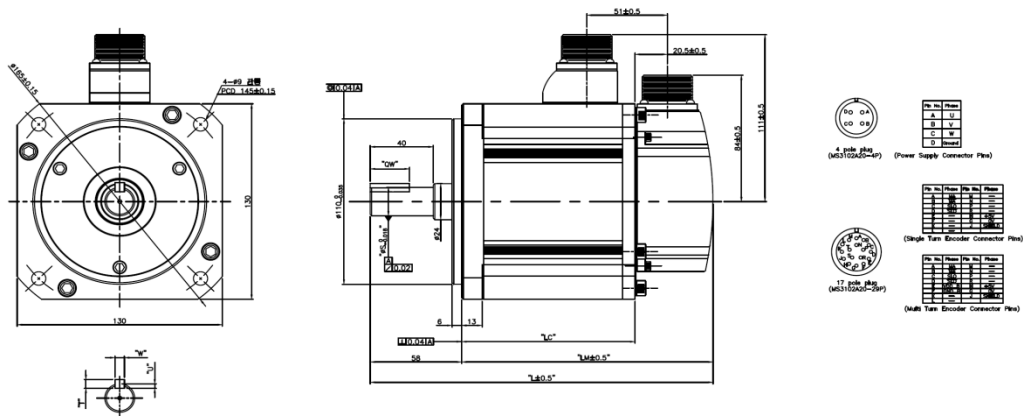

**<Standard>**

Name	External Dimensions				Key Dimensions				Weight(kg)
	L	LM	LC	S	QW	T	W	U	
FE09A,FE06D,FE05G,FE03M	197.3	139.3	89.8	19	25	5	5	3	5.04
FE15A,FE11D,FE09G,FE06M	217.3	159.3	109.8	19	25	5	5	3	6.74
FE22A,FE16D,FE13G,FE09M	237.3	179.3	129.8	22	25	6	6	3.5	8.48
FE30A,FE22D,FE17G,FE12M	255.3	197.3	147.8	24	36	7	8	4	10.05

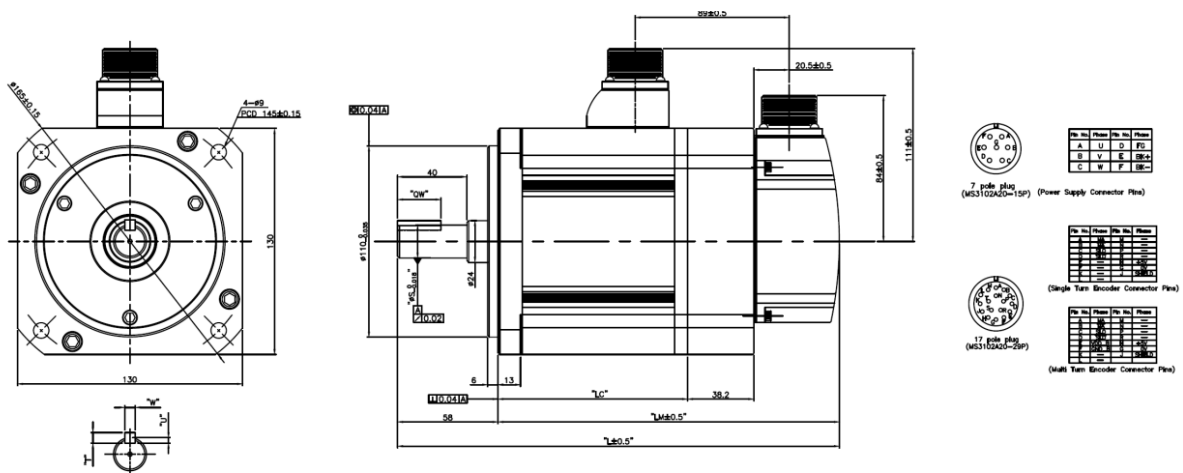

**<Brake>**



Name	External Dimensions				Key Dimensions				Weight(kg)
	L	LM	LC	S	QW	T	W	U	
FE09A,FE06D,FE05G,FE03M	235.3	177.3	89.6	19	25	5	5	3	6.58
FE15A,FE11D,FE09G,FE06M	255.3	197.3	109.6	19	25	5	5	3	8.28
FE22A,FE16D,FE13G,FE09M	275.3	217.3	129.6	22	25	6	6	3.5	10.02
FE30A,FE22D,FE17G,FE12M	294	236	148	24	36	7	8	4	11.59

**Note 1)** Use DC power (24V) to operate the brake.

**■ FF Series | APM-FF30A, FF22D, FF20G, FF12M, APM-FF50A, FF35D, FF30G, FF20M, APM-FF30M, FF55D, FF44G, APM-FF44M**

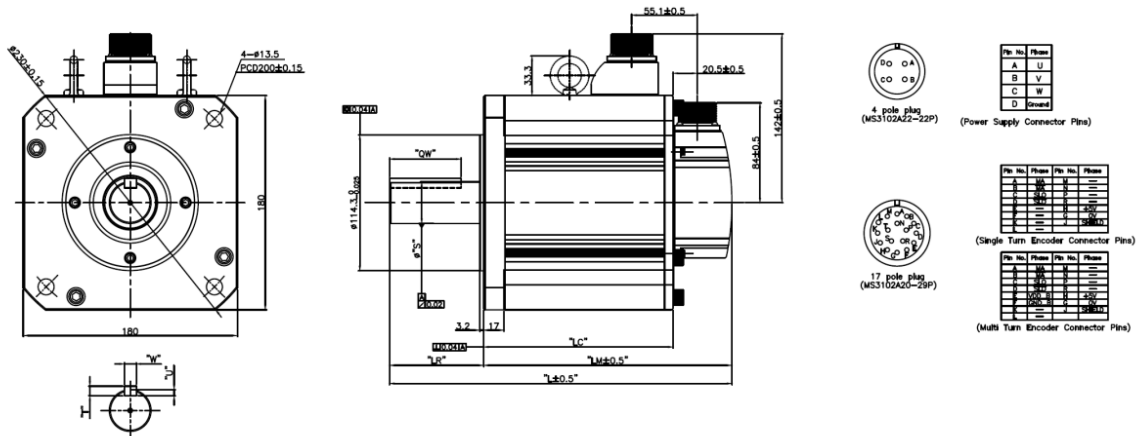

<Standard>

Name	External Dimensions				Key Dimensions					Weight(kg)
	L	LM	LC	LR	S	QK	T	W	U	
FF30A,22D,20G,12M	257.5	178.5	129	79	35	60	8	10	5	12.5
FF50A,35D,30G,20M	287.5	208.5	159							17.4
44G,30M	331.5	252.5	203							25.2
44M	384.5	305.5	256							33.8

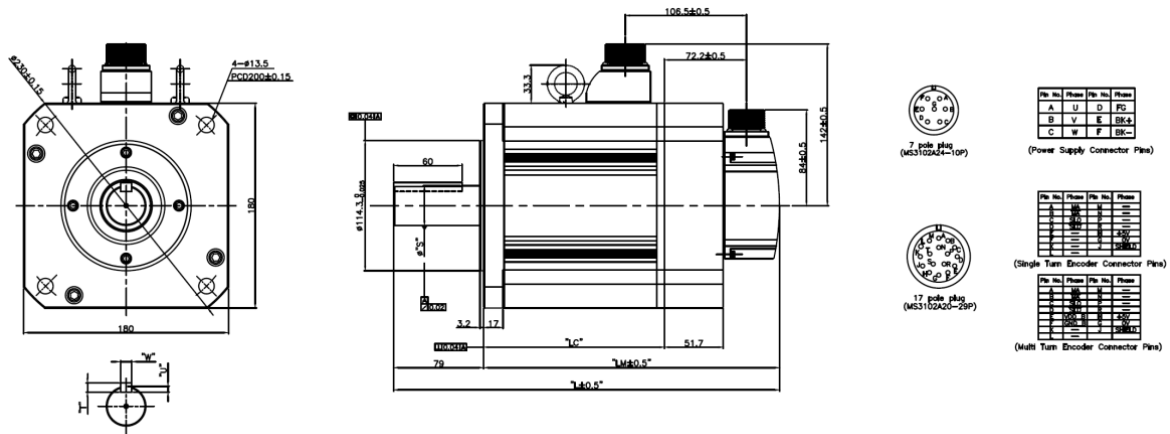

<Brake>

Name	External Dimensions				Key Dimensions			Weight(kg)
	L	LM	LC	S	T	W	U	
FF30A,22D,20G,12M	308.9	229.9	128.7	35	8	10	5	19.7
FF50A,35D,30G,20M	338.9	259.9	158.7					24.6
44G,30M	382.9	303.9	202.7					32.4
44M	435.9	356.9	234.7	42	8	12	5	41.0

Note 1) FF30M or above models have eye bolts.

Note 2) Use DC power (24V) to operate the brake.

■ **FG Series | APM-FG22D, FG20G, FG12M, APM-FG35D, FG30G, FG20M, APM-FG55D, FG44G, FG30M, APM-FG44M**

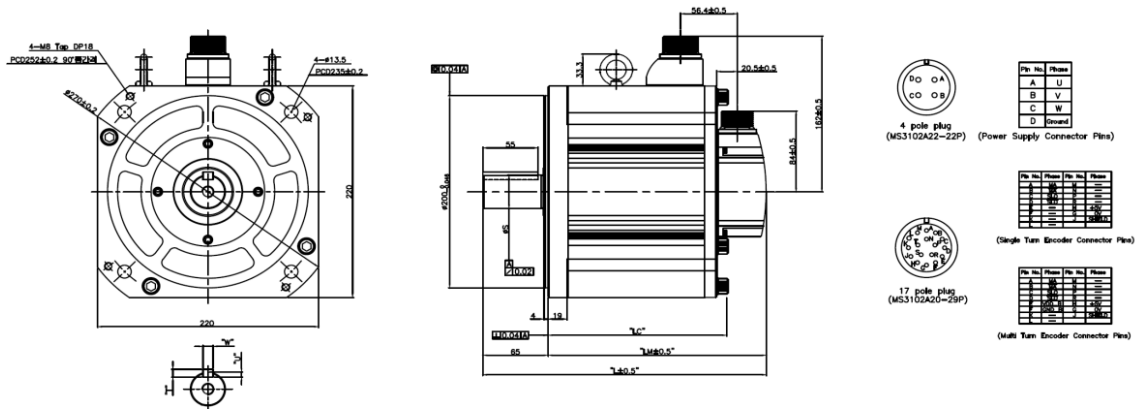

<Standard>

Name	External Dimensions				Key Dimensions			Weight(kg)
	L	LM	LC	S	T	W	U	
FG22D,FG20G,FG12M	229.5	164.5	115	35	8	10	5	15.42
FG35D,FG30G,FG20M	250.5	185.5	135					20.22
FG44G,FG30M	282.5	217.5	168					28.02
FG44M	304.5	239.5	190	42	8	12	5	33.45

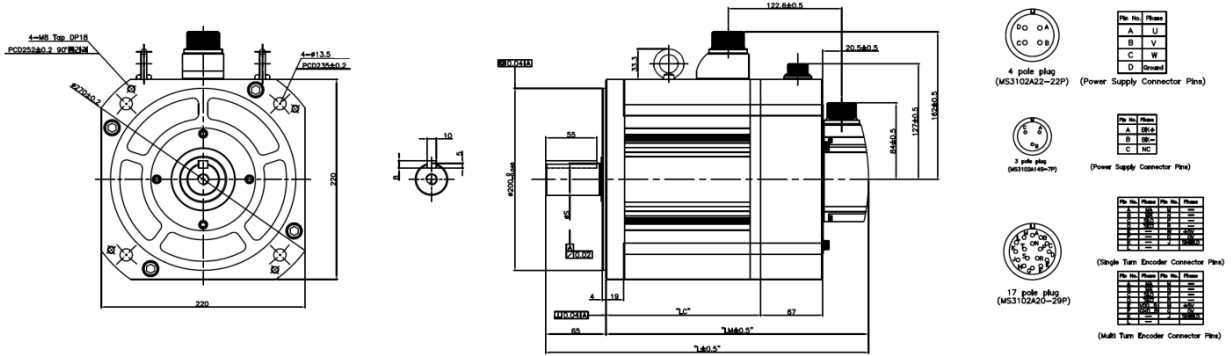

<Brake>

Name	External Dimensions				Key Dimensions			Weight(kg)
	L	LM	LC	S	T	W	U	
FG22D,FG20G,FG12M	295.7	230.7	114.2	35	8	10	5	29.23
FG35D,FG30G,FG20M	316.7	251.7	135.2					34.03
FG44G,FG30M	348.7	283.7	167.2					41.83
FG44M	370.7	305.7	189.2	42	8	12	5	47.26

Note 1) Use DC power (90V) to operate the brake.

■ FAL Series | APM-FALRA, FAL01A, FAL015A

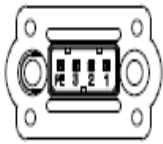
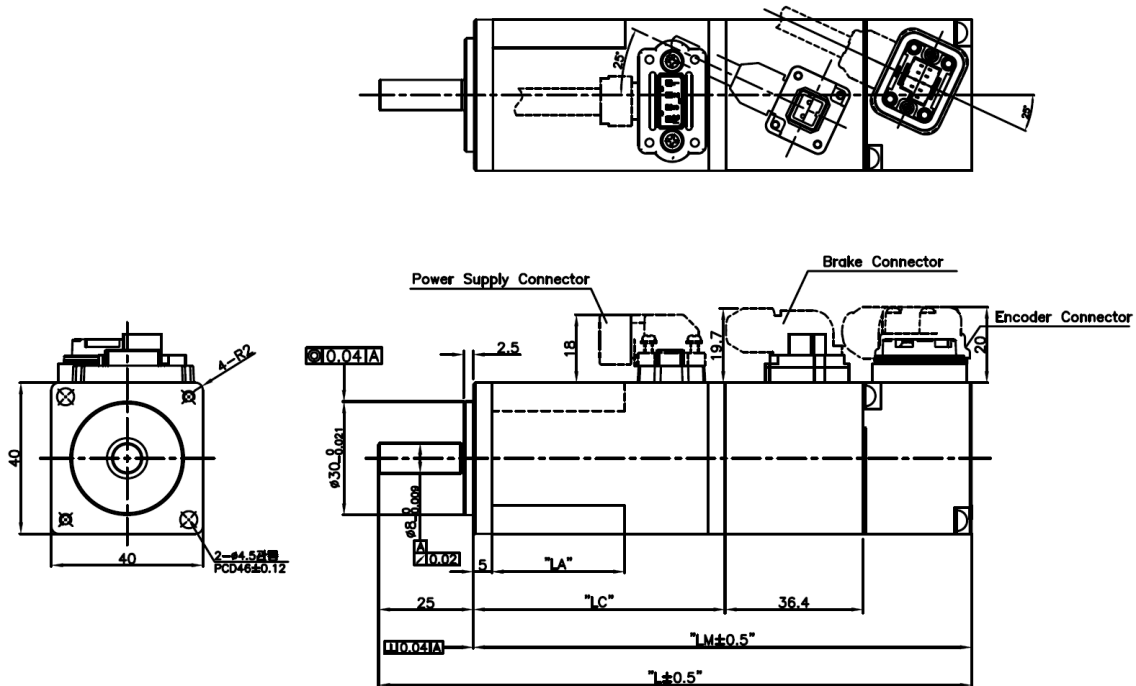

Pin No.	Signal name
1	U
2	V
3	W
PE	FG

<SM-JNB-04R/Suntone> <Power connector pin array>



Multi Turn (M)		Multi Turn (M)	
Pin No.	Signal name	Pin No.	Signal name
1	MA	6	MA
2	SLO	7	SLO
3	GND_B	8	VDD_B
4	0V	9	+5V
5	Shield		

<BASE ASSY : 2108418-1(Tyco)  
HSG : 2108422-1(Tyco)  
CONTACT : 2069391-2(Tyco)>

<Encoder connector pin array>

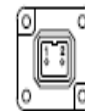

Pin No.	Signal name
1	B1
2	B2

<JMAT02PJM-R/Tyco> <Brake connector pin array>

Name	External Dimensions				Weight (kg)
	L	LM	LC	LA	
FALR5A	103.2(139.6)	78.2(114.6)	49.5	23	0.31(0.66)
FAL01A	120.2(156.6)	95.2(131.6)	66.5	35	0.45(0.80)
FAL015A	140.2	115.2	86.5	35	0.61

- NOTE 1) Use DC power (24V) to operate the brake.
- NOTE 2) The dimension of ( ) is for brake type motor.
- NOTE 3) To connect FAL motor, connect power cable first.

■ FBL Series | APM-FBL01A, FBL02A, FBL04A

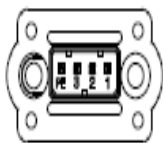
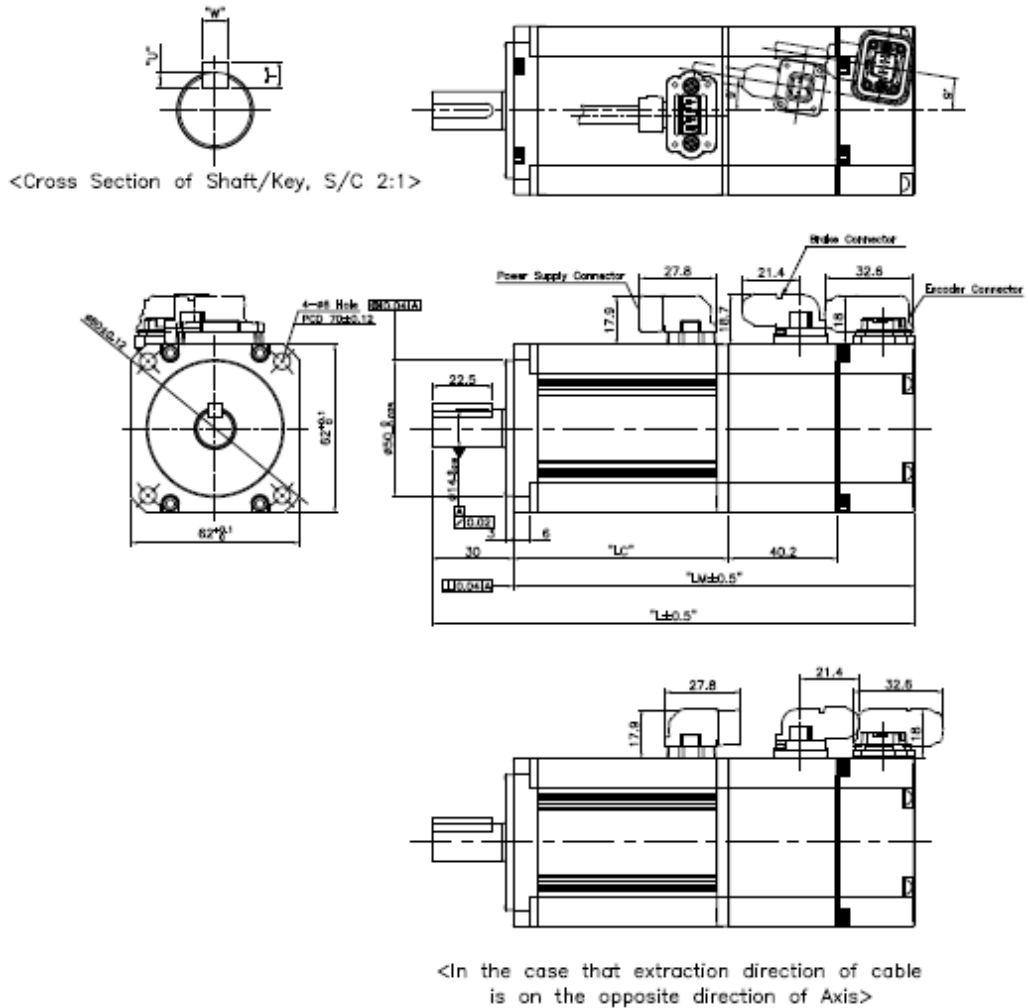

Pin No.	Signal Name
1	U
2	V
3	W
PE	FG

<SM-INB-04R/Suntone> <Power connector pin array>



Multi Turn (M)		Multi Turn (M)	
Pin No.	Signal name	Pin No.	Signal name
1	MA	6	MA
2	SLO	7	SLO
3	GND_B	8	VDD_B
4	OV	9	+5V
5	Shield		

<Encoder connector pin array>

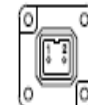

Pin No.	Signal name
1	B1
2	B2

<JMA4T02PJM-R/Tyco> <Brake connector pin array>

<BASE ASSY : 2108418-1(Tyco)  
HSG : 2108422-1(Tyco)  
CONTACT : 2069391-2(Tyco)>

Name	External Dimensions					Key Dimensions			Weight (kg)
	L	LM	LC	S	H	T	W	U	

FBL01A	107.2(147.2)	77.2(117.2)	48.5(48.3)	14	-0.018	5	5	3	0.56(1.3)
FBL02A	118.2(158.2)	88.2(128.2)	59.5(59.3)	14	-0.018	5	5	3	0.74(1.48)
FBL04A	138.2(178.2)	108.2(148.2)	79.5(79.3)	14	-0.018	5	5	3	1.06(1.8)

NOTE 1) Use DC power (24V) to operate the brake.

NOTE 2) The dimension of ( ) is for brake type motor.

**■ FCL Series | APM-FCL04A, FCL03D, FCL06A, FCL05D, FCL08A, FCL06D, FCL10A, FCL07D**

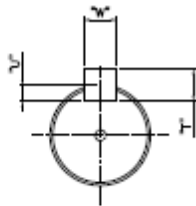

<Cross Section of Shaft/Key, S/C 2:1>

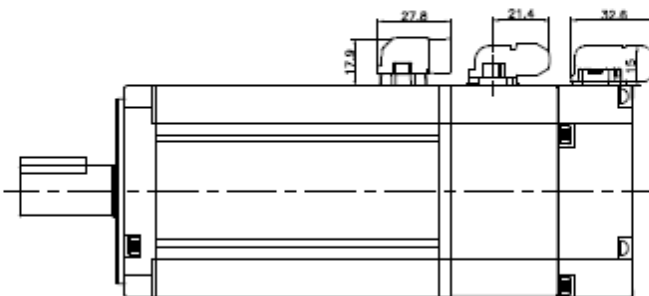
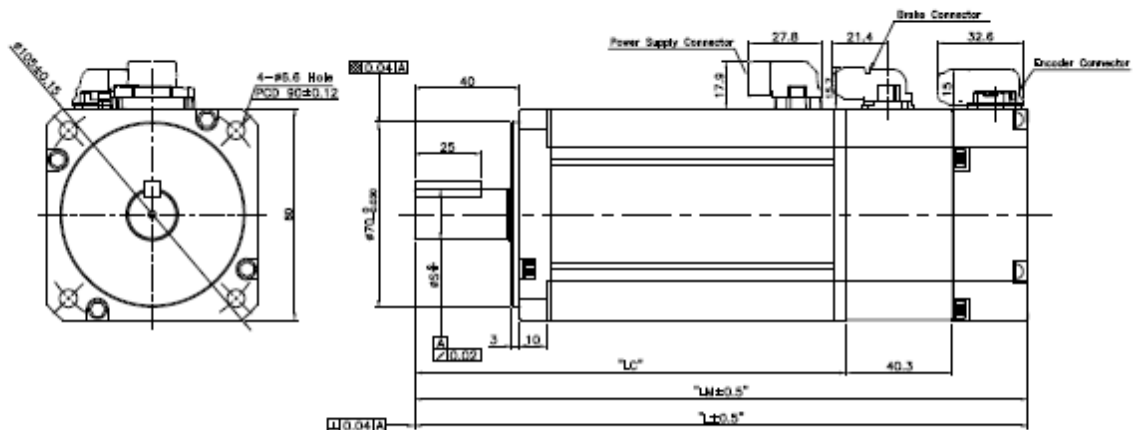
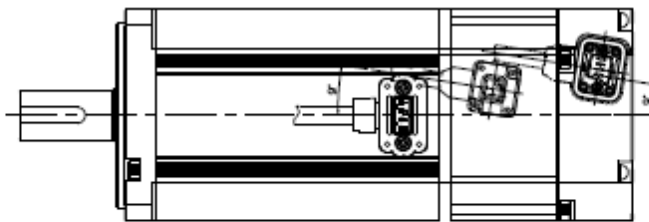

<In the case that extraction direction of cable is on the opposite direction of Axis>

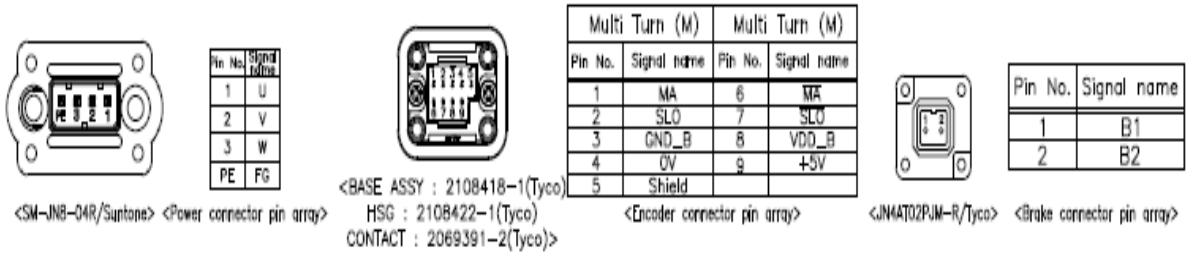

Name	External Dimensions					Key Dimensions			Weight(kg)
	L	LM	LC	S	H	T	W	U	
FCL04A,FCL03D	138.7(179.5)	98.7(139.5)	70(69.8)	14	-0.018	5	5	3	1.52(2.32)/1.26(2.06)
FCL06A,FCL05D	156.7(197.5)	116.7(157.5)	88(87.8)	19	-0.021	6	6	3.5	2.14(2.94)/2.12(2.92)
FCL08A,FCL06D	174.7(215.5)	134.7(175.5)	106(105.8)	19	-0.021	6	6	3.5	2.68(3.48)/2.66(3.46)
FCL10A,FCL07D	192.7(233.5)	152.7(193.5)	124(123.8)	19	-0.021	6	6	3.5	3.30(4.10)/2.78(3.58)

NOTE 1) Use DC power (24V) to operate the brake.

NOTE 2) The dimension of ( ) is for brake type motor.

## 10.2 The Servo Drive

### 10.2.1 Product Features

Item		Name	L7NA 001B	L7NA 002B	L7NA 004B	L7NA 008B	L7NA 010B	L7NA 020B	L7NA 035B	L7NA 050B
Input power	Main power	3-phase AC 200-230 V (-15-10[%]), 50-60 [Hz]								
	Control power	Single-phase AC 200-230 V (-15-10[%]), 50-60 [Hz]								
Rated current (A)		1.4	1.7	3.0	5.2	6.75	13.5	16.7	32	
Peak current (A)		4.2	5.1	9.0	15.6	20.25	40.5	50.1	96	
Encoder Type		Serial 17 bit/19 bit/21 bit								
Control performance	Speed control range	Maximum 1: 5000								
	Frequency response	Maximum 1 kHz or more (when the 19-bit serial encoder is applied)								
	Speed change rate	±0.01% or lower (when the load changes between 0 and 100%) ±0.1% or less (temperature of 25 °C (±10))								
	Torque control repetition accuracy	Within ±1%								
Supported drive modes (CiA402)		Profile Position Mode Profile Velocity Mode Profile Torque Mode Interpolated Position Mode Cyclic Synchronous Position Mode Cyclic Synchronous Velocity Mode Cyclic Synchronous Torque Mode Homing Mode								
Digital input/output	Digital input	Total 6 input channels (allocable) PCON, GAIN2, ALMRST, HOME, P-OT, N-OT Above 6 functions can be used selectively for assignment. Signal can be set as positive logic or negative logic.								
	Touch probe input	There are 2 input channels. Provides rising and falling edge detection functions for each channel.								
	Digital output	Total 4 channels (allocable) ALARM, READY, ZSPD, BRAKE, INPOS, INSPD, WARN Above 7 outputs can be used selectively for assignment. Signal can be set as positive logic or negative logic.								
Additional communication	USB	Program download is available with USB Communication.								



Item		Name	L7NA	L7NA	L7NA	L7NA	L7NA	L7NA	L7NA	
			001B	002B	004B	008B	010B	020B	035B	050B
Built-in functions	Dynamic braking	Standard built-in brake (activated when the servo alarm goes off or when the servo is off).								
	Regenerative braking	Both the default built-in brake and an externally installed brake are possible.								
	Display function	Seven segments (5 DIGIT)								
	Self-setting function	The [Mode] key changes the content displayed in the 7 segments.								
	Additional function	Auto gain tuning function								
	Protection function	Overcurrent, overload, overvoltage, low voltage, main power input error, control power input error, overspeed, motor cable, heating error (power module heating, drive temperature error), encoder error, excessive regeneration, sensor error, communication error								
Environment	Temperature	0 ~ 50[°C]								
	Humidity	90% RH or less (no condensation)								
	Environment	Indoors in an area free from corrosive or combustible gases, liquids, or dust.								

## 10.3 Outline Diagram

### ■ L7NA001B - L7NA004B

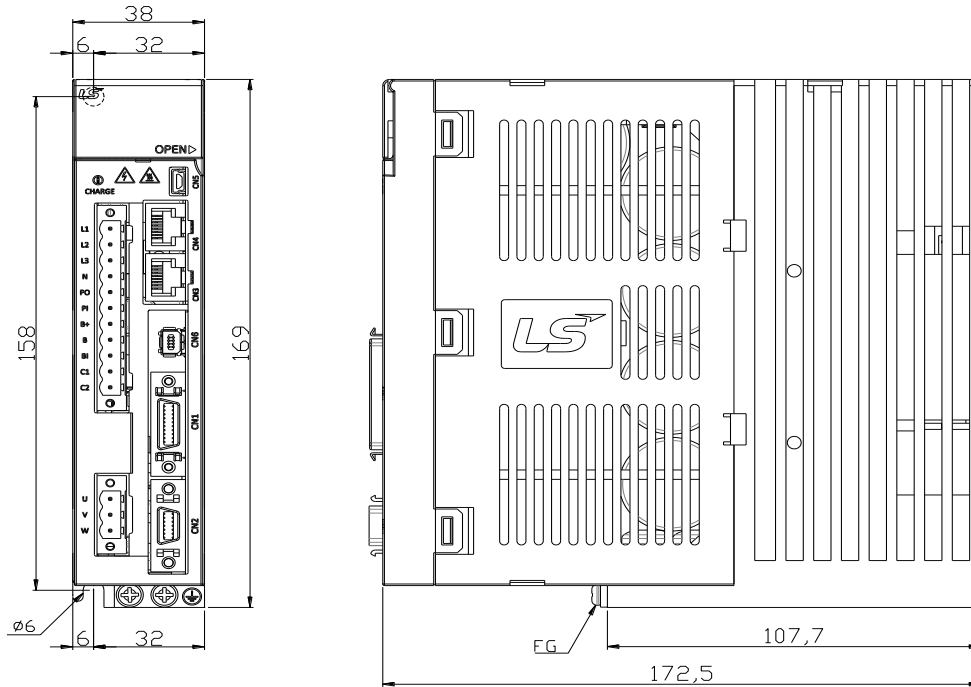

★ Weight: 1kg

### ■ L7NA008B ~ L7NA010B

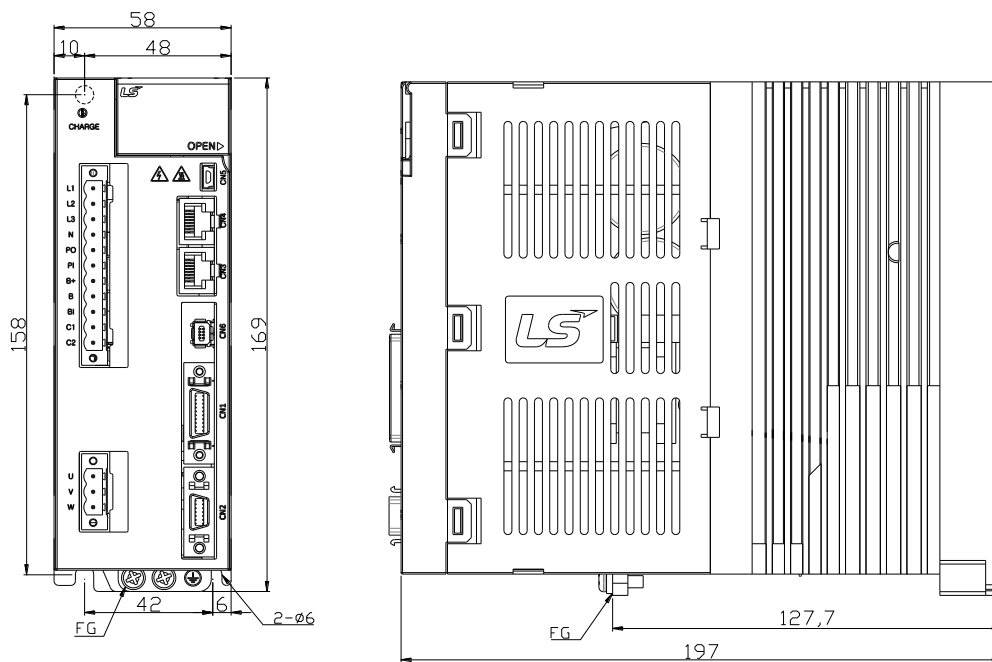

★ Weight: 1.5 kg (including the cooling fan)

■ L7NA020B ~ L7NA035B

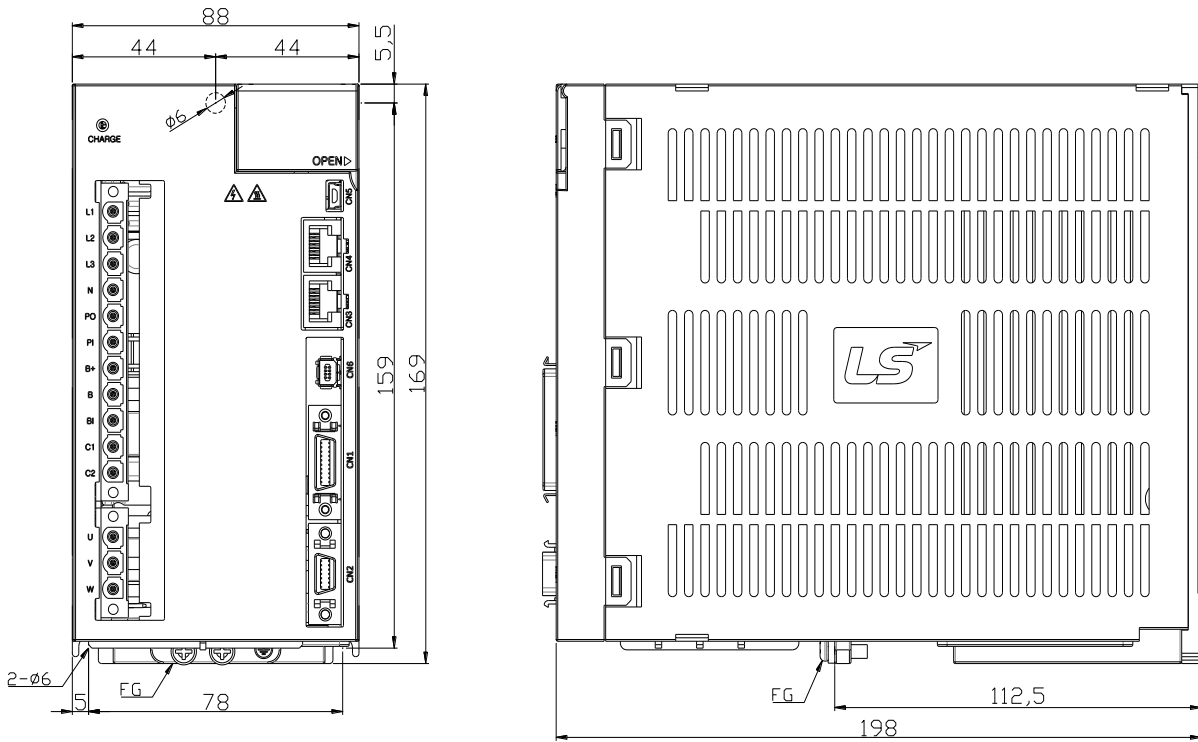

★ Weight: 2.5 kg (including the cooling fan)

■ L7NA050B

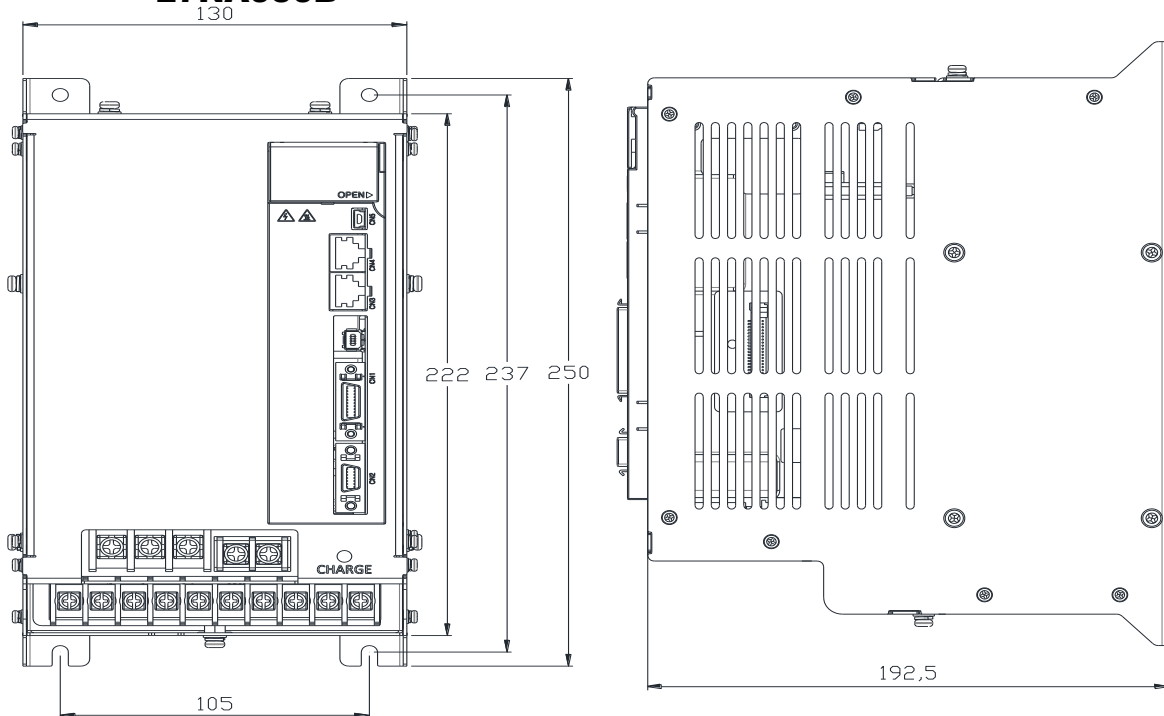

★ Weight: 5.5 kg (including the cooling fan)

# 10.4 Options and Peripheral Devices

## ■Option (serial encoder cable)

Category	Product Name	Name (Note 1)	Applicable Motors	Specifications																																																																	
For signaling	Serial type encoder cable (Small capacity)	APCS-E□□□CS	All models of APM-SA, (Coming) APM-SB, and APM-SC Series	<p>Motor connection: AMP 172161-1 CAP</p> <table border="1"> <tr><th>Pin No.</th><th>Encoder Signal</th></tr> <tr><td>1</td><td>MA</td></tr> <tr><td>2</td><td>MA</td></tr> <tr><td>3</td><td>SLO</td></tr> <tr><td>4</td><td>SLO</td></tr> <tr><td>5</td><td>-</td></tr> <tr><td>6</td><td>-</td></tr> <tr><td>7</td><td>+5V</td></tr> <tr><td>8</td><td>0V</td></tr> <tr><td>9</td><td>SHIELD</td></tr> </table> <p>Drive connection (CN2)</p> <table border="1"> <tr><th>Pin No.</th><th>Encoder Signal</th><th>Pin No.</th><th>Encoder Signal</th></tr> <tr><td>1</td><td>-</td><td>8</td><td>-</td></tr> <tr><td>2</td><td>-</td><td>9</td><td>-</td></tr> <tr><td>3</td><td>MA</td><td>10</td><td>-</td></tr> <tr><td>4</td><td>MA</td><td>11</td><td>-</td></tr> <tr><td>5</td><td>SLO</td><td>12</td><td>-</td></tr> <tr><td>6</td><td>SLO</td><td>13</td><td>-</td></tr> <tr><td>7</td><td>0V</td><td>14</td><td>+5V</td></tr> <tr><td>Plate</td><td></td><td>SHIELD</td><td></td></tr> </table> <p>&lt;Motor Connection&gt; &lt;Driver Connection&gt;</p> <ol style="list-style-type: none"> <li>Motor connection                     <ol style="list-style-type: none"> <li>Cap specifications (9 positions): 172161-1 (AMP)</li> <li>Socket specifications: 170361-1 (AMP)</li> </ol> </li> <li>Drive connection (CN2)                     <ol style="list-style-type: none"> <li>Case specifications: 10314-52A0-008 (3M)</li> <li>Connector specifications: 10114-3000VE (3M)</li> </ol> </li> <li>Cable specifications: 3Px0.2SQ or 3Px24AWG</li> </ol>	Pin No.	Encoder Signal	1	MA	2	MA	3	SLO	4	SLO	5	-	6	-	7	+5V	8	0V	9	SHIELD	Pin No.	Encoder Signal	Pin No.	Encoder Signal	1	-	8	-	2	-	9	-	3	MA	10	-	4	MA	11	-	5	SLO	12	-	6	SLO	13	-	7	0V	14	+5V	Plate		SHIELD										
Pin No.	Encoder Signal																																																																				
1	MA																																																																				
2	MA																																																																				
3	SLO																																																																				
4	SLO																																																																				
5	-																																																																				
6	-																																																																				
7	+5V																																																																				
8	0V																																																																				
9	SHIELD																																																																				
Pin No.	Encoder Signal	Pin No.	Encoder Signal																																																																		
1	-	8	-																																																																		
2	-	9	-																																																																		
3	MA	10	-																																																																		
4	MA	11	-																																																																		
5	SLO	12	-																																																																		
6	SLO	13	-																																																																		
7	0V	14	+5V																																																																		
Plate		SHIELD																																																																			
For signaling	Multiturn type encoder cable (Small capacity)	APCS-E□□□CS1	All models of APM-SA, (Coming) APM-SB, and APM-SC Series	<p>Motor connection: AMP 172161-1 CAP</p> <table border="1"> <tr><th>Pin No.</th><th>Encoder Signal</th></tr> <tr><td>1</td><td>MA</td></tr> <tr><td>2</td><td>MA</td></tr> <tr><td>3</td><td>SL</td></tr> <tr><td>4</td><td>SL</td></tr> <tr><td>5</td><td>VDD_B</td></tr> <tr><td>6</td><td>GND_B</td></tr> <tr><td>7</td><td>+5V</td></tr> <tr><td>8</td><td>0V</td></tr> <tr><td>9</td><td>SHIELD</td></tr> </table> <p>Drive connection (CN2)</p> <table border="1"> <tr><th>Pin No.</th><th>Encoder Signal</th><th>Pin No.</th><th>Encoder Signal</th></tr> <tr><td>1</td><td>-</td><td>8</td><td>-</td></tr> <tr><td>2</td><td>-</td><td>9</td><td>-</td></tr> <tr><td>3</td><td>MA</td><td>10</td><td>-</td></tr> <tr><td>4</td><td>MA</td><td>11</td><td>-</td></tr> <tr><td>5</td><td>SL</td><td>12</td><td>-</td></tr> <tr><td>6</td><td>SL</td><td>13</td><td>-</td></tr> <tr><td>7</td><td>0V</td><td>14</td><td>+5V</td></tr> <tr><td>Plate</td><td></td><td>SHILDE</td><td></td></tr> </table> <p>Battery connection</p> <table border="1"> <tr><th>Pin No.</th><th>Encoder Signal</th><th>Signal</th></tr> <tr><td>1</td><td>BATTERY</td><td>BLK</td></tr> <tr><td>2</td><td>BATTERY</td><td>EV</td></tr> </table> <p>&lt;Motor connection&gt; &lt;Drive connection&gt; &lt;Battery connection&gt;</p> <ol style="list-style-type: none"> <li>Motor connection                     <ol style="list-style-type: none"> <li>Cap specifications (9 positions): 172161-1 (AMP)</li> <li>Socket specifications: 170361-1 (AMP)</li> </ol> </li> <li>Drive connection (CN2)                     <ol style="list-style-type: none"> <li>Case specifications: 10314-52A0-008 (3M) or SM-14J(Suntone)</li> <li>Connector specifications: 10114-3000VE (3M) or SM-14J(Suntone)</li> </ol> </li> <li>Cable specifications: 4Px0.2SQ or 4Px24AWG</li> </ol>	Pin No.	Encoder Signal	1	MA	2	MA	3	SL	4	SL	5	VDD_B	6	GND_B	7	+5V	8	0V	9	SHIELD	Pin No.	Encoder Signal	Pin No.	Encoder Signal	1	-	8	-	2	-	9	-	3	MA	10	-	4	MA	11	-	5	SL	12	-	6	SL	13	-	7	0V	14	+5V	Plate		SHILDE		Pin No.	Encoder Signal	Signal	1	BATTERY	BLK	2	BATTERY	EV
Pin No.	Encoder Signal																																																																				
1	MA																																																																				
2	MA																																																																				
3	SL																																																																				
4	SL																																																																				
5	VDD_B																																																																				
6	GND_B																																																																				
7	+5V																																																																				
8	0V																																																																				
9	SHIELD																																																																				
Pin No.	Encoder Signal	Pin No.	Encoder Signal																																																																		
1	-	8	-																																																																		
2	-	9	-																																																																		
3	MA	10	-																																																																		
4	MA	11	-																																																																		
5	SL	12	-																																																																		
6	SL	13	-																																																																		
7	0V	14	+5V																																																																		
Plate		SHILDE																																																																			
Pin No.	Encoder Signal	Signal																																																																			
1	BATTERY	BLK																																																																			
2	BATTERY	EV																																																																			

**Note 1)** The □□□ in the name indicates the type and length of each cable. Refer to the following table for this information

Cable length (m)	3	5	10	20
Robot cable	F03	F05	F10	F20
Regular cable	N03	N05	N10	N20

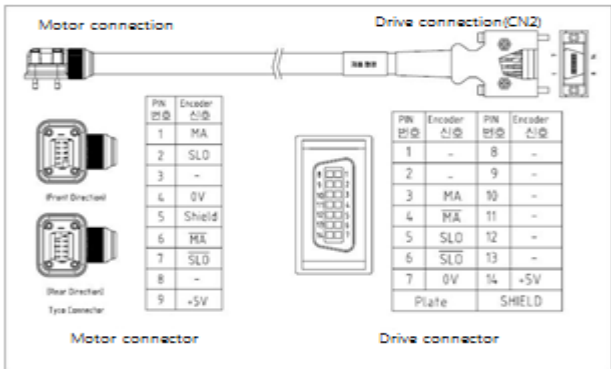
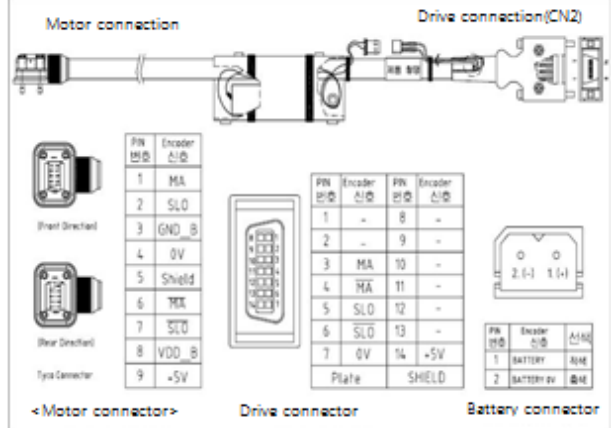
Category	Product Name	Name (Note 1)	Applicable Motors	Specifications																																																																	
For signaling	Flat motor type encoder cable (small capacity)	<p>APCS-E□□□ES-□</p> <p>*Front : APCS-E□□□ES (Load direction)</p> <p>* Rear : APCS-E□□□ES-R (Rear direction)</p>	All models of APM-FB APM-FC Series	 <p><b>Motor connector</b></p> <table border="1"> <thead> <tr> <th>핀 번호</th> <th>Encoder 신호</th> </tr> </thead> <tbody> <tr><td>1</td><td>MA</td></tr> <tr><td>2</td><td>SLO</td></tr> <tr><td>3</td><td>-</td></tr> <tr><td>4</td><td>0V</td></tr> <tr><td>5</td><td>Shield</td></tr> <tr><td>6</td><td>HA</td></tr> <tr><td>7</td><td>SLO</td></tr> <tr><td>8</td><td>-</td></tr> <tr><td>9</td><td>+5V</td></tr> </tbody> </table> <p><b>Drive connector (CN2)</b></p> <table border="1"> <thead> <tr> <th>핀 번호</th> <th>Encoder 신호</th> <th>핀 번호</th> <th>Encoder 신호</th> </tr> </thead> <tbody> <tr><td>1</td><td>-</td><td>8</td><td>-</td></tr> <tr><td>2</td><td>-</td><td>9</td><td>-</td></tr> <tr><td>3</td><td>MA</td><td>10</td><td>-</td></tr> <tr><td>4</td><td>HA</td><td>11</td><td>-</td></tr> <tr><td>5</td><td>SLO</td><td>12</td><td>-</td></tr> <tr><td>6</td><td>SLO</td><td>13</td><td>-</td></tr> <tr><td>7</td><td>0V</td><td>14</td><td>+5V</td></tr> <tr><td></td><td></td><td></td><td>SHIELD</td></tr> </tbody> </table> <ol style="list-style-type: none"> <li>Motor connection <ul style="list-style-type: none"> <li>a. Cap specifications: 2201825-1(Tyco)</li> <li>b. Socket specifications : 2174065-4(Tyco )</li> </ul> </li> <li>Drive connection (CN2) <ul style="list-style-type: none"> <li>a. Case specifications: 10314-52A0-008(3M) or SM-14J(Suntone)</li> <li>b. Connector specifications:10114-3000VE(3M) or SM-14J(Suntone)</li> </ul> </li> <li>Cable specifications: 3Px0.2SQ or 3Px24AWG</li> </ol>	핀 번호	Encoder 신호	1	MA	2	SLO	3	-	4	0V	5	Shield	6	HA	7	SLO	8	-	9	+5V	핀 번호	Encoder 신호	핀 번호	Encoder 신호	1	-	8	-	2	-	9	-	3	MA	10	-	4	HA	11	-	5	SLO	12	-	6	SLO	13	-	7	0V	14	+5V				SHIELD									
핀 번호	Encoder 신호																																																																				
1	MA																																																																				
2	SLO																																																																				
3	-																																																																				
4	0V																																																																				
5	Shield																																																																				
6	HA																																																																				
7	SLO																																																																				
8	-																																																																				
9	+5V																																																																				
핀 번호	Encoder 신호	핀 번호	Encoder 신호																																																																		
1	-	8	-																																																																		
2	-	9	-																																																																		
3	MA	10	-																																																																		
4	HA	11	-																																																																		
5	SLO	12	-																																																																		
6	SLO	13	-																																																																		
7	0V	14	+5V																																																																		
			SHIELD																																																																		
For signaling	Multiturn type encoder cable (small capacity)	<p>APCS-E□□□ES1-□</p> <p>*Front : APCS-E□□□ES1 (Load direction)</p> <p>* Rear : APCS-E□□□ES1-R (Rear direction)</p>	All models of APM-FB APM-FC Series	 <p><b>Motor connector</b></p> <table border="1"> <thead> <tr> <th>핀 번호</th> <th>Encoder 신호</th> </tr> </thead> <tbody> <tr><td>1</td><td>MA</td></tr> <tr><td>2</td><td>SLO</td></tr> <tr><td>3</td><td>GND B</td></tr> <tr><td>4</td><td>0V</td></tr> <tr><td>5</td><td>Shield</td></tr> <tr><td>6</td><td>HA</td></tr> <tr><td>7</td><td>SLO</td></tr> <tr><td>8</td><td>VDD B</td></tr> <tr><td>9</td><td>+5V</td></tr> </tbody> </table> <p><b>Drive connector (CN2)</b></p> <table border="1"> <thead> <tr> <th>핀 번호</th> <th>Encoder 신호</th> <th>핀 번호</th> <th>Encoder 신호</th> </tr> </thead> <tbody> <tr><td>1</td><td>-</td><td>8</td><td>-</td></tr> <tr><td>2</td><td>-</td><td>9</td><td>-</td></tr> <tr><td>3</td><td>MA</td><td>10</td><td>-</td></tr> <tr><td>4</td><td>HA</td><td>11</td><td>-</td></tr> <tr><td>5</td><td>SLO</td><td>12</td><td>-</td></tr> <tr><td>6</td><td>SLO</td><td>13</td><td>-</td></tr> <tr><td>7</td><td>0V</td><td>14</td><td>+5V</td></tr> <tr><td></td><td></td><td></td><td>SHIELD</td></tr> </tbody> </table> <p><b>Battery connector</b></p> <table border="1"> <thead> <tr> <th>핀 번호</th> <th>Encoder 신호</th> <th>신호</th> </tr> </thead> <tbody> <tr><td>1</td><td>BATTERY</td><td>BAE</td></tr> <tr><td>2</td><td>BATTERY 0V</td><td>0V</td></tr> </tbody> </table> <ol style="list-style-type: none"> <li>Motor connection <ul style="list-style-type: none"> <li>a. Cap specifications: 2201825-1(Tyco)</li> <li>b. Socket specifications : 2174065-4(Tyco )</li> </ul> </li> <li>Drive connection (CN2) <ul style="list-style-type: none"> <li>a. Case specifications: 10314-52A0-008(3M) or SM-14J(Suntone)</li> <li>b.Connector specifications: 10114-3000VE(3M) or SM-14J(Suntone)</li> </ul> </li> <li>Cable specifications: 4Px0.2SQ or 4Px24AWG</li> </ol>	핀 번호	Encoder 신호	1	MA	2	SLO	3	GND B	4	0V	5	Shield	6	HA	7	SLO	8	VDD B	9	+5V	핀 번호	Encoder 신호	핀 번호	Encoder 신호	1	-	8	-	2	-	9	-	3	MA	10	-	4	HA	11	-	5	SLO	12	-	6	SLO	13	-	7	0V	14	+5V				SHIELD	핀 번호	Encoder 신호	신호	1	BATTERY	BAE	2	BATTERY 0V	0V
핀 번호	Encoder 신호																																																																				
1	MA																																																																				
2	SLO																																																																				
3	GND B																																																																				
4	0V																																																																				
5	Shield																																																																				
6	HA																																																																				
7	SLO																																																																				
8	VDD B																																																																				
9	+5V																																																																				
핀 번호	Encoder 신호	핀 번호	Encoder 신호																																																																		
1	-	8	-																																																																		
2	-	9	-																																																																		
3	MA	10	-																																																																		
4	HA	11	-																																																																		
5	SLO	12	-																																																																		
6	SLO	13	-																																																																		
7	0V	14	+5V																																																																		
			SHIELD																																																																		
핀 번호	Encoder 신호	신호																																																																			
1	BATTERY	BAE																																																																			
2	BATTERY 0V	0V																																																																			

**Note 1)** The □□□ in the name indicates the type and length of each cable. Refer to the following table for this information

Cable length (m)	3	5	10	20
Robot cable	F03	F05	F10	F20
Regular cable	N03	N05	N10	N20

Category	Product Name	Name (Note 1)	Applicable Motors	Specifications
For signaling	Serial type encoder cable (medium capacity)	APCS-E□□□DS	All models of APM-SE APM-SF APM-SG APM-LF APM-LG APM-FE APM-FF APM-FG Series	<p>1. Motor connection (MS: Military Standard)                      a. Plug specifications : MS3108B(MS3106B) 20-29S                      2. Drive connection (CN2)                      a. Case specifications: 10314-52A0-008(3M) or SM-14J(Suntone)                      b. Connector specifications: 10114-3000VE(3M) or SM-14J(Suntone)                      3. Cable specifications: 4Px0.2SQ or 4Px24AWG</p>
For signaling	Multiturn type encoder cable (medium capacity)	ACS-E□□□DS1	All models of APM-SE APM-SF APM-SG APM-LF APM-LG APM-FE APM-FF APM-FG Series	<p>1. Motor connection                      a. Cap specifications (9 Position) : 172161-1(AMP)                      b. Socket specifications : 170361-1(AMP)                      2. Drive connection (CN2)                      a. Case specifications : 10314-52A0-008(3M) or SM-14J(Suntone)                      b. Connector specifications : 10114-3000VE(3M) or SM-14J(Suntone)                      3. Cable specifications : 4Px0.2SQ or 4Px24AWG</p>

**Note 1)** The □□□ in the name indicates the type and length of each cable. Refer to the following table for this information

Cable length (m)	3	5	10	20
Robot cable	F03	F05	F10	F20
Regular cable	N03	N05	N10	N20

■ Optional power cable

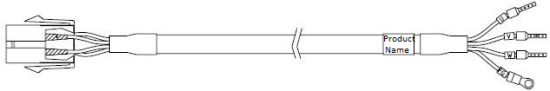
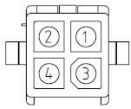
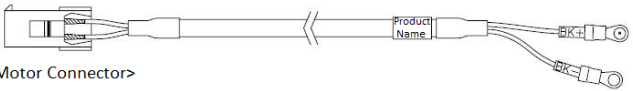
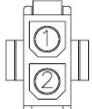
Category	Product Name	Name (Note 1)	Applicable Motors	Specifications													
For power	Standard power cable (Small capacity)	APCS-P□□□GS	All models of APM-SA, APM-SB, APM-SC and APM-HB Series	<p>Motor connection <span style="float: right;">Drive connection</span></p>  <div style="display: flex; justify-content: space-around; align-items: center;">  <table border="1" data-bbox="1123 555 1347 707"> <thead> <tr> <th>Content</th> <th>Signal</th> <th>Pin No.</th> </tr> </thead> <tbody> <tr> <td rowspan="3">LEAD WIRE</td> <td>U</td> <td>1</td> </tr> <tr> <td>V</td> <td>2</td> </tr> <tr> <td>W</td> <td>3</td> </tr> <tr> <td>Ground Line</td> <td>Ground</td> <td>4</td> </tr> </tbody> </table> </div> <p style="text-align: center;">&lt;Motor Connector&gt;</p> <ol style="list-style-type: none"> <li>1. Motor connection             <ol style="list-style-type: none"> <li>a. Cap specifications (4 positions): 172159-1 (AMP)</li> <li>b. Socket specifications: 170362-1 (AMP)</li> </ol> </li> <li>2. Drive connection (U, V, W, and FG)             <ol style="list-style-type: none"> <li>a. 1) U, V and W pin specifications: UA-F1512(SEOIL)</li> <li>b. 2) FG pin specifications: 1.5-4 (Ring terminal)</li> </ol> </li> <li>3. Cable specifications: 4Cx0.75SQ or 4Cx18(AWG18)</li> </ol>	Content	Signal	Pin No.	LEAD WIRE	U	1	V	2	W	3	Ground Line	Ground	4
Content	Signal	Pin No.															
LEAD WIRE	U	1															
	V	2															
	W	3															
Ground Line	Ground	4															
For power	Brake power cable (Small capacity)	APC-P□□□KB	All models of APM-SA APM-SB APM-SC Series	<p>Motor connection <span style="float: right;">Power Supply (DC24V)</span></p>  <div style="display: flex; justify-content: space-around; align-items: center;">  <table border="1" data-bbox="1075 1308 1353 1420"> <thead> <tr> <th>Content</th> <th>Signal</th> <th>Pin No.</th> </tr> </thead> <tbody> <tr> <td rowspan="2">BRAKE WIRE</td> <td>+</td> <td>1</td> </tr> <tr> <td>-</td> <td>2</td> </tr> </tbody> </table> </div> <p style="text-align: center;">&lt;Motor Connector&gt; <span style="float: right;">&lt;Braking Power&gt;</span></p> <ol style="list-style-type: none"> <li>1. Motor connection             <ol style="list-style-type: none"> <li>a. Cap specifications (6 positions): 172157-1 (AMP)</li> <li>b. Socket specifications: 170362-1 (AMP)</li> </ol> </li> <li>2. For braking power             <ol style="list-style-type: none"> <li>a. Connection terminal specifications: 1.5x3 (Ring Terminal)</li> <li>b. Cable specifications: 2Cx0.75SQ or 2Cx18 (AWG18)</li> </ol> </li> </ol>	Content	Signal	Pin No.	BRAKE WIRE	+	1	-	2					
Content	Signal	Pin No.															
BRAKE WIRE	+	1															
	-	2															

Category	Product Name	Name (Note 1)	Applicable Motors	Specifications																		
For power	Standard power cable	APCS-P□□□HS	All models of APM-SE APM-FE APM-HE Series	<div style="display: flex; justify-content: space-between;"> <span>Motor connection</span> <span>Drive connection</span> </div> <table border="1" style="margin-left: auto; margin-right: auto;"> <thead> <tr> <th>Content</th> <th>Signal Name</th> <th>Pin No.</th> </tr> </thead> <tbody> <tr> <td rowspan="4">Motor Wire</td> <td>U</td> <td>A</td> </tr> <tr> <td>V</td> <td>B</td> </tr> <tr> <td>W</td> <td>C</td> </tr> <tr> <td>Ground</td> <td>D</td> </tr> </tbody> </table> <p style="text-align: center;">&lt;Motor Connector&gt;</p> <ol style="list-style-type: none"> <li>1. Motor connection (MS : Military Standard)             <ol style="list-style-type: none"> <li>a. Plug specifications: MS3108B(MS3106B)20-4S</li> </ol> </li> <li>2. Drive connection (U,V,W,FG)             <ol style="list-style-type: none"> <li>a. U, V and W pin specifications: 2512</li> <li>b. FG pin specifications: 2.5x4(Ring Terminal)</li> </ol> </li> <li>3. Cable specifications: 4Cx2.5SQ or 4Cx14AWG</li> </ol>	Content	Signal Name	Pin No.	Motor Wire	U	A	V	B	W	C	Ground	D						
Content	Signal Name	Pin No.																				
Motor Wire	U	A																				
	V	B																				
	W	C																				
	Ground	D																				
For power	Power cable (brake type)	APCS-P□□□NB	All models of APM-SE APM-FE Series	<div style="display: flex; justify-content: space-between;"> <span>Motor connection</span> <span>Drive connection</span> </div> <table border="1" style="margin-left: auto; margin-right: auto;"> <thead> <tr> <th>Content</th> <th>Lead Wire</th> <th>Pin No.</th> </tr> </thead> <tbody> <tr> <td rowspan="4">Motor Wire</td> <td>U</td> <td>A</td> </tr> <tr> <td>V</td> <td>B</td> </tr> <tr> <td>W</td> <td>C</td> </tr> <tr> <td>Ground</td> <td>D</td> </tr> <tr> <td>Brake Wire</td> <td>+</td> <td>E</td> </tr> <tr> <td></td> <td>-</td> <td>F</td> </tr> </tbody> </table> <p style="text-align: center;">&lt;Motor connection&gt;</p> <ol style="list-style-type: none"> <li>1. Motor connection             <ol style="list-style-type: none"> <li>a. Plug specifications: MS3108B20-15S(MS 사)</li> </ol> </li> <li>2. Drive connection             <ol style="list-style-type: none"> <li>a. U, V and W pin specifications: 2012</li> <li>b. Cable specifications: 4C x 2.5SQ or 4C x 12AWG</li> <li>c. FG pin specifications: 2.5 x 4(Ring Terminal)</li> </ol> </li> <li>3. Brake power connection             <ol style="list-style-type: none"> <li>a. BK pin specifications: 1.5 x 3(Ring Terminal)</li> <li>b. Cable specifications: 2C x 0.75SQ or 2C x 18AWG</li> </ol> </li> </ol>	Content	Lead Wire	Pin No.	Motor Wire	U	A	V	B	W	C	Ground	D	Brake Wire	+	E		-	F
Content	Lead Wire	Pin No.																				
Motor Wire	U	A																				
	V	B																				
	W	C																				
	Ground	D																				
Brake Wire	+	E																				
	-	F																				

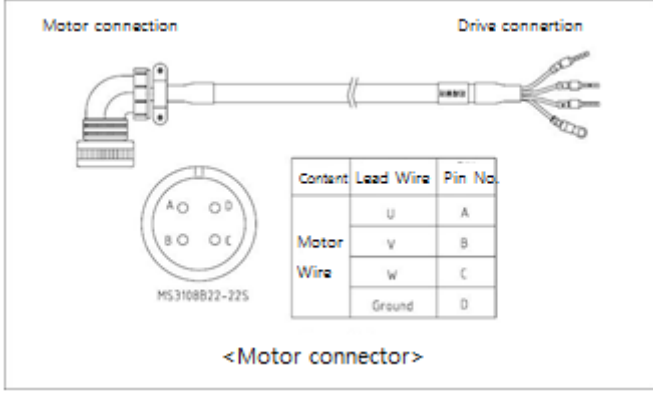
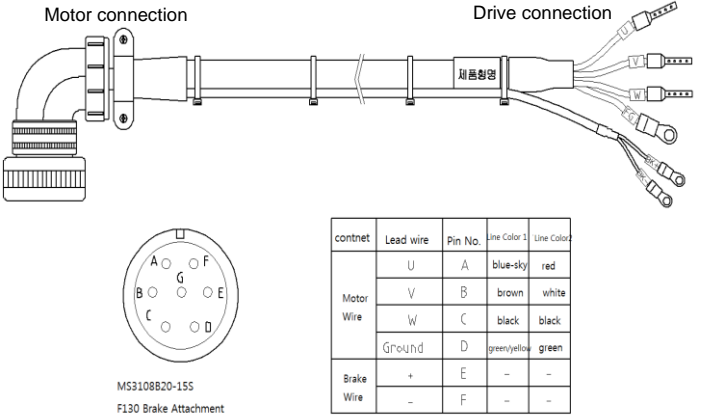

Category	Product Name	Name (Note 1)	Applicable Motors	Specifications																															
For power	Standard power cable	APCS-P□□□IS	All models of APM-SF APM-SG APM-FF APM-FG Series Below 3.5KW	 <table border="1" data-bbox="1109 470 1316 638"> <thead> <tr> <th>Content</th> <th>Lead Wire</th> <th>Pin No.</th> </tr> </thead> <tbody> <tr> <td rowspan="3">Motor Wire</td> <td>U</td> <td>A</td> </tr> <tr> <td>V</td> <td>B</td> </tr> <tr> <td>W</td> <td>C</td> </tr> <tr> <td></td> <td>Ground</td> <td>D</td> </tr> </tbody> </table> <p data-bbox="1037 660 1244 683">&lt;Motor connector&gt;</p> <ol style="list-style-type: none"> <li>1. Motor connection (MS : Military Standard)             <ol style="list-style-type: none"> <li>a. Plug specifications: MS3108B(MS3106B)22-22S</li> </ol> </li> <li>2. Drive connection (U,V,W,FG)             <ol style="list-style-type: none"> <li>a. U, V and W pin specifications: F2512</li> <li>b. FG pin specifications: 2.5x4 (Ring Terminal)</li> </ol> </li> <li>3. Cable specifications: 4Cx2.5SQ or 4Cx14AWG</li> </ol>	Content	Lead Wire	Pin No.	Motor Wire	U	A	V	B	W	C		Ground	D																		
Content	Lead Wire	Pin No.																																	
Motor Wire	U	A																																	
	V	B																																	
	W	C																																	
	Ground	D																																	
For power	Power cable (brake type)	APCS-P□□□PB	All models of APM-SF APM-LF APM-FF Series Below 3.5KW	 <table border="1" data-bbox="1149 1209 1396 1400"> <thead> <tr> <th>Content</th> <th>Lead wire</th> <th>Pin No.</th> <th>Line Color 1</th> <th>Line Color 2</th> </tr> </thead> <tbody> <tr> <td rowspan="4">Motor Wire</td> <td>U</td> <td>A</td> <td>blue-sky</td> <td>red</td> </tr> <tr> <td>V</td> <td>B</td> <td>brown</td> <td>white</td> </tr> <tr> <td>W</td> <td>C</td> <td>black</td> <td>black</td> </tr> <tr> <td>Ground</td> <td>D</td> <td>green/yellow</td> <td>green</td> </tr> <tr> <td rowspan="2">Brake Wire</td> <td>+</td> <td>E</td> <td>-</td> <td>-</td> </tr> <tr> <td>-</td> <td>F</td> <td>-</td> <td>-</td> </tr> </tbody> </table> <p data-bbox="1053 1422 1228 1444">&lt;Motor connection&gt;</p> <ol style="list-style-type: none"> <li>1. Motor connection             <ol style="list-style-type: none"> <li>a. Plug specifications: MS3108B24-10S(MS 사)</li> </ol> </li> <li>2. Drive connection             <ol style="list-style-type: none"> <li>a. Cable specifications: 4C x 2.5SQ or 4C x 14AWG</li> <li>b. pin specifications: 2.5 x 4(Ring Terminal)</li> </ol> </li> <li>3. Brake power connection             <ol style="list-style-type: none"> <li>a. BK pin specifications: 1.5 x 3(Ring Terminal)</li> <li>b. pin specifications: 2C x 0.75SQ or 2C x 18AW</li> </ol> </li> </ol>	Content	Lead wire	Pin No.	Line Color 1	Line Color 2	Motor Wire	U	A	blue-sky	red	V	B	brown	white	W	C	black	black	Ground	D	green/yellow	green	Brake Wire	+	E	-	-	-	F	-	-
Content	Lead wire	Pin No.	Line Color 1	Line Color 2																															
Motor Wire	U	A	blue-sky	red																															
	V	B	brown	white																															
	W	C	black	black																															
	Ground	D	green/yellow	green																															
Brake Wire	+	E	-	-																															
	-	F	-	-																															

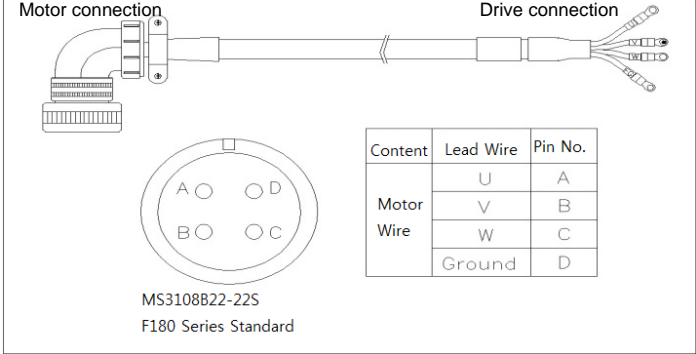
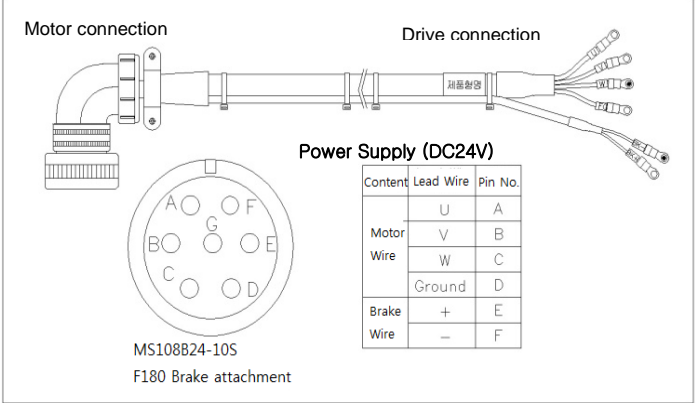
Category	Product Name	Name (Note 1)	Applicable Motors	Specifications																	
For power	Standard power cable	APCS-P□□□JS (new model)	All models of APM-SF APM-SG APM-FF APM-FG Series above 3.5KW below 5KW	 <p>MS3108B22-225 F180 Series Standard</p> <table border="1" data-bbox="1145 443 1382 591"> <thead> <tr> <th>Content</th> <th>Lead Wire</th> <th>Pin No.</th> </tr> </thead> <tbody> <tr> <td rowspan="4">Motor Wire</td> <td>U</td> <td>A</td> </tr> <tr> <td>V</td> <td>B</td> </tr> <tr> <td>W</td> <td>C</td> </tr> <tr> <td>Ground</td> <td>D</td> </tr> </tbody> </table> <ol style="list-style-type: none"> <li>1. Motor connection (MS : Military Standard)                         <ol style="list-style-type: none"> <li>a. Plug specifications: MS3108B(MS3106B)22-22S</li> </ol> </li> <li>2. Drive connection (U,V,W,FG)                         <ol style="list-style-type: none"> <li>a. U,V and W pin specifications: 6012</li> <li>b. FG pin specifications: 6.0 x 5 (Ring Terminal)</li> </ol> </li> <li>3. Cable specifications: 4Cx6.0SQ or 4Cx10AWG</li> </ol>	Content	Lead Wire	Pin No.	Motor Wire	U	A	V	B	W	C	Ground	D					
Content	Lead Wire	Pin No.																			
Motor Wire	U	A																			
	V	B																			
	W	C																			
	Ground	D																			
For power	Power cable (brake type)	APCS-P□□□LB (new model)	All models of APM-SF APM-LF APM-FF Series above 3.5KW below 5KW	 <p>MS108B24-10S F180 Brake attachment</p> <table border="1" data-bbox="1145 1093 1305 1276"> <thead> <tr> <th>Content</th> <th>Lead Wire</th> <th>Pin No.</th> </tr> </thead> <tbody> <tr> <td rowspan="4">Motor Wire</td> <td>U</td> <td>A</td> </tr> <tr> <td>V</td> <td>B</td> </tr> <tr> <td>W</td> <td>C</td> </tr> <tr> <td>Ground</td> <td>D</td> </tr> <tr> <td rowspan="2">Brake Wire</td> <td>+</td> <td>E</td> </tr> <tr> <td>-</td> <td>F</td> </tr> </tbody> </table> <ol style="list-style-type: none"> <li>1. Motor connection                         <ol style="list-style-type: none"> <li>a. Plug specifications: MS3108B24-10S(MS)</li> </ol> </li> <li>2. Drive connection                         <ol style="list-style-type: none"> <li>a. Cable specifications: 4C x 2.5SQ or 4C x 14AWG</li> <li>b. pin specifications: 2.5 x 4(Ring Terminal)</li> </ol> </li> <li>3. Brake power connection                         <ol style="list-style-type: none"> <li>a. BK pin specifications: 1.5 x 3(Ring Terminal)</li> </ol> </li> <li>4. Cable specifications: 2C x 0.75SQ or 2C x 18AW</li> </ol>	Content	Lead Wire	Pin No.	Motor Wire	U	A	V	B	W	C	Ground	D	Brake Wire	+	E	-	F
Content	Lead Wire	Pin No.																			
Motor Wire	U	A																			
	V	B																			
	W	C																			
	Ground	D																			
Brake Wire	+	E																			
	-	F																			

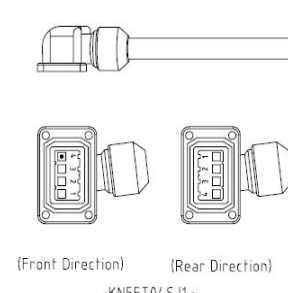
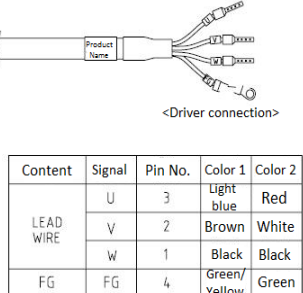
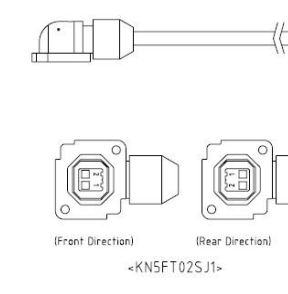
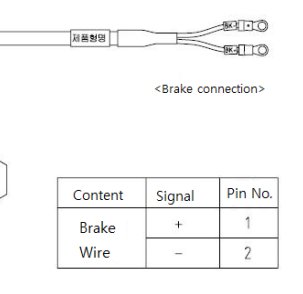

Category	Product Name	Name (Note 1)	Applicable Motors	Specifications																							
For power	Flat motor Power cable	<p>APCS- □□□FS-□</p> <p>*Front : APCS- P□□□FS (Load direction)</p> <p>* Rear : APCS- P□□□FS-R (Rear direction)</p>	All models of APM-FB APM-FC Series	<div style="display: flex; justify-content: space-between;"> <div style="width: 45%;"> <p>Motor connection</p>  <p style="text-align: center;">&lt;KN5FT04SJ1 &gt;</p> <p style="text-align: center;">&lt;Motor connection&gt;</p> </div> <div style="width: 45%;"> <p>Drive connection</p>  <table border="1" style="margin-left: auto; margin-right: auto;"> <thead> <tr> <th>Content</th> <th>Signal</th> <th>Pin No.</th> <th>Color 1</th> <th>Color 2</th> </tr> </thead> <tbody> <tr> <td rowspan="3">LEAD WIRE</td> <td>U</td> <td>3</td> <td>Light blue</td> <td>Red</td> </tr> <tr> <td>V</td> <td>2</td> <td>Brown</td> <td>White</td> </tr> <tr> <td>W</td> <td>1</td> <td>Black</td> <td>Black</td> </tr> <tr> <td>FG</td> <td>FG</td> <td>4</td> <td>Green/Yellow</td> <td>Green</td> </tr> </tbody> </table> </div> </div> <ol style="list-style-type: none"> <li>1. Motor connection             <ol style="list-style-type: none"> <li>a. Plug specifications: KN5FT04SJ1(JAE)</li> <li>b. Plug specifications: ST-KN-S-C1B-3500 (JAE)</li> </ol> </li> <li>2. Drive connection (U,V,W,FG)             <ol style="list-style-type: none"> <li>a. U,V and W pin specifications: 1512</li> <li>b. FG pin specifications: 1.5x4 (Ring Terminal)</li> </ol> </li> <li>3. Cable specifications: 4Cx0.75SQ or 4Cx18AWG</li> </ol>	Content	Signal	Pin No.	Color 1	Color 2	LEAD WIRE	U	3	Light blue	Red	V	2	Brown	White	W	1	Black	Black	FG	FG	4	Green/Yellow	Green
Content	Signal	Pin No.	Color 1	Color 2																							
LEAD WIRE	U	3	Light blue	Red																							
	V	2	Brown	White																							
	W	1	Black	Black																							
FG	FG	4	Green/Yellow	Green																							
For power	Flat motor brake cable	<p>APCS- B□□□QS</p> <p>*Front : APCS- B□□□QS (Load direction)</p> <p>* Rear : APCS- B□□□QS-R (Rear direction)</p>	All models of APM-FB APM-FC Series	<div style="display: flex; justify-content: space-between;"> <div style="width: 45%;"> <p>Motor connection</p>  <p style="text-align: center;">&lt;KN5FT02SJ1&gt;</p> <p style="text-align: center;">&lt;Motor connection&gt;</p> </div> <div style="width: 45%;"> <p>Drive connection</p>  <table border="1" style="margin-left: auto; margin-right: auto;"> <thead> <tr> <th>Content</th> <th>Signal</th> <th>Pin No.</th> </tr> </thead> <tbody> <tr> <td rowspan="2">Brake Wire</td> <td>+</td> <td>1</td> </tr> <tr> <td>-</td> <td>2</td> </tr> </tbody> </table> </div> </div> <ol style="list-style-type: none"> <li>1. Motor connection             <ol style="list-style-type: none"> <li>a. Plug specifications: KN5FT02SJ1(JAE )</li> <li>b. Socket specifications: ST-KN-S-C1B-3500 (JAE )</li> </ol> </li> <li>2. Brake power connection             <ol style="list-style-type: none"> <li>a. connection terminal specifications: 1.5x3(Ring Terminal)</li> </ol> </li> <li>3. Cable specifications: 2Cx0.75SQ or 2Cx18AWG</li> </ol>	Content	Signal	Pin No.	Brake Wire	+	1	-	2															
Content	Signal	Pin No.																									
Brake Wire	+	1																									
	-	2																									

Category	Product Name	Name (Note 1)	Applicable Motors	Specifications									
For power	Brake Power cable	APCS-P□□□SB (new model)	All models of APM-SG APM-LG APM-FG Series	<p>Motor connection                      Drive connection</p> <p>MS3108B14S-75</p> <table border="1"> <thead> <tr> <th>Content</th> <th>Signal</th> <th>Pin No.</th> </tr> </thead> <tbody> <tr> <td>Brake</td> <td>+</td> <td>A</td> </tr> <tr> <td>Wire</td> <td>-</td> <td>B</td> </tr> </tbody> </table> <p>&lt;Brake connection&gt;</p> <ol style="list-style-type: none"> <li>Motor connection             <ol style="list-style-type: none"> <li>Plug specifications: MS3108B14-7S(MS)</li> </ol> </li> <li>Brake power connection             <ol style="list-style-type: none"> <li>connection terminal specifications: 1.5x3(Ring Terminal)</li> </ol> </li> <li>Cable specifications: 2Cx0.75SQ or 2Cx19AWG</li> </ol>	Content	Signal	Pin No.	Brake	+	A	Wire	-	B
Content	Signal	Pin No.											
Brake	+	A											
Wire	-	B											

**Note 1)** The □□□ in the name indicates the type and length of each cable. Refer to the following table for this information.

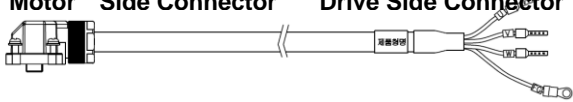

Cable length (m)	3	5	10	20
Robot cable	F03	F05	F10	F20
Regular cable	N03	N05	N10	N20

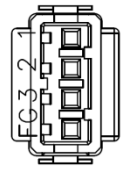
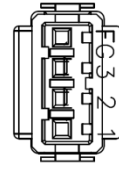
■ **Optional cables**

Category	Product Name	Type Name (Note 1)	Applicable Drive	Specifications															
For power	Power cable for L series (small capacitor)	APCS- P000LS(Front Direction)/ APCS- P000LS-R(Rear Direction)	All models of APM-FAL/FBL/FCL Series	<p><b>Motor Side Connector      Drive Side Connector</b></p>    <table border="1" data-bbox="1212 515 1348 604"> <thead> <tr> <th>내용</th> <th>신호</th> <th>핀 번호</th> </tr> </thead> <tbody> <tr> <td>U</td> <td></td> <td>1</td> </tr> <tr> <td>V</td> <td></td> <td>2</td> </tr> <tr> <td>W</td> <td></td> <td>3</td> </tr> <tr> <td>FG</td> <td>FG</td> <td>4</td> </tr> </tbody> </table> <p><b>1. Motor side connector</b>  a. PLUG : SM-JN8FT04 (Suntone사)  b. Socket : SMS-201 (Suntone사)</p> <p><b>2. Drive side connector (U,V,W,FG)</b>  a. U,V,W pin connection:1512  b. FG pin: 1.5x4 (Ring Terminal)</p> <p><b>3. Cable : 4Cx0.75SQ or 4Cx18AWG</b></p> <p><b>4. Remark: For FAL motor, after connect power cable first, connect Encoder cable</b></p>   <p>(Front Direction)      (Rear Direction)</p>	내용	신호	핀 번호	U		1	V		2	W		3	FG	FG	4
내용	신호	핀 번호																	
U		1																	
V		2																	
W		3																	
FG	FG	4																	

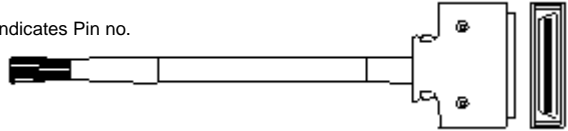
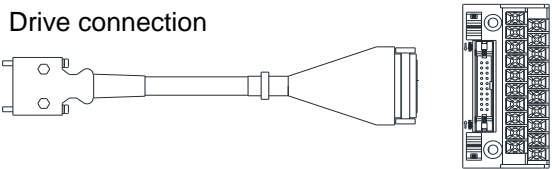
■ **Optional cables**

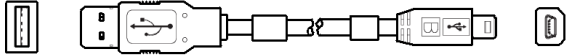
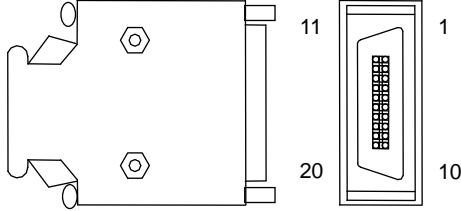
Category	Product Name	Name (Note 1)	Applicable Drive	Specifications										
For signaling	CN1 Cable	APCS-CN1□□A	L7N Series	<p>[Upper controller] [Servo drive – CN1]</p> <p>Indicates Pin no.</p>  <ol style="list-style-type: none"> <li>Drive connection (CN1)                             <ol style="list-style-type: none"> <li>Case specifications: 10320-52A0-008(3M)</li> <li>Connector specifications: 10120-3000PE(3M)</li> </ol> </li> <li>Cable specifications: ROW-SB0.1Cx20C(AWG28)</li> </ol>										
T/B	CN1 T/B	APCS-L7NCN1T-□□□	L7N SERIES	<p>Terminal block connection</p> <p>Drive connection</p>  <ol style="list-style-type: none"> <li>Drive connection (CN1)                             <ol style="list-style-type: none"> <li>CASE specification : 10320-52A0-008(3M)</li> <li>CONNECTOR specification : 10120-3000PE (3M)</li> <li>CABLE specification : AWG28 x 10P</li> </ol> </li> <li>Terminal block connection                             <ol style="list-style-type: none"> <li>CONNECTOR specification : HIF3BA-20D-2.54R(Hirose)</li> <li>Terminal block specification : XTB-20H(Samwon Act)</li> </ol> </li> <li>Cable length                             <table border="1"> <thead> <tr> <th>Serial No.</th> <th>H01</th> <th>H02</th> <th>H03</th> <th>H04</th> </tr> </thead> <tbody> <tr> <td>Length</td> <td>0.5m</td> <td>1m</td> <td>1.5m</td> <td>2m</td> </tr> </tbody> </table> </li> </ol>	Serial No.	H01	H02	H03	H04	Length	0.5m	1m	1.5m	2m
Serial No.	H01	H02	H03	H04										
Length	0.5m	1m	1.5m	2m										

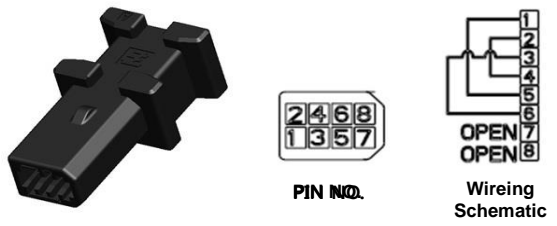
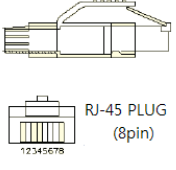
<p>For signaling</p>	<p>Communication cable</p>	<p>APCS-CN5L7U</p>	<p>L7 Series</p>	<p>[PC - USB port]                      [Servo drive – CN5]</p>  <ol style="list-style-type: none"> <li>1. PC connection: USB A plug</li> <li>2. Drive connection (CN5): Mini USB 5P plug</li> <li>3. Electrical requirements: Double shielded, twisted pair, EMI filter installation (similar product: KU-AMB518 by SANWA)</li> </ol>																														
<p>CN</p>	<p>CN1 Connector</p>	<p>APC-CN2NNA</p>	<p>L7N Series</p>	 <ol style="list-style-type: none"> <li>1. Case specifications: 10320-52A20-008(3M)</li> <li>2. Connector specifications: 10120-3000PE(3M)</li> </ol>																														
<p>CN</p>	<p>CN6 Connector</p>	<p>APCS-CN6J</p>	<p>L7N Series</p>	 <ol style="list-style-type: none"> <li>1. Plug Connector Kit : 2040008-1(TE)</li> </ol>																														
<p>CN</p>	<p>CN6 Connector</p>	<p>APCS-CN6K</p>	<p>L7N SERIES</p>	 <ol style="list-style-type: none"> <li>1. MINI I/O By-Pass Connector : 1971153(TE)</li> </ol>																														
<p>CN</p>	<p>CN3/4 Connector</p>	<p>APCS-CN4NNA</p>	<p>L7N Series</p>	 <table border="1" data-bbox="1109 1668 1356 1904"> <thead> <tr> <th>Pin</th> <th>Signal</th> <th>Color</th> </tr> </thead> <tbody> <tr> <td>1</td> <td>TX/RX0 Plus</td> <td>White/Orange</td> </tr> <tr> <td>2</td> <td>TX/RX0 Minus</td> <td>Orange</td> </tr> <tr> <td>3</td> <td>TX/RX1 Plus</td> <td>White/Green</td> </tr> <tr> <td>4</td> <td>TX/RX2 Plus</td> <td>Blue</td> </tr> <tr> <td>5</td> <td>TX/RX2 Minus</td> <td>White/Blue</td> </tr> <tr> <td>6</td> <td>TX/RX1 Minus</td> <td>Green</td> </tr> <tr> <td>7</td> <td>TX/RX3 Plus</td> <td>White/Brown</td> </tr> <tr> <td>8</td> <td>TX/RX3 Minus</td> <td>Brown</td> </tr> <tr> <td></td> <td>plate</td> <td>shield</td> </tr> </tbody> </table> <ol style="list-style-type: none"> <li>1. Connector specifications: 44915-0021(MOLEX)</li> <li>2. Plug Housing specifications: WRJ-45(WlzteK)</li> </ol>	Pin	Signal	Color	1	TX/RX0 Plus	White/Orange	2	TX/RX0 Minus	Orange	3	TX/RX1 Plus	White/Green	4	TX/RX2 Plus	Blue	5	TX/RX2 Minus	White/Blue	6	TX/RX1 Minus	Green	7	TX/RX3 Plus	White/Brown	8	TX/RX3 Minus	Brown		plate	shield
Pin	Signal	Color																																
1	TX/RX0 Plus	White/Orange																																
2	TX/RX0 Minus	Orange																																
3	TX/RX1 Plus	White/Green																																
4	TX/RX2 Plus	Blue																																
5	TX/RX2 Minus	White/Blue																																
6	TX/RX1 Minus	Green																																
7	TX/RX3 Plus	White/Brown																																
8	TX/RX3 Minus	Brown																																
	plate	shield																																

**Note 1)** The □□ in the name indicates the length of each cable. Refer to the following table for this information.

Cable length (m)	1	2	3	5
Indication	01	02	03	05

■ **Optional braking resistance**

Category	Product Name	Name	Applicable Drive	Specifications
Resistance	Braking resistance	APC-140R50	L7NA001B L7NA002B L7NA004B	
Resistance	Braking resistance	APC-300R30	L7NA008B L7NA010B	
Resistance	Braking resistance	APC-600R30	L7NA020B (2P) L7NA035B (3P)	



Resistance	Braking resistance	APC-600R28	L7NA050B (4P)	 

# 11. Maintenance and Inspection

## 11.1 Maintenance and Inspection

This chapter explains how to perform basic maintenance and inspection tasks as well as diagnose and troubleshoot the servo motor and drive.

### 11.1.1 Precautions

1. Measuring the motor voltage: The PWM controls the voltage output from the servo amp to the motor. Because of this, the waves take the form of pulses. Use a rectifier voltmeter for accurate measurements because different meters may produce different results.
2. Measuring the motor current: Use a moving iron ammeter and wait for the motor's reactance to smooth the pulse waveform into sine waves.
3. Measuring the electric power: Use an electro-dynamometer based on the 3 power meter method.
4. Other gauges: When using an oscilloscope or digital voltmeter, do not allow them to touch the ground. Use a 1 mA or less input current gauge.

### 11.1.2 What to Inspect

Wait at least 10 minutes after turning off the power before beginning the inspection because the condenser can hold enough voltage to cause an electrical accident.

#### (2) Inspecting the Servo Motor

<b>⚠ Caution</b>			
Wait at least 10 minutes after turning off the power before beginning the inspection because the condenser can hold enough voltage to cause an electrical accident.			

Inspection Item	Inspection Period	Inspection and Handling	Notes
Vibration and sound check	Monthly	Touch the motor and listen for sounds.	The feel and sounds should be the same as usual.
Inspect the exterior of the motor	Depends on the amount of contamination or damage.	Clean the motor with a cloth or air pressure.	-
Measure the insulation resistance	At least once a year	Disconnect the motor from the drive and measure the insulation resistance. A normal resistance level is 10 MΩ or higher. <small>Note 1)</small>	Contact our service center if the resistance is lower than 10 MΩ.
Replace the oil seal	At least once every 5,000 hours	Remove the oil seal from the motor and replace it.	This only applies to motors with an oil seal.

Inspection Item	Inspection Period	Inspection and Handling	Notes
General inspection	At least once every 20,000 hours or after 5 years.	Contact our service center.	Do not disassemble the servo motor yourself.

**Note 1)** Measure the resistance between the FG and one of the U, V, and W power lines on the servo motor.

### (3) Inspecting the Servo Drive

Inspection Item	Inspection Period	Inspection process	What to do if you find an abnormality
Clean the main body and control board	At least once a year	Check if there is any dust or oil on the components.	Clean it with air pressure or a cloth.
Check for loose screws	At least once a year	Check whether the screws are loose on the terminals and connectors.	Tighten the screws.
Check for defective parts on the main body or the control board	At least once a year	Check for discoloration, damage, or disconnection caused by heat.	Contact our company.

## 11.1.3 Replacing Parts

Mechanical friction and aging may deteriorate the following parts or even cause them to malfunction. This makes it important to conduct regular maintenance checks and replace worn parts.

1. The smoothing condenser: Ripple currents and other factors can cause this part to wear. The lifespan of this part depends on the operating temperature and environment. It normally lasts for 10 years if used continuously in a normal air-conditioned environment. Inspect the condenser at least once each year because it can rapidly age over a short period of time once it starts to deteriorate (inspect it more frequently as it approaches obsolescence).
  - ※ Visual inspection criteria:
    - a. The condition of the case: Check for deformations on the sides and bottom.
    - b. The condition of the lid: Check for notable expansion, severe cracks, or broken parts.
    - c. The relief valve: Check for notable valve expansion and operation.
    - d. Also regularly check whether the exterior is cracked, discolored, or leaking and whether there are any broken parts. The condenser is obsolete when its capacity degrades to less than 85% of the rated capacity.
2. The relays: Check for bad connections and wear and tear on the contacts caused by switching currents. A relay is obsolete when its accumulated number of switches reaches 100,000, depending on the power capacity.
3. Motor bearings: Replace the bearings after 20,000 to 30,000 hours of operation at the rated speed under the rated load. Replace the bearings if abnormal sounds or vibrations are detected during inspection, depending on the operating conditions.

### The Standard Part Replacement Cycle

Part Name	Standard Replacement Cycle	Method
Smoothing condenser	7-8 years	Replace (determine after inspection).
Relays	-	Determine after inspection
Fuses	10 years	Replace
Aluminum electrolytic condensers on printed boards	5 years	Replace with new boards (determined after inspection)
Cooling fans	4-5 years	Replace
Motor bearings	-	Determine after inspection
Motor oil seal	5,000 hours	Replace

## 11.2 Diagnosing and Troubleshooting Abnormalities

AL-□ appears if a problem occurs during operation. If this happens, try to solve the problem by following the troubleshooting advice given in this section. If the problem persists, contact our service center.

### 11.2.1 The Servo Motor

#### Cause of abnormalities, inspection procedure, and troubleshooting methods

Symptoms	Causes	Inspection process	Remedies
The motor does not move.	The P-OT and N-OT inputs are off.	Refer to section 3.6, "Signals."	Turn on the P-OT and N-OT inputs.
	The motor has defects.	Use a resistance tester to measure the resistance to the motor lead terminal (resistance between phases: several ohms).	Replace the motor.
	The locking screws are loose.	Check the locking screws.	Tighten any loose screws.
	The external wiring is incorrect or the cables are disconnected.	Check the wires to the motor and the encoder.	Redo the wiring. Replace the cables.
	The encoder has defects.	Check the output waves.	Replace the encoder. (Contact our service center.)
Motor rotation is unstable.	The connection is bad.	Check the connection of the motor lead terminal.	Fix any bad connections.
	The input voltage is low.	Check the input voltage of the drive.	Change the power source.
	Overloads occur.	Check the condition of the machine.	Remove any foreign substances from the rotating unit and grease or lubricate it.
The motor overheats.	The ambient temperature is too high.	Check the temperature around the motor. (40°C or lower)	Change heat transfer structure. Install a cooling fan.
	The surface of the motor is contaminated.	Check whether there are any foreign substances on the surface of the motor.	Clean the surface of the motor.
	Overloads occur.	Check the load on the drive. Check the acceleration/deceleration time.	Reduce the load. Increase the acceleration/deceleration time. Use a motor with a greater capacity.
	The magnetic power of the magnets is reduced.	Check the counter voltage and voltage waveforms.	Replace the motor.
The device is making a strange sound.	Coupling is bad.	Tighten the coupling screws and measure the concentricity of the connection.	Readjust the coupling.
	The bearings are abnormal.	Check the bearings for vibrations and sounds.	Contact us.
	The parameters are set incorrectly (the inertia, gain, and time constants).	Check the parameters.	Refer to Chapter 6, "Object Dictionary."











## 11.2.2 The Servo Drive

If an alarm occurs, then the malfunction signal output contact (ALARM) goes off and the dynamic brake stops the motor.

Alarm Code	Name	Details	What to check
AL-10	IPM Fault	Overcurrent (H/W)	Check for incorrect wiring in the drive output and encoder. Check the motor ID, drive ID, and encoder settings. Determine whether there is a conflict or binding in the equipment.
AL-11	IPM temperature	IPM overheat	Check for incorrect wiring in the drive output and encoder. Check the motor ID, drive ID, and encoder settings. Determine whether there is a conflict or binding in the equipment.
AL-14	Overcurrent	Overcurrent (S/W)	Check for incorrect wiring in the drive output and encoder. Check the motor ID, drive ID, and encoder settings. Determine whether there is a conflict or binding in the equipment.
AL-15	Current offset	Abnormal current offset	Check whether the U-phase current offset [0x2614] and V-phase current offset [0x2615] are 5% of the rated current or higher. Replace the drive.
AL-16	Overcurrent (/CL)	Overcurrent (H/W)	Check for incorrect wiring in the drive output and encoder. Check the motor ID, drive ID, and encoder settings. Determine whether there is a conflict or binding in the equipment.
AL-21	Continuous overload	Continuous overload	Determine whether there is a conflict or binding in the equipment. Check the load and the condition of the brake. Check for incorrect wiring in the drive output and encoder. Check the motor ID and encoder settings.
AL-22	Room temperature	Drive overheat	Check the temperature inside the drive [0x2610]. Install a cooling fan and check the load.
AL-23	Regen. Overload	Regenerative overload	Check the input voltage, regenerative braking resistance, and wiring. Replace the drive.
AL-24	Motor cable open	Motor disconnection	Check the wiring of the motor.
AL-30	Encoder comm.	Serial encoder communication error	Check for incorrect wiring of the serial encoder.
AL-31	Encoder cable open	Encoder cable disconnection	Check whether the encoder cable is disconnected.

Alarm Code	Name	Details	What to check
AL-32	Encoder data error	Encoder data error	Check the encoder settings and wiring.
AL-33	Motor setting error	Motor ID setting error	Replace the encoder.
AL-35	Low Battery Error	Low voltage error	Low voltage of Back Up battery, when Absolute encoder is applied. ※ Reset the operation after changing battery. (Applied after S/W Ver 1.3)
AL-40	Under voltage	Low voltage	Check input voltage and power unit wiring.
AL-41	Overvoltage	Overvoltage	Check the input voltage and wiring. Check the braking resistance for damage. Check for excessive regenerative operation. Check the regenerative resistance.
AL-42	RST power fail	Main power failure	Check the power unit wiring and power supply.
AL-43	Control power fail	Control power failure	Check the power unit wiring and power supply.
AL-50	Over speed limit	Overspeed	Check the encoder, encoder settings, encoder wiring, gain settings, motor wiring, motor ID, electric gear ratio, and speed command scale.
AL-51	Position following	Excessive position error	Check the Following Error Window [0x6065], wiring and limit contacts, gain setting values, encoder settings, and electric gear ratio settings. Check the load on the equipment and whether there is binding on the equipment.
AL-54	Encoder Position Difference	Difference between 2 encoders	Check value of difference between internal and external encoder or external encoder when Full-Closed control
AL-65	EtherCAT Comm.Err 1	EtherCAT communication malfunction	Check the CN3 and CN4 connectors and the EtherCAT communication cable. Replace the drive.
AL-66	EtherCAT Comm.Err 2		
AL-67	EtherCAT Comm.Err 3		
AL-71	Invalid factory setting	Invalid factory settings	Restore the default parameters [0x1011].
AL-72	GPIO setting	Output contact point setting error	Restore the default parameters [0x1011].

A warning code appears in the current operation status [St-00] if the servo drive is operating abnormally. Check the warning code to determine what you need to inspect. For EMG [W-80] errors, however, the dynamic brake stops the motor.

Warning State (CODE)	Name	Details and causes	What to check
	RST_PFAIL	Main power phase loss	The equipment does not receive main power when the handling method for the main power phase loss [0x2003] is set to 1.
	LOW_BATT	Low battery	The output voltage of the encoder backup battery is insufficient when applying an absolute encoder.
	OV_TCMD	Excessive Torque Command	You have exceeded the maximum number of torque commands.
	OV_VCMD	Excessive speed command	You have exceeded the maximum number of speed commands.
	OV_LOAD	Overload warning	The accumulated overload has reached the overload warning level [0x200A].
	SETUP	Capacity settings	The electric current capacity of the motor is larger than that of the drive.
	UD_VTG	Low voltage warning	The DC-link voltage is 190V or below when second bit of [0x2003] is set to 1.
	EMG	EMG warning	Check the emergency stop contact signal and the external 24 V power.
	STO connection error	STO connection error	Check the operation and connection setting.
	CCW Limit	CCW Limit on setting	Check the setting and point of contact.
	CW Limit	CW Limit on setting	Check the setting and point of contact.



■ Servo Drive Overload Graphs (400 W or less)

(1) Rotation overload graph

Load (%)	AL-21 Occurring Time (sec)	Max	Min	Load (%)	AL-21 Occurring Time (sec)	Max	Min
100% or less	∞						
110	55776.0	89241.6	33465.6	210	66.8	106.9	40.08
120	13944.0	22310.4	8366.4	220	50.1	80.2	30.06
130	6197.3	9915.7	3718.38	230	38.5	61.6	23.1
140	3486.0	5577.6	2091.6	240	30.3	48.5	18.18
150	1183.0	1892.8	709.8	250	24.2	38.7	14.52
160	566.0	905.6	339.6	260	4.2	6.7	2.52
170	318.0	508.8	190.8	270	3.8	6.1	2.28
180	198.0	316.8	118.8	280	3.4	5.4	2.04
190	131.0	209.6	78.6	290	3.0	4.8	1.8
200	92.0	147.2	55.2	300	2.7	4.3	1.62

Load curve during rotation

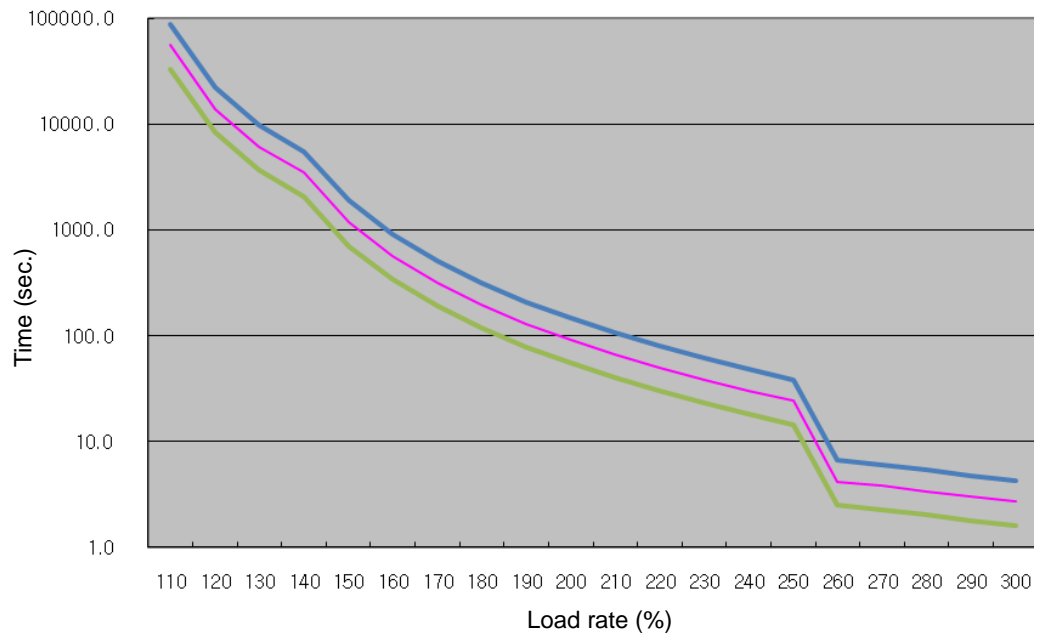

**(2) Stoppage overload graph**

Load (%)	AL-21 Occurring Time (sec)	Max	Min	Load (%)	AL-21 Occurring Time (sec)	Max	Min
100% or less	∞						
110	37937.7	60700.3	22762.62	210	50.1	80.2	30.06
120	9483.9	15174.2	5690.34	220	38.5	61.6	23.1
130	4215.1	6744.2	2529.06	230	30.3	48.5	18.18
140	2371.0	3793.6	1422.6	240	9.7	15.5	5.82
150	926.0	1481.6	555.6	250	8.3	13.3	4.98
160	470.0	752.0	282	260	3.8	6.1	2.28
170	273.0	436.8	163.8	270	3.4	5.4	2.04
180	173.0	276.8	103.8	280	3.1	5.0	1.86
190	117.0	187.2	70.2	290	2.7	4.3	1.62
200	66.0	105.6	39.6	300	2.5	4.0	1.5

Load curve when stopped

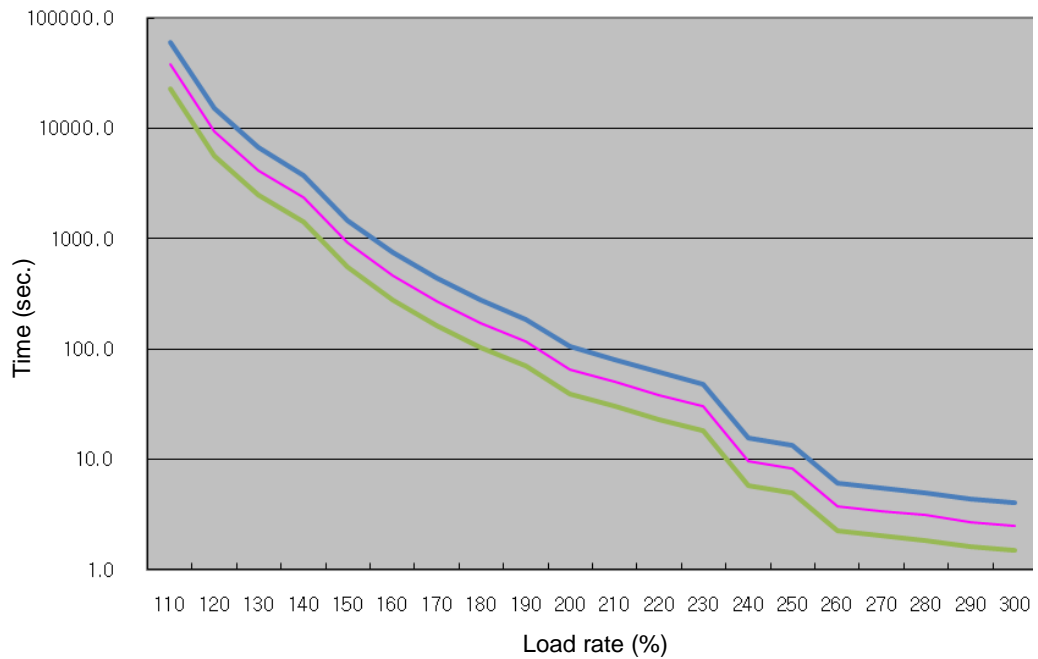

■ Servo Drive Overload Graphs (SA type, 100 W or less)

(1) Rotation overload graph

Load (%)	AL-21 Occurring Time (sec)	Max	Min	Load (%)	AL-21 Occurring Time (sec)	Max	Min
100% or less	∞						
110	1696.0	2713.6	1017.6	210	5.2	8.3	3.12
120	424.0	678.4	254.4	220	4.4	7.0	2.64
130	188.4	301.5	113.064	230	3.8	6.1	2.28
140	106.0	169.6	63.6	240	3.3	5.3	1.98
150	70.4	112.6	42.24	250	2.9	4.6	1.74
160	26.8	42.9	16.08	260	2.6	4.2	1.56
170	20.6	33.0	12.36	270	2.3	3.7	1.38
180	16.2	25.9	9.72	280	2.0	3.2	1.2
190	13.0	20.8	7.8	290	1.8	2.9	1.08
200	10.5	16.8	6.3	300	1.6	2.6	0.96

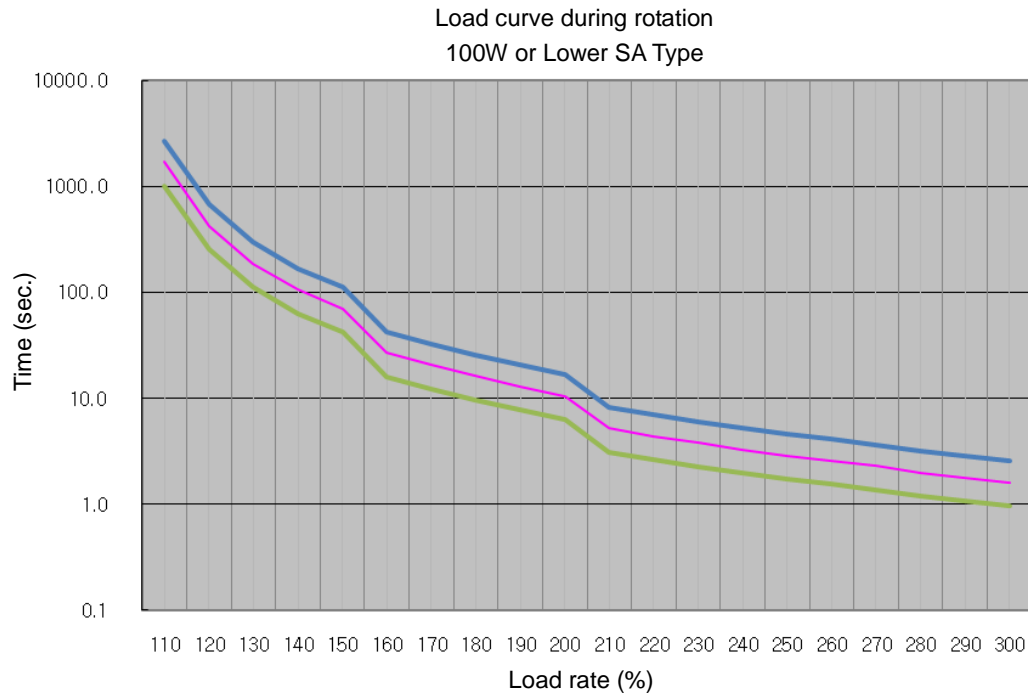

**(2) Stoppage overload graph**

Load (%)	AL-21 Occurring Time (sec)	Max	Min	Load (%)	AL-21 Occurring Time (sec)	Max	Min
100% or less	∞						
110	1372.8	2196.5	823.68	210	3.9	6.2	2.34
120	343.2	549.1	205.92	220	3.4	5.4	2.04
130	152.5	244.0	91.518	230	3.0	4.8	1.8
140	85.8	137.3	51.48	240	2.6	4.2	1.56
150	58.6	93.8	35.16	250	2.3	3.7	1.38
160	16.2	25.9	9.72	260	2.0	3.2	1.2
170	13.0	20.8	7.8	270	1.8	2.9	1.08
180	10.5	16.8	6.3	280	1.6	2.6	0.96
190	8.7	13.9	5.22	290	1.5	2.4	0.9
200	7.2	11.5	4.32	300	1.3	2.1	0.78

Load curve when stopped  
100 W or Lower SA Type

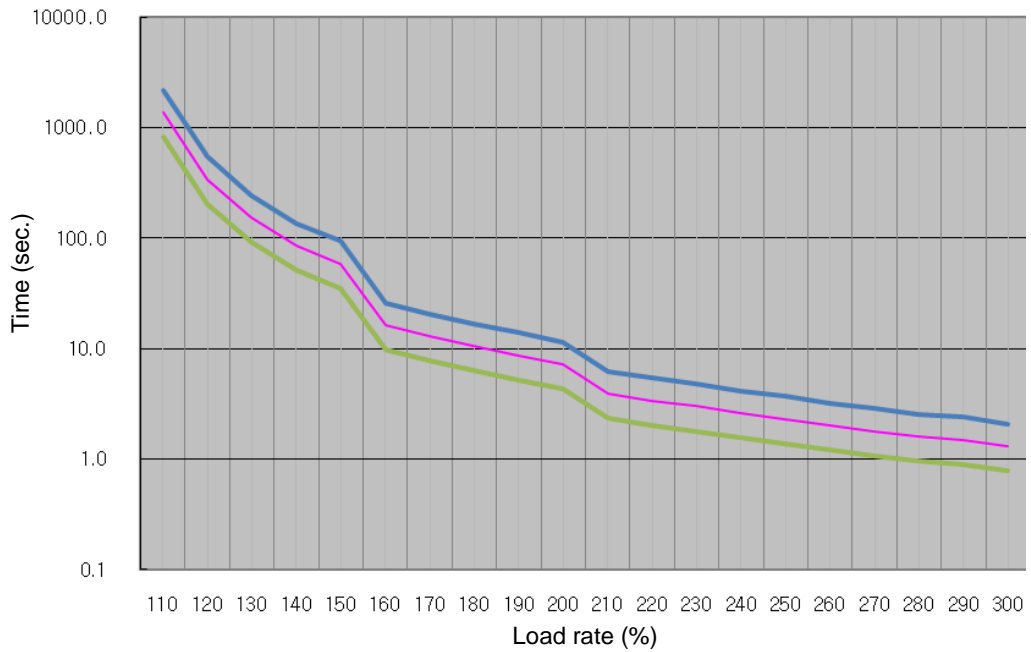

■ Servo Drive Overload Graphs (800 W and 1 KW)

(1) Rotation overload graph

Load (%)	AL-21 Occurring Time (sec)	Max	Min	Load (%)	AL-21 Occurring Time (sec)	Max	Min
100% or less	∞						
110	105800.0	169280.0	63480	210	119.0	190.4	71.4
120	26450.0	42320.0	15870	220	89.2	142.7	53.52
130	11755.0	18808.0	7053	230	49.3	78.9	29.58
140	6612.5	10580.0	3967.5	240	38.8	62.1	23.28
150	2244.0	3590.4	1346.4	250	31.0	49.6	18.6
160	1073.6	1717.8	644.16	260	7.0	11.2	4.2
170	603.2	965.1	361.92	270	6.4	10.2	3.84
180	413.6	661.8	248.16	280	5.7	9.1	3.42
190	273.6	437.8	164.16	290	5.0	8.0	3
200	201.0	321.6	120.6	300	4.6	7.4	2.76

Load curve during rotation

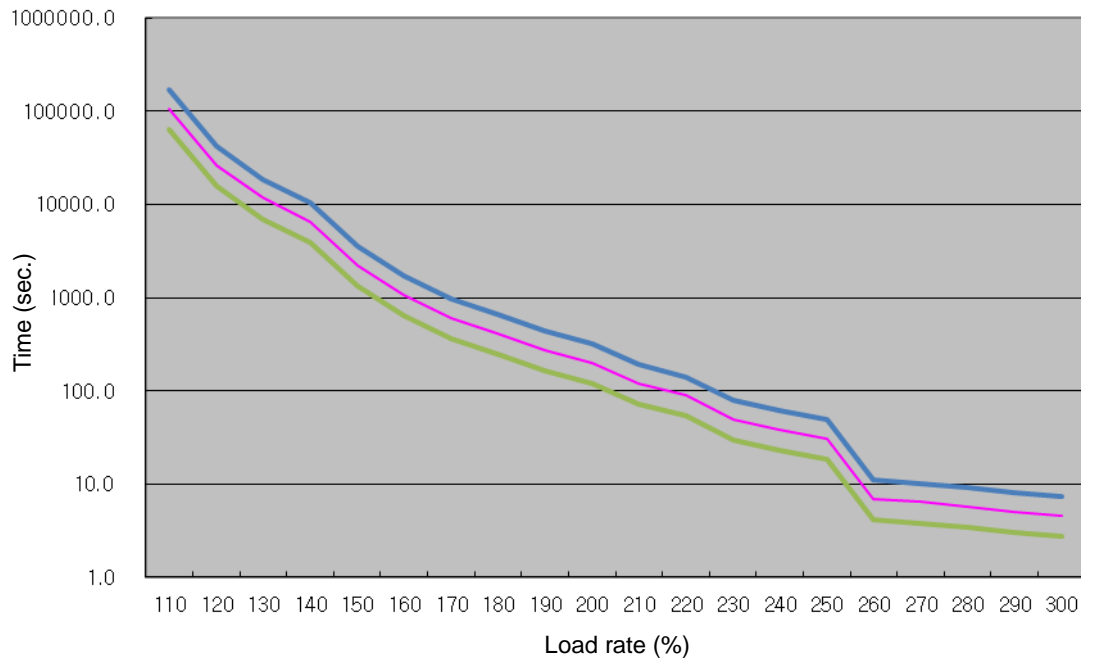

**(2) Stoppage overload graph**

Load (%)	AL-21 Occurring Time (sec)	Max	Min	Load (%)	AL-21 Occurring Time (sec)	Max	Min
100% or less	∞						
110	72512.0	116019.2	43507.2	210	93.4	149.4	56.04
120	18128.0	29004.8	10876.8	220	71.8	114.9	43.08
130	8056.9	12891.0	4834.14	230	53.7	85.9	32.22
140	4532.0	7251.2	2719.2	240	17.2	27.5	10.32
150	1770.0	2832.0	1062	250	14.7	23.5	8.82
160	898.4	1437.4	539.04	260	6.7	10.7	4.02
170	521.8	834.9	313.08	270	6.0	9.6	3.6
180	334.1	534.6	200.46	280	5.7	9.1	3.42
190	226.0	361.6	135.6	290	5.0	8.0	3
200	134.0	214.4	80.4	300	4.6	7.4	2.76

Load curve when stopped

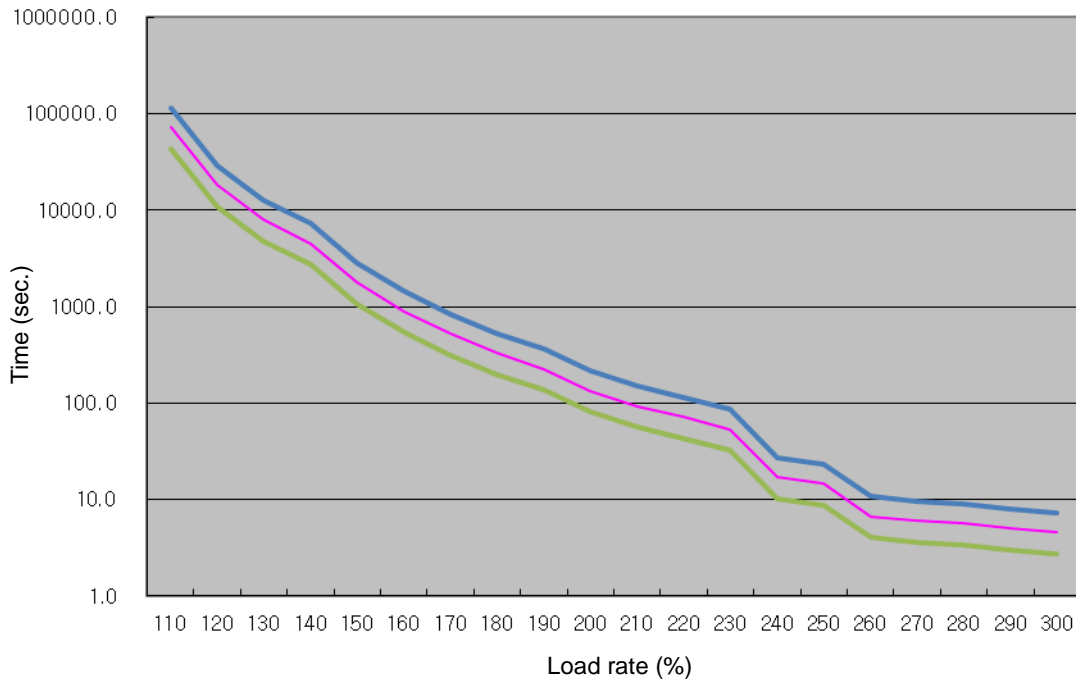

■ Servo Drive Overload Graphs (2 KW and 3.5 KW)

(1) Rotation overload graph

Load (%)	AL-21 Occurring Time (sec)	Max	Min	Load (%)	AL-21 Occurring Time (sec)	Max	Min
100% or less	∞						
110	4832.0	7731.2	2899.2	210	66.8	106.9	40.08
120	1208.0	1932.8	724.8	220	50.1	80.2	30.06
130	536.9	859.0	322.1333	230	38.5	61.6	23.1
140	302.0	483.2	181.2	240	30.3	48.5	18.18
150	257.0	411.2	154.2	250	24.2	38.7	14.52
160	229.0	366.4	137.4	260	4.2	6.7	2.52
170	200.0	320.0	120	270	3.8	6.1	2.28
180	165.0	264.0	99	280	3.4	5.4	2.04
190	131.0	209.6	78.6	290	3.0	4.8	1.8
200	103.0	164.8	61.8	300	2.7	4.3	1.62

Load curve during rotation

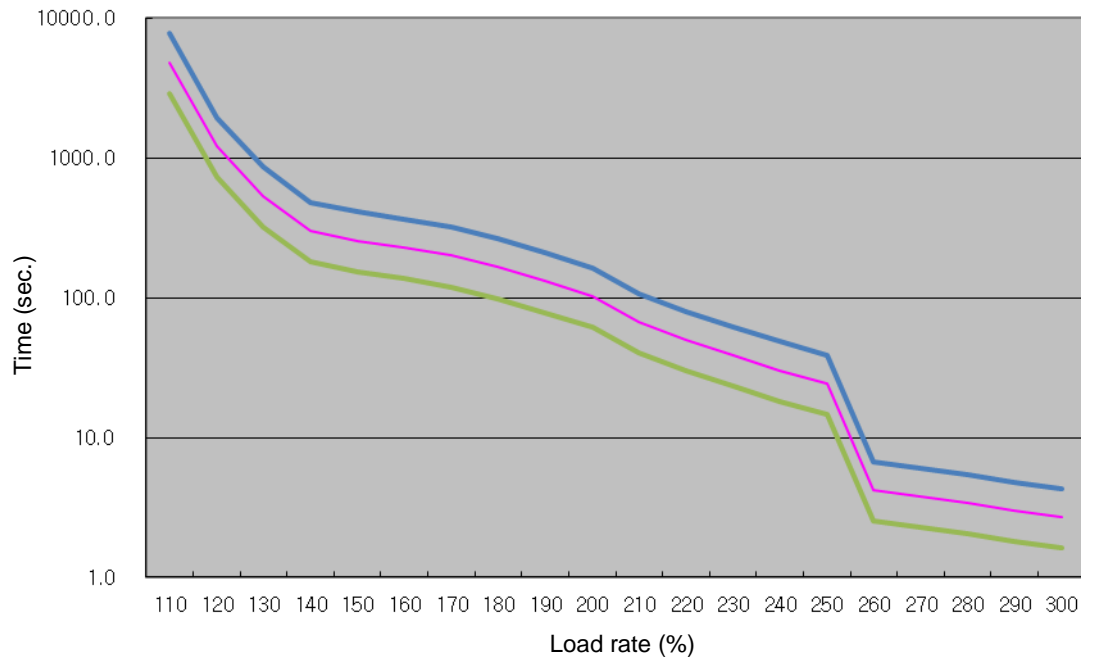

**(2) Stoppage overload graph**

Load (%)	AL-21 Occurring Time (sec)	Max	Min	Load (%)	AL-21 Occurring Time (sec)	Max	Min
100% or less	∞						
110	4832.0	7731.2	2899.2	210	44.0	70.4	26.4
120	1208.0	1932.8	724.8	220	36.0	57.6	21.6
130	536.9	859.0	322.1333	230	30.3	48.5	18.18
140	302.0	483.2	181.2	240	9.7	15.5	5.82
150	154.0	246.4	92.4	250	8.3	13.3	4.98
160	110.0	176.0	66	260	3.8	6.1	2.28
170	90.0	144.0	54	270	3.4	5.4	2.04
180	75.0	120.0	45	280	3.1	5.0	1.86
190	61.0	97.6	36.6	290	2.7	4.3	1.62
200	52.0	83.2	31.2	300	2.5	4.0	1.5

Load curve when stopped

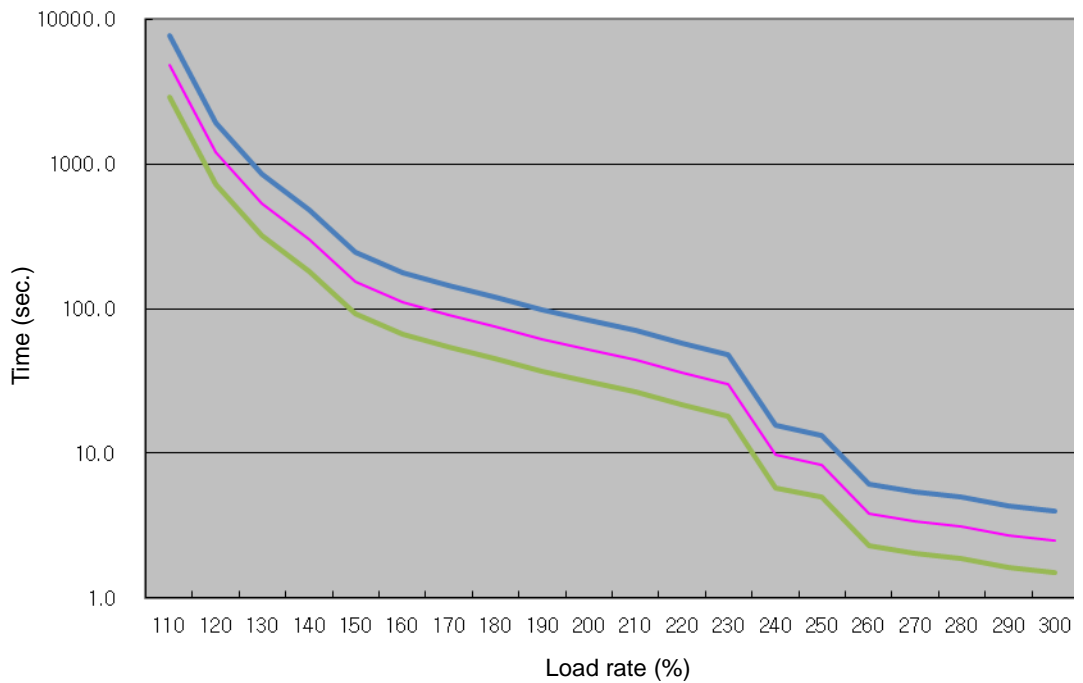

**■ Servo Drive Overload Graphs (5.0KW)**



**(1) Graph of Overload during Rotation**

Load(%)	AL-21 Occurring Time (sec)	MAX	MIN	Load(%)	AL-21 Occurring Time (sec)	MAX	MIN
100% or below	Infinite						
110	4832.0	7731.2	2899.2	210	66.8	106.9	40.08
120	1208.0	1932.8	724.8	220	50.1	80.2	30.06
130	536.9	859.0	322.1333	230	38.5	61.6	23.1
140	302.0	483.2	181.2	240	30.3	48.5	18.18
150	257.0	411.2	154.2	250	24.2	38.7	14.52
160	229.0	366.4	137.4	260	18.0	28.8	10.8
170	200.0	320.0	120	270	16.0	25.6	9.6
180	165.0	264.0	99	280	14.0	22.4	8.4
190	131.0	209.6	78.6	290	8.0	12.8	4.8
200	103.0	164.8	61.8	300	5.0	8.0	3.0

Load Curve During Stop

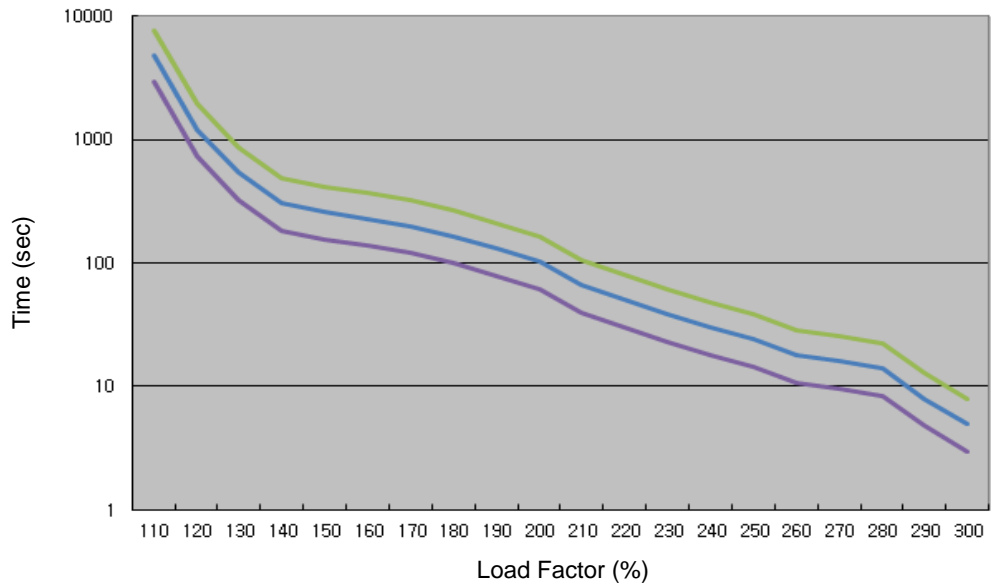

**2) Graph of Overload during Stop**

Load(%)	AL-21 Occurring Time (sec)	MAX	MIN	Load(%)	AL-21 Occurring Time (sec)	MAX	MIN
100% or below	Infinite						
110	4832.0	7731.2	2899.2	210	44.0	70.4	26.4
120	1208.0	1932.8	724.8	220	36.0	57.6	21.6
130	536.9	858.8	322.08	230	30.3	48.5	18.18
140	302.0	483.2	181.2	240	9.7	15.5	5.82
150	154.0	246.4	92.4	250	8.3	13.3	4.98
160	100.0	160.0	60.0	260	3.8	6.1	2.28
170	85.0	136.0	51.0	270	3.4	5.4	2.04
180	70.0	112.0	42.0	280	3.1	5.0	1.86
190	61.0	97.6	36.6	290	2.7	4.3	1.62
200	52.0	83.2	31.2	300	2.5	4.0	1.5

Load Curve During Stop

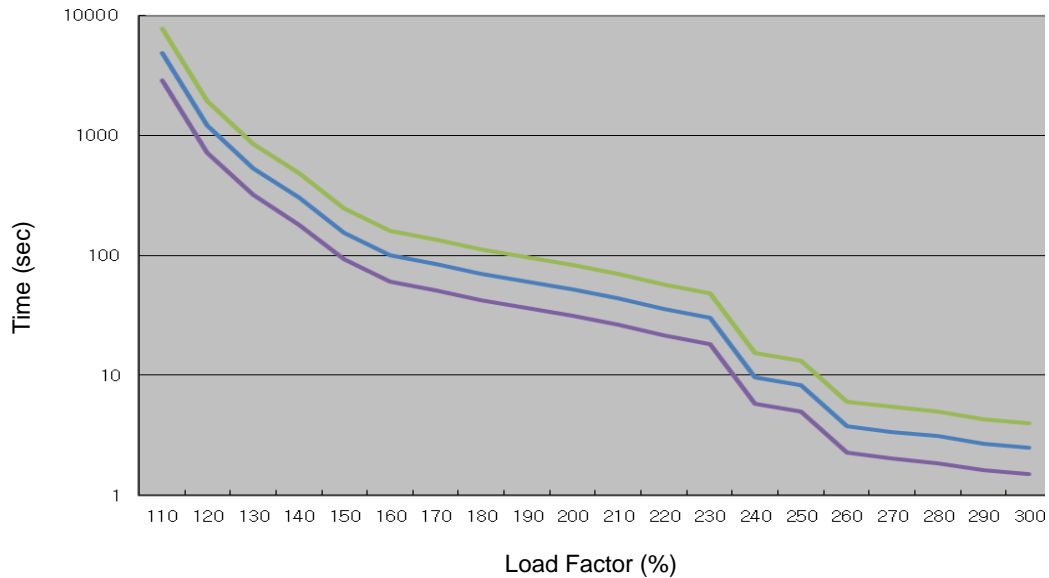





# 12. Appendix

## 12.1 Motor Types and IDs

Model Name	ID	Watt	Notes
SAR3A	1	30	
SAR5A	2	50	
SA01A	3	100	
SA015A	5	150	
SB01A	11	100	
SB02A	12	200	
SB04A	13	400	
HB02A	15	200	Hollow type
HB04A	16	400	Hollow type
SC04A	21	400	
SC06A	22	600	
SC08A	23	800	
SC10A	24	1000	
SC03D	25	300	
SC05D	26	450	
SC06D	27	550	
SC07D	28	650	
SE09A	61	900	
SE15A	62	1500	
SE22A	63	2200	
SE30A	64	3000	
SE06D	65	600	
SE11D	66	1100	
SE16D	67	1600	
SE22D	68	2200	
SE03M	69	300	
SE06M	70	600	
SE09M	71	900	
SE12M	72	1200	
SE05G	73	450	
SE09G	74	850	

Model Name	ID	Watt	Notes
SE13G	75	1300	
SE17G	76	1700	
HE09A	77	900	Hollow type
HE15A	78	1500	Hollow type
SF30A	81	3000	
SF50A	82	5000	
SF22D	85	2200	
LF35D	190	3500	
SF55D	87	5500	
SF75D	88	7500	
SF12M	89	1200	
SF20M	90	2000	
LF30M	192	3000	
SF44M	92	4400	
SF20G	93	1800	
LF30G	191	2900	
SF44G	95	4400	
SF60G	96	6000	
SG22D	111	2200	
LG35D	193	3500	
SG55D	113	5500	
SG75D	114	7500	
SG110D	115	11000	
SG12M	121	1200	
SG20M	122	2000	
LG30M	195	3000	
SG44M	124	4400	
SG60M	125	6000	
SG20G	131	1800	
LG30G	194	2900	
SG44G	133	4400	
SG60G	134	6000	

Model Name	ID	Watt	Notes
SG85G	135	8500	
SG110G	136	11000	
SG150G	137	15000	
FB01A	711	100	
FB02A	712	200	
FB04A	713	400	
FC04A	721	400	
FC06A	722	600	
FC08A	723	800	
FC10A	724	1000	
FC03D	725	300	
FC05D	726	500	
FC06D	727	600	
FC07D	728	700	
FE09A	761	900	
FE15A	762	1500	
FE22A	763	2200	
FE30A	764	3000	
FE06D	765	600	
FE11D	766	1100	
FE16D	767	1600	
FE22D	768	2200	
FE03M	769	300	
FE06M	770	600	
FE09M	771	900	
FE12M	772	1200	
FE05G	773	450	
FE09G	774	850	
FE13G	775	1300	
FE17G	776	1700	

Model Name	ID	Watt	Notes
FF30A	781	3000	
FF50A	782	5000	
FF22D	785	2200	
FF35D	786	3500	
FF55D	787	5500	
FF75D	788	7500	
FF12M	789	1200	
FF20M	790	2000	
FF30M	791	3000	
FF44M	792	4000	
FF20G	793	1800	
FF30G	794	2900	
FF44G	795	4400	
FF60G	796	6000	
FF75G	804	7500	
FG22D	811	2200	
FG35D	812	3500	
FG55D	813	5500	
FG75D	814	7500	
FG12M	821	1200	
FG20M	822	2000	
FG30M	823	3000	
FG44M	824	4400	
FG20G	831	1800	
FG30G	832	2900	



## 12.2 Test Drive Procedure

Thank you for purchasing our product. Perform the following process to conduct the initial test drive:

### Caution

After attaching the servo motor to your equipment, perform the initial operation test and test drive without any load (without any coupling or belt) for safety. Connect the load to the motor for the final test drive.

Order	Details
Product check	<p>Check the name tag to verify that the product received matches the model ordered (refer to section 1.1).</p> <ul style="list-style-type: none"> <li>Check the name tag attached to the right side of the product (to the right side of the shaft on the motor).</li> <li>Main check point: Check the product capacity and options.</li> </ul>
Power connectivity	<p>Wire a single-phase AC 220 V power supply to control power input C1 and C2, and a three-phase AC 220 V power supply to main power input L1, L2, and L3 (refer to section 3.2).</p> <ul style="list-style-type: none"> <li>The product can run on a single-phase AC 220 V power supply, but this reduces torque and the lifespan of the product. Be sure to input a three-phase AC 220 V power supply.</li> </ul>
Signal line wiring	<p>Connect the CN1 (I/O), CN3, CN4, CN5 (communication), CN6 and CN2 encoder cables, and motor power cable based on the operation mode (refer to section 1.2 and chapter 3).</p> <ul style="list-style-type: none"> <li>Always use robot cables if the motor moves.</li> <li>Use twist shield cables for the signal and encoder cables.</li> <li>Tighten the bolts after locking the encoder cable connector (drive direction).</li> <li>Do not modify the U, V, and W wiring of the motor power cable.</li> <li>Do not confuse the CN3 EtherCAT communication port input and the CN4 EtherCAT communication port output cables during wiring.</li> <li>Install a safety jump cable when you are not using a CN6 safety connector.</li> </ul>
Control power on	<p>Supply single-phase AC 220 V power to C1 and C2.</p> <ul style="list-style-type: none"> <li>Check the external input voltage before turning on the servo drive.</li> <li>Check whether the display operates normally (there should not be any broken 7-segments or alarms).</li> </ul>
Main power on	<p>Supply three-phase AC 220 V power to L1, L2, and L3.</p> <ul style="list-style-type: none"> <li>Check the external input voltage before turning on the servo drive.</li> <li>The red charge LED at the bottom of the loader window turns on when the drive receives power.</li> <li>If an alarm appears, it indicates that there is an error in the power circuit, servo motor wiring, or encoder wiring.</li> <li>Turn off the power and fix the error using the information in "Alarm Codes and Descriptions."</li> </ul>
PDO Mapping	<p>Set the PDO mapping. ex) CSP Mode</p> <ul style="list-style-type: none"> <li>Define the Status Word [0x6041], the Position Actual Value [0x6064], and the Mode of Operation [0x6060] in 2nd Transmit PDO mapping.</li> <li>Define the Control Word [0x6040] and the Target Position [0x607A] in 2nd Receive PDO mapping.</li> </ul> <p>※ The content above is the built-in PDO mapping of the L7N. These settings are defined in the EtherCAT Slave Information file (XML file). In addition, the user can change the PDO mapping (however, PDO mapping can be done for up to 8 variables).</p>



Order	Details										
State Machine	Convert the state machine to operational status (refer to section 4.3). <ul style="list-style-type: none"> <li>▪ Perform the conversion in the following order: Init → Pre-Op → Safe-Op → Op.</li> <li>▪ The L/A0 and the L/A1 LEDs blink and the Run LED turns on when the state machine is operational.</li> </ul>										
Check the motor	Read the motor ID [0x2000], the encoder type [0x2001] and the encoder resolution [0x2002] from the EtherCAT master to check whether they match the motor ID and encoder type on the product name plate attached to the right side of the motor.										
Set the control mode	Change the Mode of Operation [0x6060] to CSP. <ul style="list-style-type: none"> <li>▪ Write Dec. 8 in the Mode of Operation [0x6060].</li> </ul> <table border="1" data-bbox="576 600 1431 685"> <tr> <td>0: no mode</td> <td>1: Pp</td> <td>3: Pv</td> <td>4: Tp</td> <td>6: Hm</td> </tr> <tr> <td>7: lp</td> <td>8: Csp</td> <td>9: Csv</td> <td>10: Cst</td> <td></td> </tr> </table>	0: no mode	1: Pp	3: Pv	4: Tp	6: Hm	7: lp	8: Csp	9: Csv	10: Cst	
0: no mode	1: Pp	3: Pv	4: Tp	6: Hm							
7: lp	8: Csp	9: Csv	10: Cst								
Operation 1	Activate the Controlword bit, according to the control mode, to drive the L7N to the target position (refer to section 7.6, "CiA402 Objects").										
Operation 2	11. Adjust the following parameter data to perform the Csv mode operation with the upper level controller. <ul style="list-style-type: none"> <li>▪ Target Velocity: [0x60FF]</li> <li>▪ Velocity Offset: [0x60B1]</li> <li>▪ Torque Offset: [0x60B2]</li> <li>▪ Profile Deceleration Time: [0x6084]</li> <li>▪ Quick Stop Deceleration Time : [0x6085]</li> <li>▪ Velocity Demand Value: [0x606B]</li> <li>▪ Velocity Actual Value: [0x606C]</li> <li>▪ Velocity Window: [0x606D]</li> <li>▪ Velocity Window Time: [0x606E]</li> </ul>										

## Quality Assurance

<b>Product Name</b>	LS Mecapion Servo Drive	<b>Date of Installation</b>	
<b>Model Name</b>	<i>L7 Series</i>	<b>Warranty Period</b>	
<b>Customer</b>	<b>Name</b>		
	<b>Address</b>		
	<b>Phone</b>		
<b>Retailer</b>	<b>Name</b>		
	<b>Address</b>		
	<b>Phone</b>		

This product was produced using strict quality control and testing procedures developed by LS Mecapion technicians.

The warranty applies for 12 months after the date of installation. The warranty is valid for 18 months after the date of manufacture if the installation date is not filled out. However, the term of this warranty may change depending on the terms of the contract.

### Free Technical Support

If the drive malfunctions under proper usage conditions and the product warranty is still valid, contact one of our agencies or designated service centers. We will repair the drive free of charge.

### Paid Technical Support

The warranty does not cover technical support if:

- The malfunction is the result of negligence on the part of the consumer.
- The malfunction is the result of inappropriate voltage or defects in the machines connected to the product.
- The malfunction is the result of an act of god (fire, flood, gas, earthquake, etc.).
- The product was modified or repaired by someone other than our agency or service center.
- The LS Mecapion name tag is not attached to the product.
- The warranty has expired.

※ After installing the servo, fill out this quality assurance form and send it to our quality assurance department (technical support).

Send to: LS Mecapion Quality Assurance Service  
Phone: 053) 593-0066 (154) Fax: 053) 591-8614

Please visit the LS Mecapion Homepage (<http://www.lsmecapion.com>) for more useful information and services.

## User Manual Revision History

Number	Date issued	Revised content	Version number	Notes
1	2012.09.10	Add contents	1.1	
2	2012.11.19	Add Multi turn encoder contents, parameters.	1.2	
3	2013.02.18	Revise product features of servo motor.	1.3	
4	2013.07.20	Added Motor specification sheet and option list. Added AL-35, modified parameter range	1.4	
5	2013.11.07	Added applied condition for Parameter. Added Motor specification sheet and option list.	1.5	
6	2014.03.10	Added option list for motor and drive. Modified parameter range and contents	1.6	
7	2014.07.11	Example of connecting to PLC(PN8B), Added FxL Motor and the contents of 5kW Driver	1.7	

## **Green Management**

LS Mecapion considers protecting the environment a high priority. We work hard to protect the Earth.

The LS Mecapion servo drive is environmentally friendly.

You can disassemble the drive and recycle the iron, aluminum, bronze, and synthetic resin (cover) components.

