

## Ordering Code



APEX DYNAMICS, INC.

### AB Series

**AB090** - **010** - **S1** - **P1** / **MOTOR**

**Gearbox Size:**

AB042, AB060, AB060A, AB090, AB090A  
AB115, AB142, AB180, AB220

**Shaft Option:**

S1: Smooth Output Shaft  
S2: Output Shaft with Key

**Motor Designation:**

Manufacturer Type  
And Model

**Ratio:**

1 Stage: 3, 4, 5, 6, 7, 8, 9, 10  
2 Stage: 15, 20, 25, 30, 35, 40, 45, 50, 60, 70,  
80, 90, 100

**Backlash:**

P0: Micro Backlash  
P1: Reduced Backlash  
P2: Standard Backlash

**Ordering Example: AB090-010-S1-P1 / SIEMENS 1FT6 041-4AF71**

### ABR Series

**ABR090** - **010** - **S1** - **P1** / **MOTOR**

**Gearbox Size:**

ABR042, ABR060, ABR090  
ABR115, ABR142, ABR180,  
ABR220

**Shaft Option:**

S1: Smooth Output Shaft  
S2: Output Shaft with Key

**Motor Designation:**

Manufacturer Type  
And Model

**Ratio:**

1 Stage: 3, 4, 5, 6, 7, 8, 9, 10, 14, 20  
2 Stage: 15, 20, 25, 30, 35, 40, 45, 50, 60, 70,  
80, 90, 100, 120, 140, 160, 180, 200

**Backlash:**

P0: Micro Backlash  
P1: Reduced Backlash  
P2: Standard Backlash

**Ordering Example: ABR090-010-S1-P1 / SIEMENS 1FT6 041-4AF71**

■ Please visit our website for newest update data.



APEX DYNAMICS, INC.

No. 6, 20th Rd., Taichung Industrial Park, Taichung, Taiwan, R.O.C.

Tel: 886 4 23550219 / Fax: 886 4 23550218

E-mail: sales@apexdyna.com

Website: www.apexdyna.com

APEX-2007-07-AB / ABA / ABR-2.0E-2.0V

# AB / ABR Series

## HIGH PRECISION PLANETARY GEARBOXES

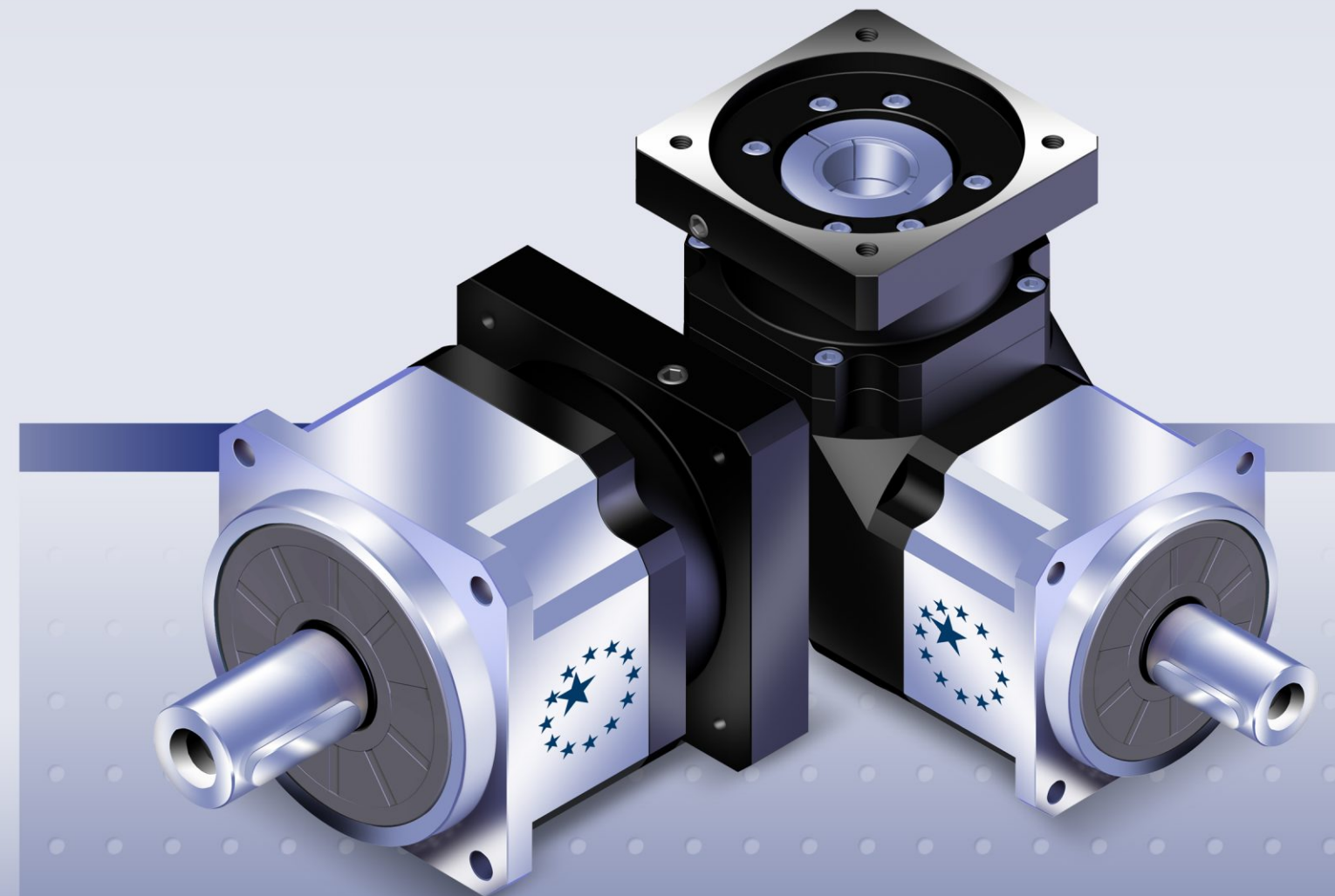

# Stainless



# AB / ABR Series

## Characteristic Highlights



Equipped with **solid uncaged needle roller bearings**, provides maximum contact points to increase stiffness and generates high output torque.

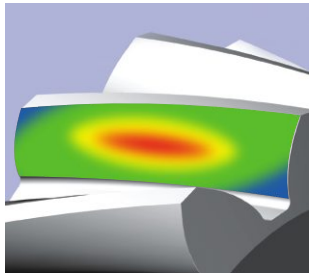

A high setting gear performance is achieved by using our **HeliTopo technology**. This **eases off the tooth profile** and **crowns the lead of each tooth**. This optimizes the gear mesh alignment and overlap to achieve maximum tooth surface contact.

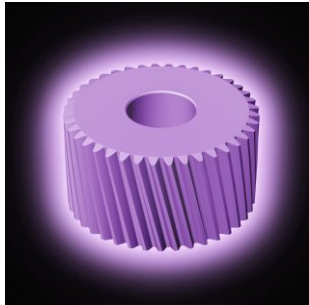

Our **in house plasma nitriding** heat treatment process maintains the tooth surface hardness at **840Hv** for superior wear-resistance and a core hardness at **30 HRC** for toughness.

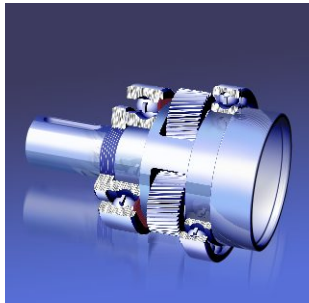

**One piece planet carrier with extended bearing design** provides maximum radial load capacity and increases system reliability and stiffness.



**True Helical Gear Design**  
Precision helical gearing increases tooth to tooth contact ratio by over 33% vs spur gearing. The helix angle produces smooth and quiet operation with decreased backlash (less than 1 arc-minutes and  $\leq 56\text{dB}$ ).



**Patented planet carrier design** puts the sun gear bearing directly into the planet carrier. It minimizes gear misalignment to gain higher accuracy.

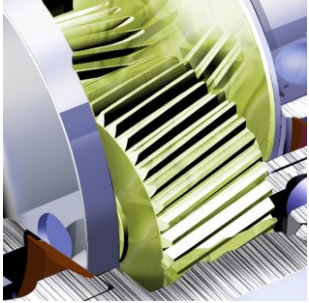

**Triple split collet with dynamic balanced set collar clamping system** provides backlash free power transmission and eliminates slippage. 100% concentricity allows for smooth rotation and higher input speed capability.

Lubricated with **Nyogel 792D** synthetic grease (Smart Grease) and sealed to **IP65** standards prevents leakage and is maintenance free.

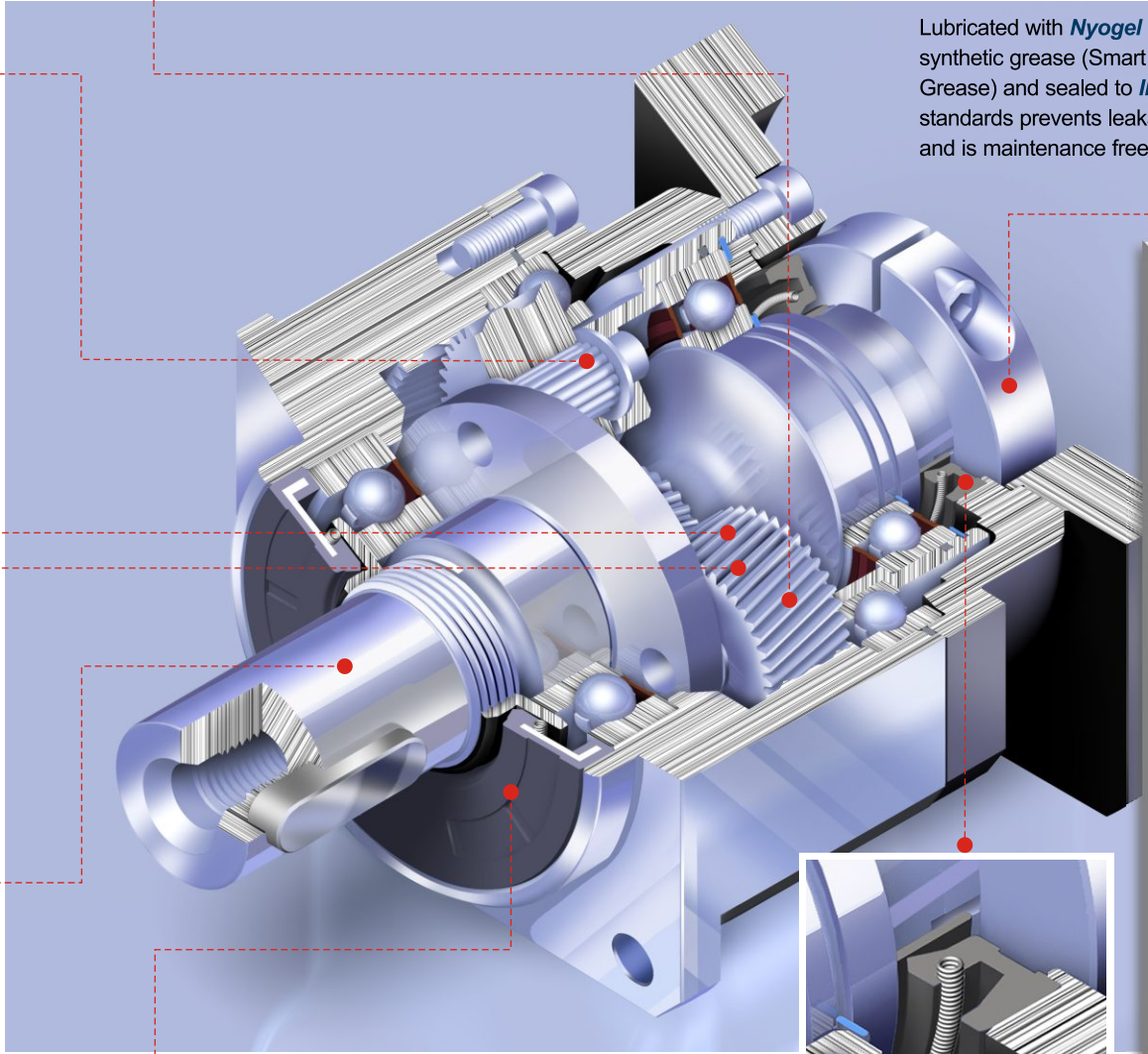

**NEW - Patented output sealing systems design** eliminates friction and heat generation which is accomplished by applying our hi-tech coating to all output contact surfaces. This coating reaches a hardness of **3700Hv** and is ground to  $R_a 0.2 \mu\text{m}$  finish to ensure sealing.

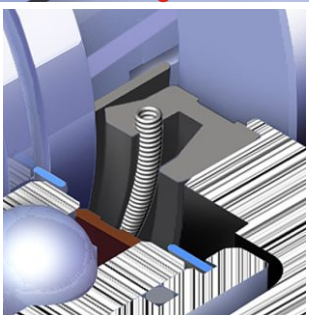

**NEW - Patented input sealing system design** eliminates break away torque and decreases friction/heat. The hi-tech coating bushing (**3700 Hv**,  $R_a 0.2 \mu\text{m}$  finish) interfaces with our proprietary seal which decreases wear and erosion of both sealing surfaces. This new patent prevents leakage and has a service life of over 20,000 hours.

## ABR Series

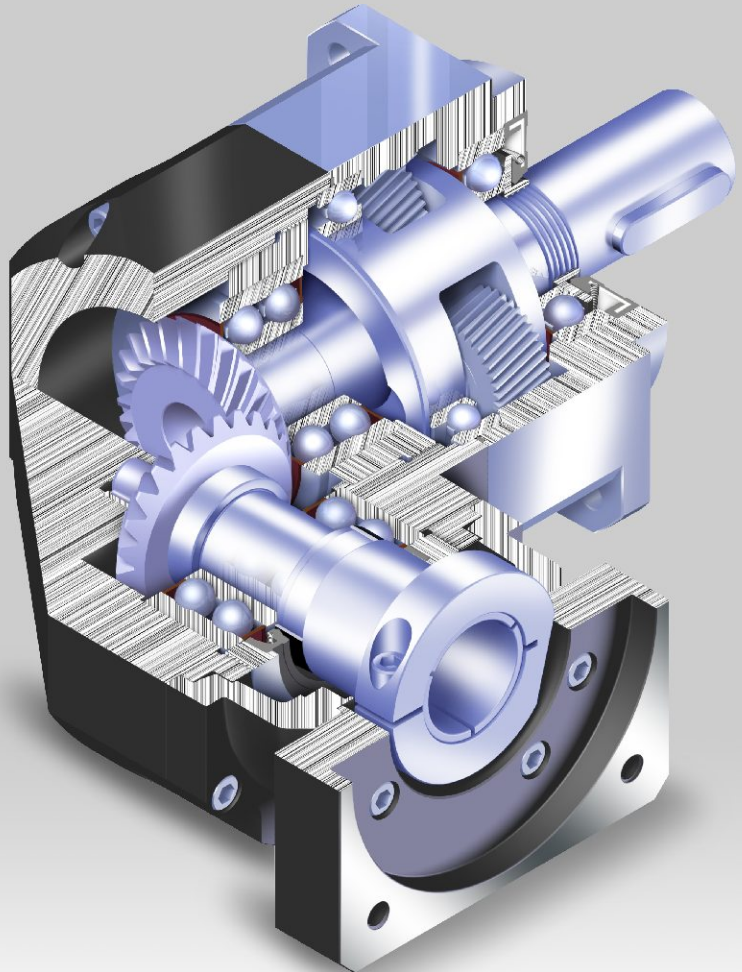

**ABR version** with 90° input via helical bevel gear. Featuring an extremely short, light yet rigid housing and full compatibility with standard motor adapters.



# AB Series Specifications

## Dimensions (1-stage, Ratio i=3~10)

### Gearbox Performance

Model No.	Stage	Ratio	AB042	AB060	AB060A	AB090	AB090A	AB115	AB142	AB180	AB220	
Nominal Output Torque $T_{2N}$	1	3	20	55	-	130	-	208	342	588	1,140	
		4	19	50	-	140	-	290	542	1,050	1,700	
		5	22	60	-	160	-	330	650	1,200	2,000	
		6	20	55	-	150	-	310	600	1,100	1,900	
		7	19	50	-	140	-	300	550	1,100	1,800	
		8	17	45	-	120	-	260	500	1,000	1,600	
		9	14	40	-	100	-	230	450	900	1,500	
		10	14	40	-	100	-	230	450	900	1,500	
		2	15	20	55	55	130	130	208	342	588	1,140
			20	19	50	50	140	140	290	542	1,050	1,700
	25		22	60	60	160	160	330	650	1,200	2,000	
	30		20	55	55	150	150	310	600	1,100	1,900	
	35		19	50	50	140	140	300	550	1,100	1,800	
	40		17	45	45	120	120	260	500	1,000	1,600	
	45		14	40	40	100	100	230	450	900	1,500	
	50		22	60	60	160	160	330	650	1,200	2,000	
	60		20	55	55	150	150	310	600	1,100	1,900	
	70		19	50	50	140	140	300	550	1,100	1,800	
	80	17	45	45	120	120	260	500	1,000	1,600		
	90	14	40	40	100	100	230	450	900	1,500		
100	14	40	40	100	100	230	450	900	1,500			
Max. Output Torque $T_{2B}$	Nm	1,2	3 times of Nominal Output Torque									
Nominal Input Speed $n_{1N}$	rpm	1,2	5,000 5,000 5,000 4,000 4,000 4,000 3,000 3,000 2,000									
Max. Input Speed $n_{1B}$	rpm	1,2	10,000 10,000 10,000 8,000 8,000 8,000 6,000 6,000 4,000									
Micro Backlash $P_0$	arcmin	1	3~10									
Reduced Backlash $P_1$	arcmin	1	3~10									
		2	15~100									
Standard Backlash $P_2$	arcmin	1	3~10									
		2	15~100									
Torsional Rigidity	Nm/arcmin	1,2	3~100									
Max. Radial Load $F_{2R}^2$	N	1,2	3~100									
Max. Axial Load $F_{2A1B}^2$	N	1,2	3~100									
Max. Axial Load $F_{2A2B}^2$	N	1,2	3~100									
Service Life	hr	1,2	3~100									
Efficiency $\eta$	%	1	3~10									
		2	15~100									
Weight	kg	1	3~10									
		2	15~100									
Operating Temp	°C	1,2	3~100									
Lubrication		1,2	3~100									
Degree of Gearbox Protection		1,2	3~100									
Mounting Position		1,2	3~100									
Noise Level ( $n_1=3000$ rpm)	dB	1,2	3~100									

### Gearbox Inertia

Model No.	Stage	Ratio	AB042	AB060	AB060A	AB090	AB090A	AB115	AB142	AB180	AB220	
Mass Moments of Inertia $J_1$	1	3	0.03	0.16	-	0.61	-	3.25	9.21	28.98	69.61	
		4	0.03	0.14	-	0.48	-	2.74	7.54	23.67	54.37	
		5	0.03	0.13	-	0.47	-	2.71	7.42	23.29	53.27	
		6	0.03	0.13	-	0.45	-	2.65	7.25	22.75	51.72	
		7	0.03	0.13	-	0.45	-	2.62	7.14	22.48	50.97	
		8	0.03	0.13	-	0.44	-	2.58	7.07	22.59	50.84	
		9	0.03	0.13	-	0.44	-	2.57	7.04	22.53	50.63	
		10	0.03	0.13	-	0.44	-	2.57	7.03	22.51	50.56	
		2	15	0.03	0.03	0.13	0.13	0.47	0.47	2.71	7.42	23.29
			20	0.03	0.03	0.13	0.13	0.47	0.47	2.71	7.42	23.29
	25		0.03	0.03	0.13	0.13	0.47	0.47	2.71	7.42	23.29	
	30		0.03	0.03	0.13	0.13	0.47	0.47	2.71	7.42	23.29	
	35		0.03	0.03	0.13	0.13	0.47	0.47	2.71	7.42	23.29	
	40		0.03	0.03	0.13	0.13	0.47	0.47	2.71	7.42	23.29	
	45		0.03	0.03	0.13	0.13	0.47	0.47	2.71	7.42	23.29	
	50		0.03	0.03	0.13	0.13	0.44	0.44	2.57	7.03	22.51	
	60		0.03	0.03	0.13	0.13	0.44	0.44	2.57	7.03	22.51	
	70		0.03	0.03	0.13	0.13	0.44	0.44	2.57	7.03	22.51	
	80	0.03	0.03	0.13	0.13	0.44	0.44	2.57	7.03	22.51		
	90	0.03	0.03	0.13	0.13	0.44	0.44	2.57	7.03	22.51		
100	0.03	0.03	0.13	0.13	0.44	0.44	2.57	7.03	22.51			

1. Ratio ( $i=N_{in}/N_{out}$ )

\* S1 service life 10,000 hrs

2. Applied to the output shaft center @ 100 rpm

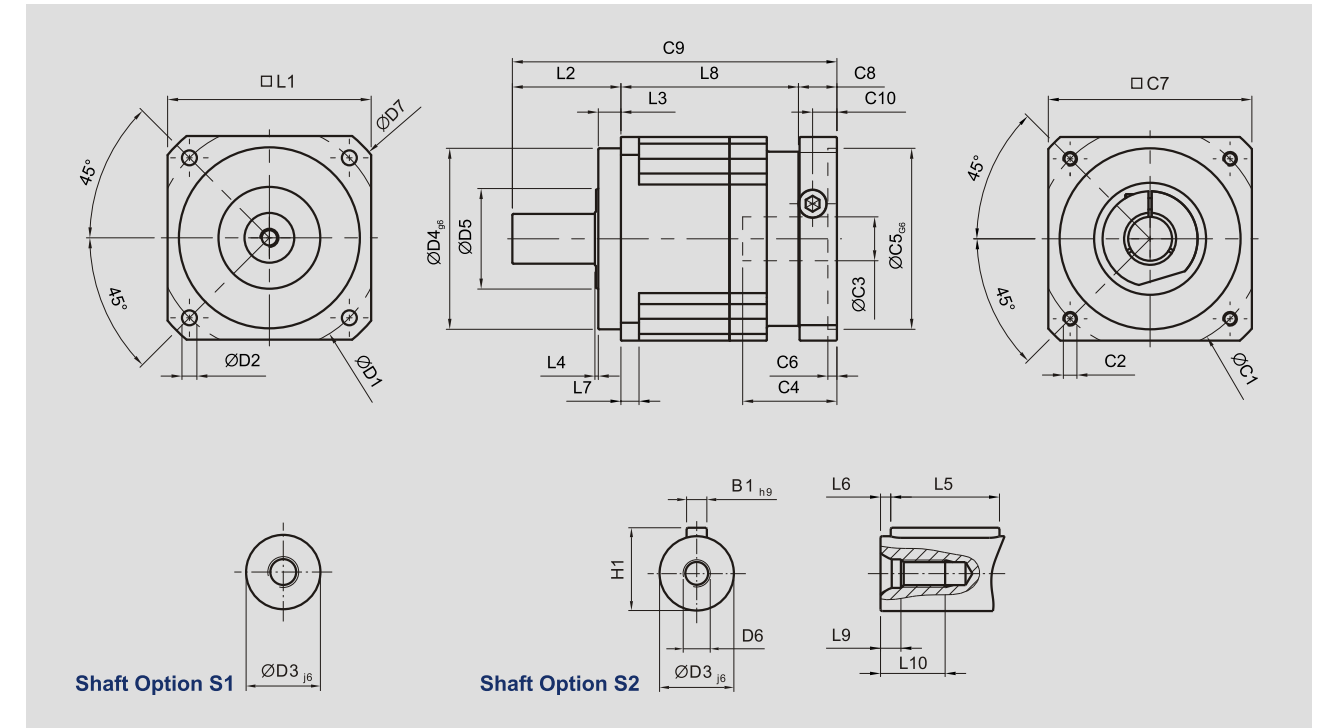

[unit: mm]

Dimension	AB042	AB060	AB090	AB115	AB142	AB180	AB220
D1	50	70	100	130	165	215	250
D2	3.4	5.5	6.6	9	11	13	17
D3 <sub>j6</sub>	13	16	22	32	40	55	75
D4 <sub>g6</sub>	35	50	80	110	130	160	180
D5	22	45	65	95	75	95	115
D6	M4 x 0.7P	M5 x 0.8P	M8 x 1.25P	M12 x 1.75P	M16 x 2P	M20 x 2.5P	M20 x 2.5P
D7	56	80	116	152	185	240	292
L1	42	60	90	115	142	180	220
L2	26	37	48	65	97	105	138
L3	5.5	7	10	12	15	20	30
L4	1	1.5	1.5	2	3	3	3
L5	16	25	32	40	63	70	90
L6	2	2	3	5	5	6	7
L7	4	6	8	10	12	15	20
L8	31	61	78.5	102	119.5	154	163.5
L9	4.5	4.8	7.2	10	12	15	15
L10	10	12.5	19	28	36	42	42
C1 <sup>3</sup>	46	70	100	130	165	215	235
C2 <sup>3</sup>	M4 x 0.7P	M5 x 0.8P	M6 x 1P	M8 x 1.25P	M10 x 1.5P	M12 x 1.75P	M12 x 1.75P
C3 <sup>3</sup>	≤11	*≤14 / ≤16	≤19 / ≤24	≤32	≤38	≤48	≤55
C4 <sup>3</sup>	25	34	40	50	60	85	116
C5 <sup>3</sup> <sub>G6</sub>	30	50	80	110	130	180	200
C6 <sup>3</sup>	3.5	8	4	5	6	6	6
C7 <sup>3</sup>	42	60	90	115	142	190	220
C8 <sup>3</sup>	29.5	19	17	19.5	22.5	29	63
C9 <sup>3</sup>	86.5	117	143.5	186.5	239	288	364.5
C10 <sup>3</sup>	8.75	13.5	10.75	13	15	20.75	53
B1 <sub>h9</sub>	5	5	6	10	12	16	20
H1	15	18	24.5	35	43	59	79.5

3. C1~C10 are motor specific dimensions (metric std shown). Refer to Apexdyna.com and Design Tool to view your specific motor mounting system.  
\* AB060 ratio 5, 10 offers C3 ≤ 16 option.

# AB Series

Dimensions (2-stage, Ratio i=15~100)

# ABR Series

Specifications

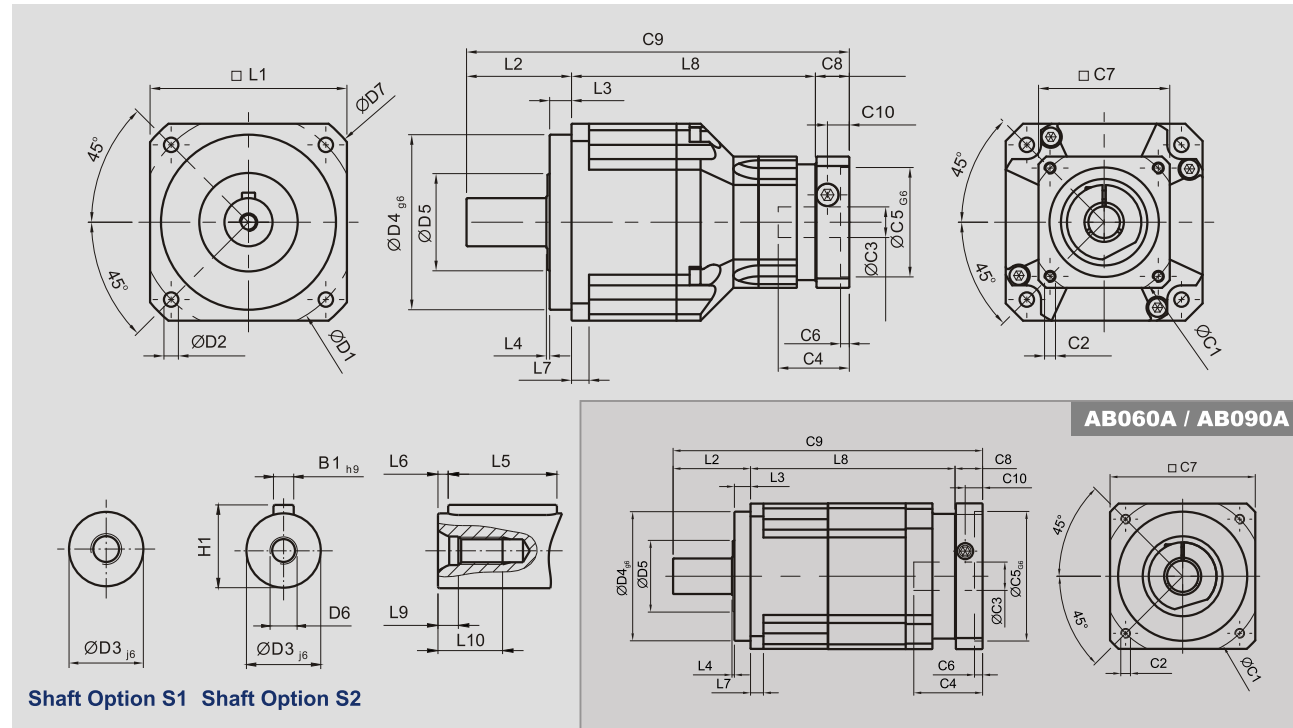

[unit: mm]

Dimension	AB042	AB060	AB060A	AB090	AB090A	AB115	AB142	AB180	AB220
D1	50	70		100		130	165	215	250
D2	3.4	5.5		6.6		9	11	13	17
D3 <sub>j6</sub>	13	16		22		32	40	55	75
D4 <sub>g6</sub>	35	50		80		110	130	160	180
D5	22	45		65		95	75	95	115
D6	M4 x 0.7P	M5 x 0.8P		M8 x 1.25P		M12 x 1.75P	M16 x 2P	M20 x 2.5P	M20 x 2.5P
D7	56	80		116		152	185	240	292
L1	42	60		90		115	142	180	220
L2	26	37		48		65	97	105	138
L3	5.5	7		10		12	15	20	30
L4	1	1.5		1.5		2	3	3	3
L5	16	25		32		40	63	70	90
L6	2	2		3		5	5	6	7
L7	4	6		8		10	12	15	20
L8	58.5	72	98	111.5	126.5	143.5	176	209.5	248
L9	4.5	4.8		7.2		10	12	15	15
L10	10	12.5		19		28	36	42	42
C1 <sup>4</sup>	46	46	70	70	100	100	130	165	215
C2 <sup>4</sup>	M4 x 0.7P	M4 x 0.7P	M5 x 0.8P	M5 x 0.8P	M6 x 1P	M6 x 1P	M8 x 1.25P	M10 x 1.5P	M12 x 1.75P
C3 <sup>4</sup>	≤11	*≤11 / ≤12	≤14 / ≤16	*≤14 / ≤15.875 / ≤16	≤19 / ≤24	≤19 / ≤24	≤32	≤38	≤48
C4 <sup>4</sup>	25	25	34	34	40	40	50	60	85
C5 <sup>4</sup> <sub>G6</sub>	30	30	50	50	80	80	110	130	180
C6 <sup>4</sup>	3.5	3.5	8	8	4	4	5	6	6
C7 <sup>4</sup>	42	42	60	60	90	90	115	142	190
C8 <sup>4</sup>	29.5	29.5	19	19	17	17	19.5	22.5	29
C9 <sup>4</sup>	114	138.5	154	178.5	191.5	225.5	292.5	337	415
C10 <sup>4</sup>	8.75	8.75	13.5	13.5	10.75	10.75	13	15	20.75
B1 <sub>h9</sub>	5	5		6		10	12	16	20
H1	15	18		24.5		35	43	59	79.5

4. C1~C10 are motor specific dimensions (metric std shown). Refer to Apexdyna.com and Design Tool to view your specific motor mounting system.  
\*AB060 ratio 15~50 offers C3 ≤ 12 option. \*AB090 ratio 15~50 offers C3 ≤ 15.875 / ≤ 16 option.

## Gearbox Performance

Model No.	Stage	Ratio	ABR042	ABR060	ABR090	ABR115	ABR142	ABR180	ABR220	
Nominal Output Torque T <sub>2N</sub>	1	3	9	36	90	195	342	588	1,140	
		4	12	48	120	260	520	1,040	1,680	
		5	15	60	150	325	650	1,200	2,000	
		6	18	55	150	310	600	1,100	1,900	
		7	19	50	140	300	550	1,100	1,800	
		8	17	45	120	260	500	1,000	1,600	
		9	14	40	100	230	450	900	1,500	
		10	14	40	100	230	450	900	1,500	
		14	-	42	140	300	550	1,100	1,800	
		20	-	40	100	230	450	900	1,500	
	2	15	14	-	-	-	-	-	-	
		20	14	-	-	-	-	-	-	
		25	15	60	150	325	650	1,200	2,000	
		30	20	55	150	310	600	1,100	1,900	
		35	19	50	140	300	550	1,100	1,800	
		40	17	45	120	260	500	1,000	1,600	
		45	14	40	100	230	450	900	1,500	
		50	14	60	100	230	650	1,200	2,000	
		60	20	55	150	310	600	1,100	1,900	
		70	19	50	140	300	550	1,100	1,800	
80	17	45	120	260	500	1,000	1,600			
90	14	40	100	230	450	900	1,500			
100	14	40	100	230	450	900	1,500			
120	-	-	150	310	600	1,100	1,900			
140	-	-	140	300	550	1,100	1,800			
160	-	-	120	260	550	1,000	1,600			
180	-	-	100	230	450	900	1,500			
200	-	-	100	230	450	900	1,500			
Max. Output Torque T <sub>2B</sub>	Nm	1,2	3~200	3 times of Nominal Output Torque						
Nominal Input Speed n <sub>1N</sub>	rpm	1,2	3~200	5,000	5,000	4,000	4,000	3,000	3,000	2,000
Max. Input Speed n <sub>1B</sub>	rpm	1,2	3~200	10,000	10,000	8,000	8,000	6,000	6,000	4,000
Micro Backlash P0	arcmin	1	3~20	-	-	≤2	≤2	≤2	≤2	≤2
		2	25~200	-	-	≤4	≤4	≤4	≤4	≤4
Reduced Backlash P1	arcmin	1	3~20	≤4	≤4	≤4	≤4	≤4	≤4	≤4
		2	25~200	≤7	≤7	≤7	≤7	≤7	≤7	≤7
Standard Backlash P2	arcmin	1	3~20	≤6	≤6	≤6	≤6	≤6	≤6	≤6
		2	25~200	≤9	≤9	≤9	≤9	≤9	≤9	≤9
Torsional Rigidity	Nm/arcmin	1,2	3~200	3	7	14	25	50	145	225
Max. Radial Load F <sub>2rB</sub> <sup>2</sup>	N	1,2	3~200	780	1,530	3,250	6,700	9,400	14,500	50,000
Max. Axial Load F <sub>2a1B</sub> <sup>2</sup>	N	1,2	3~200	350	630	1,300	3,000	4,000	6,200	35,000
Max. Axial Load F <sub>2a2B</sub> <sup>2</sup>	N	1,2	3~200	390	765	1,625	3,350	4,700	7,250	25,000
Service Life	hr	1,2	3~200	20,000*						
Efficiency η	%	1	3~20	≥95%						
		2	25~200	≥92%						
Weight	kg	1	3~20	0.9	2.1	6.4	13	24.5	51	83
		2	25~200	1.2	1.5	7.8	14.2	27.5	54	95
Operating Temp	°C	1,2	3~200	-10°C~+90°C						
Lubrication		1,2	3~200	synthetic gear grease (NYOGEL 792D)						
Degree of Gearbox Protection		1,2	3~200	IP65						
Mounting Position		1,2	3~200	all directions						
Noise Level (n=3000rpm)	dB	1,2	3~200	≤61	≤63	≤65	≤68	≤70	≤72	≤74

## Gearbox Inertia

Model No.	Stage	Ratio	ABR042	ABR060	ABR090	ABR115	ABR142	ABR180	ABR220
Mass Moments of Inertia J <sub>i</sub>	1	3~10	0.09	0.35	2.25	6.84	23.4	68.9	135.4
		14	-	0.07	1.87	6.25	21.8	65.6	119.8
		20	-	0.07	1.87	6.25	21.8	65.6	119.8
	2	15	0.09	-	-	-	-	-	-
		20	0.09	-	-	-	-	-	-
		25~100	0.09	0.09	0.35	2.25	6.84	23.4	68.9
120~200	-	-	0.31	1.87	6.25	21.8	65.6		

1. Ratio (i=N<sub>in</sub>/N<sub>out</sub>)

\*S1 service life 10,000 hrs

2. Applied to the output shaft center @ 100 rpm

# ABR Series

Dimensions (1-stage, Ratio  $i=3\sim 20$ )

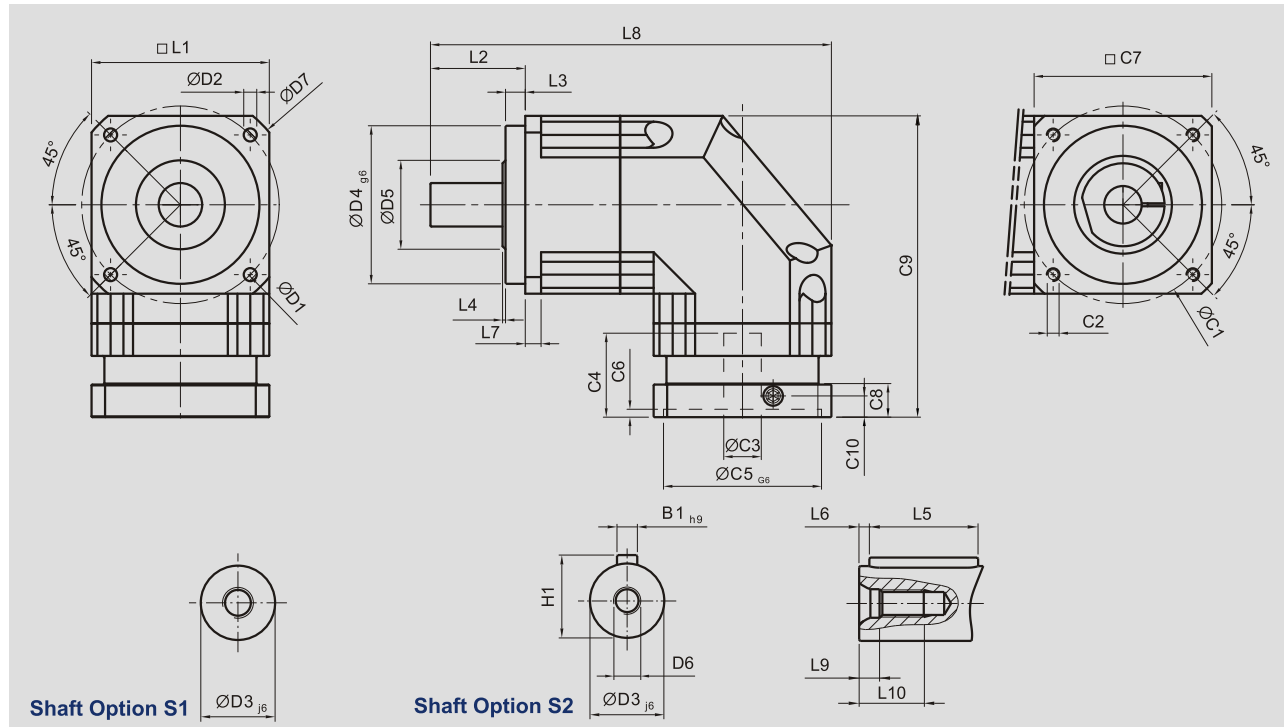

[unit: mm]

Dimension	ABR042	ABR060	ABR090	ABR115	ABR142	ABR180	ABR220
D1	50	70	100	130	165	215	250
D2	3.4	5.5	6.6	9	11	13	17
D3 <sub>j6</sub>	13	16	22	32	40	55	75
D4 <sub>g6</sub>	35	50	80	110	130	160	180
D5	22	45	65	95	75	95	115
D6	M4 x 0.7P	M5 x 0.8P	M8 x 1.25P	M12 x 1.75P	M16 x 2P	M20 x 2.5P	M20 x 2.5P
D7	56	80	116	152	185	240	292
L1	42	60	90	115	142	180	220
L2	26	37	48	65	97	105	138
L3	5.5	7	10	12	15	20	30
L4	1	1.5	1.5	2	3	3	3
L5	16	25	32	40	63	70	90
L6	2	2	3	5	5	6	7
L7	4	6	8	10	12	15	20
L8	111.5	145	203	259	333	394	484
L9	4.5	4.8	7.2	10	12	15	15
L10	10	12.5	19	28	36	42	42
C1 <sup>3</sup>	46	70	100	130	165	215	235
C2 <sup>3</sup>	M4 x 0.7P	M5 x 0.8P	M6 x 1P	M8 x 1.25P	M10 x 1.5P	M12 x 1.75P	M12 x 1.75P
C3 <sup>3</sup>	≤11	≤14 / ≤16	≤19 / ≤24	≤32	≤38	≤48	≤55
C4 <sup>3</sup>	25	34	40	50	60	85	116
C5 <sup>3</sup> <sub>G6</sub>	30	50	80	110	130	180	200
C6 <sup>3</sup>	3.5	8	4	5	6	6	6
C7 <sup>3</sup>	42	60	90	115	142	190	220
C8 <sup>3</sup>	29.5	19	17	19.5	22.5	29	63
C9 <sup>3</sup>	90.5	111.5	152.5	191.5	235.5	303.5	378.5
C10 <sup>3</sup>	8.75	13.5	10.75	13	15	20.75	53
B1 <sub>h9</sub>	5	5	6	10	12	16	20
H1	15	18	24.5	35	43	59	79.5

3. C1-C10 are motor specific dimensions (metric std shown). Refer to Apexdyna.com and Design Tool to view your specific motor mounting system.

Dimensions (2-stage, Ratio  $i=15\sim 200$ )

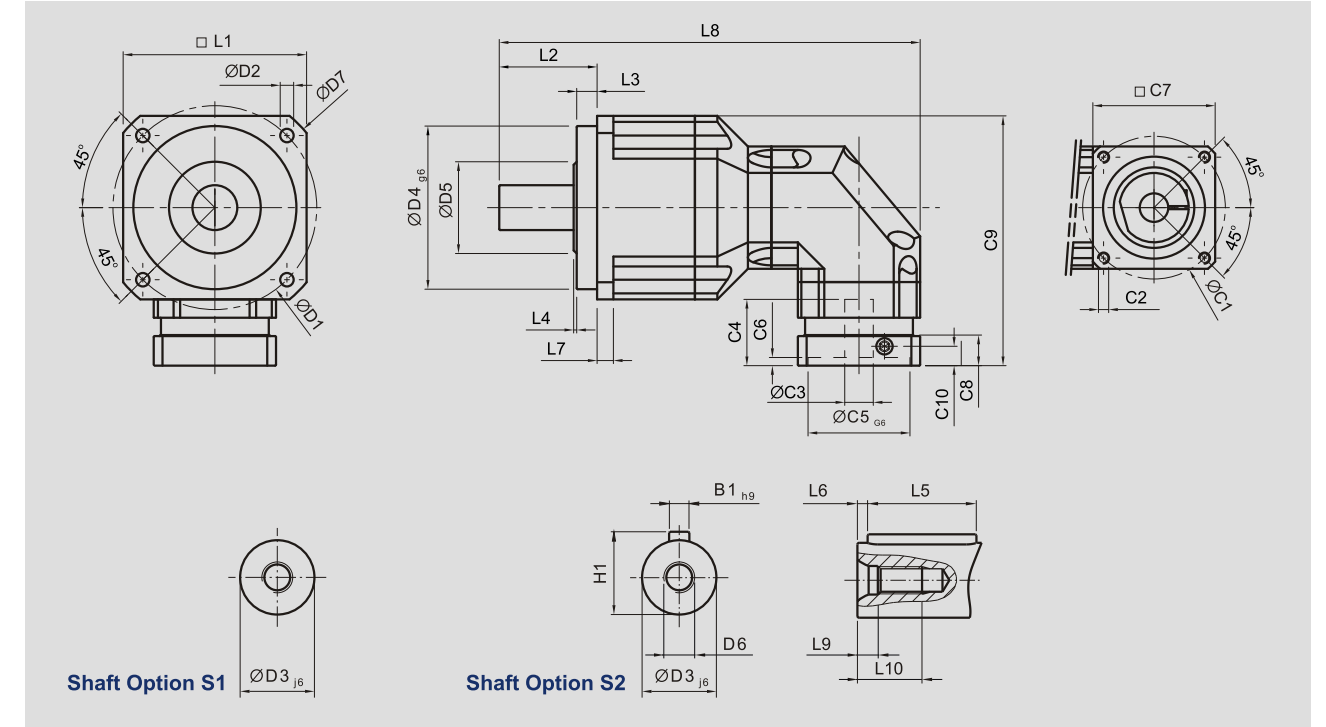

[unit: mm]

Dimension	ABR042	ABR060	ABR090	ABR115	ABR142	ABR180	ABR220
D1	50	70	100	130	165	215	250
D2	3.4	5.5	6.6	9	11	13	17
D3 <sub>j6</sub>	13	16	22	32	40	55	75
D4 <sub>g6</sub>	35	50	80	110	130	160	180
D5	22	45	65	95	75	95	115
D6	M4 x 0.7P	M5 x 0.8P	M8 x 1.25P	M12 x 1.75P	M16 x 2P	M20 x 2.5P	M20 x 2.5P
D7	56	80	116	152	185	240	292
L1	42	60	90	115	142	180	220
L2	26	37	48	65	97	105	138
L3	5.5	7	10	12	15	20	30
L4	1	1.5	1.5	2	3	3	3
L5	16	25	32	40	63	70	90
L6	2	2	3	5	5	6	7
L7	4	6	8	10	12	15	20
L8	139	163.5	206.5	285	365	431	521
L9	4.5	4.8	7.2	10	12	15	15
L10	10	12.5	19	28	36	42	42
C1 <sup>4</sup>	46	46	70	100	130	165	215
C2 <sup>4</sup>	M4 x 0.7P	M4 x 0.7P	M5 x 0.8P	M6 x 1P	M8 x 1.25P	M10 x 1.5P	M12 x 1.75P
C3 <sup>4</sup>	≤11	≤11 / ≤12	≤14 / ≤15.875 / ≤16	≤19 / ≤24	≤32	≤38	≤48
C4 <sup>4</sup>	25	25	34	40	50	60	85
C5 <sup>4</sup> <sub>G6</sub>	30	30	50	80	110	130	180
C6 <sup>4</sup>	3.5	3.5	8	4	5	6	6
C7 <sup>4</sup>	42	42	60	90	115	142	190
C8 <sup>4</sup>	29.5	29.5	19	17	19.5	22.5	29
C9 <sup>4</sup>	90.5	99.5	126.5	165	205	254.5	323.5
C10 <sup>4</sup>	8.75	8.75	13.5	10.75	13	15	20.75
B1 <sub>h9</sub>	5	5	6	10	12	16	20
H1	15	18	24.5	35	43	59	79.5

4. C1-C10 are motor specific dimensions (metric std shown). Refer to Apexdyna.com and Design Tool to view your specific motor mounting system.



# Selection of the Optimum Gearbox

## Selection of the Optimum Gearbox

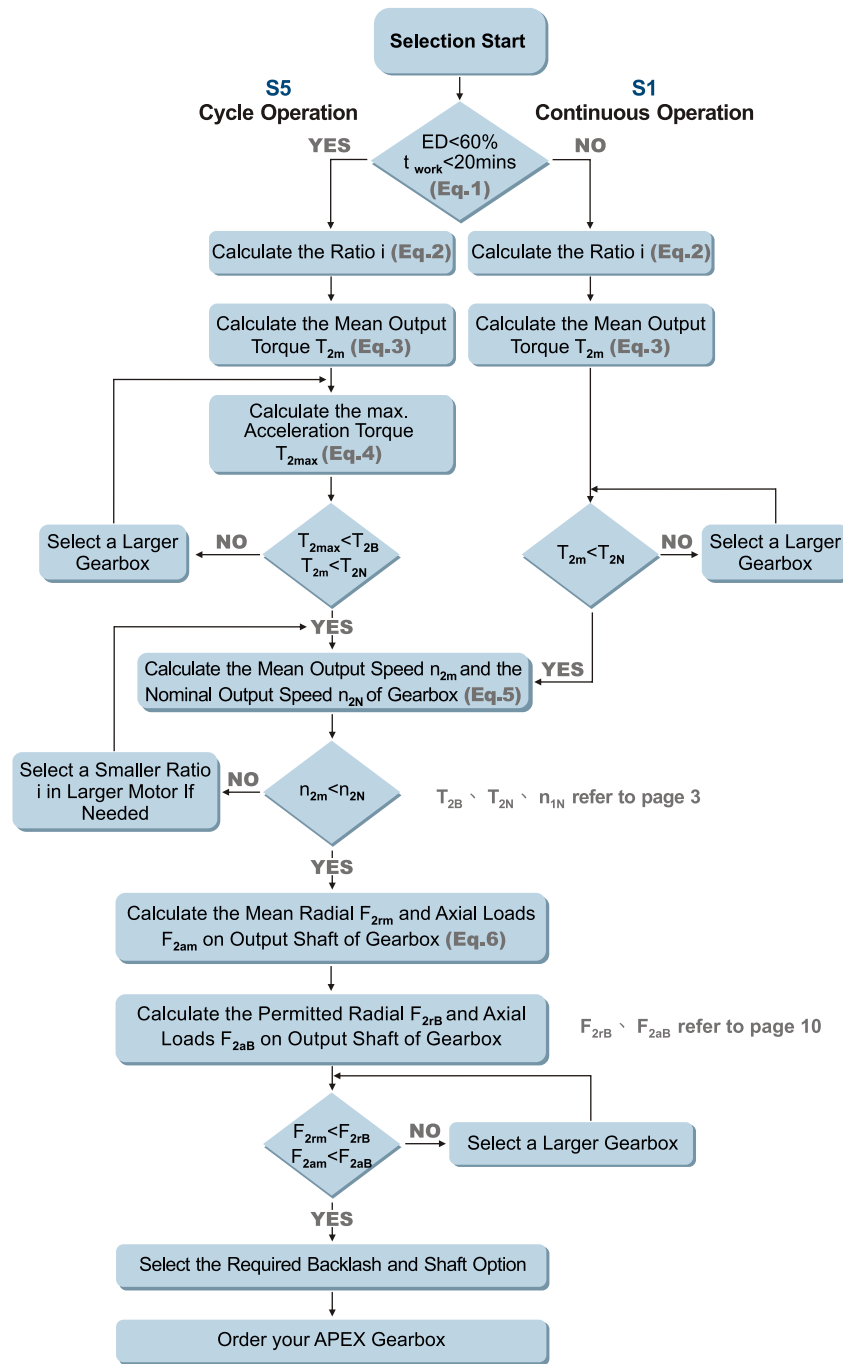

### Recommended (for S5 Cycle Operation)

The general design is given for

$$\frac{J_L}{i^2} \leq 4 \times J_m$$

The optimal design is given for

$$\frac{J_L}{i^2} \cong J_m$$

$J_L$  Load Inertia  
 $J_m$  Motor Inertia

# Permitted Radial and Axial Loads on Output Shaft of the Gearbox

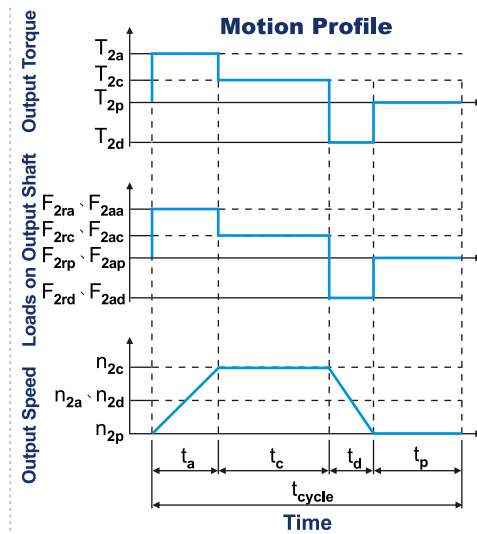

$$1. ED = \frac{t_a + t_c + t_d}{t_{cycle}} \times 100\%, t_{work} = t_a + t_c + t_d$$

Index : a. Acceleration, c. Constant, d. Deceleration, p. Pause (Eq.1)

$$2. i \cong \frac{n_m}{n_{work}}$$

$n_m$  Output Speed of the Motor  
 $n_{work}$  Working Speed (Eq.2)

$$3. T_{2m} = \sqrt[3]{\frac{n_{2a} \times t_a \times T_{2ra}^3 + n_{2c} \times t_c \times T_{2rc}^3 + n_{2d} \times t_d \times T_{2rd}^3}{n_{2a} \times t_a + n_{2c} \times t_c + n_{2d} \times t_d}}$$

(Eq.3)

$$4. T_{2max} = T_{mB} \times i \times k_s \times \eta$$

where  $K_s$  is

$K_s$	No. of Cycles / hr
1.0	0 ~ 1,000
1.1	1,000 ~ 1,500
1.3	1,500 ~ 2,000
1.6	2,000 ~ 3,000
1.8	3,000 ~ 5,000

$T_{mB}$  Max. Output Torque of the Motor  
 $\eta$  Efficiency of the Gearbox (Eq.4)

$$5. n_{2a} = n_{2d} = \frac{1}{2} \times n_{2c}$$

$$n_{2m} = \frac{n_{2a} \times t_a + n_{2c} \times t_c + n_{2d} \times t_d}{t_a + t_c + t_d}$$

$$n_{2N} = \frac{n_{1N}}{i}$$

(Eq.5)

$$6. F_{2rm} = \sqrt[3]{\frac{n_{2a} \times t_a \times F_{2ra}^3 + n_{2c} \times t_c \times F_{2rc}^3 + n_{2d} \times t_d \times F_{2rd}^3}{n_{2a} \times t_a + n_{2c} \times t_c + n_{2d} \times t_d}}$$

$$F_{2am} = \sqrt[3]{\frac{n_{2a} \times t_a \times F_{2aa}^3 + n_{2c} \times t_c \times F_{2ac}^3 + n_{2d} \times t_d \times F_{2ad}^3}{n_{2a} \times t_a + n_{2c} \times t_c + n_{2d} \times t_d}}$$

(Eq.6)

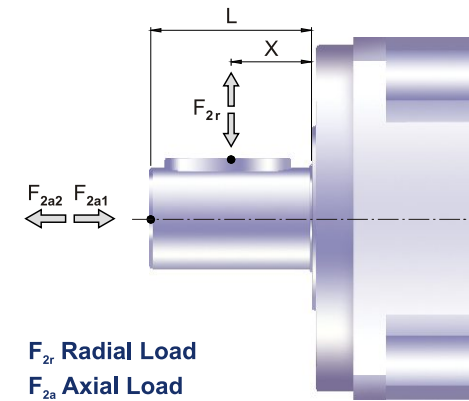

The permitted radial and axial loads on output shaft of the gearbox depend on the design of the gearbox supporting bearings. APEX use the extension straddle oversized ball bearing design. It can take heavy load from both axes.

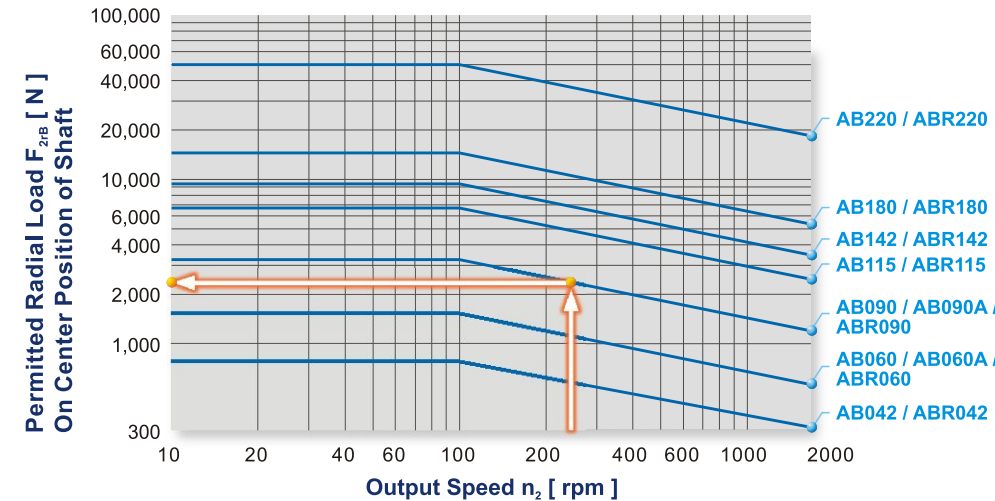

If radial force  $F_{2r}$  exert on the center of the output shaft  $X=1/2 \times L$ . Under various operating condition the lifetime is over 20,000 hours\*. The permitted radial load is given on left diagram.

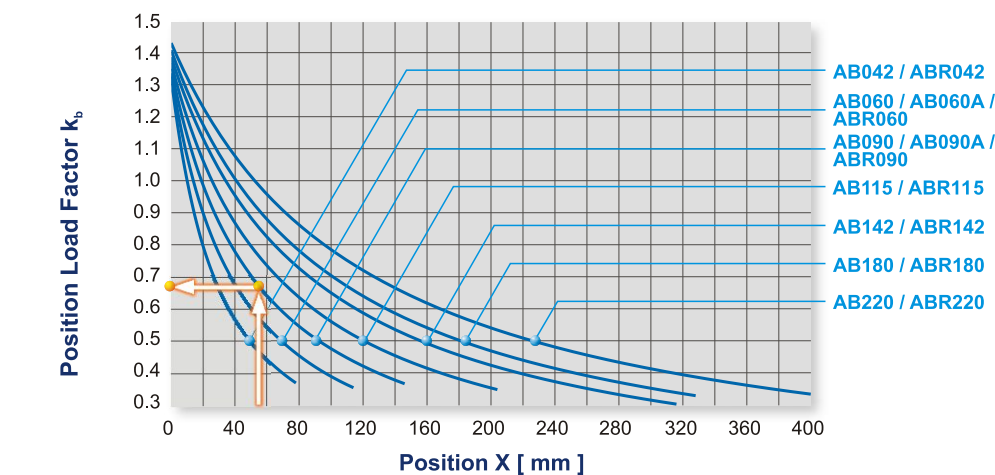

If radial force  $F_{2r}$  not exert on the center of the output shaft  $X < 1/2 \times L$  or  $X > 1/2 \times L$ . The permitted radial and axial load can be calculated by the position load factor  $K_b$  on the left diagram.

\* S1 service life 10,000 hrs