

## The Best Choice for the Most Benefit!

At LS Mecapion, we are committed to providing premium benefits to all of our customers.

# DC Servo User Manual

**PHOENIX Series**

EtherCAT<sup>®</sup>  
Conformance tested

Ver1.0



### Safety Precautions

- Read all safety precautions before using this product.
- After reading this manual, store it in a readily accessible location for future reference.

**LS** 메카피온



# Introduction



Thank you for choosing the LS Mecapion Phoenix Series.

This user manual describes how to use this product safely and efficiently.

Failure to comply with the guidelines outlined in this manual may cause personal injury or damage to the product. Be sure to read this manual carefully before using this product and follow all guidelines contained therein.

- The contents of this manual are subject to change without notice.
- The reproduction of part or all of the contents of this manual in any form, by any means or for any purpose is strictly prohibited without the explicit written consent of LS Mecapion.
- LS Mecapion retains all patents, trademarks, copyrights and other intellectual property rights to the material in this manual. The information contained in this manual is intended for use with LS Mecapion products only.

Safety precautions are categorized as either Warnings or Cautions, depending on the severity of the precaution.

Precautions	Meaning
 <b>Danger</b>	Failure to comply with these guidelines may cause serious injury or death.
 <b>Caution</b>	Failure to comply with these guidelines may cause personal injury or property damage.

Depending on the situation, these cautions may also result in serious injury.

## ■ Electric Safety Precautions

### **Danger**

- Before wiring or inspection, turn off the power. Wait 15 minutes and then check the voltage with a voltage tester.
- Ground the servo drive and the servo motor.
- Only specially trained technicians may perform wiring on this product.
- Install both the servo drive and servo motor before performing any wiring.
- Do not operate the device with wet hands.
- Do not open the servo drive cover during operation.
- Do not operate the device with the servo drive cover removed.
- Even if the power is off, do not remove the servo drive cover.

## ■ Fire Safety Precautions

### **Caution**

- Install the servo drive on non-combustible materials.
- Disconnect the input power if the servo drive malfunctions.

## ■ Installation Precautions

Store and operate this product under the following environmental conditions.

Environment	Conditions
Operating temperature	0 ~ 50 [°C]
Storage temperature	-20 ~ 65 [°C]
Operating humidity	Below 90% RH (no condensation)
Storage humidity	
Altitude	1000 m or lower
Spacing	When installing 1 unit: More than 40 mm at the top and bottom of the control panel More than 10 mm on the left and right sides of the control panel When installing 2 or more units: More than 100 mm at the top of the control panel More than 40 mm at the bottom of the control panel More than 30 mm on the left and right sides of the control panel More than 2 mm between units Refer to 2.1.2 Wiring the Control Panel.
Others	Ensure the installation location is free from dust, iron, corrosive gas or combustible gas. Ensure the installation location is free from vibrations or hard impact.

### Caution

- Install the product in the correct orientation.
- Do not drop the product or expose it to hard impact.
- Install this product in a location that is free from water, corrosive gas, combustible gas or flammable materials.
- Install this product in a location capable of supporting the weight of this product.
- Do not stand on the product or place heavy objects on top of it.
- Always maintain the specified spacing when installing the servo drive.
- Ensure that no conductive or flammable materials enter the servo drive.

## ■ Wiring Precautions

### Caution

- Always use DC 24 - 80 V input power for the servo drive.
- Always connect the servo drive to a ground terminal.
- Do not connect commercial power directly to the servo motor.
- Do not connect commercial power directly to the U, V, W output terminals of the servo drive.
- Connect the U, V, W output terminals of the servo drive directly to the U, V, W input terminals of the servo motor, but do not install magnetic contactors between the wires.
- Always use pressurized terminals with insulation tubes when connecting the servo drive power terminal.
- When wiring, be sure to separate the U, V, and W cables for the servo motor power and encoder cable.
- Always use the robot cable if the motor moves.
- Before wiring the power lines, turn off the input power of the servo drive, and then wait until the capacitor is completely discharged.

## ■ Startup Precautions

### Caution

- Check the input voltage (DC 24 - 80 V) and power unit wiring before supplying power to the device.
- The servo must be in the OFF mode when you turn on the power.
- Be sure to check the motor ID, encoder type, and encoder pulse before supplying power.
- After supplying power, be sure to first set the third party parameter for [0x2800]~, encoder type for [0x2001], and the encoder resolution for [0x2002].
- After you complete the above settings, set the drive mode for the servo drive, which is connected to the upper level controller, in [0x6060].
- Refer to Chapter 1.4 System Configuration to perform I/O wiring for the servo drive according to each drive mode.
- You can check the on/off status of each I/O contact point from the digital input of [0x60FD].

## ■ Handling and Operating Precautions

### ⚠ Caution

- Check and adjust each parameter before operation.
- Do not touch the rotating unit of the motor during operation.
- Do not touch the heat sink during operation.
- Be sure to attach or remove the I/O and ENC connectors when the power is off.
- Extreme changes in parameter values may cause system instability.

## ■ Usage Precautions

### ⚠ Caution

- Install an emergency cut-off switch, which immediately stops operation in an emergency.
- Reset the alarm when the servo is off. Be warned that the system restarts immediately if the alarm is reset while the servo is on.
- Use a noise filter or DC reactor to minimize electromagnetic interference. This prevents nearby electrical devices from malfunctioning due to electromagnetic interference.
- Brake failure can occur if the electric brake degrades or the mechanical structure is improper (e.g. if the ball screw and servo motor are combined via the timing belt). Install an emergency stop device to ensure mechanical safety.

## ■ Malfunction Precautions

### ⚠ Caution

- During emergencies or device malfunctions, use a servo motor with an electric brake or install an external brake system.
- If an alarm occurs, solve the underlying cause of the problem. After ensuring safe operation, deactivate the alarm and resume operation.
- Do not approach the machine until the problem is solved.

## ■ Repair/Inspection Precautions

### Caution

- Before maintenance or inspection, turn off the power. Wait 15 minutes and then check the voltage with a voltage tester. Enough voltage may remain in the condenser after the power is turned off to cause an electric shock.
- Only authorized personnel may repair and inspect the device or replace parts.
- Do not modify this device in any way.

## ■ General Precautions

### Caution

- This user manual is subject to change due to product modifications or changes in standards. If such changes occur, we issue a new user manual with a new product number.

## ■ Product Application

### Caution

- This product is not designed or manufactured for machines or systems intended to sustain human life.
- This product is manufactured under strict quality control conditions. Nevertheless, install safety devices if installing the product in a facility where product malfunctions may result in a major accident or a significant loss.

## ■ EEPROM Lifespan

### Caution

- The EEPROM is rewritable up to 4 million times for the purpose of recording parameter settings and other information. Depending on the lifespan of the EEPROM, the servo drive may malfunction if the total number of these tasks exceeds 4 million:
  - EEPROM record as a result of parameter changes
  - EEPROM record as a result of an alarm



# Table of Contents

<b>1.</b>	<b>Product Configuration .....</b>	<b>1-1</b>
1.1	Product Verification.....	1-1
1.2	Product Specifications .....	1-2
1.3	Component Names.....	1-6
1.3.1	Servo Drive Components .....	1-6
1.3.2	Status LED Display .....	1-7
1.4	Example of System Configuration.....	1-8
<b>2.</b>	<b>Wiring and Connection .....</b>	<b>2-1</b>
2.1	Servo Drive Installation.....	2-1
2.1.1	Installation and Usage Environment .....	2-1
2.1.2	Wiring the Control Panel.....	2-2
2.2	Internal Block Diagram of the Servo Drive .....	2-3
2.2.1	Block Diagram of the Drive .....	2-3
2.3	Power Supply Wiring .....	2-4
2.3.1	Power Input Sequence .....	2-4
2.3.2	Power Circuit Electrical Components .....	2-5
2.4	Wiring for Input/Output Signals .....	2-6
2.4.1	Names and Functions of Digital Input Signals .....	2-6
2.4.2	Names and Functions of Digital Output Signals.....	2-12
2.4.3	Names and Functions of Analog Input Signals .....	2-14
2.4.4	Names and Functions of Analog Output Signals.....	2-15
2.4.5	Names and Functions of Pulse Train Input Signals .....	2-17
2.4.6	Names and Functions of Encoder Output Signals .....	2-18
2.4.7	Input/Output Signal Wiring Diagram .....	2-19
2.5	Wiring of Encoder Signals (Encoder Connector).....	2-20
2.6	Wiring for Safety Function Signals.....	2-22
2.6.1	Example of Connecting Safety Function Signals .....	2-23
2.6.2	Bypass Wiring of Safety Function Signals .....	2-23
2.7	Brake Connectors.....	2-24
2.8	Wiring for EtherCAT Communication Signals.....	2-25
2.8.1	Names and Functions of EtherCAT Communication Signals .....	2-25
2.8.2	Example of Drive Connection .....	2-26
<b>3.</b>	<b>EtherCAT Communication .....</b>	<b>3-27</b>
3.1	Structure of CANopen over EtherCAT .....	3-27
3.1.1	EtherCAT State Machine .....	3-28
3.2	Status LED .....	3-29
3.3	PDO Assignments .....	3-31

3.4	Synchronization Using the DC (Distributed Clock).....	3-34
3.5	Emergency Messages.....	3-35
<b>4.</b>	<b>CiA402 Drive Profile.....</b>	<b>4-36</b>
4.1	State machine.....	4-36
4.2	Operation Modes.....	4-38
4.3	Position Control Modes.....	4-40
4.3.1	Cyclic Synchronous Position Mode.....	4-40
4.3.2	Profile Position Mode.....	4-43
4.4	Velocity Control Modes.....	4-48
4.4.1	Cyclic Synchronous Velocity Mode.....	4-48
4.4.2	Profile Velocity Mode.....	4-51
4.5	Torque Control Modes.....	4-54
4.5.1	Cyclic Synchronous Torque Mode.....	4-54
4.5.2	Profile Torque Mode.....	4-56
4.6	Homing.....	4-58
4.6.1	Homing Methods.....	4-58
4.7	Touch Probe Function.....	4-72
<b>5.</b>	<b>Drive Application Functions.....</b>	<b>5-2</b>
5.1	Settings for Input/Output Signals.....	5-2
5.1.1	Assignments for Digital Input Signals.....	5-2
5.1.2	Assignment of Digital Output Signals.....	5-5
5.1.3	Use of User I/O.....	5-8
5.2	Electric Gear Setup.....	5-11
5.2.1	Electric Gear.....	5-11
5.3	Settings Related to Speed Control.....	5-13
5.3.1	Smooth Acceleration and Deceleration.....	5-13
5.3.2	Servo-lock Function.....	5-14
5.3.3	Signals Related to Speed Control.....	5-15
5.4	Settings Related to Position Control.....	5-15
5.4.1	Position Command Filter.....	5-15
5.4.2	Signals Related to Position Control.....	5-17
5.5	Settings Related to Torque Control.....	5-18
5.5.1	Speed Limit Function.....	5-18
5.6	Positive/Negative Limit Settings.....	5-18
5.7	Setting the Brake Output Signal Function.....	5-19
5.8	Torque Limit Function.....	5-21
5.9	Gain Switching Function.....	5-23
5.9.1	Gain Group Switching.....	5-23
5.9.2	P/PI Control Switching.....	5-25
5.10	Motor Overload Prevention Function.....	5-27
5.10.1	<b>I<sup>2</sup>T</b> Prevention by Algorithm.....	5-27

5.10.2	Prevention by Motor Thermal Time Constant .....	5-28
5.11	Configuration of the Drive Node Address (ADDR).....	5-29
<b>6.</b>	<b>Safety Functions .....</b>	<b>6-30</b>
6.1	Safe Torque Off (STO) Function .....	6-30
6.2	Example of Using the Safety Function .....	6-32
6.3	How to Verify the Safety Function .....	6-32
6.4	Precautions for Using the Safety Function .....	6-32
<b>7.</b>	<b>Tuning.....</b>	<b>7-34</b>
7.1	Offline Auto Gain Tuning.....	7-34
7.2	Online Auto Gain Tuning.....	7-35
7.3	Manual Gain Tuning .....	7-37
7.3.1	Gain Tuning Sequence .....	7-37
7.4	Vibration Control.....	7-39
7.4.1	Notch Filter.....	7-39
7.4.2	Adaptive Filter .....	7-40
7.4.3	Vibration Control (Damping) Filter .....	7-41
7.5	Analog Monitor .....	7-42
<b>8.</b>	<b>Procedure Function.....</b>	<b>8-46</b>
8.1	Manual Jog Operation .....	8-46
8.2	Programmed Jog Operation .....	8-47
8.3	Deleting Alarm History .....	8-48
8.4	Auto Gain Tuning.....	8-49
8.5	Index Pulse Search .....	8-49
8.6	Absolute Encoder Reset.....	8-50
8.7	Instantaneous Maximum Torque Initialization .....	8-51
8.8	Phase Current Offset Tuning .....	8-51
8.9	Software Reset.....	8-52
8.10	Commutation .....	8-52
<b>9.</b>	<b>Full-Closed Control .....</b>	<b>9-53</b>
9.1	Full-Closed Control Internal Configuration.....	9-53
9.2	Full-Closed Control Parameter Settings.....	9-54
<b>10.</b>	<b>Indexing Operation.....</b>	<b>10-61</b>
10.1	Control Type .....	10-61
10.2	Indexing Position Operation.....	10-61
10.2.1	Setting the Coordinates .....	10-65
10.2.2	Index Structure .....	10-67
10.3	Pulse Input Position Operation .....	10-68
10.4	Speed Operation .....	10-72
10.5	Torque Operation.....	10-76

10.6	Indexing Position Operation.....	10-1
10.6.1	Index Concept.....	10-1
10.6.2	Index Type.....	10-8
10.6.3	Functions of Index Input Signals.....	10-16
10.6.4	Functions of Index Output Signals.....	10-20
10.6.5	Analog Speed Override.....	10-23
10.7	Pulse Input Position Operation.....	10-1
10.7.1	Setting Functions of Pulse Input Logic.....	10-2
10.7.2	Setting Functions of Pulse Input Filter.....	10-3
10.8	Speed Operation.....	10-5
10.8.1	Setting Functions of Speed Command Switch Select.....	10-5
10.8.2	Analog Speed Command.....	10-7
10.8.3	Multi-Stage Speed Command.....	10-9
10.9	Torque Operation.....	10-9
10.9.1	Analog Torque Command Scale.....	10-9
10.9.2	Speed Settings during Torque Operation.....	10-10
10.10	Operation Mode Switching.....	10-12
<b>11.</b>	<b>Object Dictionary.....</b>	<b>11-2</b>
11.1	Data Type.....	11-2
11.2	General Objects.....	11-2
11.3	Manufacturer Specific Objects.....	11-22
11.4	Index Objects.....	11-111
11.5	CiA402 Objects.....	11-117
<b>12.</b>	<b>Maintenance and Inspection.....</b>	<b>12-1</b>
12.1	Diagnosing and Troubleshooting Abnormalities.....	12-1
12.2	Servo Alarm.....	12-1
12.3	Servo Warning.....	12-10
12.4	Servo Drive Overload Curve.....	12-12
12.3	Options and Peripheral Devices.....	12-1
<b>13.</b>	<b>Test Drive.....</b>	<b>13-1</b>
13.1	Preparation for Operation.....	13-1
13.2	Test Drive using Drive CM.....	13-2
13.3	Test Drive Using TwinCAT System Manager.....	13-8
13.4	Test Drive Using LSIS PLC (XGT + PN8B).....	13-17
13.5	Preparation for Indexing Operation.....	13-24
13.5.1	Indexing Position Mode.....	13-26
13.5.2	Pulse Input Position Mode.....	13-30
13.5.3	Speed Mode.....	13-33
13.5.4	Torque Operation.....	13-37
<b>14.</b>	<b>Appendix.....</b>	<b>14-40</b>

14.1	Firmware Update .....	14-40
14.1.1	Use of USB OTG.....	14-40
14.1.2	Use of Drive CM.....	14-41



# 1. Product Configuration

## 1.1 Product Verification

1. Check the nameplate to verify it matches the model ordered.
  - Does the servo drive nameplate match?
2. Check the exterior of the device.
  - Are there any foreign substances or moisture?
  - Is there any discoloration, contaminant, damage or disconnected wire?
  - Are the bolts tightly fastened to the joints?

## 1.2 Product Specifications

### ■ Phoenix Series Product Type

# PHOX-03-080NS-XX00

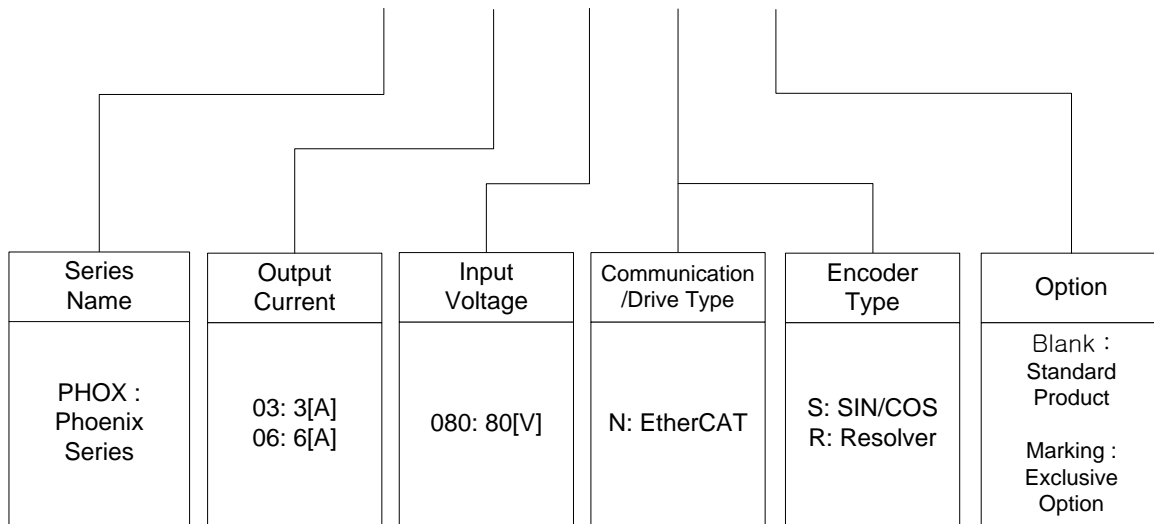



### ■ Servo Drive Specifications

Model name		DC 3A	DC 6A
Input power	Main power	DC 24~80[V]	
	Control power	DC 24~80[V]	
Rated current (A)		3	6
Peak current (A)		9[A], >1[sec]	18[A], >1[sec]
1 <sup>st</sup> Encoder Encoder A		Quadrature(max. 10Mpps after x4) - With and without halls - Differential Serial Encoder(absolute, incremental) - BiSS(B,C) - Endat2.2 - Tamagawa serial - SSI	
2 <sup>nd</sup> Encoder Encoder B		Quadrature(max. 10Mpps after x4) - without halls - Differential Serial Encoder(absolute, incremental) - BiSS(B,C) - Endat2.2 - Tamagawa serial - SSI Analog Encoder - Sinusoidal(1Vpp), Analog hall(Sin/Cos) - Resolver(Optional)	
Control performance	Speed control range	Maximum 1: 5000	
	Frequency response	Maximum 1 kHz or above (when the 19-bit serial encoder is applied).	
	Speed variation	$\pm 0.01\%$ or lower (when the load changes between 0 and 100%) $\pm 0.1\%$ or less (temperature of $25^{\circ}\text{C} \pm 10$ )	
	Torque control repetition accuracy	Within $\pm 1\%$	
	Input	4 Mpps, line drive	

Model name		DC 3A	DC 6A
Item			
	frequency		
	Input pulse method	Symbol + pulse series, CW + CCW, A/B phase	
EtherCAT Communication Specifications	Communication specifications	FoE (Firmware download) EoE (Parameter settings, adjustment and auxiliary functions, and parameter copy through UDP) CoE (IEC 61158 Type12, IEC 61800-7 CiA 402 drive profile)	
	Physical layer	100BASE-TX(IEEE802.3)	
	Connector	RJ45 x 2	
	Distance	Within 100 m between nodes	
	DC (Distributed Clock)	Synchronization by DC mode, minimum DC cycle: 250 us	
	LED display	LinkAct IN, LinkAct OUT, RUN, ERR	
	Cia402 drive profile	Profile Position Mode Profile Velocity Mode Profile Torque Mode Cyclic Synchronous Position Mode Cyclic Synchronous Velocity Mode Cyclic Synchronous Torque Mode Homing Mode	
Digital input/output	Digital input	A total of 4 input channels (allocable) Possible to allocate a total of 33 input functions (*POT, *NOT, *HOME, *STOP, PCON, GAIN2, P_CL, N_CL, PROBE1, PROBE2, EMG, A_RST, SV_ON, START, PAUSE, REGT, HSTART, ISEL0~5, ABS_RQ, JSTART, JDIR, PCLR, AOVR, INHIB, SPD1, SPD2, SPD3, MODE) Note: The signals marked with * are allocated by default.	
	Digital output	A total of 4 output channels (allocable) Possible to allocate a total of 19 outputs (*BRAKE, *ALARM, *READY, *ZSPD, INPOS1, INPOS2, TLMT, VLMT, INSPD, WARN, TGON, ORG, EOS, IOUT0, IOUT1, IOUT2, IOUT3, IOUT4, IOUT5) Note: The signals marked with * are allocated by default.	
Analog input/output	Analog input	Input voltage range: Differential $\pm 10$ V (16-bit resolution) 1 channel. Torque limit value is set with an analog voltage.	
	Analog output	A total of 2 channels (allocable) Possible to allocate a total of 15 outputs	

Model name		DC 3A	DC 6A
Item			
Safety Functions		2 input channels (STO1, STO2)	
Encoder output method		AO(+/-), BO(+/-), ZO(+/-) (line drive output, maximum 6.4 Mpps)	
USB Communi- cation	Function	Firmware download, parameter settings, adjustment and auxiliary functions, and parameter copy function	
	Communication specifications	Compliant with the USB 2.0 Full Speed Standard	
	Connectable device	PC or USB storage medium	
Built-in functions	Self-setting function	Possible to set the drive node address by using the dip switch	
	Add-on functions	Gain adjustment, alarm history, JOG operation, and home search	
	Protection functions	Overcurrent, overload, current limit over, overheat, overvoltage, undervoltage, encoder error, position follow error, current sensing error	
Environment	Operating temperature	0 ~ 50[°C]	
	Storage temperature	-20 ~ 65[°C]	
	Humidity	Below 90% RH (no condensation)	
	Environment	Indoors, areas free from corrosive or combustible gases, liquids, or dust.	

# 1.3 Component Names

## 1.3.1 Servo Drive Components

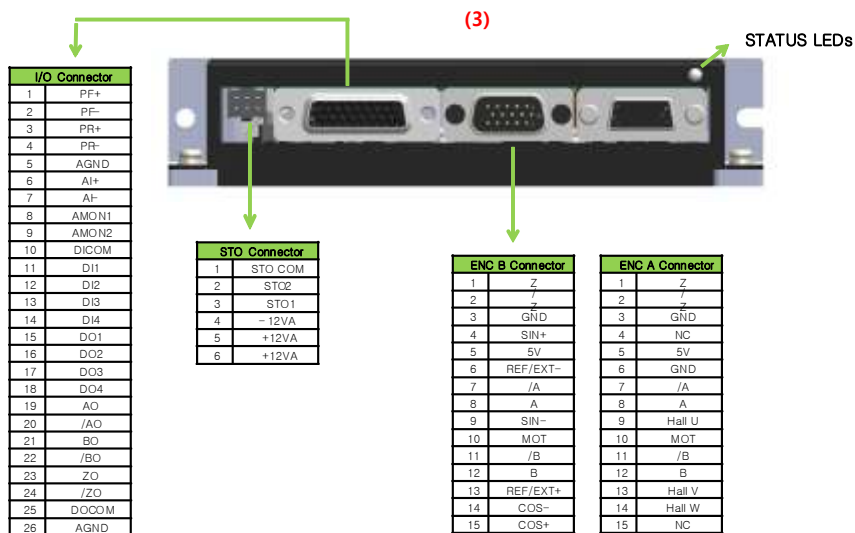
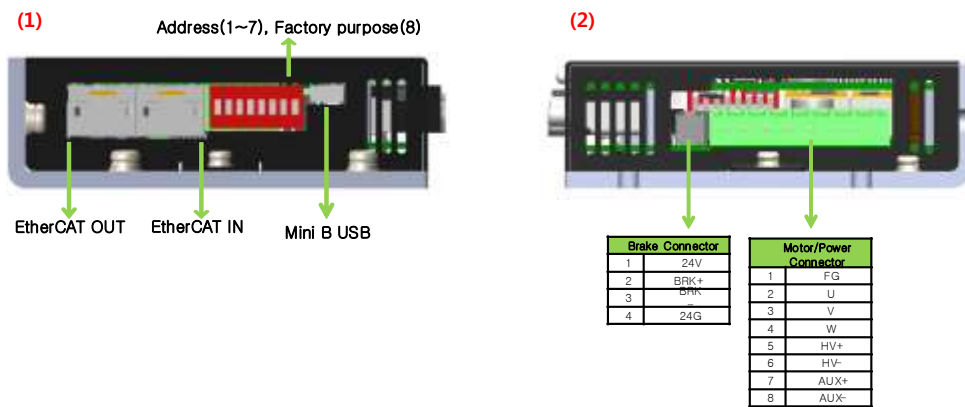
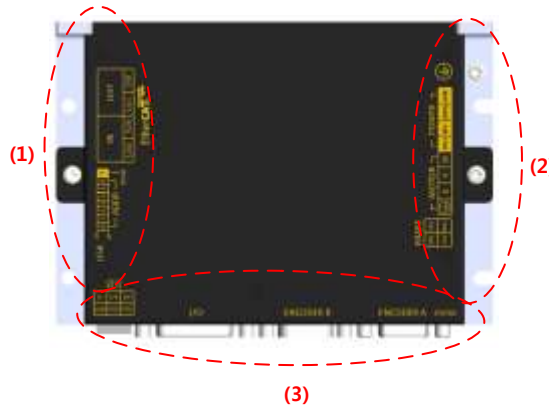

2.5 Refer to Wiring of Encoder Signals





### 1.3.2 Status LED Display

The status LEDs on the front of the drive indicate the states and errors of the drive, as shown in the following figure. The status LED uses two colors (green/red) to indicate a total of 6 states.



The green LED shows the servo operation status and the red LED shows the servo error status. Refer to the table below for details on the LED display.

■ Servo Status According to Bi-color LED Display

LED status	Description
GREEN LED Flickering	 <p>Drive is booting.</p>
GREEN LED Blinking	 <p>Bootting was finished properly, and the drive is in the ready state.</p>
GREEN LED ON	Servo is on (SVON).
RED LED Blinking	 <p>Servo alarm is generated.</p>
RED LED Flickering	 <p>Firmware is being downloaded.</p>

<p>RED LED Double Flash</p>	
<p>Software error has occurred. Contact our service center.</p>	

## 1.4 Example of System Configuration

The figure below shows an example of system configuration using this drive.

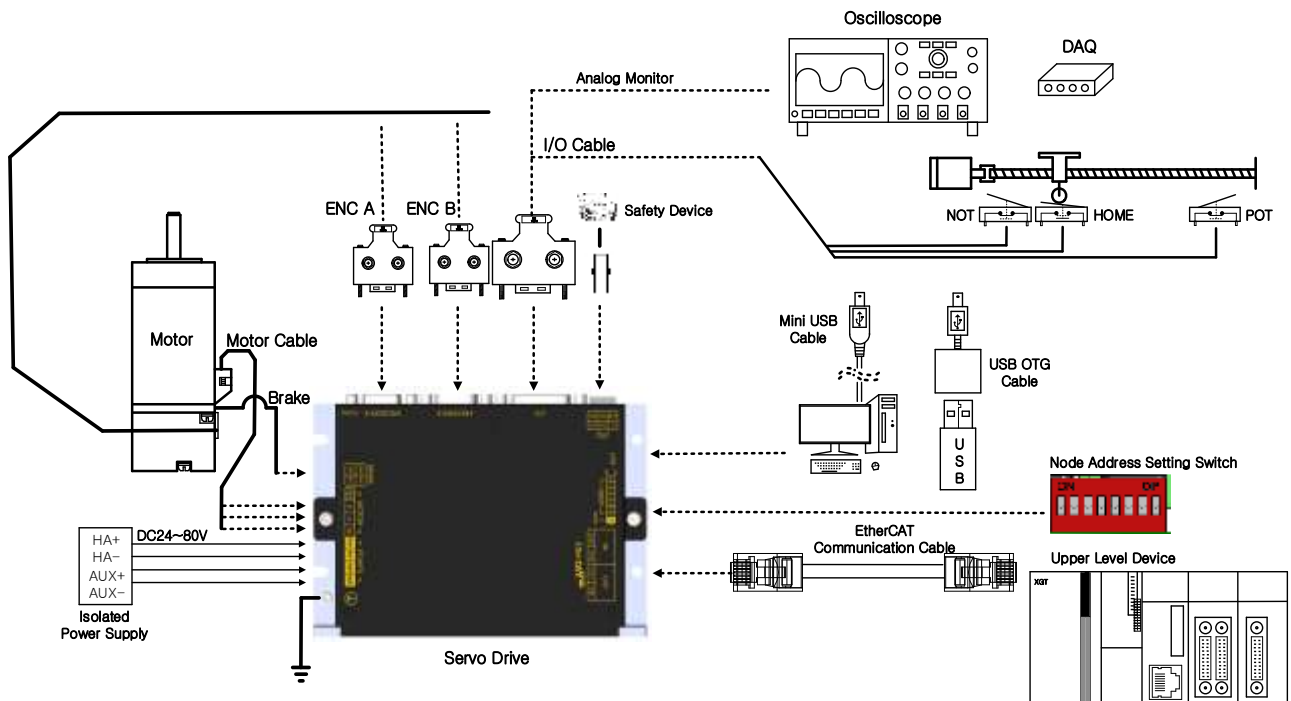

## 2. Wiring and Connection

### 2.1 Servo Drive Installation

#### 2.1.1 Installation and Usage Environment

Item	Environmental conditions	Notes
Operating temperature	0~50[°C]	<p><b>⚠ Caution</b></p> <p>Install a cooling fan on the control panel to maintain an appropriate temperature.</p>
Operating humidity	Below 90% RH	<p><b>⚠ Caution</b></p> <p>During prolonged periods of inactivity, moisture from condensation or frost may develop inside the drive and damage it. Remove all moisture before operating the drive after a prolonged period of inactivity.</p>
External vibration	Vibration acceleration 19.6 $\text{m/s}^2$ or lower	Excessive vibration reduces the lifespan of the machine and may cause malfunctions.
Ambient conditions		<ul style="list-style-type: none"> <li>▪ Do not expose the device to direct sunlight.</li> <li>▪ Do not expose the device to corrosive or combustible gases.</li> <li>▪ Do not expose the device to oil or dust.</li> <li>▪ Ensure that the device receives sufficient ventilation.</li> </ul>

## 2.1.2 Wiring the Control Panel

When installing the control panel, comply with the spacing specified in the following figures.

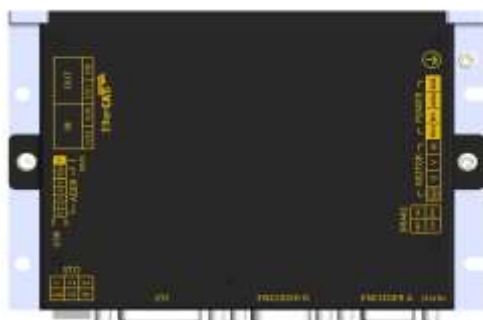
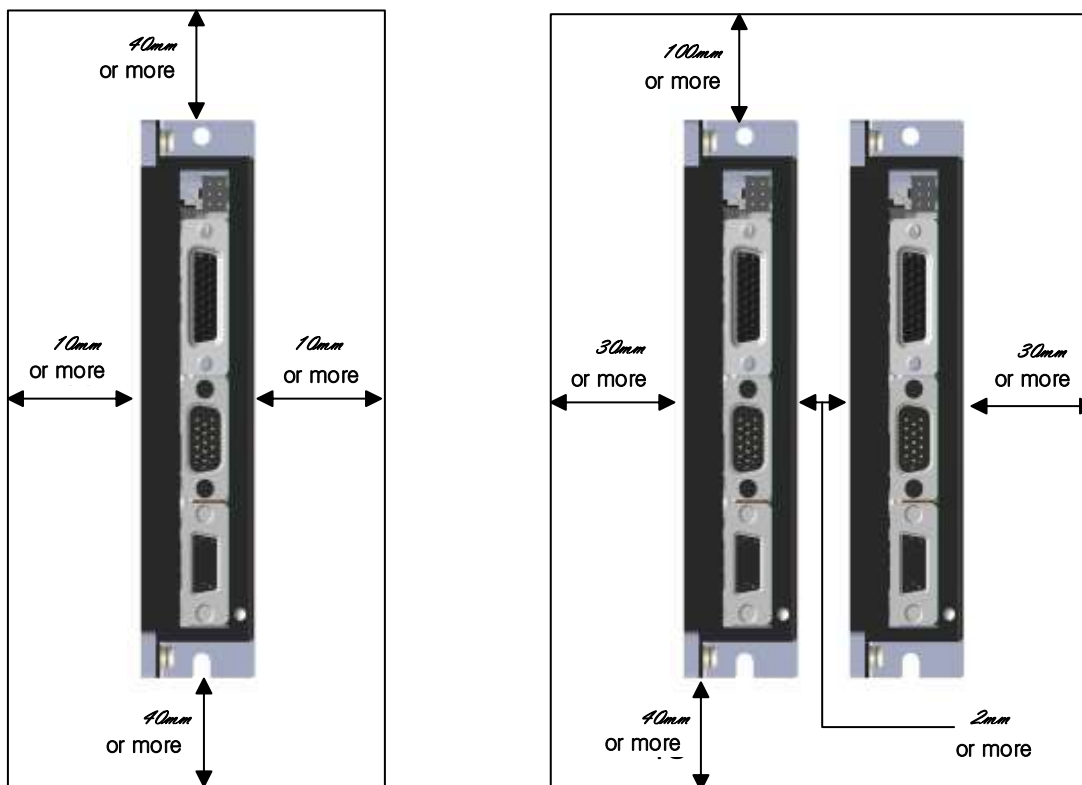

### ⚠ Caution

- Assemble the servo drive control panel so it is flat against the wall.
- Make sure any metal filings from drilling do not enter the drive when assembling the control panel.
- Make sure oil, water, and metal filings do not enter the drive through the gaps or roof of the control panel.
- Protect the control panel by spraying compressed air in the areas where harmful gases or dust



accumulate.

## 2.2 Internal Block Diagram of the Servo Drive

### 2.2.1 Block Diagram of the Drive

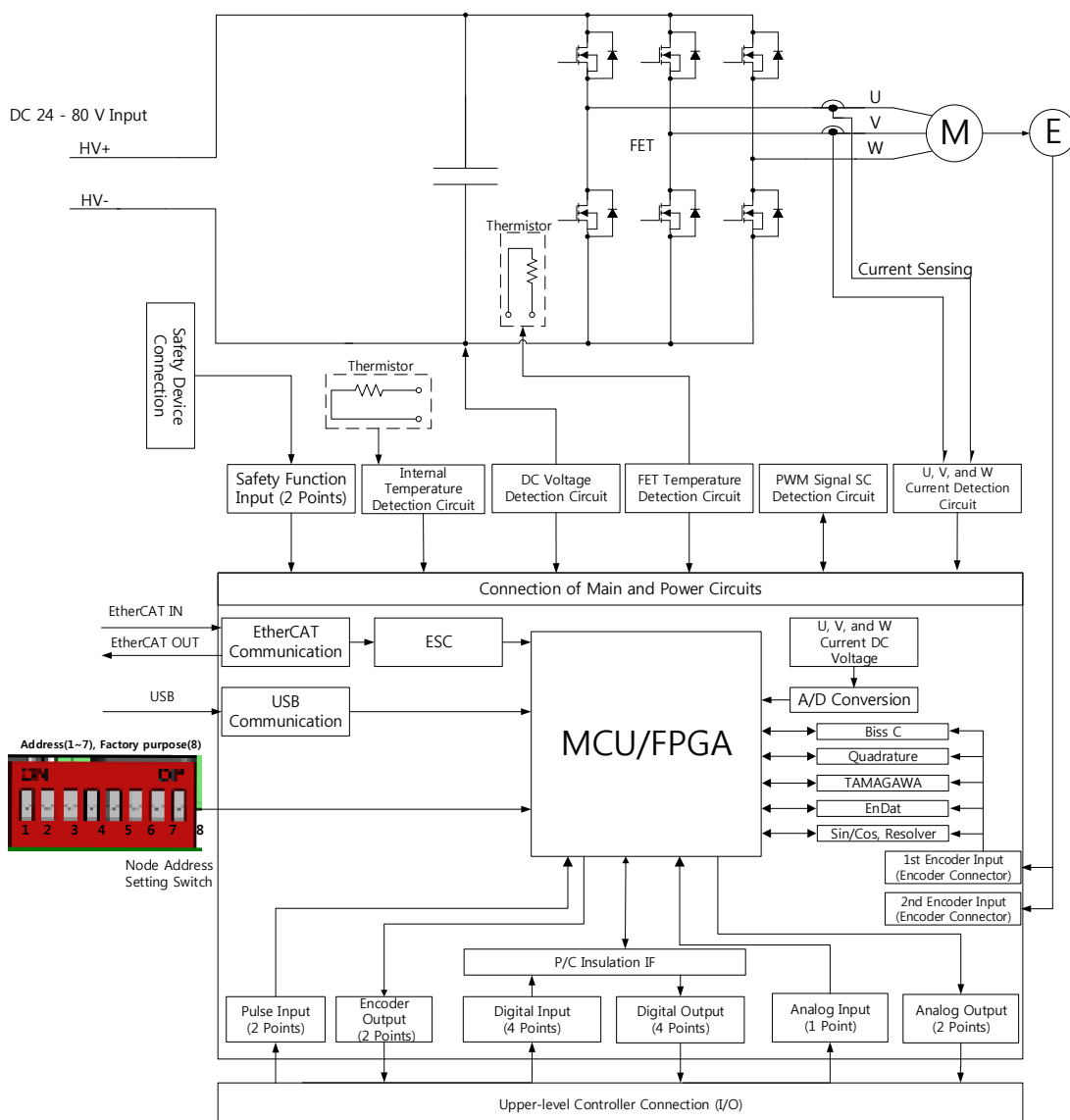

## 2.3 Power Supply Wiring

- Ensure that the input power voltage is within the acceptable range.

<b>⚠ Caution</b>
Overvoltages can damage the drive.

- If commercial power is connected to the U, V, W terminals of the drive, they may be damaged. Be sure to connect the DC input power to the HV+, HV-, AUX+, and AUX- terminals.
- Configure the system so the main power (HV+, HV-) and auxiliary power (AUX+, AUX-) are supplied separately. Auxiliary power (AUX+, AUX-) is designed to display the drive status when the main power (HV+, HV-) is disconnected.
- High voltages may remain in the device for some time even after the main power is disconnected. Please be careful.

<b>⚡ Warnings</b>
After the main power is disconnected, use the tester to check the voltage and then carry out the wiring task. Failure to do so may result in electric shock.

- Always ground the device over the shortest possible distance. Long ground wires are susceptible to noise, which may cause the device to malfunction.

### 2.3.1 Power Input Sequence

#### ■ Power Input Sequence

- Two seconds after the power input, the alarm signal turns on (normal), and the Servo On command signal is recognized. Therefore, when the Servo On command signal is on at the same time as the power is input, the actual Servo On is activated 2 seconds later. Please keep this in mind when designing the power input sequence.

#### ■ Timing Chart

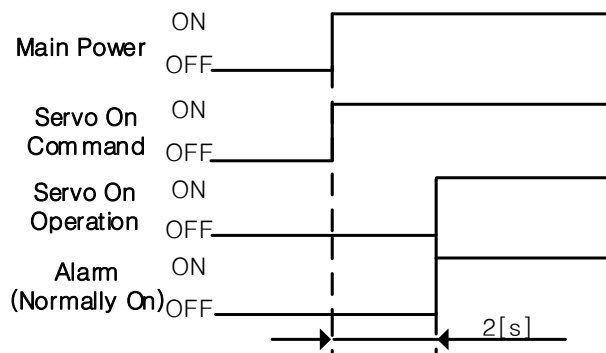

## 2.3.2 Power Circuit Electrical Components

### ■ Power and Motor Connector Specifications

- Connector : MSTB 2.5/8-ST-5.08

- Recommended wiring standards: 12 AWG - 18 AWG

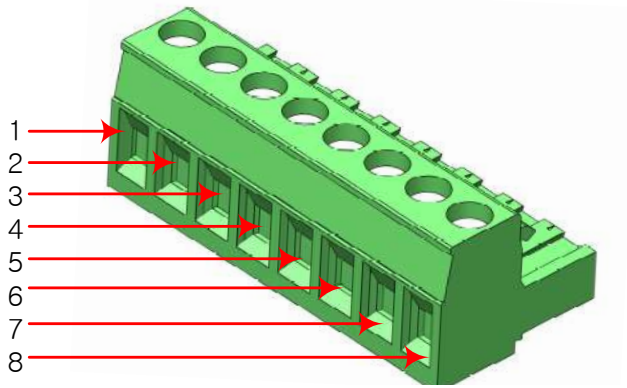

Pin No	Signal Name	Notes
1	FG	Frame Ground
2	U	These are the motor U, V, and W outputs.
3	V	
4	W	
5	HV+	These are the main power inputs.
6	HV-	
7	AUX+	These are the auxiliary power inputs. When the main power is disconnected, you can check the drive status using the auxiliary power.
8	AUX-	

Note 1) For wires to be used on the main circuit power unit, remove 7 mm of the wire sheath and use the crimp terminal.

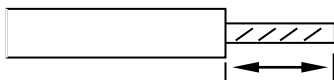

## 2.4 Wiring for Input/Output Signals

### ■ I/O Connector Specifications

- Connector : 10090769-P264ALF
- Housing : 3357-9215
- Recommended cable specifications: 13P x 0.2 SQ or 16P x 24 AWG (twisted pair/shielded cable)

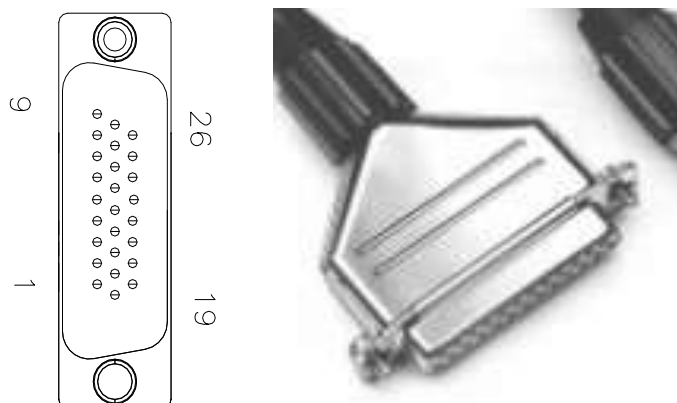

### 2.4.1 Names and Functions of Digital Input Signals

#### ■ Names and Functions of Digital Input Signals (I/O Connector)

Pin Number	Name	Assignment	Description	Function
10	DICOM		DC POWER INPUT	COMMON
11	DI1	POT	Forward (CCW) rotation prohibited	The actuator stops the servo motor to prevent it from moving beyond the motion range in the forward direction.

12	DI2	NOT	Reverse (CW) rotation prohibited	The actuator stops the servo motor to prevent it from moving beyond the motion range in the reverse direction.
13	DI3	HOME	Origin sensor	Connects the origin sensor to return to the origin.
14	DI4	STOP	Servo stop	Stops the servo motor when the contact is on.
** PCON			P control action	When the contact is on, it converts the mode from PI control to P control.
** GAIN2			Switch from Gain 1 to 2	When the contact is on, it switches the speed control from Gain 1 → to Gain 2
** PCL			Forward torque limit	When the contact is on, the forward torque limit function is activated.
** NCL			Reverse torque limit	When the contact is on, the reverse torque limit function is activated.
** PROBE1			Touch probe 1	The probe signal to rapidly store the position value (1)
** PROBE2			Touch probe 2	The probe signal to rapidly store the position value (2)
** EMG			Emergency stop	Emergency stop when the contact is on.
** ARST			Alarm reset	Resets the servo alarm.
** SVON			Servo On	When the SVON signal is on, the motor becomes operable (Servo On). If it is turned Off, the motor enters the free-run state.
** A-RST			Alarm reset	Deactivates the servo alarm.
** START			Operation start	Starts the index position operation. It can be used in index operation mode.

** REGT	Post-sensor operation	<p>If the index type is registration absolute or registration relative, the servo switches to the preset driving speed and distance when the REGT signal is on.</p> <p>It can be used in index operation mode.</p>
** EMG	Emergency stop	<p>When the EMG signal is on, the servo performs an emergency stop and a "W-80" is generated. In this case, the stop method differs depending on the [0x2013] settings.</p>
** HSTART	Homing operation start	<p>Starts the homing operation.</p> <p>It can be used in index operation mode.</p>
** ISEL0	Select index 0	<p>Select an index from 0 to 63 for the operation.</p> <p>It can be used in index operation mode.</p>
** ISEL1	Select index 1	
** ISEL2	Select index 2	
** ISEL3	Select index 3	
** ISEL4	Select index 4	
** ISEL5	Select index 5	
** PAUSE	Pause	<p>If a pause signal is received during the index operation, the servo decelerates and stops. If a pause signal is received again while the servo is paused, the index operation restarts.</p> <p>It can be used in index position operation mode.</p>
** ABSRQ	Request absolute location data	<p>Upon the absolute value encoder's request for the absolute value data, the data of the absolute value encoder are transmitted to the upper level controller in the form of quadrature pulses through the output of the encoder output signals, AO and BO.</p>
** JSTART	Jog operation	<p>When the contact is on, jog operation starts at the speed set on [0x2300].</p>

<p>** JDIR</p>	<p>Select jog rotation direction</p>	<p>Switches the rotation direction during jog operation.</p>																			
<p>** PCLR</p>	<p>Input pulse clear</p>	<p>When the contact is on, it changes the position error to 0 without receiving an input pulse. The operation mode can be set in [0x3005].</p>																			
<p>** AOVR</p>	<p>Select speed override</p>	<p>When the AOVR signal is on, it overrides the index operation speed depending on the voltage input on A-OVR (AI2). When -10 V is received, the override value becomes 0% of the index operation speed. When 0 V is received, the override value becomes 100% of the index operation speed. When +10 V is received, the override value becomes 200% of the index operation speed. It can be used in index position operation mode.</p>																			
<p>** SPD1</p>	<p>Multi-speed 1</p>	<p>Select the command rotation speed during speed control operation. Depending on the contact status, speed command will change as follows.</p> <table border="1" data-bbox="965 1440 1401 2049"> <thead> <tr> <th colspan="3">Input device</th> <th rowspan="2">Speed</th> </tr> <tr> <th>SPD1</th> <th>SPD2</th> <th>SPD3</th> </tr> </thead> <tbody> <tr> <td>X</td> <td>X</td> <td>X</td> <td>Multi-speed command 1 (Parameter 0x2312)</td> </tr> <tr> <td>O</td> <td>X</td> <td>X</td> <td>Multi-speed command 2 (Parameter 0x2313)</td> </tr> <tr> <td>X</td> <td>O</td> <td>X</td> <td>Multi-speed command 3 (Parameter 0x2314)</td> </tr> </tbody> </table>	Input device			Speed	SPD1	SPD2	SPD3	X	X	X	Multi-speed command 1 (Parameter 0x2312)	O	X	X	Multi-speed command 2 (Parameter 0x2313)	X	O	X	Multi-speed command 3 (Parameter 0x2314)
Input device			Speed																		
SPD1	SPD2	SPD3																			
X	X	X	Multi-speed command 1 (Parameter 0x2312)																		
O	X	X	Multi-speed command 2 (Parameter 0x2313)																		
X	O	X	Multi-speed command 3 (Parameter 0x2314)																		
<p>** SPD2</p>	<p>Multi-speed 2</p>																				

** SPD3	Multi-speed 3	O	O	X	Multi-speed command 4 (Parameter 0x2315)
		X	X	O	Multi-speed command 5 (Parameter 0x2316)
		O	X	O	Multi-speed command 6 (Parameter 0x2317)
		X	O	O	Multi-speed command 7 (Parameter 0x2318)
		O	O	O	Multi-speed command 8 (Parameter 0x2319)
		It can be used in speed operation mode.			
** MODE	Change operation mode	Switches the operation mode in control modes 4, 5, 6, 7, 8, and 9.			
** INHIBIT	Command pulse inhibit	Input pulses are not counted as command pulses. It can be used in pulse input position operation mode.			

Note 1)\*\*Signals not assigned as factory default settings. The assignment may be changed by the parameter setting. For more information, refer to 5.1 Settings of Input/Output Signals.

Note 2)Wiring can be also done using DOCOM of the input signal as the GND.



### ■ Digital Input Specifications

Specifications	Details
Rated voltage	DC 12~30[V]
Precautions	<ol style="list-style-type: none"> <li>1. The input contact can be set to contact A or contact B based on the characteristics of individual signal.</li> <li>2. Each input contact can be assigned to 33 functions.</li> <li>3. For more information on signal assignment and contact change of the input contact, refer to 5.1 Settings for Input/Output Signals.</li> </ol>

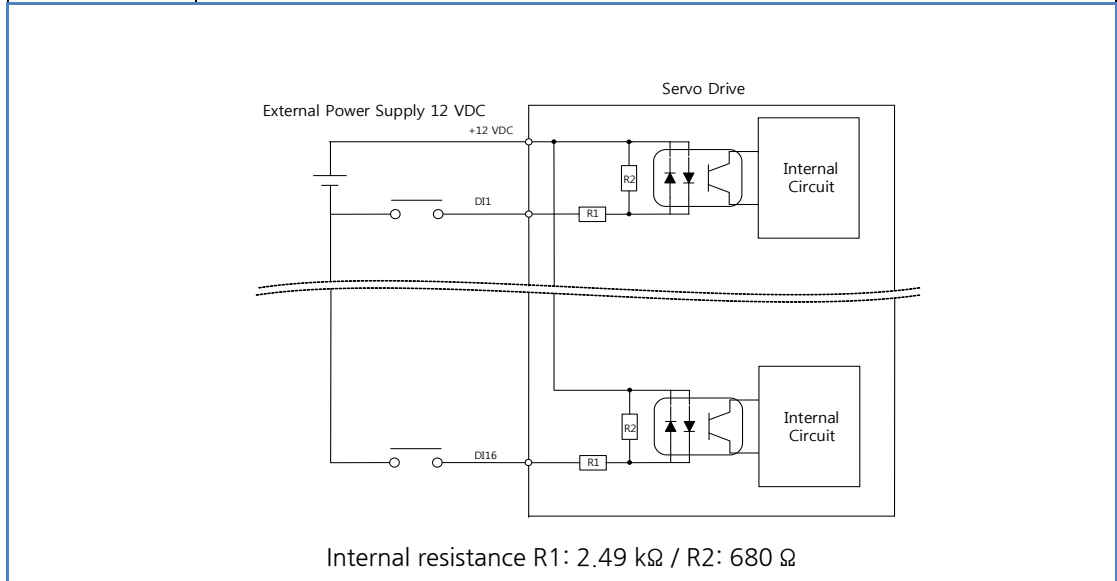

## 2.4.2 Names and Functions of Digital Output Signals

### ■ Names and Functions of Digital Output Signals (I/O Connector)

Pin Number	Name	Assignment	Description	Function
15	DO1	BRAKE	Brake	This is the control signal of a brake mounted inside or outside the motor. When the SVON contact is off, this signal is output.
16	DO2	ALARM	Servo alarm	This signal is output when a servo alarm is generated.
17	DO3	RDY	Servo ready	This signal is output when the main power is established and the preparations for servo operation are complete.
18	DO4	ZSPD	Zero speed achieved	Outputs a signal when the current speed drops below the zero speed.
25	DOCOM			Digital output common GND
	** INPOS1		Position reached 1	This signal is output when the command position has been reached. Output conditions can be set by [0x2401] and [0x2402].
	** TLMT		Torque limit	If the drive output is limited to torque limit settings, the signal is output.
	** VLMT		Speed limit	When the motor reaches the speed limit, the signal is output. The speed limit can be adjusted in [0x230D] and [0x230E].
	** INSPD		Speed reached	If the difference between command speed and current speed is below the value set in [0x2406], the signal is output.
	** WARN		Servo warning	If a warning occurs, the signal is output.
	** TGON		Rotation detection	If the motor rotates above the value set in [0x2405], this is output.

** EOS	Operation completed	When index operation is completed, the signal is output. It can be used in index operation mode.
** INPOS2	Position reached 2	This signal is output when the command position has been reached. Output conditions can be set by [0x2403].
** IOU0	Index output 0	Displays the current index number (0 - 63). It can be used in index operation mode while the indexing operation by EOE is performed.
** IOU1	Index output 1	
** IOU2	Index output 2	
** IOU3	Index output 3	
** IOU4	Index output 4	
** IOU5	Index output 5	

\*\* Unassigned signals. The assignment may be changed by the parameter setting. For more information, refer to 5.1 Settings of Input/Output Signals.

### ■ Digital Output Specifications

Specifications	Details
Rated voltage	DC 24[V] / 120[mA]
Precautions	<ol style="list-style-type: none"> <li>1. The output contact can be set to contact A or contact B based on the characteristics of individual signal.</li> <li>2. Each output contact can be assigned to 19 output functions.</li> <li>3. For more information on signal assignment and contact change of the output contact, refer to 5.1 Settings for Input/Output Signals.</li> <li>4. Overvoltages or overcurrents may damage the device because it uses an internal transistor switch.</li> </ol>

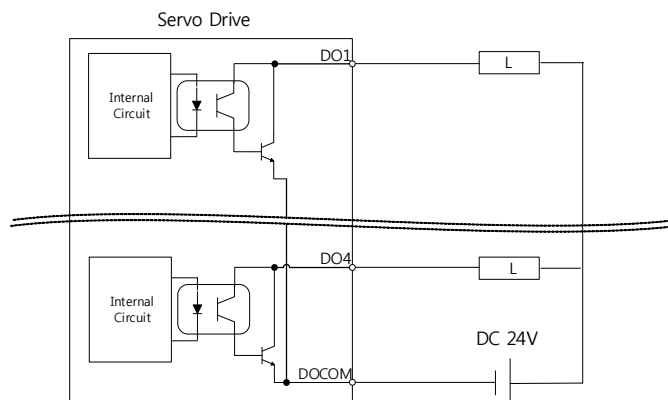

### 2.4.3 Names and Functions of Analog Input Signals

#### ■ Names and Functions of Analog Input Signals (I/O Connector)

Pin Number	Name	Description	Function
6	AI+	-5 ~ +5[V] +5 ~ -5[V] 10Vpp	Depending on the parameter setting, the function changes as follows: - Speed override: It can be used in index operation mode while the indexing operation is performed. - Speed command: It can be used in speed operation mode while the indexing operation is performed.
7	AI-		- Torque command: It can be used in torque operation mode while the indexing operation is performed. - Torque limit: It can be used in index operation mode and EtherCAT operation mode while the indexing operation is performed. You can enter a value between -10 and +10 V for AI+ and AI-.

#### ■ Analog Input Specifications

Specifications	Details
Rated voltage	Input signal differential DC -5 V - +5 V (10 Vpp)
Precautions	1. Input impedance is approx. 3.74 kΩ.

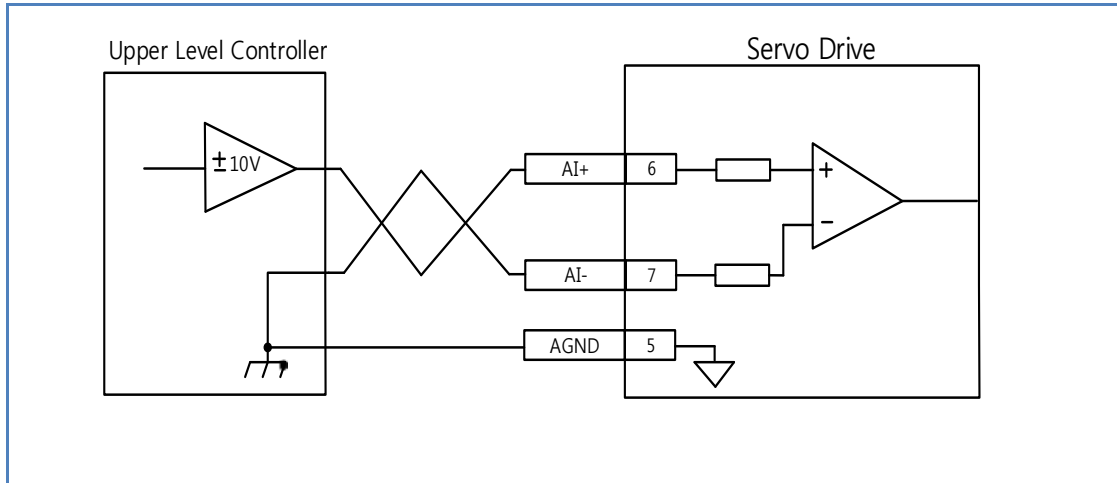

## 2.4.4 Names and Functions of Analog Output Signals

### ■ Names and Functions of Analog Output Signals

Pin Number	Name	Description	Function
8	AMON1	Analog Monitor 1	Analog monitor output (-10 V - +10V)
9	AMON2	Analog Monitor 2	Analog monitor output (-10 V - +10V)
5	AGND	AGND(0V)	Analog ground
26	AGND	AGND(0V)	Analog ground

Note 1) You can change the output variables to be monitored with analog monitor output through parameter settings.

For more information, refer to 7.5 Analog Monitor.

### ■ Analog Output Specifications

Specifications	Details
<b>Precautions</b>	<ol style="list-style-type: none"> <li>1. For more information on settings and scale adjustment of monitoring signals, refer to 7.5 Analog Monitor.</li> <li>2. The range of the analog output signal is -5 V to +5 V (10 Vpp).</li> <li>3. The resolution of the analog output signal is 12 bits.</li> <li>4. The maximum load current allowed is 2.5 mA.</li> <li>5. The stabilization time is 15 us.</li> </ol>

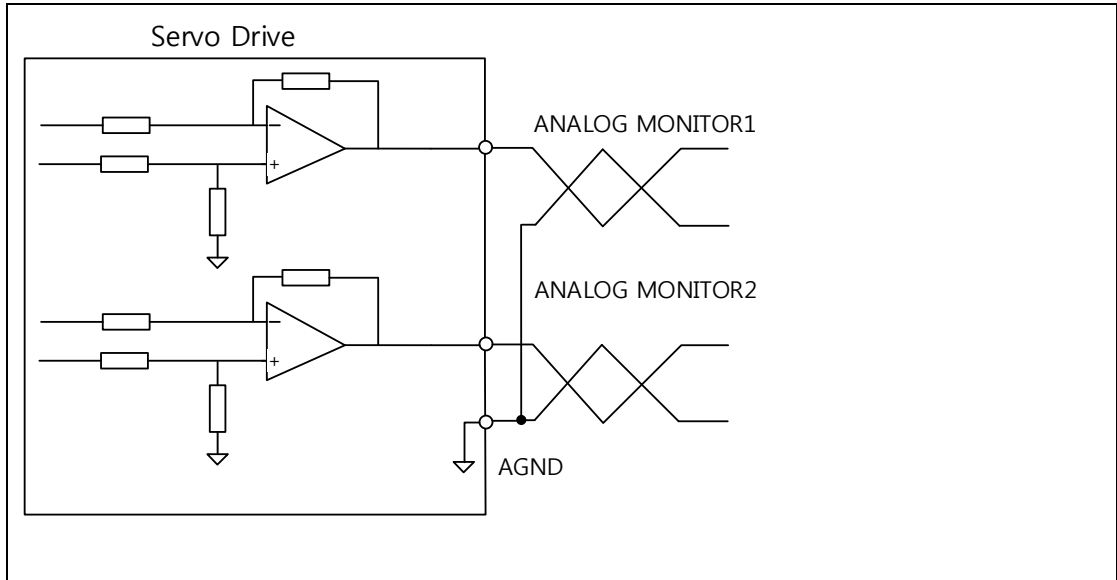

## 2.4.5 Names and Functions of Pulse Train Input Signals

### ■ Pulse Train Input Signal (I/O Connector)

Pin Number	Name	Description	Function
1	PF+		They input command pulse trains. PF+ and PF- input direct pulse trains and PR+ and PR- input inverse pulse trains.
2	PF-		
3	PR+		
4	PR-		It operates when the pulse input position has been selected in [0x3000]. You can set the position input pulse logic in [0x3003] and change the pulse input filter settings in [0x3004]. It uses a line drive method and its maximum input frequency is 4 Mpps.

### ■ Line Drive (5 V) Pulse Input

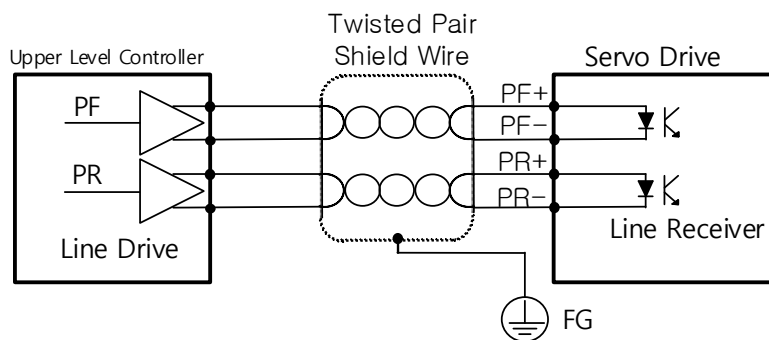

## 2.4.6 Names and Functions of Encoder Output Signals

### ■ Encoder Output Signal (I/O Connector)

Pin Number	Name	Description	Function
19	AO	Encoder A Signal	Outputs the divided encoder signal A, B, and Z phases in a line drive form. You can set the number of output pulses in [0x3006].
20	/AO		
21	BO	Encoder B Signal	
22	/BO		
23	ZO	Encoder Z Signal	
24	/ZO		



## 2.4.7 Input/Output Signal Wiring Diagram

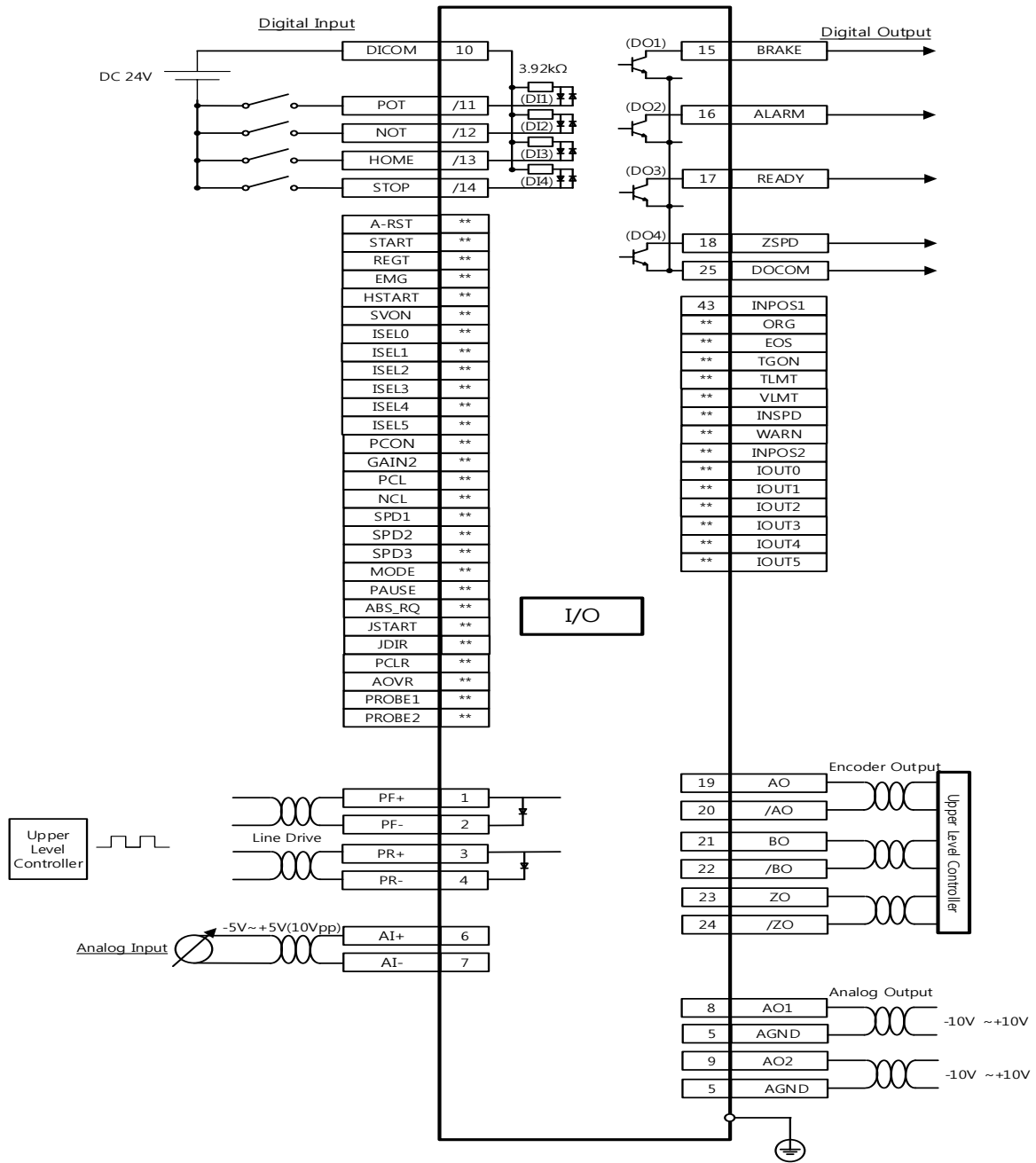

Input signals DI1 - DI4 and output signals DO1 - DO4 are factory default signals.

## 2.5 Wiring of Encoder Signals (Encoder Connector)

### ■ ENC A Connector Specifications

- Connector : 10090769-P154ALF
- Housing: 3357-9209
- Recommended cable specifications: 8P x 0.2 SQ or 8P x 24 AWG (twisted pair/shielded cable)

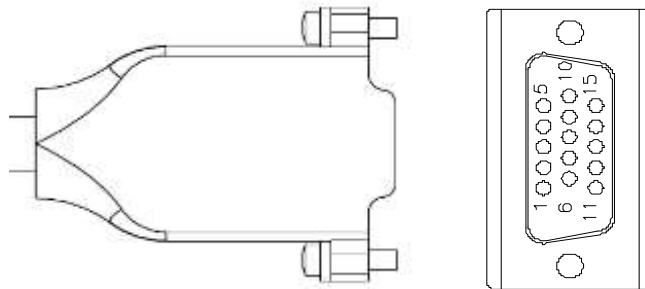

Pin#	Quad	BiSS	SSI	Endat	Tamagawa
1	Z+	N.C	N.C	N.C	N.C
2	Z-	N.C	N.C	N.C	N.C
3	GND	GND	GND	GND	GND
4	N.C	N.C	N.C	N.C	N.C
5	5V	5V	5V	5V	5V
6	GND	GND	GND	GND	GND
7	A-	SL-	DATA-	RC-/DV-	TXD-/RXD-
8	A+	SL+	DATA+	RC+/DV+	TXD+/RXD+
9	N.C	N.C	N.C	N.C	N.C
10	*MOT	*MOT	*MOT	*MOT	*MOT
11	B-	MA-	CLK-	CLK-	N.C
12	B+	MA+	CLK+	CLK+	N.C
13	N.C	N.C	N.C	N.C	N.C
14	N.C	N.C	N.C	N.C	N.C
15	N.C	N.C	N.C	N.C	N.C

■ ENC B Connector Specifications

- Connector 10090770-S154ALF

- Housing: 3357-9209

- Recommended cable specifications: 8P x 0.2 SQ or 8P x 24 AWG (twisted pair/shielded cable)

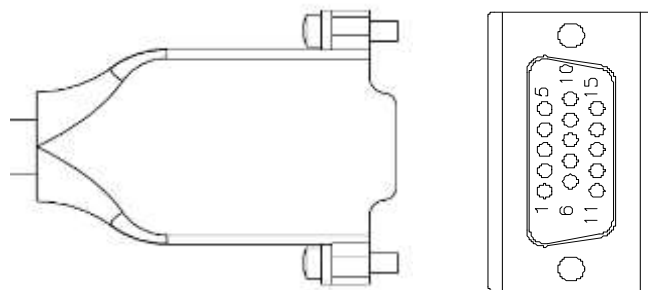

Pin#	Quad	BiSS	SSI	Endat	Tamagawa	Sin/Cos	Resolver
1	Z+	N.C	N.C	N.C	N.C	N.C	N.C
2	Z-	N.C	N.C	N.C	N.C	N.C	N.C
3	GND	GND	GND	GND	GND	GND	GND
4	N.C	N.C	N.C	N.C	N.C	SIN+	SIN+
5	5V	5V	5V	5V	5V	5V	5V
6	N.C	N.C	N.C	N.C	N.C	REF-	EXT-
7	A-	SL-	DATA-	RC-/DV-	TXD-/RXD-	N.C	N.C
8	A+	SL+	DATA+	RC+/DV+	TXD+/RXD+	N.C	N.C
9	N.C	N.C	N.C	N.C	N.C	SIN-	SIN-
10	*MOT	*MOT	*MOT	*MOT	*MOT	*MOT	*MOT
11	B-	MA-	CLK-	CLK-	N.C	N.C	N.C
12	B+	MA+	CLK+	CLK+	N.C	N.C	N.C
13	N.C	N.C	N.C	N.C	N.C	REF+	EXT+
14	N.C	N.C	N.C	N.C	N.C	COS-	COS-
15	N.C	N.C	N.C	N.C	N.C	COS+	COS+

## 2.6 Wiring for Safety Function Signals

### ■ STO Connector Specifications

- PLUG: IPD1-03-D-K
- Recommended cable specifications: 20 AWG - 24 AWG

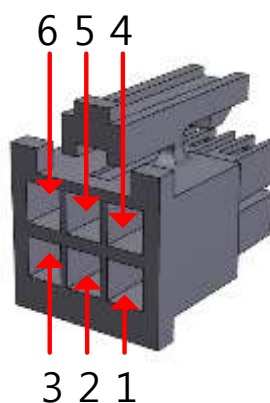

Pin Number	Name	Function
1	COM	Common(24V GND)
2	STO2	Blocks the current (torque) applied to the motor when the signal is off.
3	STO1	Blocks the current (torque) applied to the motor when the signal is off.
4	V-	DC -12 V (for bypass wiring)
5	V+	DC +12 V (for bypass wiring)
6	V+	DC +12 V (for bypass wiring)

## 2.6.1 Example of Connecting Safety Function Signals

**⚠ Caution**

Rated voltage is DC 12 - 30 V.

With the contacts of STO1 and STO2 off, the motor output current is blocked.

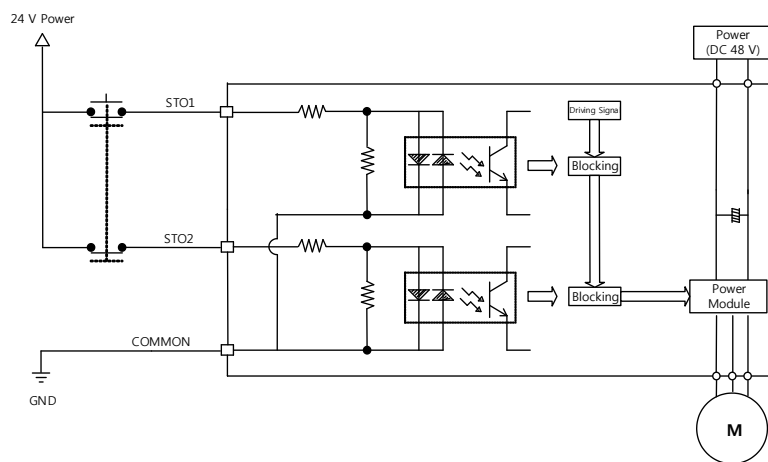

## 2.6.2 Bypass Wiring of Safety Function Signals

In the case of the Phoenix series, internal wiring for the bypass function is provided for user convenience if the user does not use the STO function.

As indicated in the figure below, V+ can be connected to STO1 and STO2 and V- can be connected to Common to bypass the safety function signals. Never use this power (+12 V, -12 V) except for this purpose.

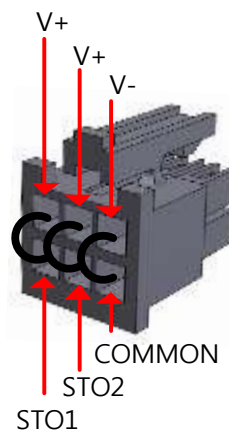

## 2.7 Brake Connectors

■ Brake Connector Specifications

- PLUG: IPD1-02-D-K

- Recommended cable specifications: 20 AWG - 24 AWG

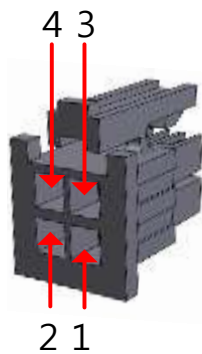

Pin Number	Name	Function
1	24V	Brake 24V Input
2	BRK+	Brake 24V Output
3	BRK-	Brake (1A)
4	24G	24V Return

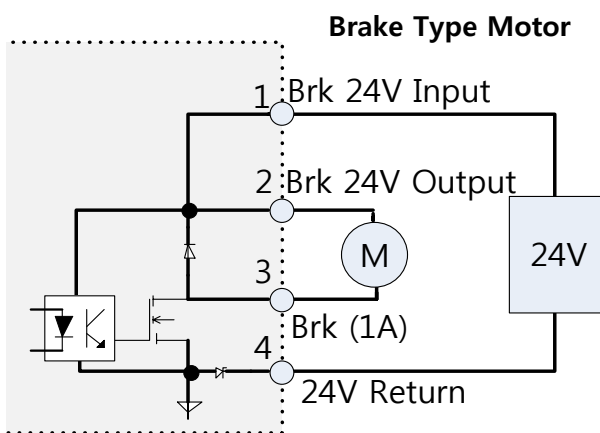









Input	State	Function
BRAKE	HI	Deactivates the brake depending on brake TR ON (Unlock)
	LO	Operates the brake depending on brake TR OFF (Lock)

## 2.8 Wiring for EtherCAT Communication Signals

### 2.8.1 Names and Functions of EtherCAT Communication Signals

■ EtherCAT IN and EtherCAT OUT Connector

Pin Number	Signal Name	Line color
1	TX/RX0 +	White/Orange 
2	TX/RX0 -	Orange 
3	TX/RX1+	White/Green 
4	TX/RX2 -	Blue 
5	TX/RX2 +	White/Blue 
6	TX/RX1 -	Green 
7	TX/RX3 +	White/Brown 
8	TX/RX3 -	Brown 
Plate		Shield

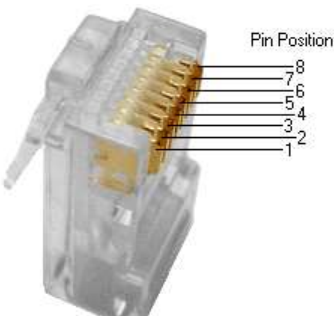

Note 1) EtherCAT only uses signals from No. 1, 2, 3, and 6.

## 2.8.2 Example of Drive Connection

The following figure shows the connection between a master and slave using EtherCAT communication. This is an example of a connection by topology of the basic line type.

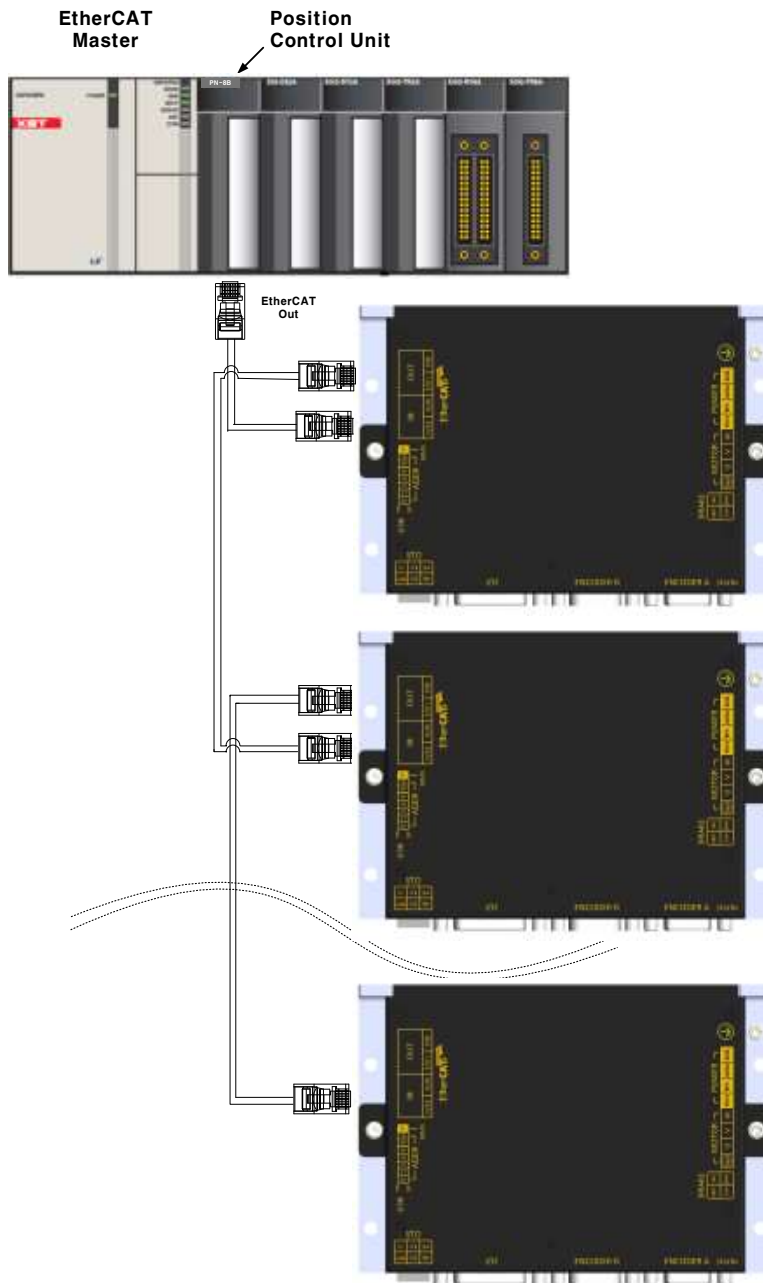



### 3. EtherCAT Communication

EtherCAT stands for Ethernet for Control Automation Technology. It is a communication method for masters and slaves that uses Real-Time Ethernet, developed by the German company BECKHOFF and managed by the EtherCAT Technology Group (ETG).

The basic concept of EtherCAT communication is that, when a DataFrame sent from a master passes through a slave, the slave inputs the received data to the DataFrame as soon as it receives the data.

EtherCAT uses a standard Ethernet frame compliant with IEEE802.3. Therefore, based on the Ethernet 100BASE-TX, the cable can be extended up to 100 m, and up to 65,535 nodes can be connected. In addition to this, when using a separate Ethernet switch, you can interconnect with the commonly used TCP/IP.

#### 3.1 Structure of CANopen over EtherCAT

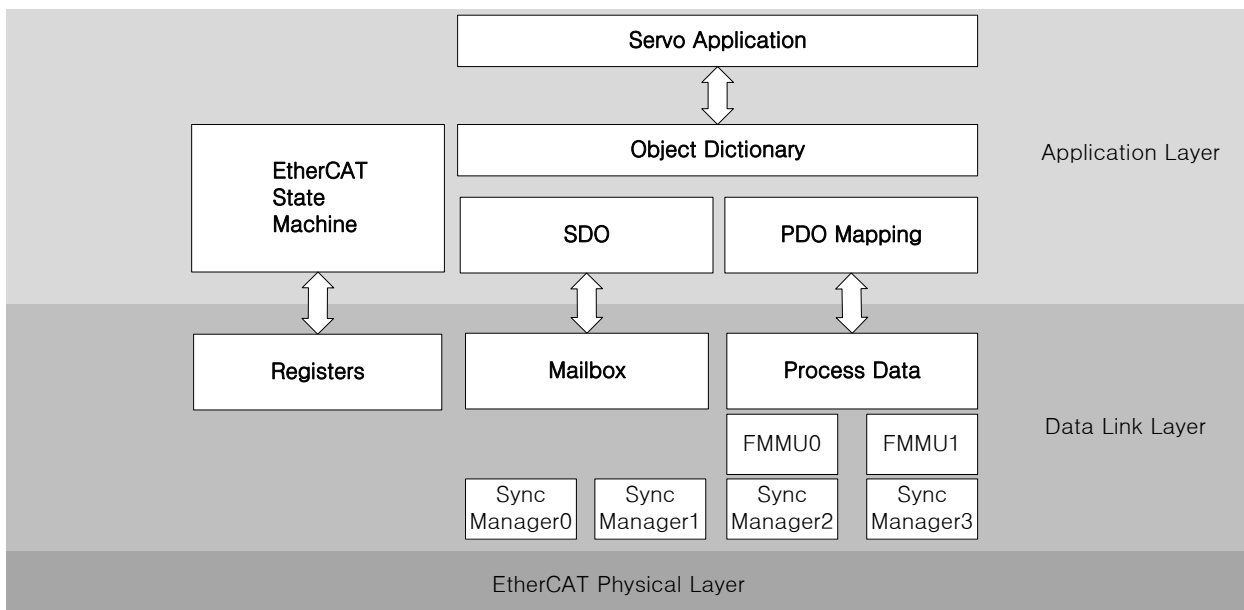

This drive supports a CiA 402 drive profile. The Object Dictionary in the application layer includes the application data and PDO (Process Data Object) mapping information from the process data interface and application data.

The PDO can be freely mapped, and the content of the process data is defined by PDO mapping.

The data mapped to the PDO is periodically exchanged (read and written) between an upper level controller and a slave by process data communication; the mailbox communication is performed aperiodically; and all of the parameters defined in the Object Dictionary are accessible.

### 3.1.1 EtherCAT State Machine

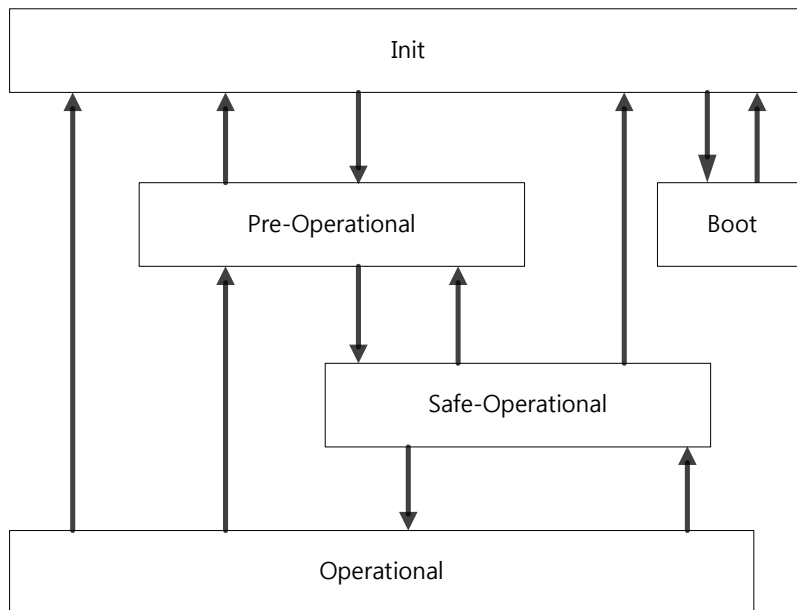

The EtherCAT drive has 5 states as shown above, and a state transition is achieved by an upper level controller (master).

State	Description
Boot	A state for firmware updates. Only mailbox communication using the FoE (File access over EtherCAT) protocol is available. The drive can transit to the Boot state only when in the Init state.
Init	Initializes the communication state. Unable to perform mailbox or process data communication.
Pre-Operational	Mailbox communication is possible.
Safe-Operational	Mailbox communication is possible and PDO can be transmitted. PDO cannot be received. The process data of the drive can be passed to an upper level controller.
Operational	Mailbox communication is possible and PDO can be transmitted and received. The process data can be properly exchanged between the drive and the upper level controller, so the drive can be normally operated.

## 3.2 Status LED

The LEDs on the EtherCAT ports of this drive indicate the states of the EtherCAT communications and errors, as shown in the following figure. There are 3 green LEDs, L/A0, L/A1, and RUN, and 1 red LED, ERR.

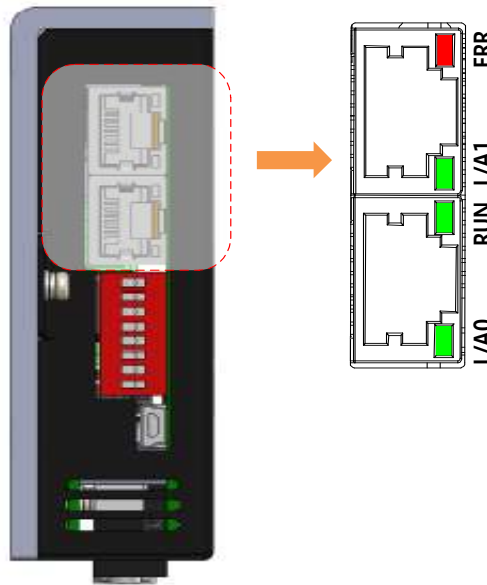



### ■ L/A0, L/A1 (Link Activity) LED

The L/A0 LED and L/A1 LED indicate the status of the EtherCAT IN and EtherCAT OUT communication ports, respectively. The following table outlines what each LED state indicates.

LED status	Description
OFF	Not connected for communication.
Flickering	 Connected, and communication is enabled.
ON	Connected, but communication is disabled.



■ RUN LED

The RUN LED indicates in which state the drive is in the EtherCAT State Machine.

LED status	Description
OFF	The drive is in the Init state.
Blinking	The drive is in the Pre-Operational state. 
Single Flash	The drive is in the Safe-Operational state. 
ON	The drive is in the Operational state.

■ ERR LED

The ERR LED indicates the error status of the EtherCAT communication. The following table outlines what each LED state indicates.

LED status	Description
OFF	Indicates the EtherCAT communication is in a normal state without any error.
Blinking	Indicates that the drive has received a command from the EtherCAT master instructing it to perform a setting, which is not feasible in its present state, or to perform an impossible state transition. 
Single Flash	A DC PLL Sync error occurred. 

Double Flash	A Sync Manager Watchdog error occurred.
ON	A servo alarm of the drive occurred.



### 3.3 PDO Assignments

The EtherCAT uses the Process Data Object (PDO) to perform real-time data transfers. There are two types of PDOs: RxPDO receives data transferred from the upper level controller, and TxPDO sends the data from the drive to the upper level controller.

This drive uses the objects of 0x1600 to 0x1603 and 0x1A00 to 0x1A03 to assign the RxPDO and the TxPDO, respectively. Up to 10 objects can be assigned to each PDO. You can check the PDO assignment attribute of each object to see if it can be assigned to the PDO.

The diagram below shows the PDO assignment:

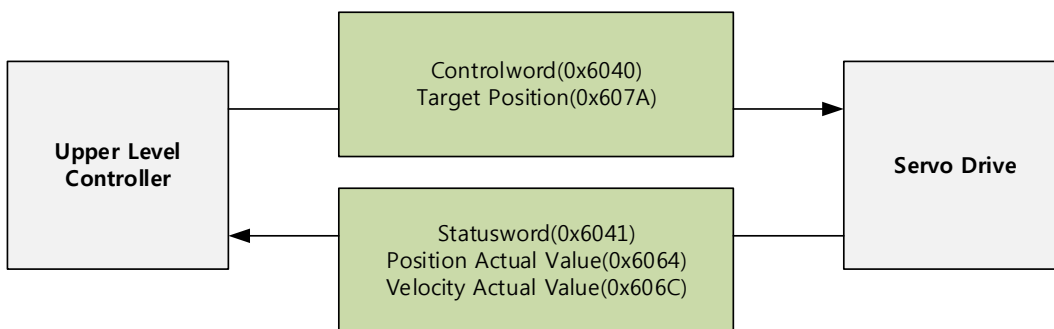

This is an example when assigning the Controlword and the Target Position with the RxPDO (0x1600).

Index	SubIndex	Name	Data Type
0x6040	0x00	Controlword	UINT
0x607A	0x00	Target Position	DINT

The setting values of the DRxPDO (0x1600) are as follows:

SubIndex	Settings
----------	----------

0	0x02 (2 values assigned)		
	Bit 31~16(Index)	Bit 15~8(Sub index)	Bit 7~0(Bit size)
1	0x6040	0x00	0x10
2	0x607A	0x00	0x20

This is an example when assigning the Statusword, the Actual Position Value, and the Actual Velocity Value with the TxPDO (0x1A00).

Index	SubIndex	Name	Data Type
0x6041	0x00	Statusword	UINT
0x6064	0x00	Actual Position Value	DINT
0x606C	0x00	Actual Velocity Value	DINT

The TxPDO (0x1A00) settings are as follows:



SubIndex	Settings		
0	0x03 (3 values assigned)		
	Bit 31~16(Index)	Bit 15~8(Sub index)	Bit 7~0(Bit size)
1	0x6041	0x00	0x10
2	0x6064	0x00	0x20
3	0x606C	0x00	0x20

The Sync Manager can be composed of multiple PDOs. The Sync Manager PDO Assign Object (RxPDO:0x1C12, TxPDO:0x1C13) indicates the relationship between the SyncManager and the PDO.

The following figure shows an example of SyncManager PDO mapping:

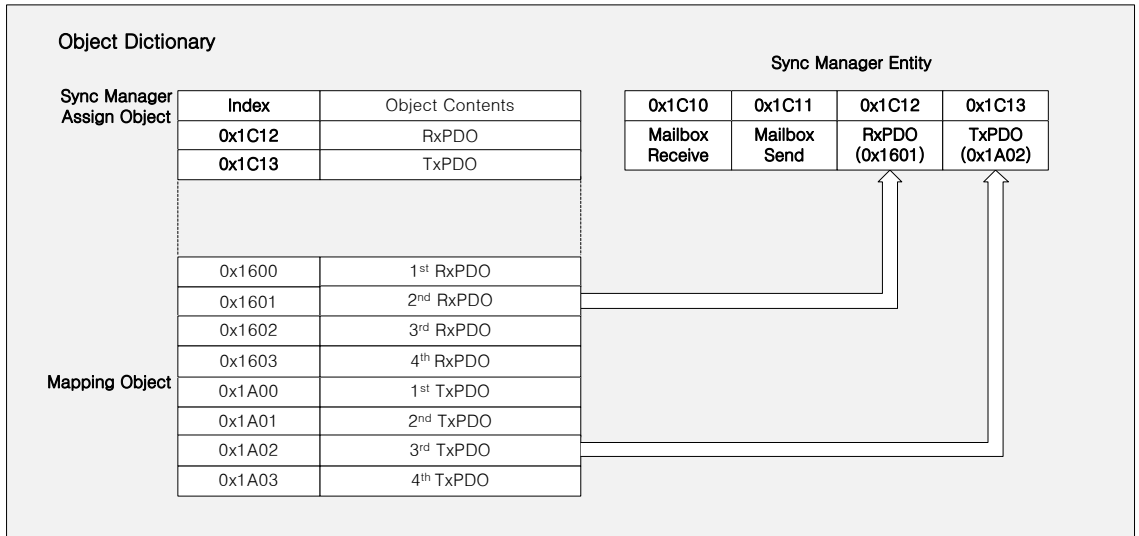

■ PDO Mapping

The following tables list the PDO mappings set by default. These settings are defined in the EtherCAT Slave Information file (XML file).

1<sup>st</sup> PDO Mapping:

RxPDO (0x1600)	Controlword (0x6040)	Target Torque (0x6071)	Target Position (0x607A)	Operation Mode (0x6060)	Touch Probe Function (0x60B8)					
TxPDO (0x1A00)	Statusword (0x6041)	Actual Torque Value (0x6077)	Actual Position Value (0x6064)	Actual Position Error Value (0x60F4)	Digital Input (0x60FD)	Drive Mode Display (0x6061)	Command Speed (0x2601)	Drive Speed (0x2600)	Touch Probe Status (0x60B9)	Touch Probe 1 Forward Position Value (0x60BA)

2<sup>nd</sup> PDO Mapping:

RxPDO (0x1600)	Controlword (0x6040)	Target Position (0x607A)
TxPDO (0x1A00)	Statusword (0x6041)	Actual Position Value (0x6064)

3<sup>rd</sup> PDO Mapping:

RxPDO (0x1600)	Controlword (0x6040)	Target Speed (0x60FF)
TxPDO (0x1A00)	Statusword (0x6041)	Actual Position Value (0x6064)

4<sup>th</sup> PDO Mapping:

RxPDO (0x1600)	Controlword (0x6040)	Target Torque (0x6071)
TxPDO (0x1A00)	Statusword (0x6041)	Actual Position Value (0x6064)

### 3.4 Synchronization Using the DC (Distributed Clock)

The Distributed Clock (DC) synchronizes EtherCAT communication. The master and slave share a reference clock (system time) for synchronization, and the slave synchronizes its applications with the Sync0 event generated by the reference clock.

The following synchronization modes exist in this drive. You can change the mode with the sync control register.

(1) Free-run Mode:

In Free-run mode, it operates each cycle independent of the communication cycle and master cycle.

(2) DC Synchronous Mode:

In DC Synchronous mode, the Sync0 event from the EtherCAT master synchronizes the drive. Please use this mode for more precise synchronous control.

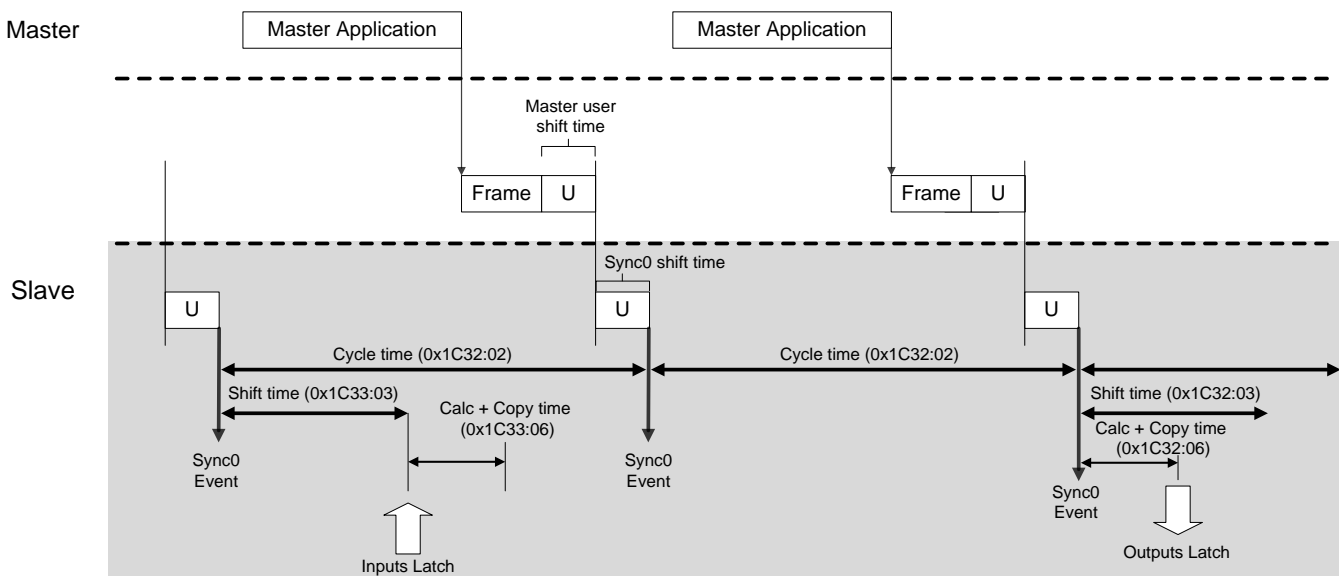



## 3.5 Emergency Messages

Emergency messages are passed to the master via mailbox communication when a servo alarm occurs in the drive. Emergency messages may not be sent in the event of communication failure.

Emergency messages consist of 8-byte data.

9	0	1	2	3	4	5	6	7
Details	Emergency error code (0xFF00)		Error register (0x1001)	Reserved	Unique field for each manufacturer			
					Servo alarm code		Reserved	

# 4. CiA402 Drive Profile

## 4.1 State machine

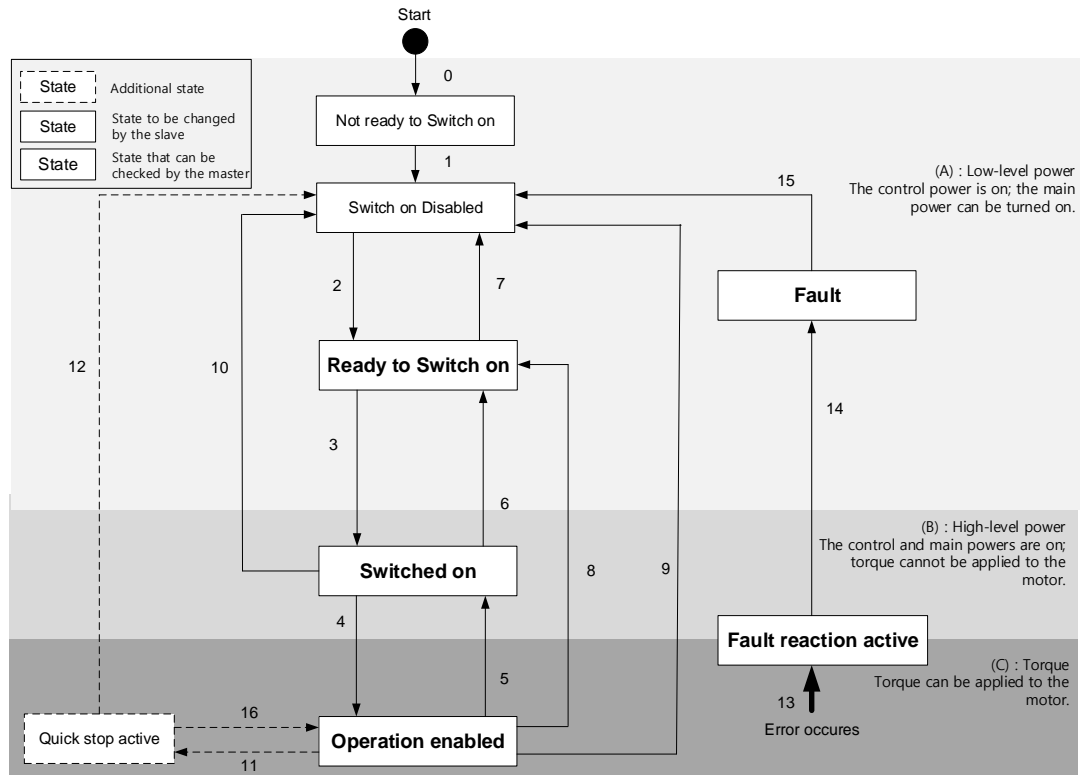

State	Description
Not ready to switch on	Reset is in progress by control power on.
Switch on disabled	Initialization completed, but the main power cannot be turned on.
Ready to switch on	The main power can be turned on and the drive function is disabled.
Switched on	The main power is turned on and the drive function is disabled.
Operation enabled	The drive function is enabled, and the servo is on.
Quick Stop active	Quick stop function is in operation.
Fault reaction active	A servo alarm occurred causing a relevant sequence to be processed.
Fault	Servo alarm is activated.

■ State Machine Control Commands

The state of the State Machine can be switched by bit setting combinations of the Controlword (0x6040) , as described in the table below:

Command	bits of the Controlword (0x6040)					State Machine switching
	Bit 7	Bit 3	Bit 2	Bit 1	Bit 0	
Shutdown	x	x	1	1	0	2, 6, 8
Switch on	x	0	1	1	1	3
Switch on + Enable operation	x	1	1	1	1	3 + 4
Disable voltage	x	x	x	0	x	7, 9, 10,12
Quick stop	x	x	0	1	x	7, 10,11
Disable operation	x	0	1	1	1	5
Enable operation	x	1	1	1	1	4, 16
Fault reset	0 → 1	x	x	x	x	15

■ Statusword Bit Names (0x6041)

You can check the state of the State Machine by bit combinations of the Statusword (0x6041), as described in the table below:

Command	bits of the Statusword (0x6041)						
	Bit 6	Bit 5	Bit 4	Bit 3	Bit 2	Bit 1	Bit 0
Not ready to switch on	0	0	x	0	0	0	0
Switch on disabled	1	1	x	0	0	0	0
Ready to switch on	0	1	x	0	0	0	1
Switched on	0	1	x	0	0	1	1
Operation enabled	0	1	x	0	1	1	1
Fault reaction active	0	1	x	1	1	1	1
Fault	0	1	x	1	0	0	0

Bit No.	Data Description	Note
0	Ready to switch on	For more information, refer to 11.5 CiA402 Objects.
1	Switched on	
2	Operation enabled	
3	Fault	
4	Voltage enabled	

5	Quick stop
6	Switched on disabled
7	Warning
8	-
9	Remote
10	Target reached
11	Internal limit active
12	Operation mode specific
13	
14	ABS position valid
15	Drive specific

## 4.2 Operation Modes

This drive supports the following operation modes (0x6060):

- Profile Position Mode(PP)
- Homing Mode(HM)
- Profile Velocity Mode(PV)
- Profile Torque Mode(PT)
- Cyclic Synchronous Position Mode(CSP)
- Cyclic Synchronous Velocity Mode(CSV)
- Cyclic Synchronous Torque Mode(CST)

Drive functions supported for each mode are listed in the table below:

Function	Operation Modes			
	CSP PP	CSV PV	CST PT	HM
Electric Gear	O	O	O	O
Speed feedforward	O	X	X	OX
Torque feedforward	O	O	X	O

Position command filter	O	X	X	OX
Real-time gain adjustment	O	O	O	O
Notch filter	O	O	O	O
Disturbance observer	O	O	X	O

Note 2) For HM mode, the control mode is internally switched; thus, the function of speed feedforward and/or position command filter may or may not be applied, depending on the operation condition.

■ Related Objects

Index	Sub Index	Name	Variable type	Accessibility	PDO Assignment	Unit
0x6060	-	Modes of Operation	SNIT	RW	Yes	-
0x6061	-	Modes of Operation Display	SNIT	RO	Yes	-
0x6502	-	Supported Drive Modes	UDINT	RO	No	-

## 4.3 Position Control Modes

### 4.3.1 Cyclic Synchronous Position Mode

Cyclic Synchronous Position (CSP) mode receives the target position (0x607A) that is renewed at every PDO update cycle from the upper level controller to control the position.

In this mode, the controller is able to calculate the velocity offset (0x60B1) and the torque offset (0x60B2) that corresponds to the speed and torque feedforwards respectively, and pass them to the drive.

The block diagram of CSP mode is as follows:

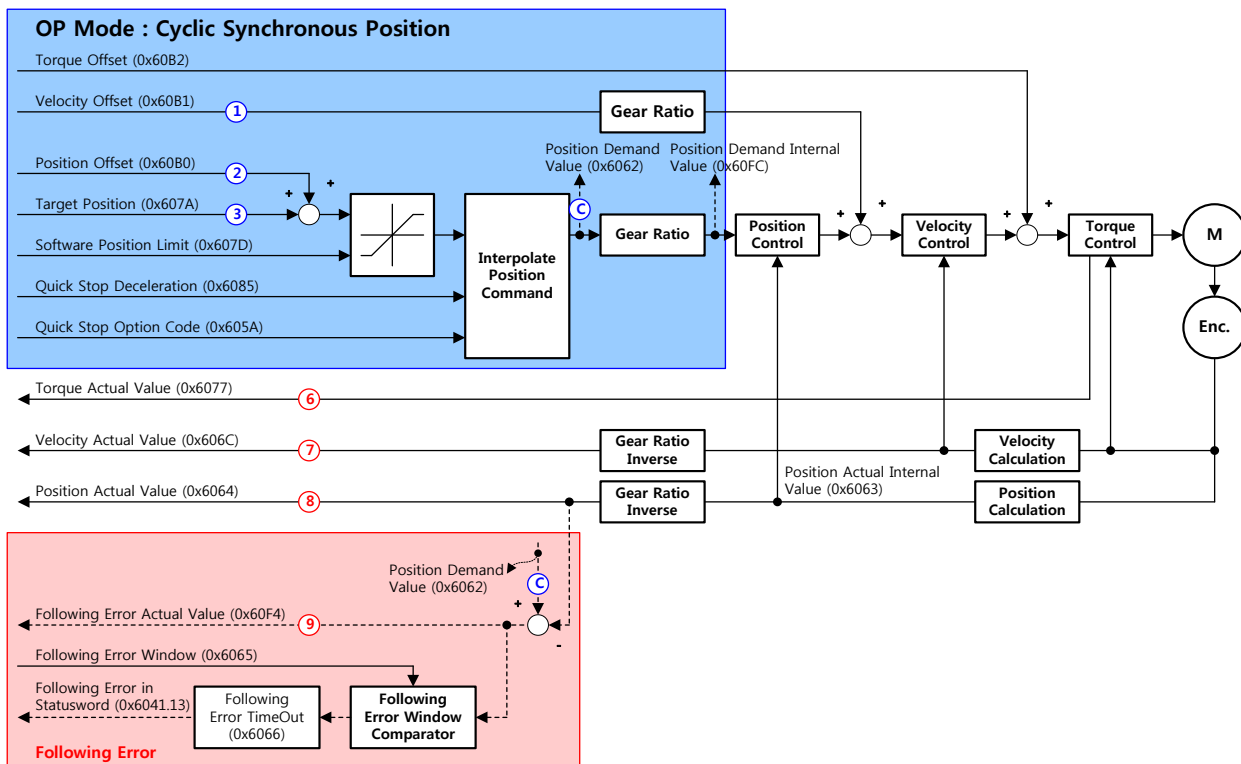

■ Related Objects

Index	Sub Index	Name	Variable type	Accessibility	PDO Assignment	Unit
0x6040	-	Controlword	UINT	RW	Yes	-
0x6041	-	Statusword	UINT	RO	Yes	-
0x607A	-	Target Position	DINT	RW	Yes	UU
0x607D	-	Software Position Limit	-	-	-	-
	0	Number of entries	USINT	RO	No	-
	1	Min position limit	DINT	RW	No	UU
	2	Max position limit	DINT	RW	No	UU
0x6084	-	Profile Deceleration	UDINT	RW	No	UU/s <sup>2</sup>
0x6085	-	Quick Stop Deceleration	UDINT	RW	No	UU/s <sup>2</sup>
0x60B0	-	Position Offset	DINT	RW	Yes	UU
0x60B1	-	Velocity Offset	DINT	RW	Yes	UU/s
0x60B2	-	Torque Offset	INT	RW	Yes	0.1%
0x6062	-	Position Demand Value	DINT	RO	Yes	UU
0x60FC	-	Position Demand Internal Value	DINT	RO	Yes	pulse
0x606C	-	Velocity Actual Value	DINT	RO	Yes	UU/s
0x606D	-	Velocity Window	UINT	RW	No	UU/s
0x606E	-	Velocity Window Time	UINT	RW	No	ms
0x6077	-	Torque Actual Value	INT	RO	Yes	0.1%
0x606C	-	Velocity Actual Value	DINT	RO	Yes	UU/s
0x6064	-	Position Actual Value	DINT	RO	Yes	UU
0x6063	-	Position Actual Internal Value	DINT	RO	Yes	pulse

Internal Block Diagram of CSP Mode

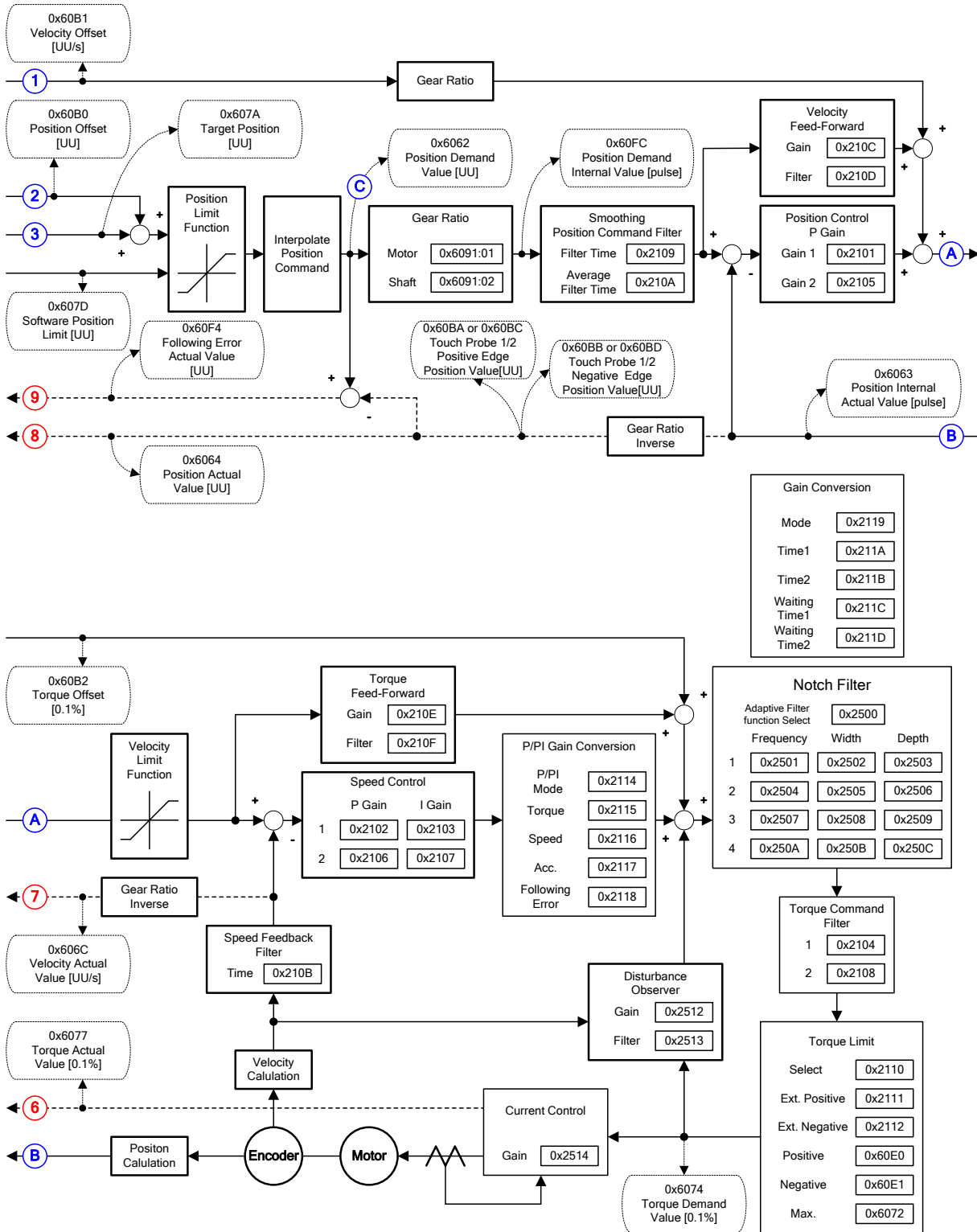



### 4.3.2 Profile Position Mode

Unlike CSP mode, which receives the target position that is renewed at every PDO update cycle from the upper level controller, in Profile Position (PP) mode, the drive generates a position profile internally to operate up to the target position (0x607A) using the profile velocity (0x6081), acceleration (0x6083), and deceleration (0x6084).

The block diagram of PP mode is as follows:

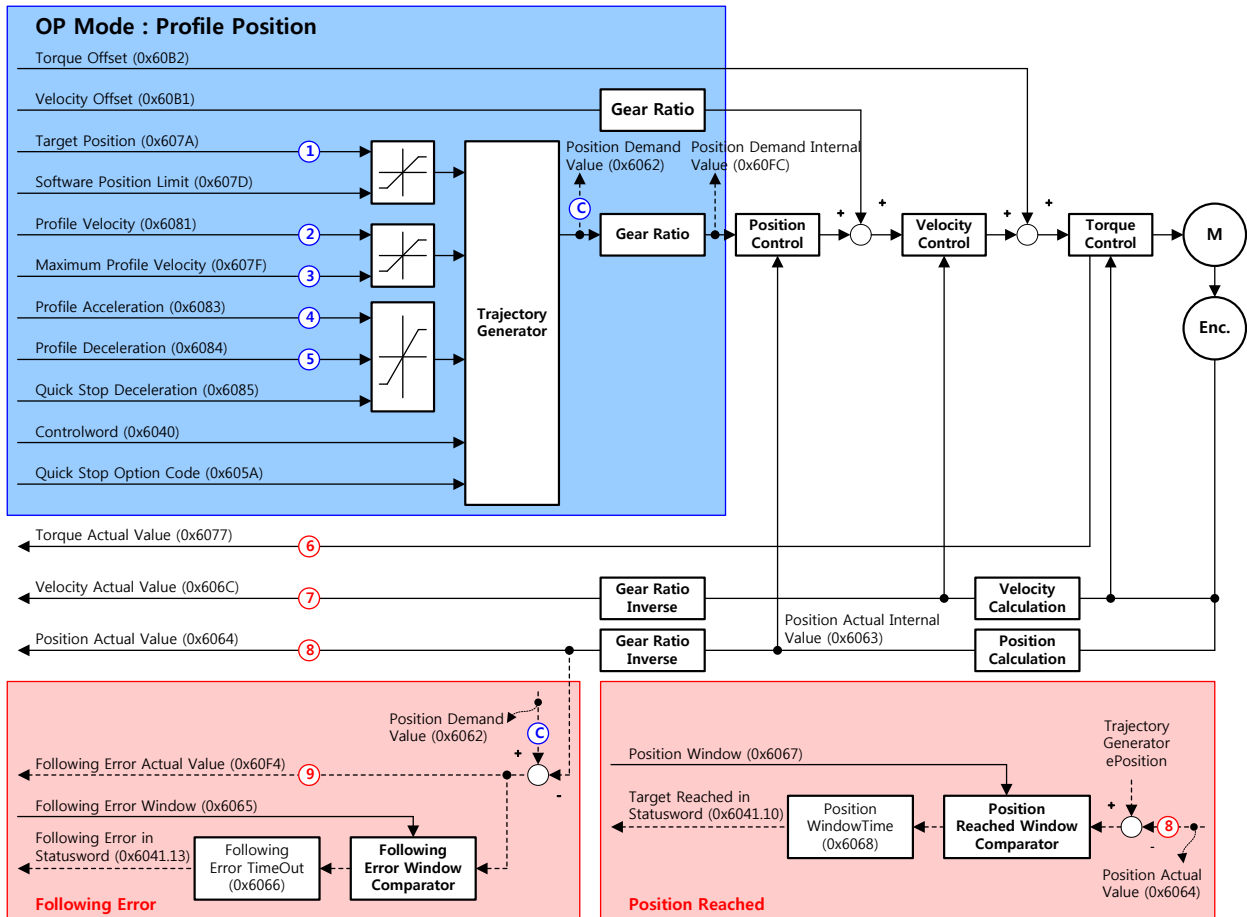

### ■ Related Objects

Index	Sub Index	Name	Variable type	Accessibility	PDO Assignment	Unit
0x6040	-	Controlword	UINT	RW	Yes	-
0x6041	-	Statusword	UINT	RO	Yes	-
0x607A	-	Target Position	DINT	RW	Yes	UU
0x607D	-	Software Position Limit	-	-	-	-
	0	Number of entries	USINT	RO	No	-
	1	Min position limit	DINT	RW	No	UU
	2	Max position limit	DINT	RW	No	UU
0x607F	-	Maximum Profile Velocity	UDINT	RW	Yes	UU/s
0x6081	-	Profile Velocity	UDINT	RW	No	UU/s
0x6083	-	Profile Acceleration	UDINT	RW	No	UU/s <sup>2</sup>
0x6084	-	Profile Deceleration	UDINT	RW	No	UU/s <sup>2</sup>
0x6085	-	Quick Stop Deceleration	UDINT	RW	No	UU/s <sup>2</sup>
0x60B1	-	Velocity Offset	DINT	RW	Yes	UU/s
0x60B2	-	Torque Offset	INT	RW	Yes	0.1%
0x6062	-	Position Demand Value	DINT	RO	Yes	UU
0x60FC	-	Position Demand Internal Value	DINT	RO	Yes	pulse
0x606C	-	Velocity Actual Value	DINT	RO	Yes	UU/s
0x606D	-	Velocity Window	UINT	RW	No	UU/s
0x606E	-	Velocity Window Time	UINT	RW	No	ms
0x6077	-	Torque Actual Value	INT	RO	Yes	0.1%
0x606C	-	Velocity Actual Value	DINT	RO	Yes	UU/s
0x6064	-	Position Actual Value	DINT	RO	Yes	UU
0x6063	-	Position Actual Internal Value	DINT	RO	Yes	pulse

### Internal Block Diagram of PP Mode

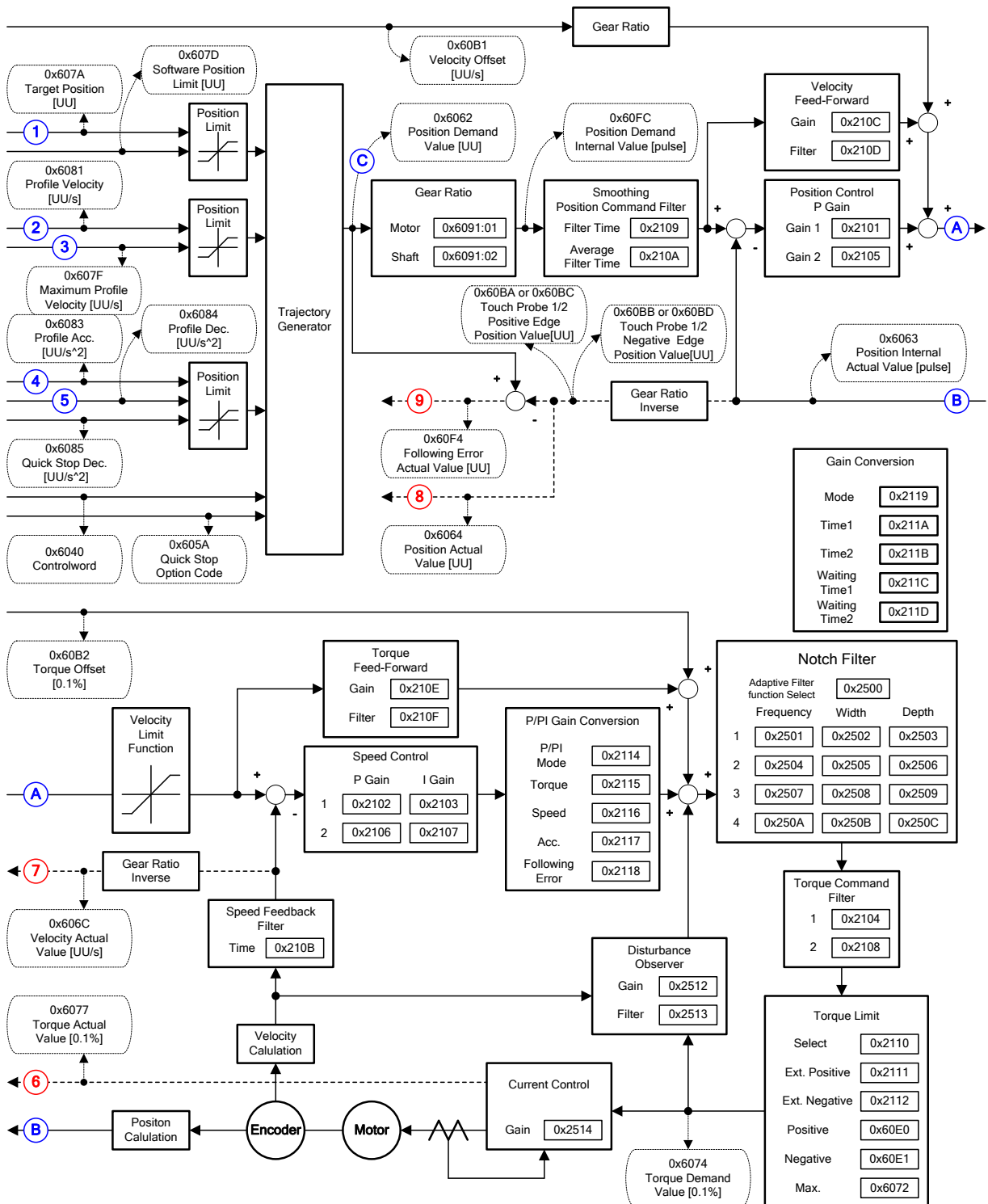

You can use the following three position commands in Profile Position Mode:

- Single set point

After reaching the target position, the drive sends a completion signal to the upper level controller and receives a new command.

- Change immediately

When it receives a new position command while driving to the target position, it drives to the new position regardless of the existing target position.

- Set of Set point

When it receives a new position command while driving to the target position, it subsequently drives to the new target position after driving to the existing target position.

The three methods mentioned above can be set by the combination of the New set point bit (Controlword, 0x6040.4), the Change set immediately bit (Controlword, 0x6040.5), and the Change set point bit (Controlword, 0x6040.9).

#### ■ Single Set Point Driving Procedure

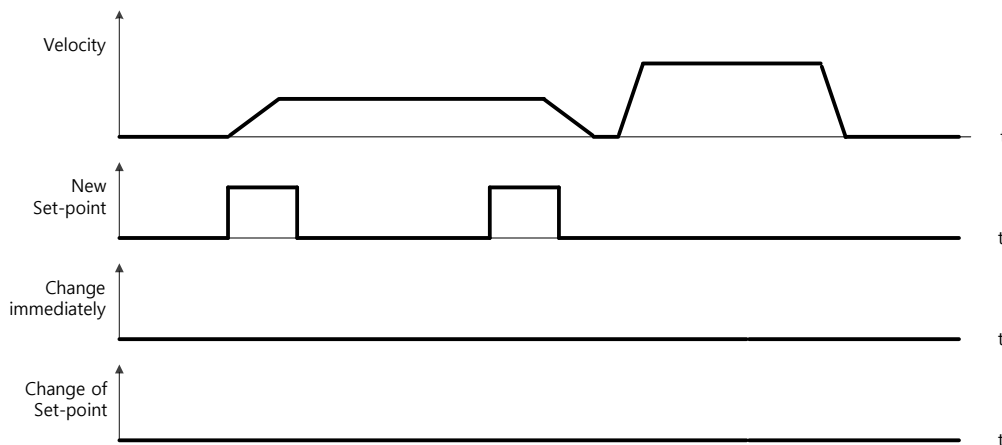

- (1) Specify the target position (0x607A).
- (2) Set the New set point bit to 1 and the Change set immediately bit to 0 to request the position operation.
- (3) The drive notifies the operator of its arrival at the target position with the Target reached bit (Statusword, 0x6041.10). The drive can suspend where it is or perform a new position operation if it receives the New set point bit.

■ Change Immediately Driving Procedure

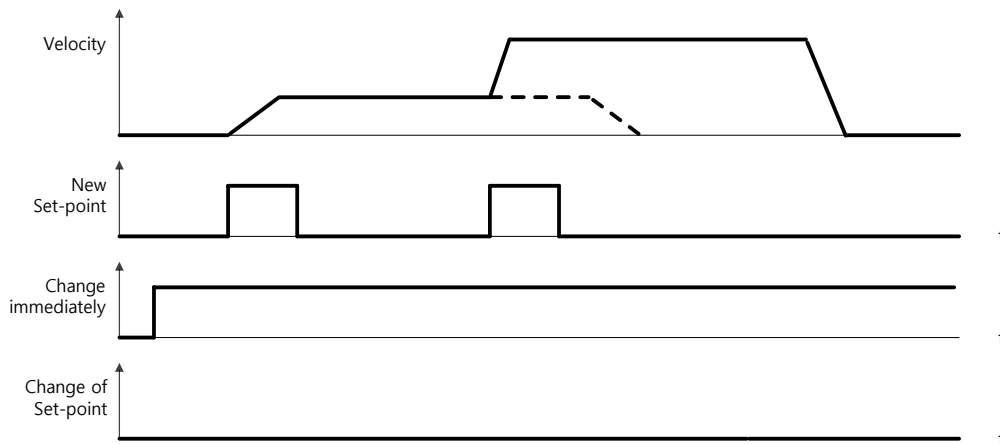

- (1) Specify the target position (0x607A).
- (2) Set the New set point bit to 1 and the Change set immediately bit to 1 to request the position operation.
- (3) You can begin a new position operation (New set point) regardless of the previous target position. The drive immediately moves to the new position.
- (4) The drive notifies the operator of its arrival at the target position with the Target reached bit (Statusword, 0x6041.10).

■ Set of Set Point Driving Procedure

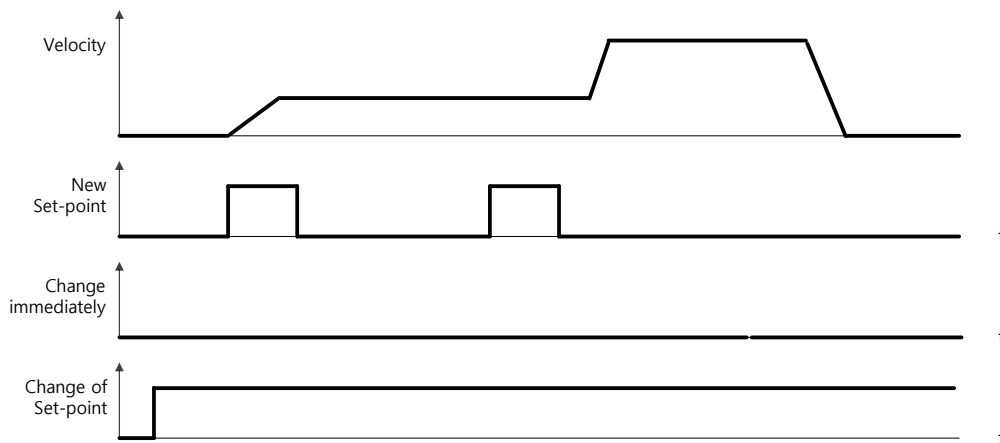

- (1) Specify the target position (0x607A).
- (2) Set the New set point bit to 1 and the Change of set point bit to 1 to request the position operation.

- (3) After reaching the previous target position, the drive begins to move to the new position (New set point).
- (4) The drive notifies the operator of its arrival at the target position with the Target reached bit (Statusword, 0x6041.10).

## 4.4 Velocity Control Modes

### 4.4.1 Cyclic Synchronous Velocity Mode

Cyclic Synchronous Velocity (CSV) mode receives the target velocity (0x60FF) that is renewed at every PDO update cycle from the upper level controller to control the velocity.

This mode allows the upper level controller to calculate the torque offset (0x60B2) that corresponds to the torque feedforward and pass it to the drive.

The block diagram of the CSV mode is shown below.

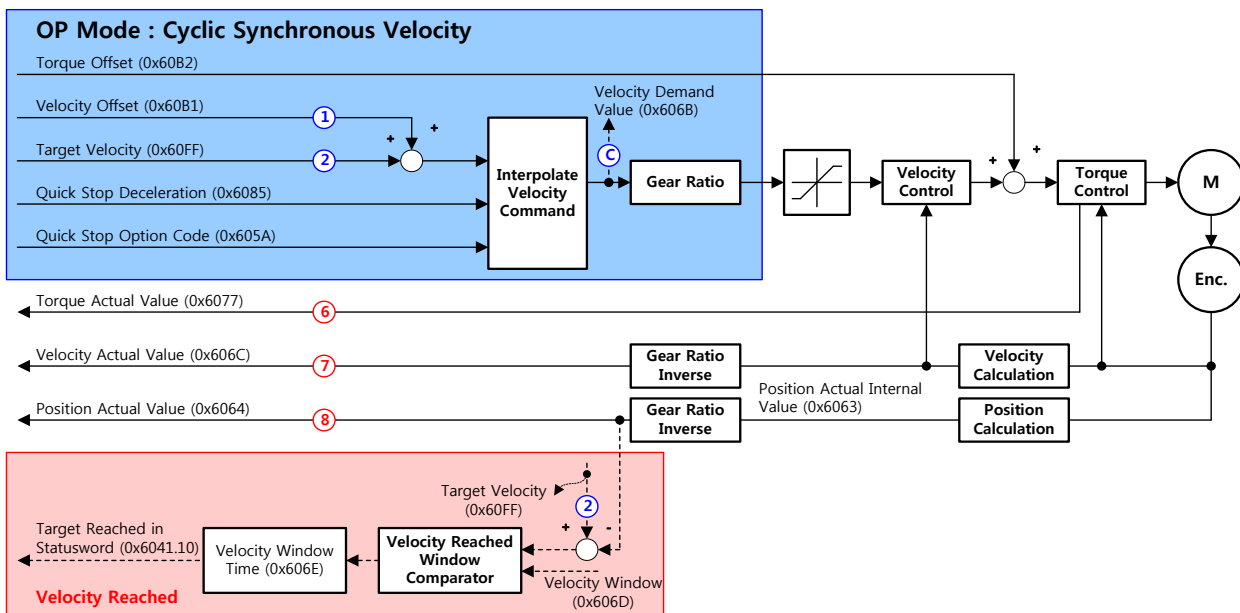

#### ■ Related Objects

Index	Sub Index	Name	Variable type	Accessibility	PDO Assignment	Unit
0x6040	-	Controlword	UINT	RW	Yes	-
0x6041	-	Statusword	UINT	RO	Yes	-
0x60FF	-	Target Velocity	DINT	RW	Yes	UU/s
0x6084	-	Profile Deceleration	UDINT	RW	No	UU/s <sup>2</sup>

0x6085	-	Quick Stop Deceleration	UDINT	RW	No	UU/s <sup>2</sup>
0x60B1	-	Velocity Offset	DINT	RW	Yes	UU/s
0x60B2	-	Torque Offset	INT	RW	Yes	0.1%
0x606B	-	Velocity Demand Value	DINT	RO	Yes	UU
0x606C	-	Velocity Actual Value	DINT	RO	Yes	UU/s
0x606D	-	Velocity Window	UINT	RW	No	UU/s
0x606E	-	Velocity Window Time	UINT	RW	No	ms
0x6077	-	Torque Actual Value	INT	RO	Yes	0.1%
0x606C	-	Velocity Actual Value	DINT	RO	Yes	UU/s
0x6064	-	Position Actual Value	DINT	RO	Yes	UU
0x6063	-	Position Actual Internal Value	DINT	RO	Yes	pulse

Internal Block Diagram of CSV Mode

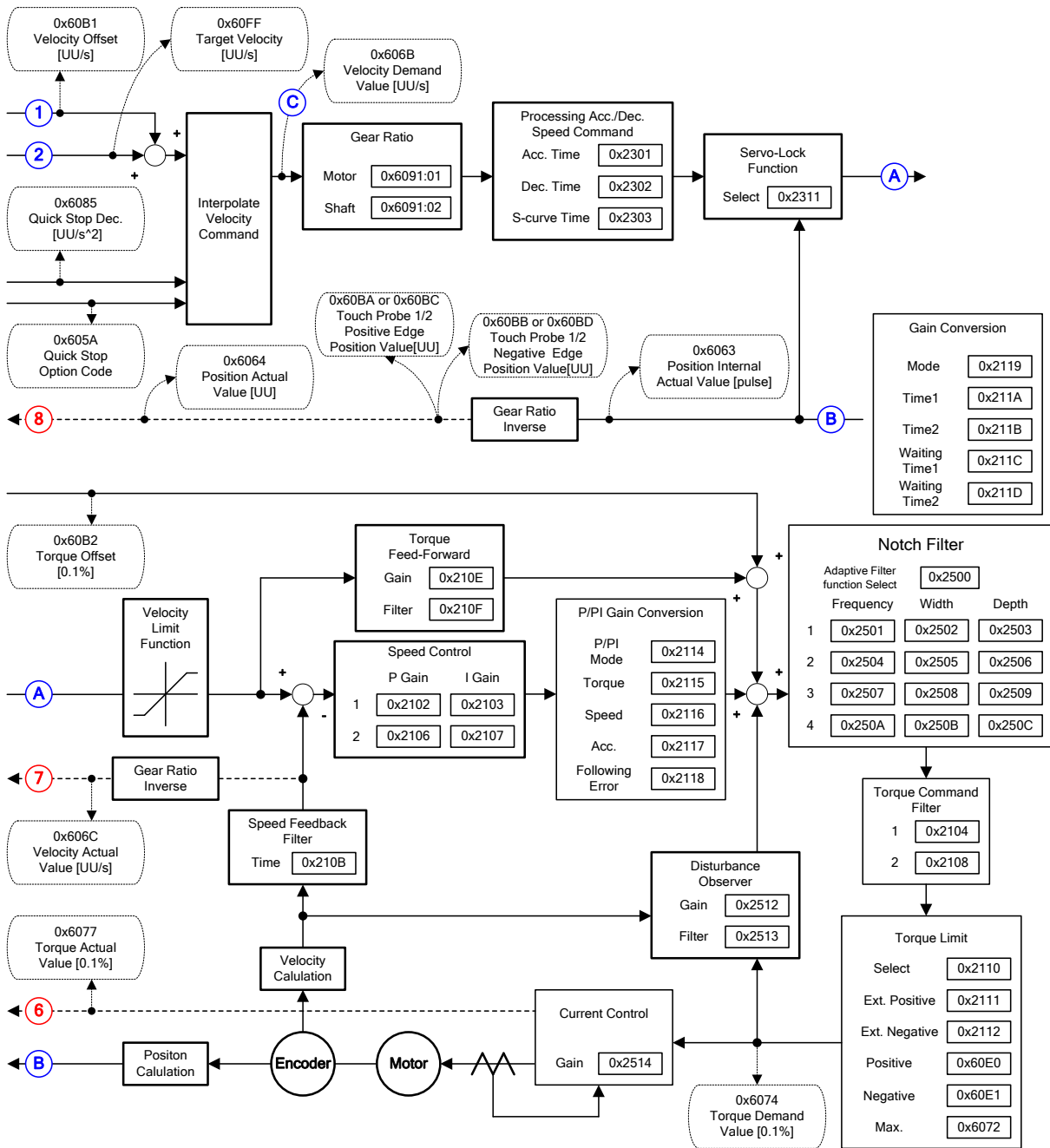



### 4.4.2 Profile Velocity Mode

Unlike CSV mode, which receives the target velocity that is renewed at every PDO update cycle from the upper level controller, in Profile Velocity (PV) mode, the drive generates a velocity profile internally up to the target velocity (0x60FF) using the profile acceleration (0x6083) and deceleration (0x6084) in order to control its velocity.

At this time, the max. profile velocity (0x607F) limits the maximum velocity.

The block diagram of the PV mode is shown below.

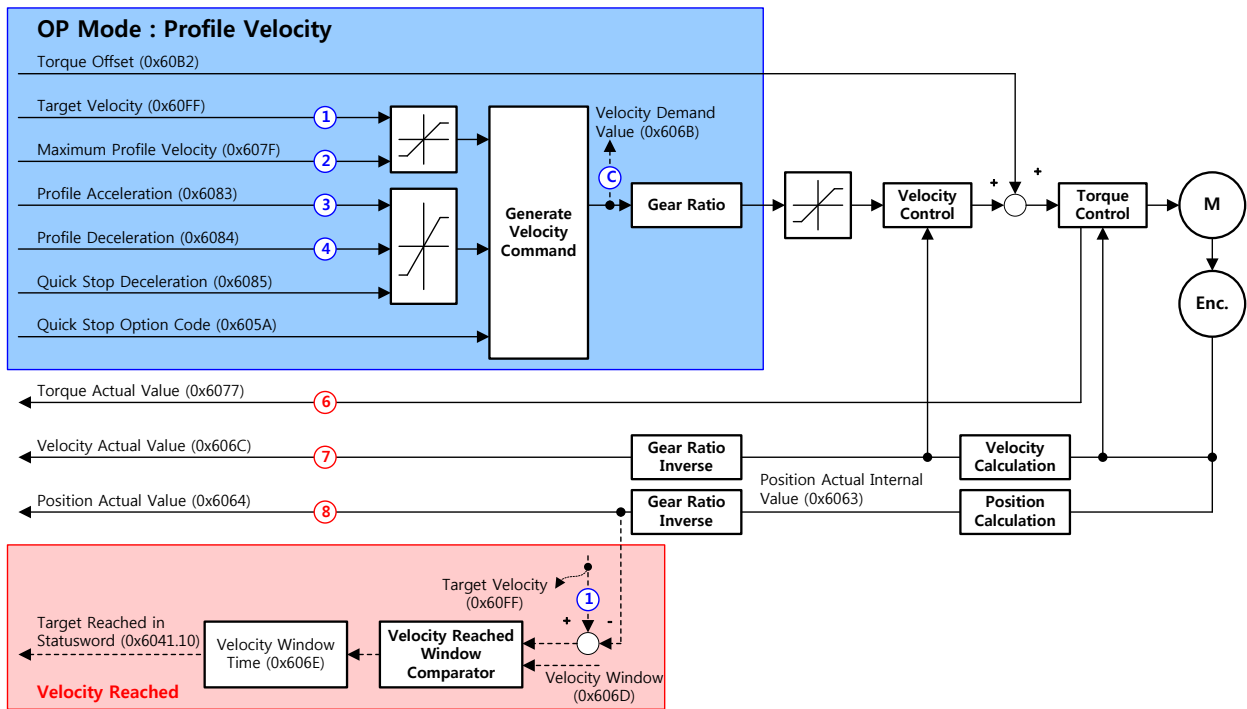

### ■ Related Objects

Index	Sub Index	Name	Variable type	Accessibility	PDO Assignment	Unit
0x6040	-	Controlword	UINT	RW	Yes	-
0x6041	-	Statusword	UINT	RO	Yes	-
0x60FF	-	Target Velocity	DINT	RW	Yes	UU/s
0x607F	-	Maximum Profile Velocity	UDINT	RW	Yes	UU/s
0x6083	-	Profile Acceleration	UDINT	RW	No	UU/s <sup>2</sup>
0x6084	-	Profile Deceleration	UDINT	RW	No	UU/s <sup>2</sup>
0x6085	-	Quick Stop Deceleration	UDINT	RW	No	UU/s <sup>2</sup>
0x605A	-	Quick Stop Option Code	INT	RW	No	-
0x60B1	-	Velocity Offset	DINT	RW	Yes	UU/s
0x60B2	-	Torque Offset	INT	RW	Yes	0.1%
0x606B	-	Velocity Demand Value	DINT	RO	Yes	UU/s
0x606C	-	Velocity Actual Value	DINT	RO	Yes	UU/s
0x606D	-	Velocity Window	UINT	RW	No	UU/s
0x606E	-	Velocity Window Time	UINT	RW	No	ms
0x6077	-	Torque Actual Value	INT	RO	Yes	0.1%
0x606C	-	Velocity Actual Value	DINT	RO	Yes	UU/s
0x6064	-	Position Actual Value	DINT	RO	Yes	UU
0x6063	-	Position Actual Internal Value	DINT	RO	Yes	pulse

Internal Block Diagram of PV Mode

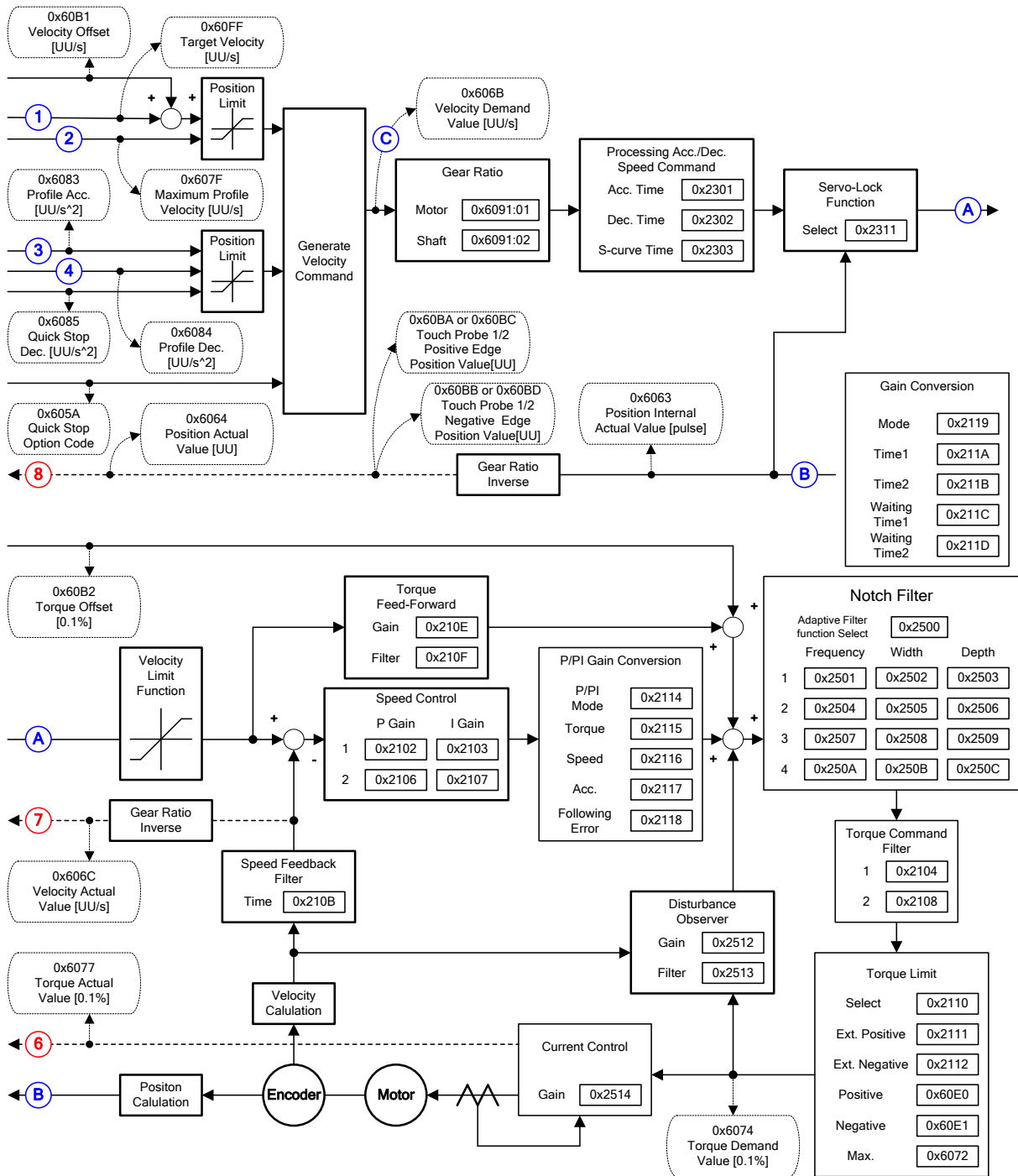

## 4.5 Torque Control Modes

### 4.5.1 Cyclic Synchronous Torque Mode

Cyclic Synchronous Torque (CST) mode receives the target torque (0x6071) that is renewed at every PDO update cycle from the upper level controller to control the torque.

This mode allows the upper level controller to calculate the torque offset (0x60B2) that corresponds to the torque feedforward and pass it to the drive.

The block diagram of the CST mode is shown below.

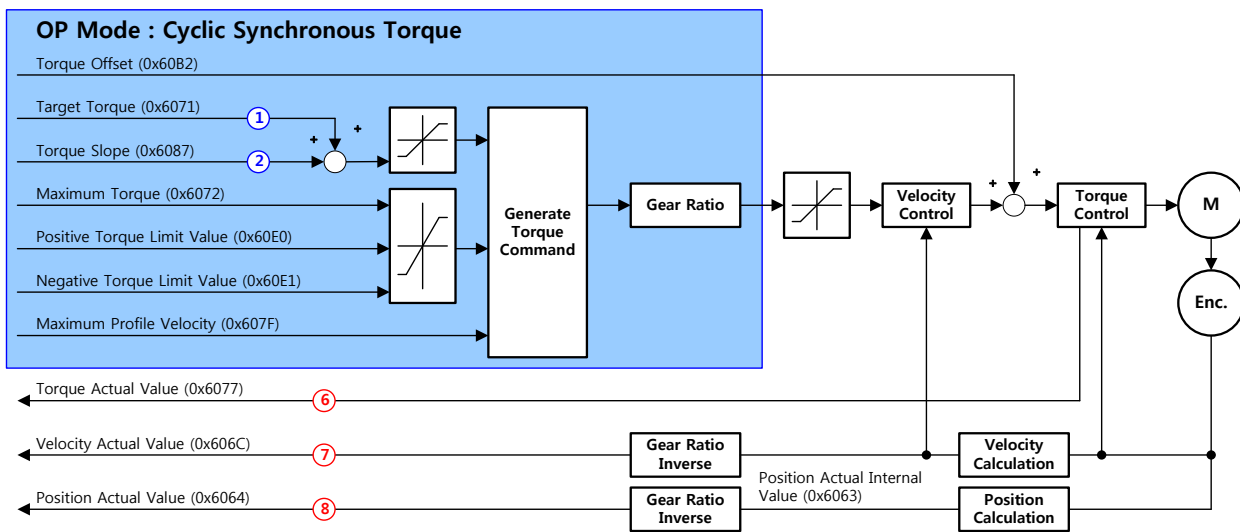

#### ■ Related Objects

Index	Sub Index	Name	Variable type	Accessibility	PDO Assignment	Unit
0x6040	-	Controlword	UINT	RW	Yes	-
0x6041	-	Statusword	UINT	RO	Yes	-
0x6071	-	Target Velocity	INT	RW	Yes	0.1%
0x6072	-	Maximum Torque	UINT	RW	Yes	0.1%
0x607F	-	Maximum Profile Velocity	UDINT	RW	Yes	UU/s
0x60E0	-	Positive Torque Limit Value	UINT	RW	Yes	0.1%
0x60E1	-	Negative Torque Limit Value	UINT	RW	Yes	0.1%
0x60B2	-	Torque Offset	INT	RW	Yes	0.1%
0x6074	-	Torque Demand Value	INT	RO	Yes	0.1%
0x606C	-	Velocity Actual Value	DINT	RO	Yes	UU/s

0x606D	-	Velocity Window	UINT	RW	No	UU/s
0x606E	-	Velocity Window Time	UINT	RW	No	ms
0x6077	-	Torque Actual Value	INT	RO	Yes	0.1%
0x606C	-	Velocity Actual Value	DINT	RO	Yes	UU/s
0x6064	-	Position Actual Value	DINT	RO	Yes	UU
0x6063	-	Position Actual Internal Value	DINT	RO	Yes	pulse

Internal Block Diagram of CST Mode

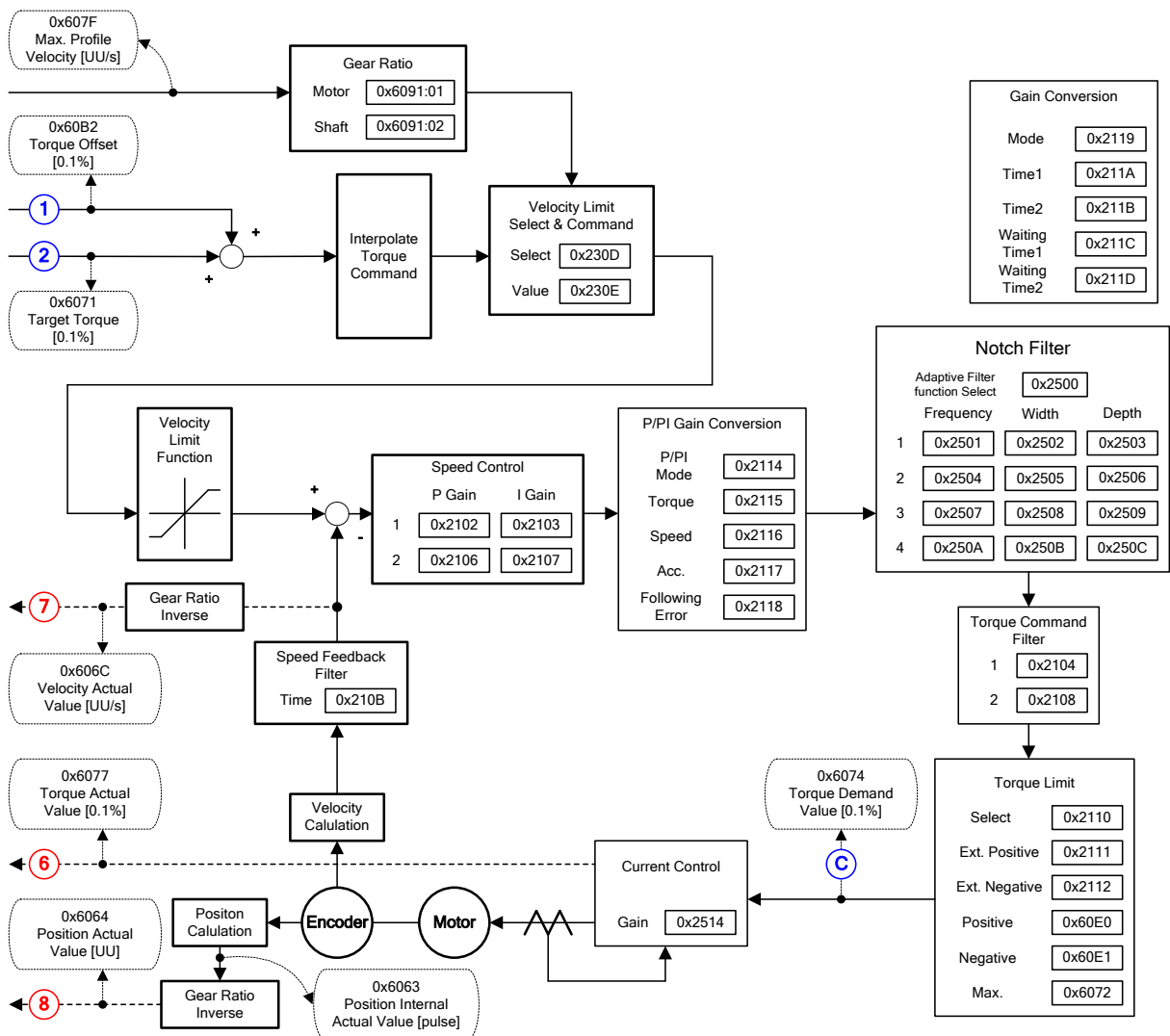

## 4.5.2 Profile Torque Mode

Unlike CST mode, which receives the target torque that is renewed at every PDO update cycle from the upper level controller, in Profile Torque (PT) mode, the drive generates a torque profile internally up to the target torque (0x6071) by the torque slope (0x6087) in order to control its torque.

At this moment, the torque applied to the motor is limited depending on the Forward/Reverse Torque Limit Value (0x60E0 and 0x60E1) and the Maximum Torque (0x6072) based on its driving direction.

The block diagram of the PT mode is shown below.

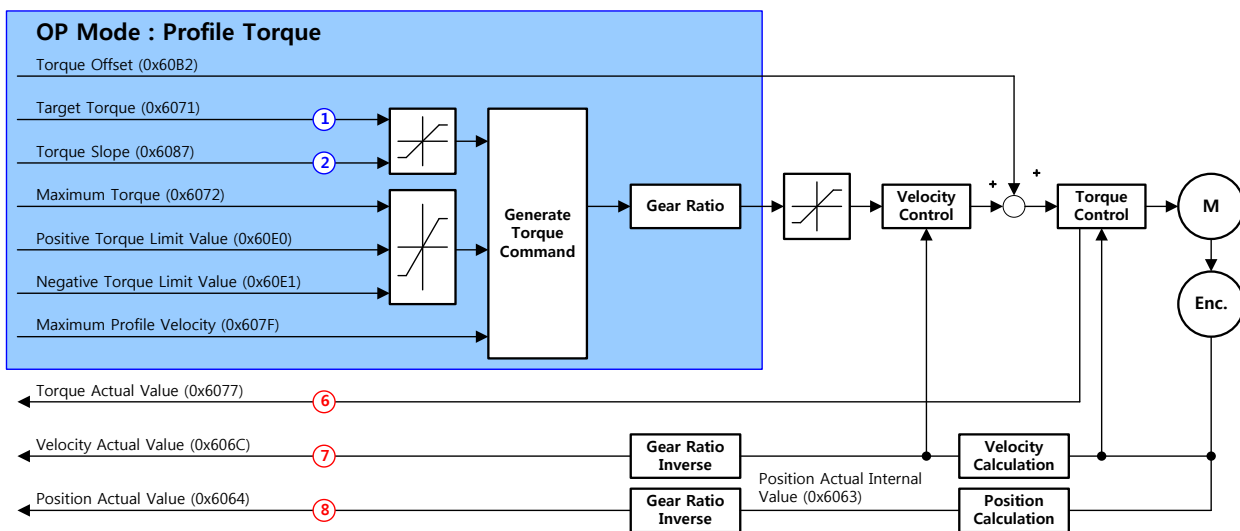

### ■ Related Objects

Index	Sub Index	Name	Variable type	Accessibility	PDO Assignment	Unit
0x6040	-	Controlword	UINT	RW	Yes	-
0x6041	-	Statusword	UINT	RO	Yes	-
0x6071	-	Target Velocity	INT	RW	Yes	0.1%
0x6072	-	Maximum Torque	UINT	RW	Yes	0.1%
0x607F	-	Maximum Profile Velocity	UDINT	RW	Yes	UU/s
0x6087	-	Torque Slope	UDINT	RW	Yes	0.1%/s
0x60E0	-	Positive Torque Limit Value	UINT	RW	Yes	0.1%
0x60E1	-	Negative Torque Limit Value	UINT	RW	Yes	0.1%
0x60B2	-	Torque Offset	INT	RW	Yes	0.1%

0x6074	-	Torque Demand Value	INT	RO	Yes	0.1 %
0x606C	-	Velocity Actual Value	DINT	RO	Yes	UU/s
0x606D	-	Velocity Window	UINT	RW	No	UU/s
0x606E	-	Velocity Window Time	UINT	RW	No	ms
0x6077	-	Torque Actual Value	INT	RO	Yes	0.1 %
0x606C	-	Velocity Actual Value	DINT	RO	Yes	UU/s
0x6064	-	Position Actual Value	DINT	RO	Yes	UU
0x6063	-	Position Actual Internal Value	DINT	RO	Yes	pulse

Internal Block Diagram of PT Mode

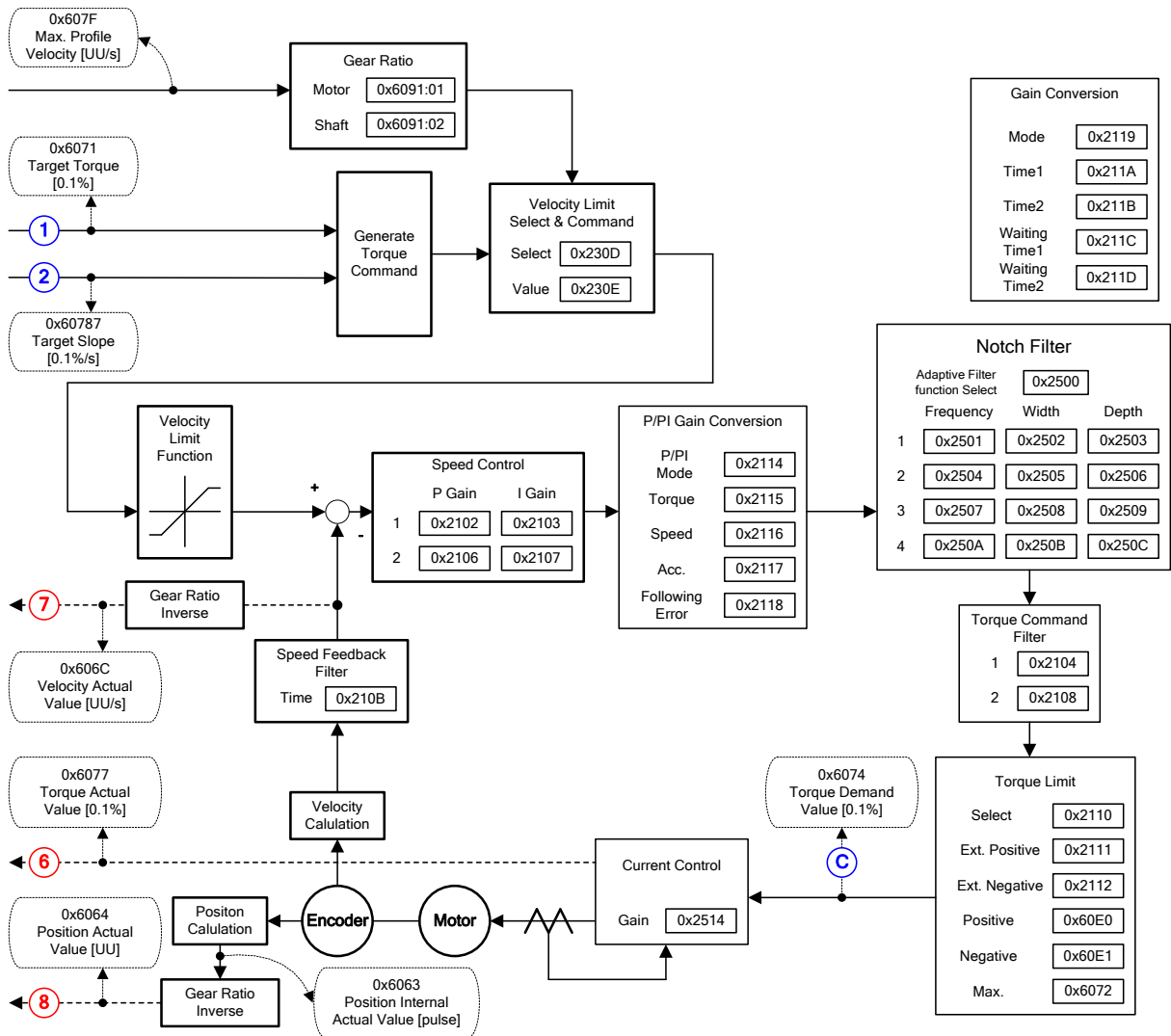

## 4.6 Homing

This drive provides its own homing function. The figure below represents the relationship between the input and output parameters for homing mode. You can specify the speed, acceleration, offset, and homing method.

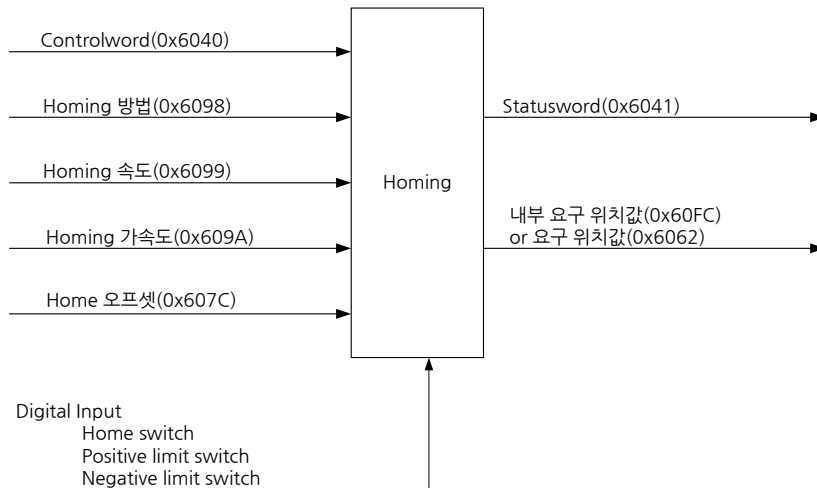

As shown in the figure below, you can set the offset between the home position and the zero position of the machine using the home offset. The zero position indicates a point whose Actual Position Value (0x6064) is zero (0).

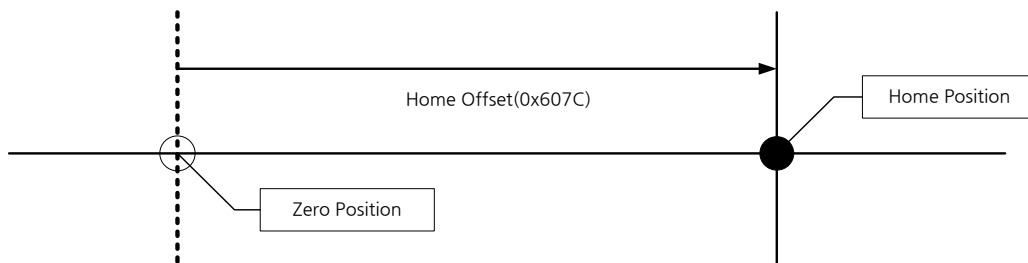

### 4.6.1 Homing Methods

The drive supports the following homing methods (0x6098):

Homing Methods (0x6098)	Description
1	The drive returns to the home position with the negative limit switch (NOT) and the Index (Z) pulse while driving in the reverse direction.
2	The drive returns to the home position with the positive limit switch (POT) and the Index (Z) pulse while driving in the forward direction.
7,8,9,10	The drive returns to the home position with the home switch (HOME) and the Index (Z) pulse while driving in the forward direction. When the positive limit switch (POT) is input during homing, the drive will switch its driving direction.



11,12,13,14	The drive returns to the home position with the home switch (HOME) and the Index (Z) pulse while driving in the reverse direction. When the negative limit switch (NOT) is input during homing, the drive will switch its driving direction.
24	The drive returns to the home position with the home switch (HOME) while driving in the forward direction. When the positive limit switch (POT) is input during homing, the drive will switch its driving direction.
28	The drive returns to the home position with the home switch (HOME) while driving in the reverse direction. When the negative limit switch (NOT) is input during homing, the drive will switch its driving direction.
33	The drive returns to the home position with the Index (Z) pulse while driving in the reverse direction.
34	The drive returns to the home position with the Index (Z) pulse while driving in the forward direction.
35	Sets the current position as the origin.
-1	The drive returns to the home position with the negative stopper and the Index (Z) pulse while driving in the reverse direction.
-2	The drive returns to the home position with the positive stopper and the Index (Z) pulse while driving in the forward direction.
-3	The drive only returns to the home position with the negative stopper while driving in the reverse direction.
-4	The drive only returns to the home position with the positive stopper while driving in the forward direction.
-5	The drive returns to the home position only with the home switch (HOME) while driving in the reverse direction.
-6	The drive returns to the home position only with the home switch (HOME) while driving in the forward direction.

■ Related Objects

Index	Sub Index	Name	Variable type	Accessibility	PDO Assignment	Unit
0x6040	-	Controlword	UNIT	RW	Yes	-
0x6041	-	Statusword	UINT	RO	Yes	-
0x607C	-	Home Offset	DINT	RW	No	UU
0x6098	-	Homing Method	SINT	RW	Yes	-
0x6099	-	Homing Speed	-	-	-	-
	0	Number of entries	USINT	RO	No	-
	1	Speed during search for switch	UDINT	RW	Yes	UU/s
	2	Speed during search for zero	UDINT	RW	Yes	UU/s
0x609A	-	Homing Acceleration	UDINT	RW	Yes	UU/s <sup>2</sup>

■ Homing Methods 1 and 2

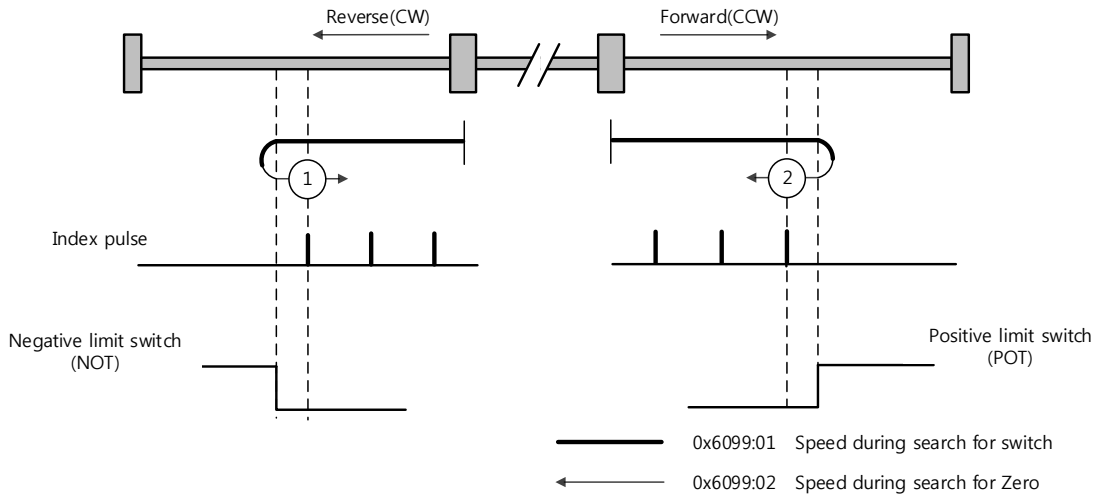

For homing using Homing Method 1, the velocity profile according to the sequence is as follows. See the details below:

**Homing Method ①**

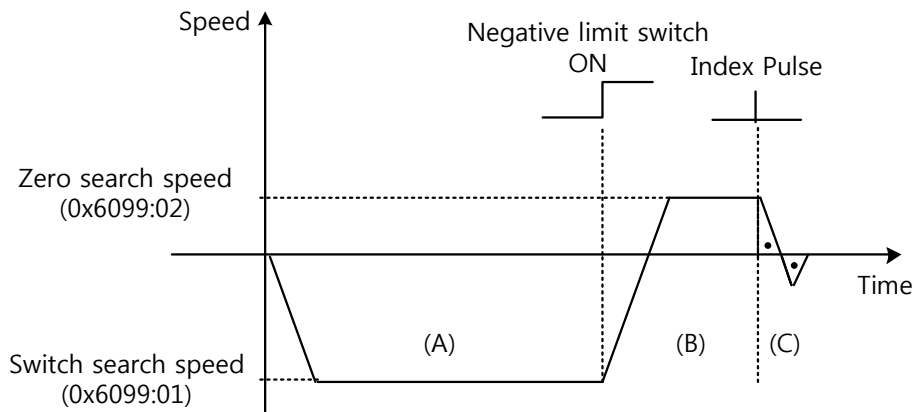

(A) The initial driving direction is reverse (CW), and the drive operates at switch search speed.

(B) When the negative limit switch (NOT) is turned on, the drive switches to the forward direction (CCW), decelerating to zero search speed.

(C) While operating at zero search speed, the drive detects the first index pulse to move to the index position (Home).

■ Methods 7, 8, 9, and 10

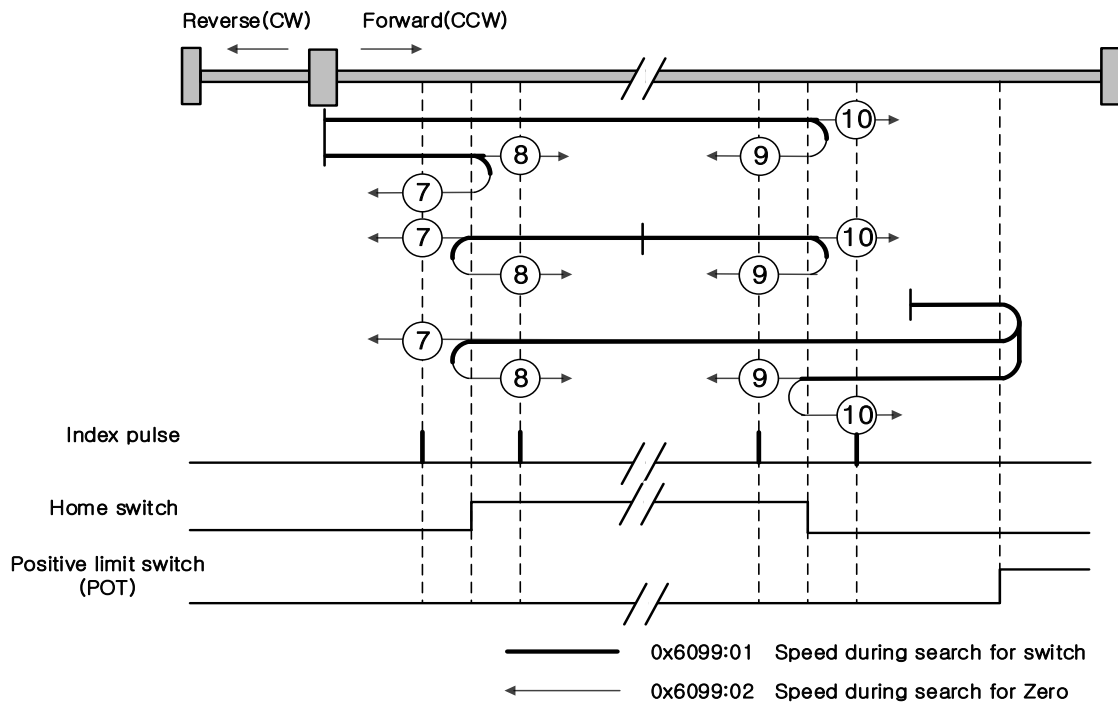

For homing using Homing Method 7, the velocity profile according to the sequence is as follows. The sequence depends on the relationship between the load position and the Home switch at homing, which is categorized into the following three cases. For more information, see the details below:

- (1) At the start of homing, when the Home switch is off and the limit is not met during operation

**Homing Method ⑦**

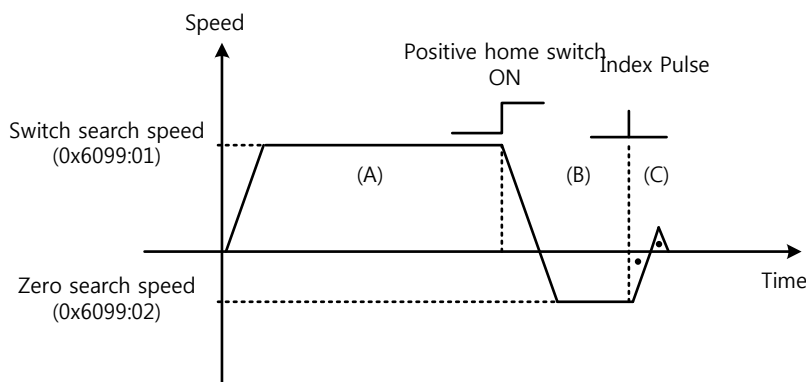

- (A) The initial driving direction is forward (CCW), and the drive operates at switch search speed.
- (B) When the Positive Home switch is turned on, the drive will decelerate to zero search speed, and then switch to the reverse direction (CW).
- (C) While operating at zero search speed, the drive detects the first index pulse to move to the index position (Home).

(2) At the start of homing, when the Home switch is on

**Homing Method ⑦**

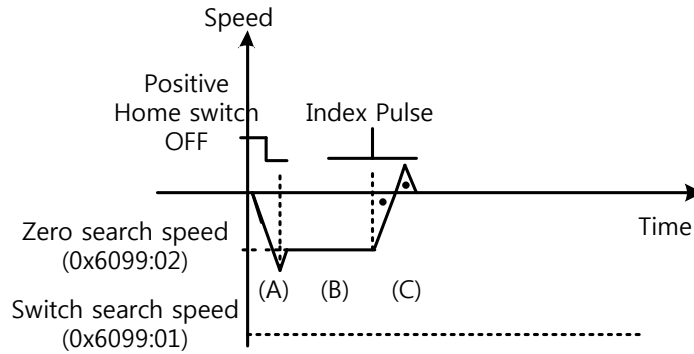

- (A) Since the Home signal is on, the drive will operate at switch search speed in the direction of the Positive Home switch (CCW). It may not reach switch search speed depending on the homing start position.
- (B) When the Home switch is turned off, the drive will decelerate to zero search speed, and then continue to operate.
- (C) While operating at zero search speed, the drive detects the first index pulse to move to the index position (Home).

(3) At the start of homing, when the Home switch is off and the limit is met during operation

**Homing Method ⑦**

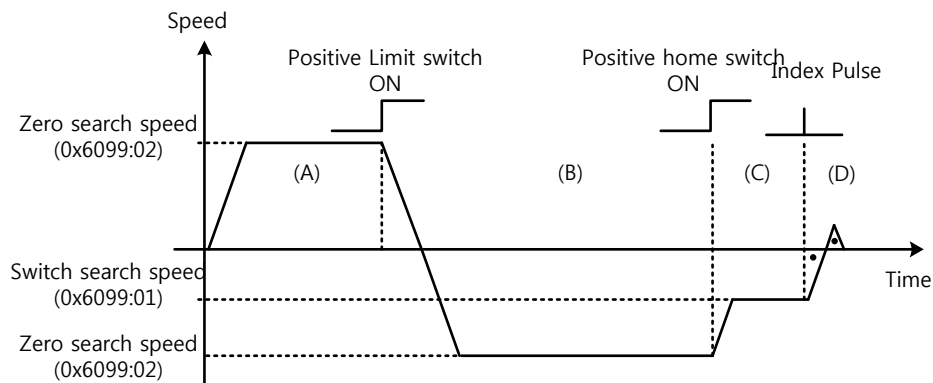

- (A) The initial driving direction is forward (CCW), and the drive operates at switch search speed.
- (B) When the positive limit switch (POT) is turned on, the drive will decelerate to a stop, and then operate at switch search speed in the reverse direction (CW).

- (C) When the Positive Home switch is turned off, the drive will decelerate to zero search speed, and then continue to operate.
- (D) While operating at zero search speed, the drive detects the first index pulse to move to the index position (Home).

Methods 8 to 10 are nearly identical to method 7 in terms of the homing sequence. The only differences are the initial driving direction and Home switch polarity.

The Positive Home switch is determined by the initial driving direction. A Home switch that is encountered in the initial driving direction becomes the Positive Home switch.

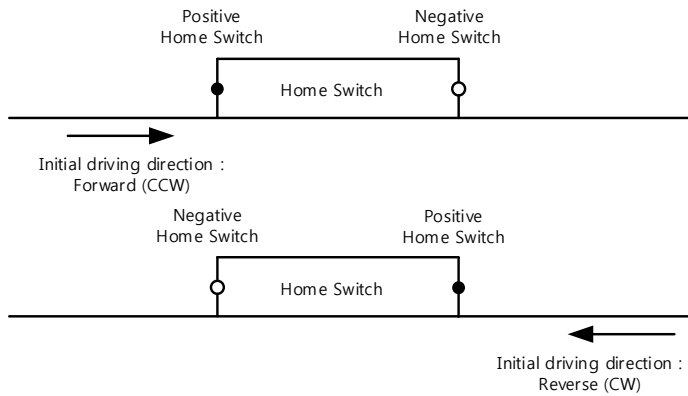

■ Methods 11, 12, 13, and 14

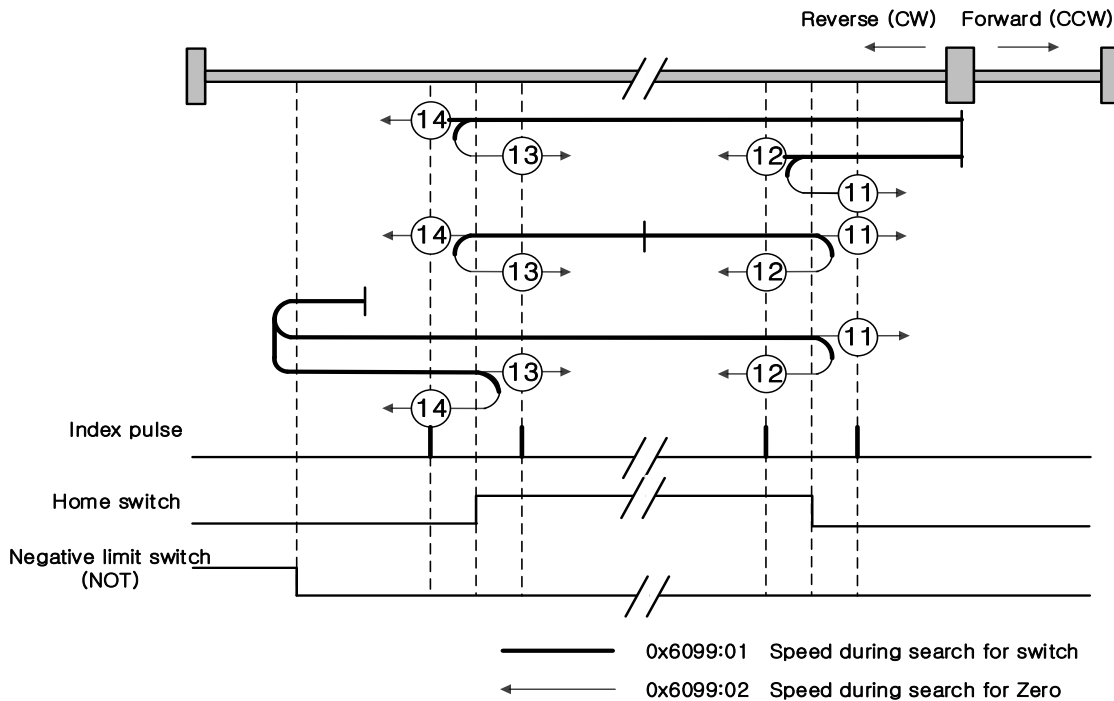

For homing using Homing Method 14, the velocity profile according to the sequence is as follows. The sequence depends on the relationship between the load position and the

Home switch at homing, which is categorized into the following three cases. For more information, see the details below:

(1) At the start of homing, when the Home switch is off and the limit is not met during operation

#### Homing Method ⑭

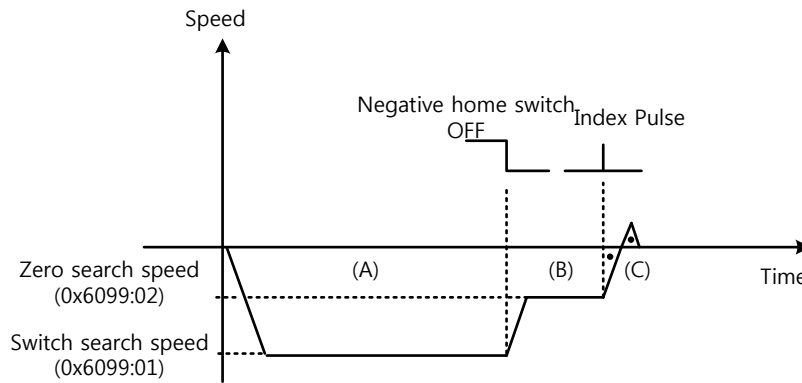

- (A) The initial driving direction is reverse (CW), and the drive operates at switch search speed.
- (B) When the Negative Home switch is turned off, the drive will decelerate to zero search speed, and then continue to operate.
- (C) While operating at zero search speed, the drive detects the first index pulse to move to the index position (Home).

(2) At the start of homing, when the Home switch is on

#### Homing Method ⑭

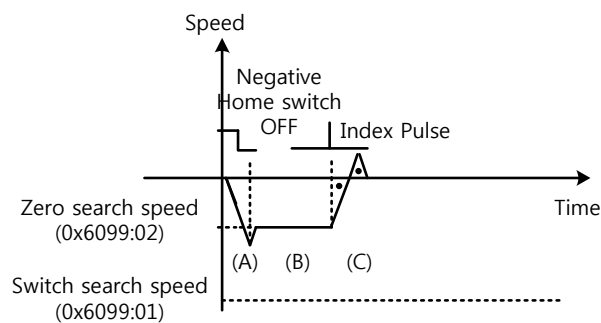

- (A) Since the Home signal is on, the drive will operate at switch search speed in the direction of the Negative Home switch (CW). It may not reach switch search speed depending on the homing start position.
- (B) When the Home switch is turned off, the drive will decelerate to zero search speed, and then continue to operate.
- (C) While operating at zero search speed, the drive detects the first index pulse to move to the index position (Home).

(3) At the start of homing, when the Home switch is off and the limit is met during operation

**Homing Method 14**

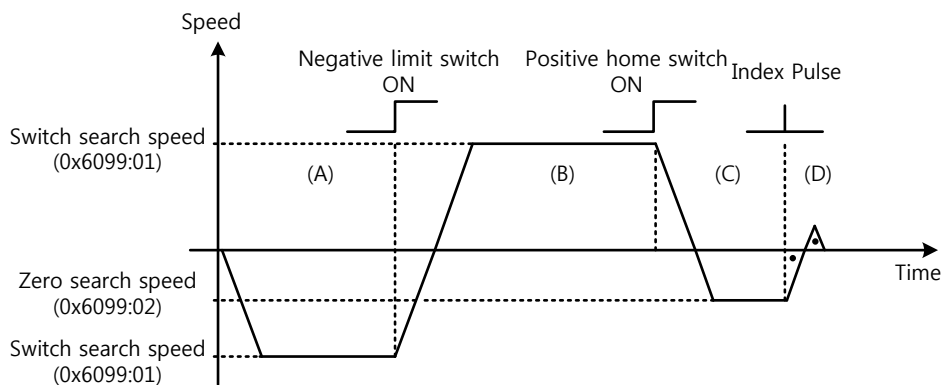

- (A) The initial driving direction is reverse (CW), and the drive operates at switch search speed.
- (B) When the negative limit switch (NOT) is turned on, the drive will decelerate to a stop, and then operate at switch search speed in the forward direction (CCW).
- (C) When the Negative Home switch is turned on, the drive will decelerate to zero search speed, and then switch to the reverse direction (CW).
- (D) While operating at zero search speed, the drive detects the first index pulse to move to the index position (Home).

Methods 11 to 13 are nearly identical to method 14 in terms of the homing sequence. The only differences are the initial driving direction and Home switch polarity.

■ Method 24

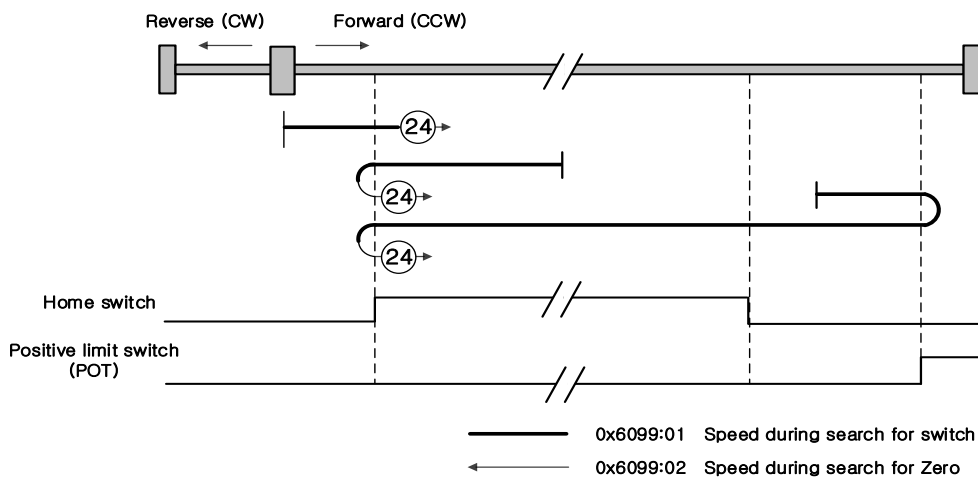

The initial driving direction is forward (CCW), and the point where the Positive Home switch is turned on becomes the Home position.

■ Method 28

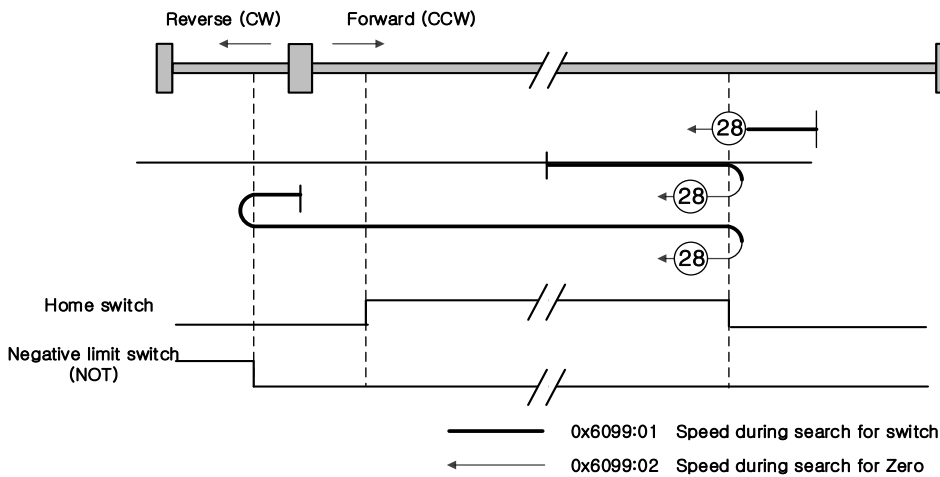

The initial driving direction is reverse (CW), and the point where the Positive Home switch is turned on becomes the Home position.

■ Methods 33 and 34

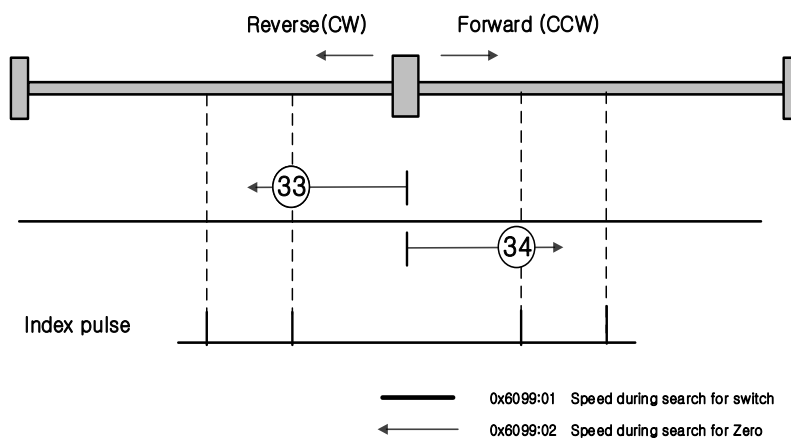

The initial driving direction is reverse (CW) for method 33, and forward (CCW) for method 34. The drive detects the index pulse at zero search speed.



■ Method 35

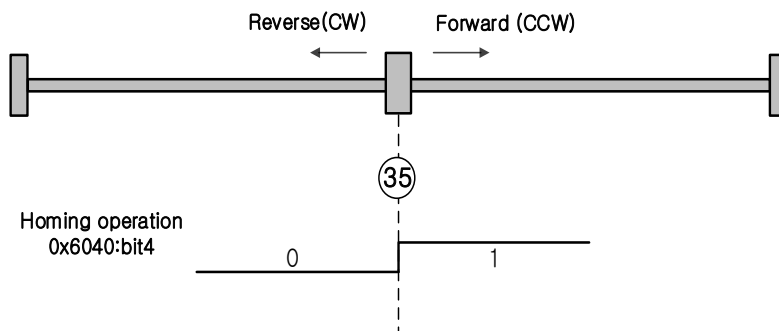

The current position at the startup of the homing operation becomes the Home position. This method is used to change the current position to the origin depending on the demand for the upper level controller.

Besides the standard methods, homing methods -1, -2, -3, -4, -5, and -6 are supported by this drive. They can be used if the Home switch is not used separately.

■ Methods -1 and -2

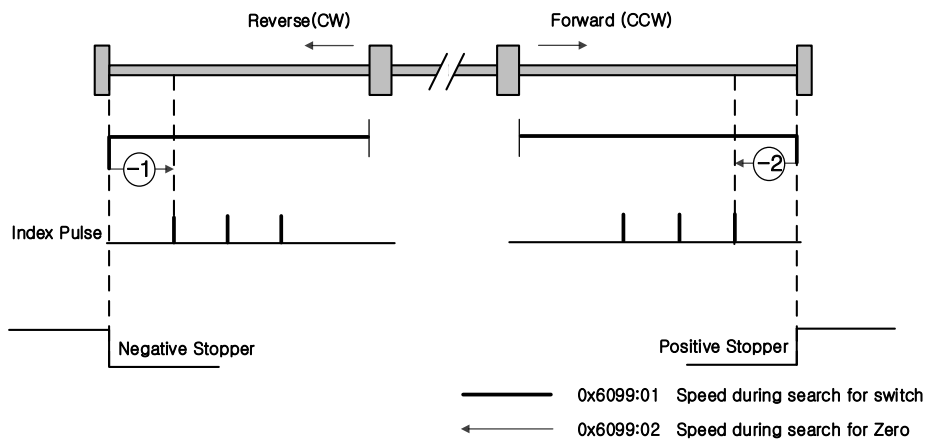

Homing method -1 and -2 use the stopper and index (Z) pulse to perform homing. The velocity profile according to the sequence is as follows. For more information, see the details below:

**Homing Method ①**

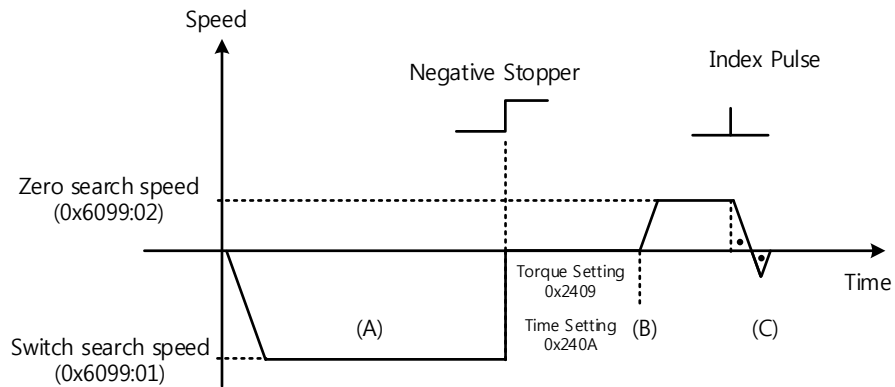

- (A) The initial driving direction is reverse (CW), and the drive operates at switch search speed.
- (B) When the drive hits the negative stopper, it will stand by according to the torque limit value (0x2409) and the time setting value (0x240A) at the time of homing using the stopper before direction switching.
- (C) While operating at zero search speed, the drive detects the first index pulse to move to the index position (Home).

**Homing Method ②**

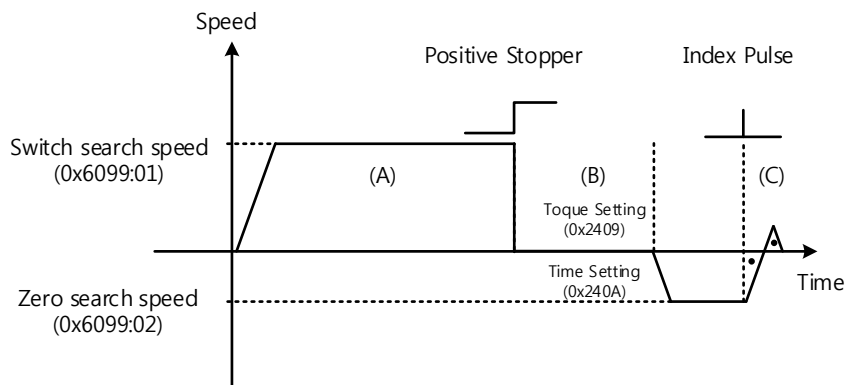

- (A) The initial driving direction is forward (CCW), and the drive operates at switch search speed.
- (B) When the drive hits the positive stopper, it will stand by according to the torque limit value (0x2409) and the time setting value (0x240A) at the time of homing using the stopper before direction switching.
- (C) While operating at zero search speed, the drive detects the first index pulse to move to the index position (Home).

■ Methods -3 and -4

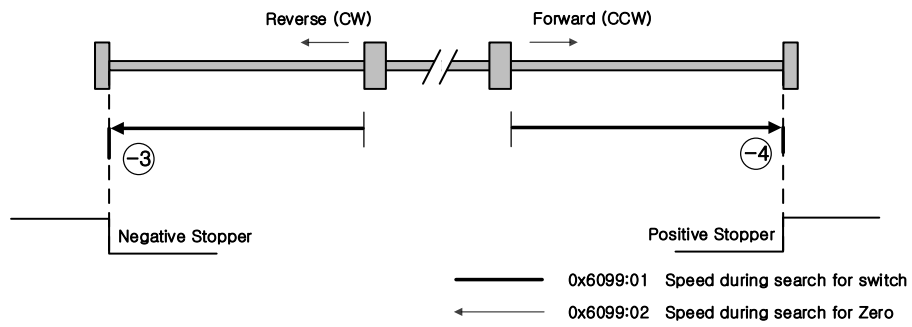

Homing methods -3 and -4 only use the stopper to perform homing. The velocity profile according to the sequence is as follows. For more information, see the details below:

**Homing Method  $\ominus$**

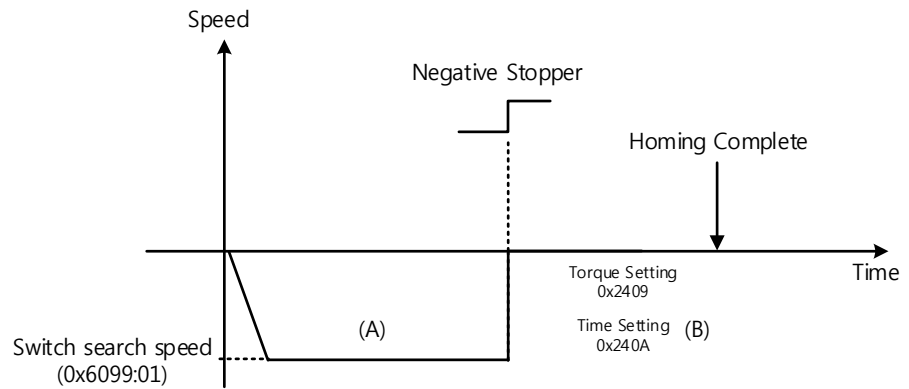

(A) The initial driving direction is reverse (CW), and the drive operates at switch search speed.

(B) When the drive hits the negative stopper, it stands by according to the torque limit value (0x2409) and the time setting value (0x240A) at the time of homing using the stopper and finishes homing.

**Homing Method  $\omin�$**

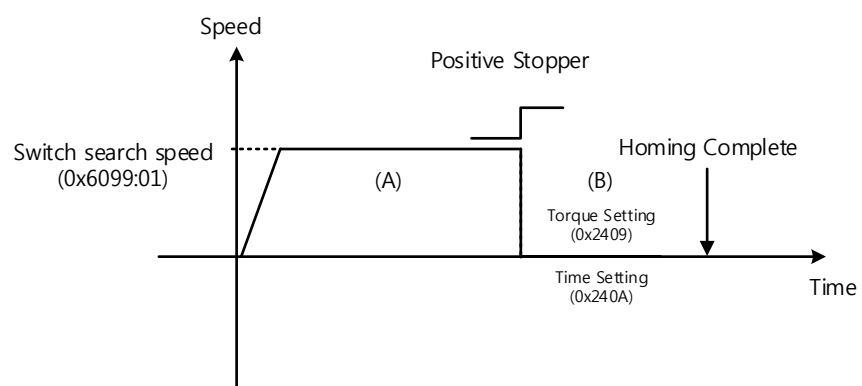

- (A) The initial driving direction is forward (CCW), and the drive operates at switch search speed.
- (B) When the drive hits the positive stopper, it stands by according to the torque limit value (0x2409) and the time setting value (0x240A) at the time of homing using the stopper and finishes homing.

■ Methods -5 and -6

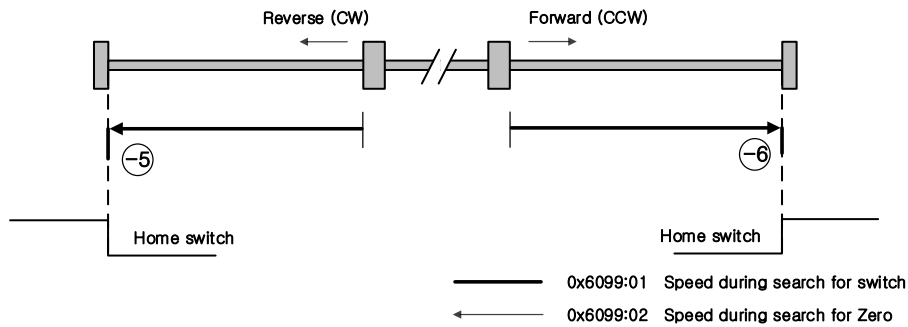

Homing methods -5 and -6 only use the Home switch to perform homing. The velocity profile according to the sequence is as follows. Homing stops when the drive meets the limit switch during homing. For more information, see the details below:

- (1) At the start of homing, when the Home switch is off and the limit is not met during operation

Homing Method ⑤

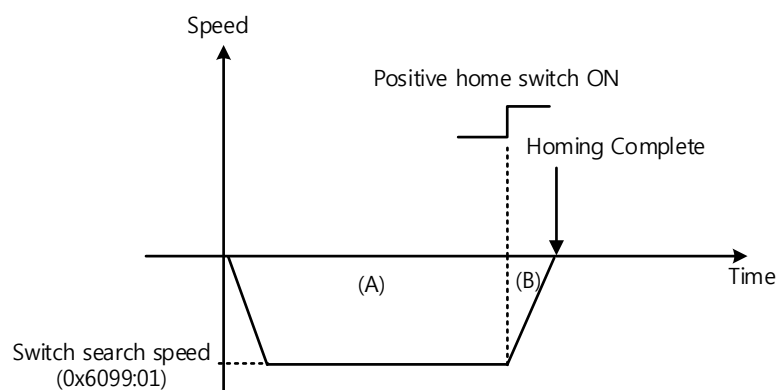

- (A) The initial driving direction is reverse (CW), and the drive operates at switch search speed.
- (B) When the positive home switch is on, the driver decelerates to a stop and finishes homing.

- (2) At the start of homing, when the Home switch is off and the limit is met during operation

**Homing Method  $\ominus$**

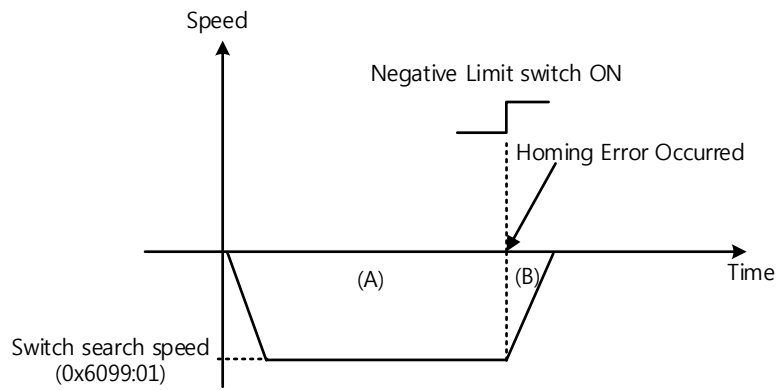

- (A) The initial driving direction is reverse (CW), and the drive operates at switch search speed.  
 (B) If the negative limit switch is on, a homing error occurs and the drive decelerates to a stop.

**Homing Method  $\oplus$**

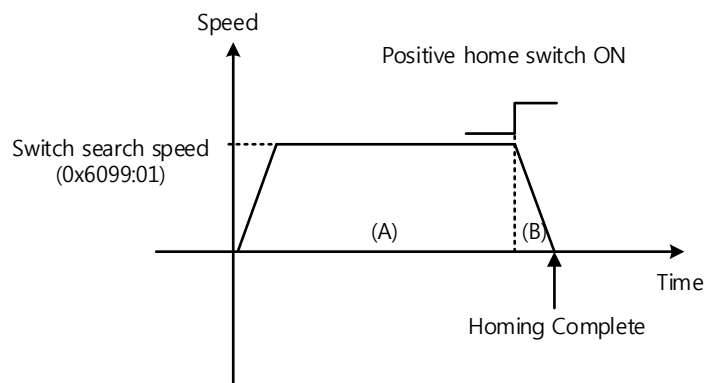

- (A) The initial driving direction is forward (CCW), and the drive operates at switch search speed.  
 (B) When the positive home switch is on, the driver decelerates to a stop and finishes homing.

## 4.7 Touch Probe Function

The touch probe is a function that rapidly captures the position value of the encoder with external input (PROBE 1 and 2) signals or the index (Z) pulse of the encoder.

- Example of Touch Probe

Wafer mapper system of wafer transfer robot (WTR)

When wafers are piled up on a wafer stack, the presence of wafers can be determined by scanning the stack once using a mapping sensor. At this time, any unnecessary movement by the robot can be prevented using the value of the wafer loading position, which has been captured rapidly.

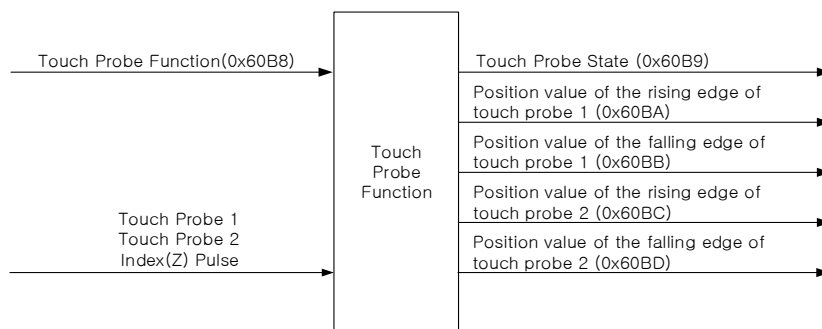
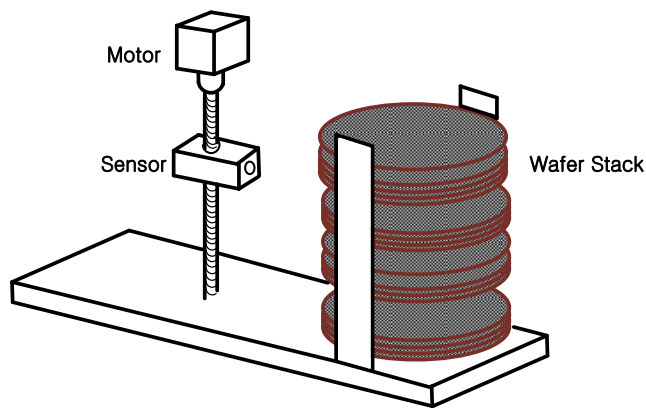

The position value of the encoder (Actual Position Value, 0x6064) is latched by the following trigger events according to the setting value. At the same time, 2 channel inputs can be latched independently at the positive/negative edges.

- Triggered by touch probe 1 (CN1, PROBE1)
- Triggered by touch probe 2 (CN1, PROBE2)
- Triggered by the encoder index (Z) pulse

■ Related Objects

Index	Sub Index	Name	Variable type	Accessibility	PDO Assignment	Unit
0x60B8	-	Touch Probe Function	UINT	RW	Yes	-
0x60B9	-	Touch Probe Status	UINT	RO	Yes	-
0x60BA	-	Touch Probe 1 Positive Edge Position Value	DINT	RO	Yes	UU
0x60BB	-	Touch Probe 1 Negative Edge Position Value	DINT	RO	Yes	UU
0x60BC	-	Touch Probe 2 Positive Edge Position Value	DINT	RO	Yes	UU
0x60BD	-	Touch Probe 2 Negative Edge Position Value	DINT	RO	Yes	UU

■ Touch Probe Timing Diagram

Single Trigger Mode (0x60B8.1=0, 0x60B8.9=0):

To reset bits 1, 2, 9, and 10 of the touch probe status (0x60B9) in single trigger mode, set the corresponding bits (4, 5, 12, and 13) of the touch probe function (0x60B8) to 0.

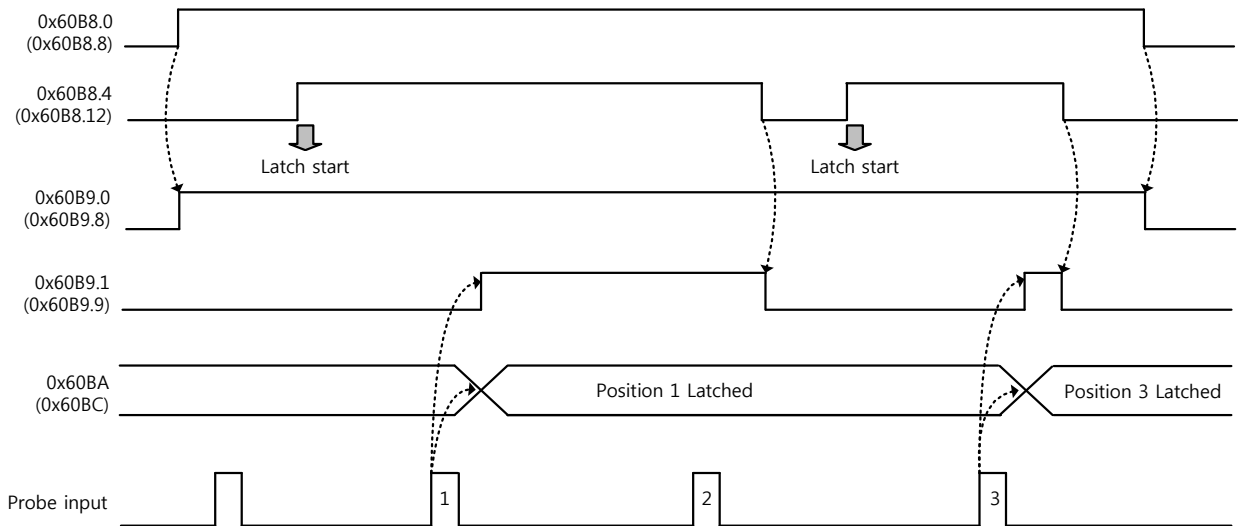

Continuous Trigger Mode (0x60B8.1=1, 0x60B8.9=1):

In continuous trigger mode, bits 6, 7, 14, and 15 of the touch probe status (0x60B9) toggle (0 → 1 or 1 → 0) every time the corresponding input/edge is input.

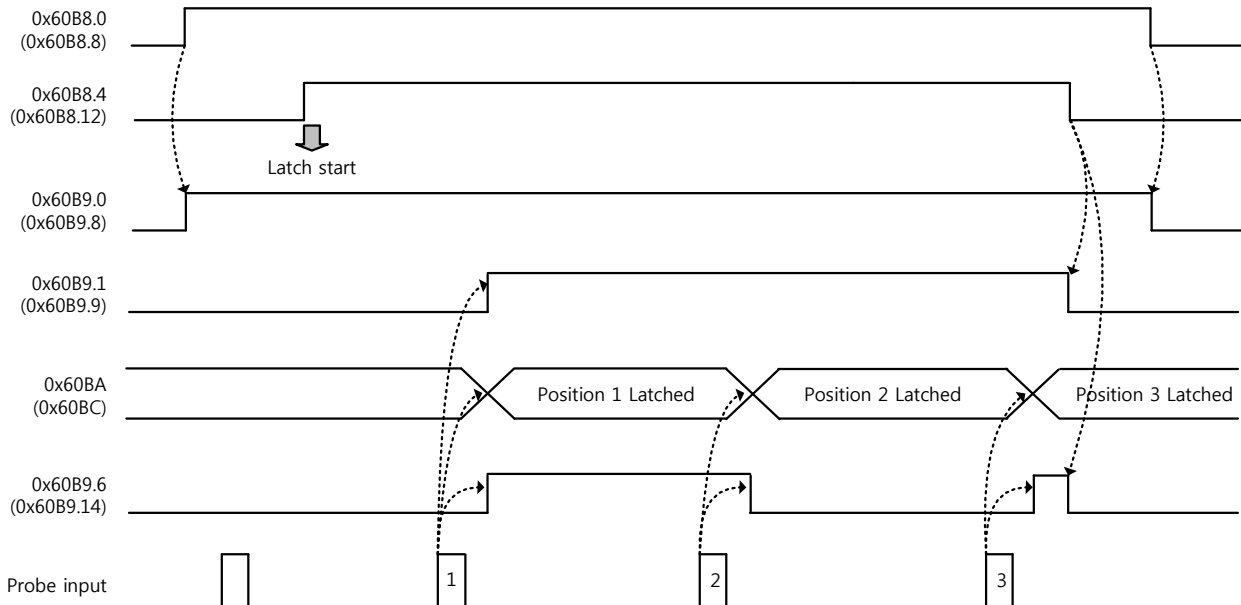

Index Pulse Trigger Mode (0x60B8.2=1, 0x60B8.10=1):



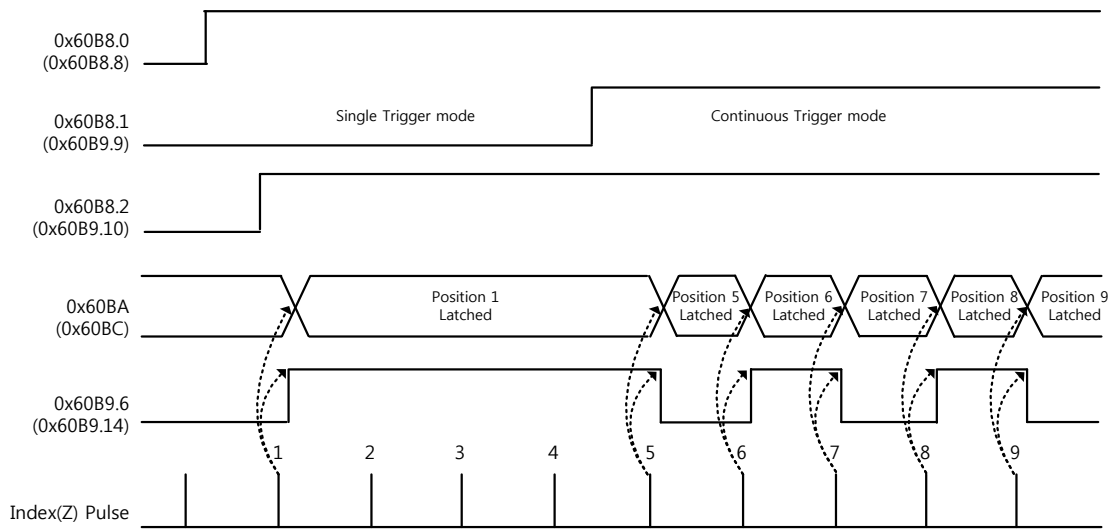

# 5. Drive Application Functions

## 5.1 Settings for Input/Output Signals

### 5.1.1 Assignments for Digital Input Signals

You can set the digital input signal function and input signal level of the I/O connector. As shown in the figure below, you can arbitrarily assign up to 4 input functions, out of 33 functions, to digital input signals 1 - 4 for use:

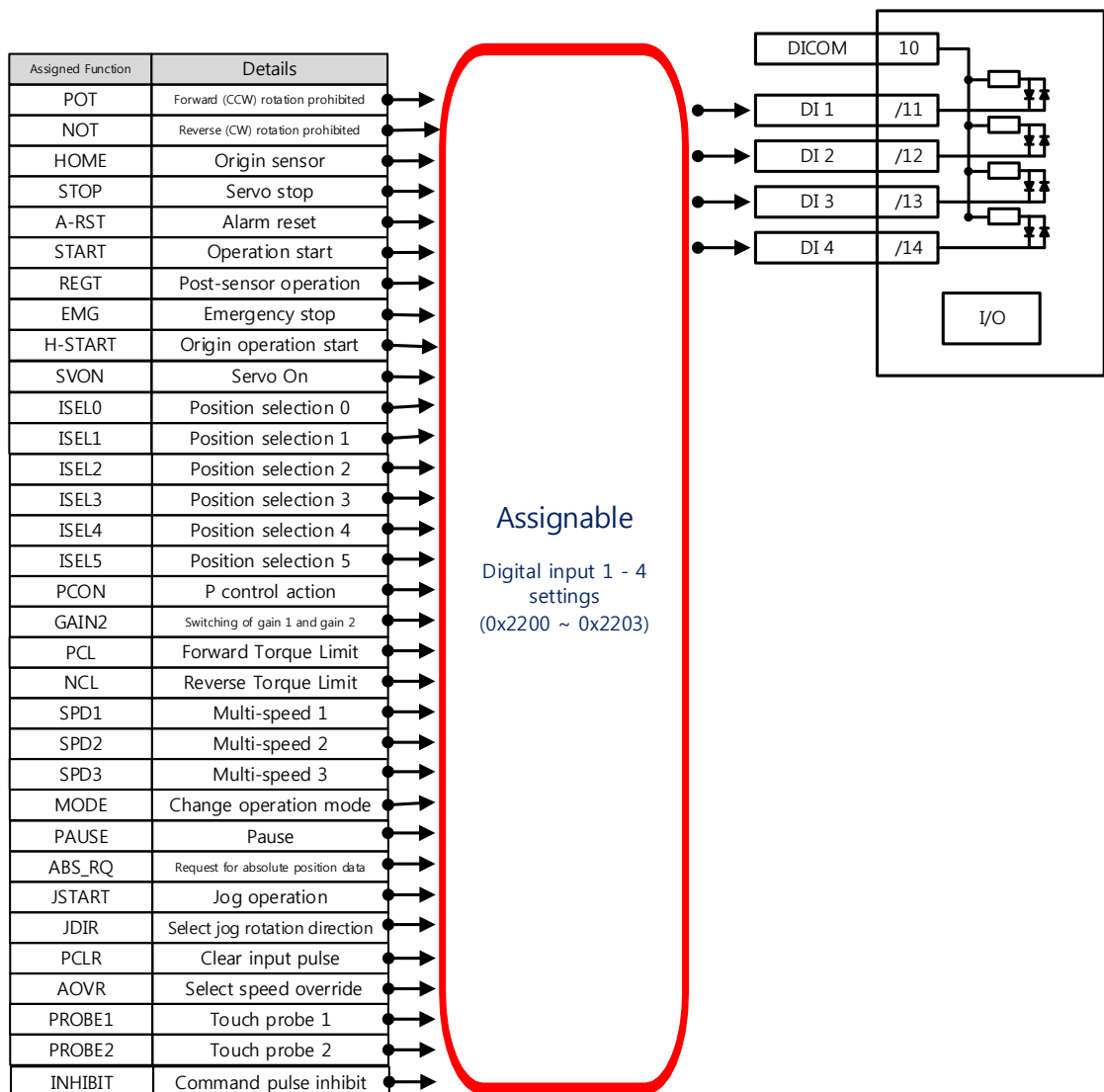

■ Related Objects

Index	Sub Index	Name	Variable type	Accessibility	PDO Assignment	Unit
0x2200	-	Digital Input Signal 1 Selection	UINT	RW		-
0x2201	-	Digital Input Signal 2 Selection	UINT	RW		-
0x2202	-	Digital Input Signal 3 Selection	UINT	RW		-
0x2203	-	Digital Input Signal 4 Selection	UINT	RW		-

Set the functions of the digital input signals of CN1 and the input signal level. Select signals to assign with bits 7 - 0, and set the signal level to bit 15.

Bit	Setting details
15	Signal input level settings (0: contact A, 1: contact B)
14~8	Reserved
7~0	Input signal assignments

Contact A: The default status is 0 (Low). Input 1 (High) to actuate it (Active High).

Contact B: The default status is 1 (High). Input 0 (Low) to actuate it (Active Low).

Settings	Assigned signal	Settings	Assigned signal	Settings	Assigned signal
0x00	Not assigned	0x10	START	0x20	SPD1
0x01	POT	0x11	PAUSE	0x21	SPD2
0x02	NOT	0x12	REGT	0x22	SPD3
0x03	HOME	0x13	HSTART	0x23	MODE
0x04	STOP	0x14	ISEL0		
0x05	PCON	0x15	ISEL1		
0x06	GAIN2	0x16	ISEL2		
0x07	P_CL	0x17	ISEL3		
0x08	N_CL	0x18	ISEL4		
0x09	PROBE1	0x19	ISEL5		
0x0A	PROBE2	0x1A	ABSRQ		
0x0B	EMG	0x1B	JSTART		
0x0C	A_RST	0x1C	JDIR		
		0x1D	PCLR		
		0x1E	AOVR		
0x0F	SV_ON	0x1F	INHIB		

■ Example of Assigning Digital Input Signals

The following table shows an example of assigning input signals. Verify the setting from 0x2200 to 0x2203.

DI#1	DI#2	DI#3	DI#4
POT (Contact B)	NOT (Contact B)	HOME (Contact A)	STOP (Contact A)

Assigned Function	Contact	Details
0x01	POT	B Forward (CCW) rotation prohibited
0x02	NOT	B Reverse (CW) rotation prohibited
0x03	HOME	A Origin sensor
0x04	STOP	A Servo stop
0x05	PCON	A P control action
0x06	GAIN2	A Switching of gain 1 and gain 2
0x07	PCL	- Forward Torque Limit
0x08	NCL	- Reverse Torque Limit
0x09	PROBE1	A Touch probe 1
0x0A	PROBE2	- Touch probe 2
0x0B	EMG	A Emergency stop
0x0C	ARST	A Alarm reset

CN1 (Pin Number)	Parameter	Bit		Settings	Details
		15	7~0		
DI # 1 (2)	0x2200	1	0x01	0x8001	POT(Contact B)
DI # 2 (3)	0x2201	1	0x02	0x8002	NOT(Contact B)
DI # 3 (4)	0x2202	0	0x03	0x0003	HOME(Contact A)
DI # 4 (5)	0x2203	0	0x04	0x0004	STOP(Contact A)

### 5.1.2 Assignment of Digital Output Signals

You can set the digital output signal function and the output signal level of the I/O connector. As shown in the figure below, you can arbitrarily assign up to 4 output functions, out of 19 functions, to the digital output signals 1 - 4 for use:

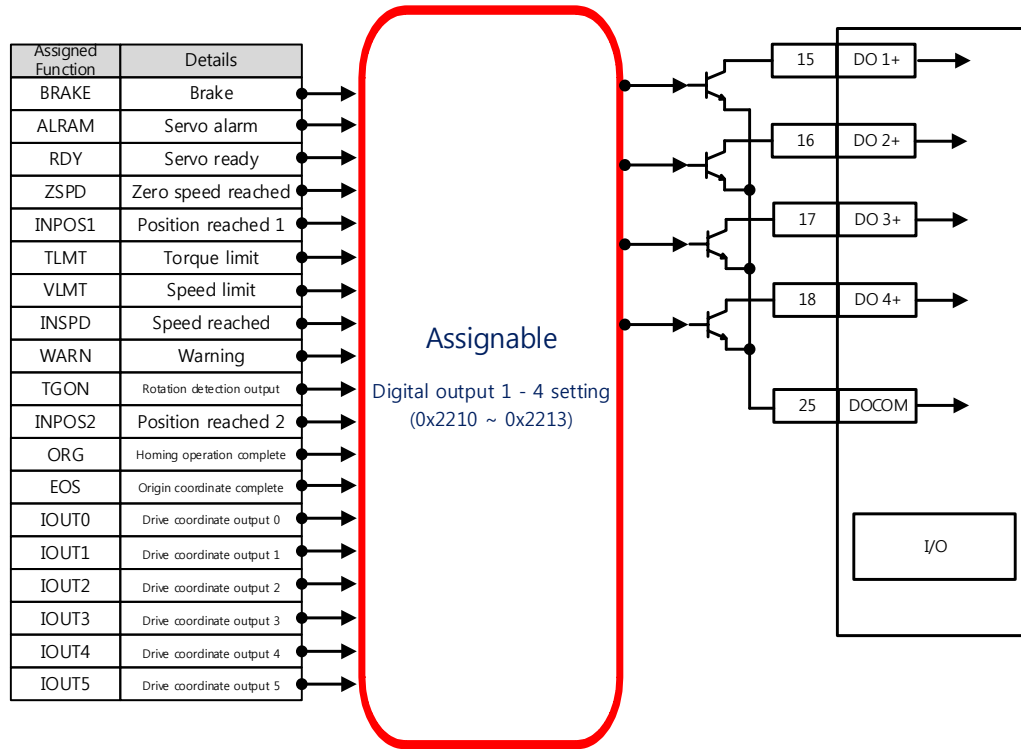

■ Related Objects

Index	Sub Index	Name	Variable type	Accessibility	PDO Assignment	Unit
0x2210	-	Digital Output Signal 1 Selection	UINT	RW		-
0x2211	-	Digital Output Signal 2 Selection	UINT	RW		-
0x2212	-	Digital Output Signal 3 Selection	UINT	RW		-
0x2213	-	Digital Output Signal 4 Selection	UINT	RW		-

Assign the functions of the digital output signal 1 of CN1 and set the output signal level. Select signals to assign with bits 7 - 0, and set the signal level to bit 15.

Bit	Setting details
15	Signal output level settings (0: contact A, 1: contact B)
14~8	Reserved
7~0	Output signal assignments

Settings	Assignable output signal	Settings	Assignable output signal
0x00	Not assigned	0x10	ORG
0x01	BRAKE	0x11	EOS
0x02	ALARM	0x12	IOOUT0
0x03	RDY	0x13	IOOUT1
0x04	ZSPD	0x14	IOOUT2
0x05	INPOS1	0x15	IOOUT3
0x06	TLMT	0x16	IOOUT4
0x07	VLMT	0x17	IOOUT5
0x08	INSPD		
0x09	WARN		
0x0A	TGON		
0x0B	INPOS2		

### ■ Examples of Assigning Digital Output Signals

The following table shows examples of assigning output signals. Verify the settings from 0x2210 to 0x2213.

DO#1	DO#2	DO#3	DO#4
BRAKE (Contact B)	ALARM (Contact B)	RDY (Contact A)	ZSPD (Contact A)

Assigned Function	Contact	Details
0x01	BRAKE	B
0x02	ALARM	B
0x03	READY	A
0x04	ZSPD	A
0x05	INPOS1	-
0x06	TLMT	-
0x07	VLMT	-
0x08	INSPD	-
0x09	WARN	-
0x0A	TGON	-
0x0B	INPOS2	-

CN1 (Pin Number)	Parameter	Bit		Settings	Details
		15	7~0		
DO # 1 (15)	0x2210	1	0x01	0x8001	BRAKE(Contact B)
DO # 2 (16)	0x2211	1	0x02	0x8002	ALARM(Contact B)
DO # 3 (17)	0x2212	0	0x03	0x0003	RDY(Contact A)
DO # 4 (18)	0x2213	0	0x04	0x0004	ZSPD(Contact A)

### 5.1.3 Use of User I/O

User I/O means some of the I/Os provided by the drive are used for controlling the drive itself and for the user's individual purposes. All contacts provided by the input/output connector (I/O) can be used as the User I/O.

If only a few user I/Os are needed, you can wire the drive with the I/O connector rather than a separate I/O module, reducing the cost.

The Phoenix drive is available with up to 4 points for input signals and 4 points for output signals as the user I/O.

■ How to Set the User Input

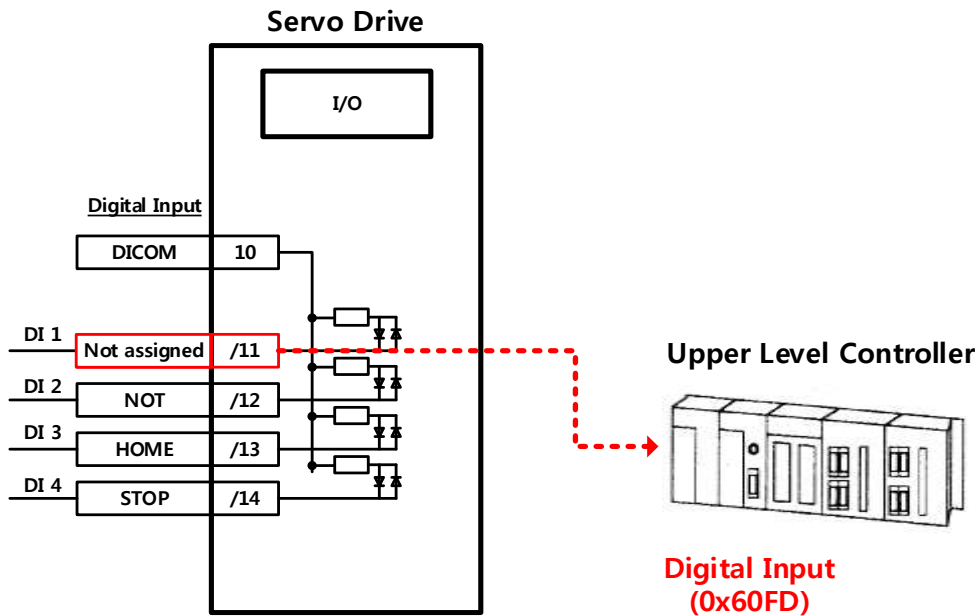

- 1) Set the function of the digital input port to be used as the user input to "Not assigned (setting 0)." (Refer to Input Signal Assignments.)
- 2) Read the values of the corresponding bits (0x60FD.16 - 23) from the digital input (0x60FD) to use them as the user input.

■ Related Objects

Index	Sub Index	Name	Variable type	Accessibility	PDO Assignment	Unit
0x60FD	-	Digital Inputs	UDINT	RO	Yes	-

Bit	Description
0	NOT (negative limit switch)
1	POT (positive limit switch)



2	HOME (origin sensor input)
3 to 15	Reserved
16	DI #1(CN1 pin 2), 0:Open, 1:Close
17	DI #2(CN1 pin 3), 0:Open, 1:Close
18	DI #3(CN1 pin 4), 0:Open, 1:Close
19	DI #4(CN1 pin 5), 0:Open, 1:Close
20 to 30	Reserved
31	STO(Safe Torque Off), 0:Close, 1:Open

■ How to Set the User Output

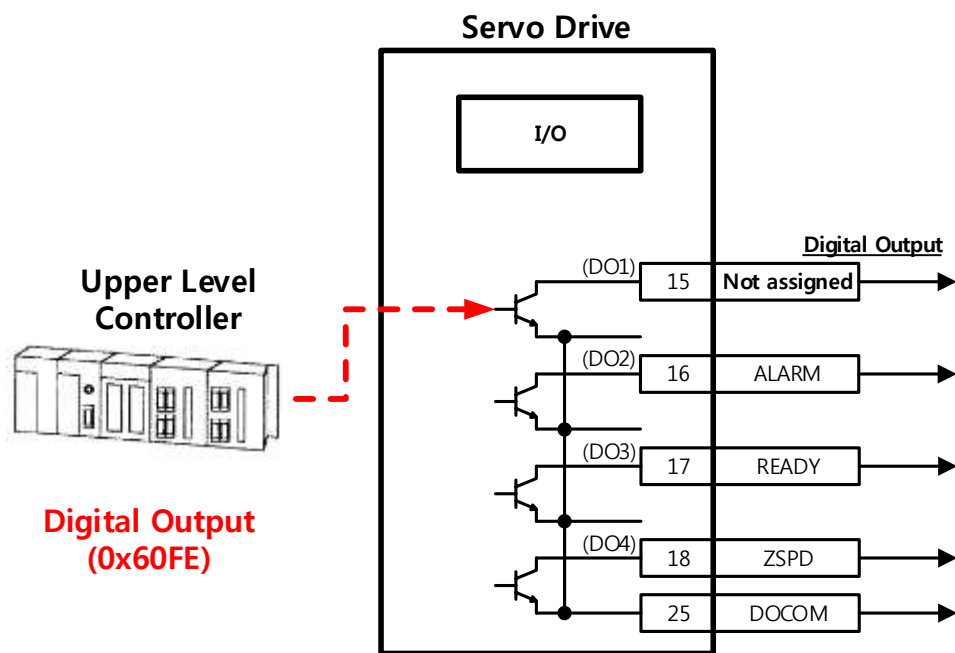

- 1) Set the function of the digital output port to be used as the user output to "Not assigned (setting 0)." (Refer to Output Signal Assignments.)
- 2) Set the bits (bits 16 - 19) corresponding to the port used as the user output for the bit mask (0x60FE:02) to Forced Output Enabled (setting 1).
- 3) Using physical outputs (0x60FE:01), set the value corresponding to the user output for the relevant port (bits 16 - 19) to 0 or 1.

■ Related Objects

Index	Sub Index	Name	Variable type	Accessibility	PDO Assignment	Unit
0x60FE	-	Digital Outputs	-	-	-	-
	0	Number of entries	USINT	RO	No	
	1	Physical outputs	UDINT	RW	Yes	-
	2	Bit mask	UDINT	RW	No	-

They indicate the status of digital outputs.

- Description of physical outputs

Bit	Description
0 to 15	Reserved
16	Forced output (0: OFF, 1: ON) of DO #1 (CN1 pin 15) Provided that the relevant bit mask (0x60FE:02.16) is set to 1.
17	Forced output (0: OFF, 1: ON) of DO #2 (CN1 pin 16) Provided that the relevant bit mask (0x60FE:02.17) is set to 1.
18	Forced output (0: OFF, 1: ON) of DO #3 (CN1 pin 17) Provided that the relevant bit mask (0x60FE:02.18) is set to 1.
19	Forced output (0: OFF, 1: ON) of DO #4 (CN1 pin 18) Provided that the relevant bit mask (0x60FE:02.19) is set to 1.
20 to 23	Reserved
24	Output status of DO #1 (0: OFF, 1: ON)
25	Output status of DO #2 (0: OFF, 1: ON)
26	Output status of DO #3 (0: OFF, 1: ON)
27	Output status of DO #4 (0: OFF, 1: ON)
28 to 31	Reserved

- Description of bit mask

Bit	Description
0 to 15	Reserved
16	Forced output setting (0: Disable, 1: Enable) of DO #1 (CN1 pin 15)
17	Forced output setting (0: Disable, 1: Enable) of DO #2 (CN1 pin 16)
18	Forced output setting (0: Disable, 1: Enable) of DO #3 (CN1 pin 17)
19	Forced output setting (0: Disable, 1: Enable) of DO #4 (CN1 pin 18)
20 to 31	Reserved

## 5.2 Electric Gear Setup

### 5.2.1 Electric Gear

This function sets the electric gear when you want to drive a motor with a user unit, the minimum unit in which the user intends to give a command.

When using the electric gear function of the drive, you cannot utilize the highest resolution of the encoder; thus, if the upper level controller has the function, please use it.

Set the gear ratio within the range of 1000 to 1/1000.



Typically, electric gears are used in the following situations:

- (1) When trying to drive the load based on the user unit
  - You can command the driving based on the user unit, regardless of the encoder (motor) type. For the ball screw type of encoder with a 10 mm pitch, a comparison is given below for 12 mm of movement:

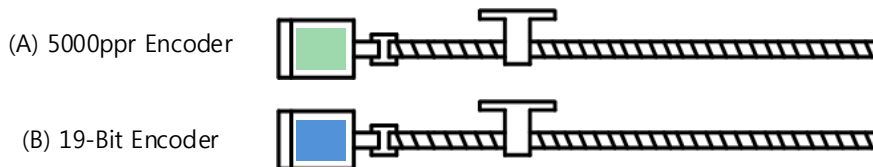

	(A) 5000 ppr encoder	(B) 19-bit (524288 ppr) encoder
If the electric gear is not used	$5000 \times 12 / 10 = 6000$	$524288 \times 12 / 10 = 629145.6$
	Different commands should be given depending on the encoder (motor) used for movement in the same distance.	
<b>For a command given in the minimum user unit of 1 <math>\mu</math>m (0.001 mm)</b>		

Electric gear settings	Motor Revolutions =5000 Shaft Revolutions = 10000	Motor Revolutions =524288 Shaft Revolutions = 10000
If the electric gear is used	Can move through the same command of 12000 (12 mm = 12000 * 1 um), regardless of the encoder (motor) used.	

(2) When driving a high-resolution encoder at high speeds but the output frequency of the upper level controller or the input frequency of the drive is limited

- The output frequency of a general high-speed line drive pulse output unit is approximately 500 Kpps, while the allowed input frequency of the drive is approximately 1 - 4 Mpps. For this reason, when driving a high-resolution encoder at high speeds, be sure to use an electric gear for proper driving due to the limitations of the output frequency of the upper level controller and the input frequency of the drive. However, you do not have to use an electric gear *because there are no such limitations for communication-type drives (EtherCAT) like this drive.*

### 5.2.2 Example of Electric Gear Setup

#### ■ Ball Screw Load

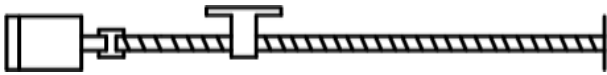
Apparatus specifications	 Pitch: 10 mm, Reduction gear ratio: 1/1
User Unit	1um(0.001mm)
Encoder specifications	19-bit (524288 PPR)
Amount of load movement/revolution	10[mm] = 10000[User Unit]
Electric gear settings	Motor Revolutions : 524288 Shaft Revolutions : 10000

#### ■ Turntable Load

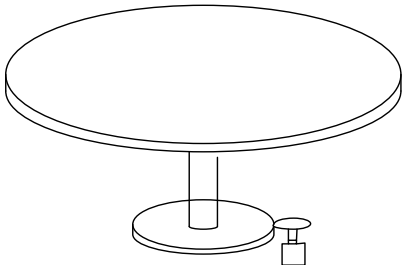
Apparatus specifications	 Reduction gear ratio: 100/1
User Unit	0.001°
Encoder specifications	19-bit (524288 PPR)
Amount of load	360/100/0.001=3600

movement/revolution	
Electric gear settings	Motor Revolutions : 524288 Shaft Revolutions : 3600

■ Belt + Pulley System

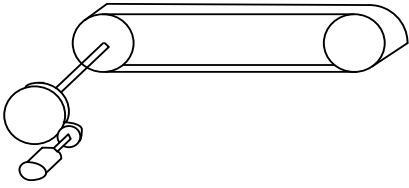
Apparatus specifications	 <p>Reduction gear ratio: 10/1, Pulley diameter: 100 mm</p>
User Unit	1um(0.001mm)
Encoder specifications	19-bit (524288 PPR)
Amount of load movement/revolution	$\pi * 100 / 10 / 0.001 = 31416$
Electric gear settings	Motor Revolutions : 524288 Shaft Revolutions : 31416

## 5.3 Settings Related to Speed Control

### 5.3.1 Smooth Acceleration and Deceleration

For smoother acceleration and deceleration during speed control, you can generate an acceleration/deceleration profile with trapezoidal and S-curved shapes for driving. In this case, the S-curve operation is enabled by setting the speed command S-curve time to a value of 0 ms or more.

The speed command acceleration/deceleration time (0x2301 and 0x2302) is the time needed to accelerate the drive from zero speed to the rated speed or to decelerate it from the rated speed to zero speed.

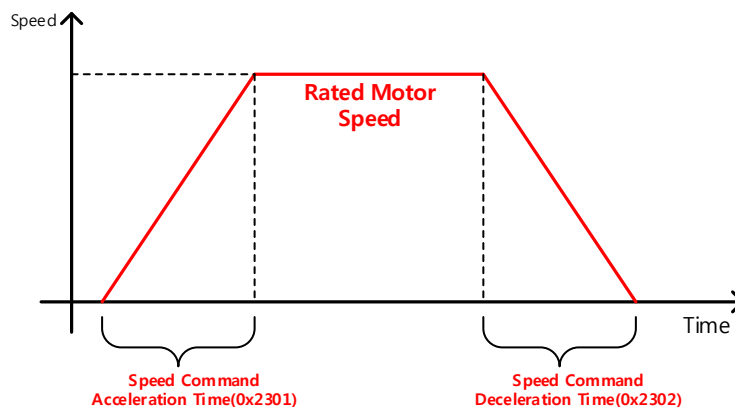

You can calculate the actual acceleration/deceleration time as shown below:

Acceleration time = speed command / rated speed x speed command acceleration time (0x2301)

Deceleration time = speed command / rated speed x speed command deceleration time (0x2302)

As shown in the figure below, you can generate an S-curve shaped acceleration/deceleration profile for driving by setting the speed command S-curve time (0x2303) to a value of 0 or more. Make sure to verify the relationship between the acceleration/deceleration time and the S-curve time.

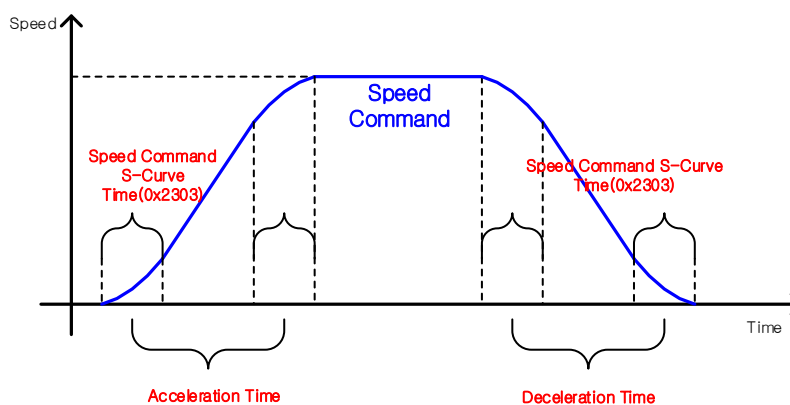

### 5.3.2 Servo-lock Function

During speed control operation, the servo position will not be locked even when 0 is entered for the speed command. This is due to the characteristic of speed control; at this time, you can lock the servo position by enabling the servo-lock function (0x2311).

Settings	Setting details
0	Servo-lock function disabled
1	Servo-lock function enabled

Using the servo-lock function, the position is internally controlled relative to the position at the time 0 is input as the speed command. If you input a speed command other than 0, the speed control will switch to normal mode.

### 5.3.3 Signals Related to Speed Control

As shown in the figure below, when the value of speed feedback is not more than the ZSPD output range (0x2404), a ZSPD (zero speed) signal will output; and when it is not less than the TGON output range (0x2405), a TGON (motor rotation) signal will output.

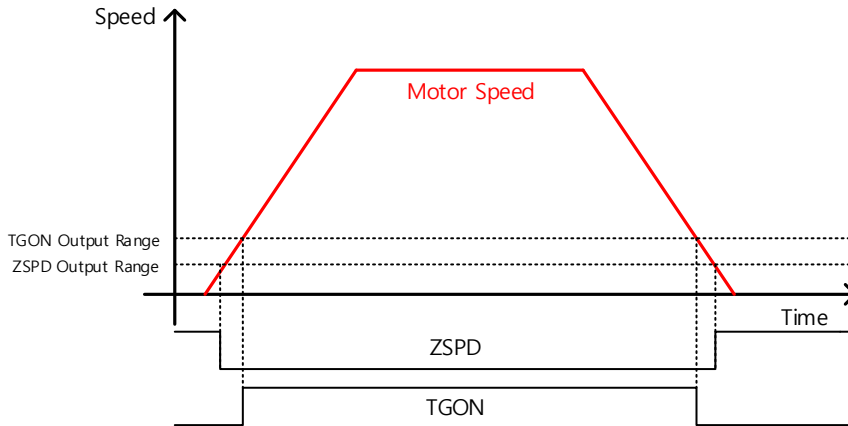

In addition, if the difference between the command and the speed feedback (i.e., speed error) is not more than the INSPD output range (0x2406), an INSPD (speed match) signal will output.

#### ■ Related Objects

Index	Sub Index	Name	Variable type	Accessibility	PDO Assignment	Unit
0x2404	-	ZSPD Ouput Range	UINT	RW	Yes	rpm
0x2405	-	TGON Ouput Range	UINT	RW	Yes	rpm
0x2406	-	INSPD Ouput Range	UINT	RW	Yes	rpm

## 5.4 Settings Related to Position Control

### 5.4.1 Position Command Filter

This section describes how to operate the drive more smoothly by applying a filter to the position command. For the purpose of filtering, you can set the position command filter time constant (0x2109) using the primary low pass filter and the position command average filter time constant (0x210A) using the moving average.

You can use a position command filter in the following cases:

- (1) If the electric gear ratio is 10 times or above

(2) If the acceleration/deceleration profile cannot be generated from the upper level controller

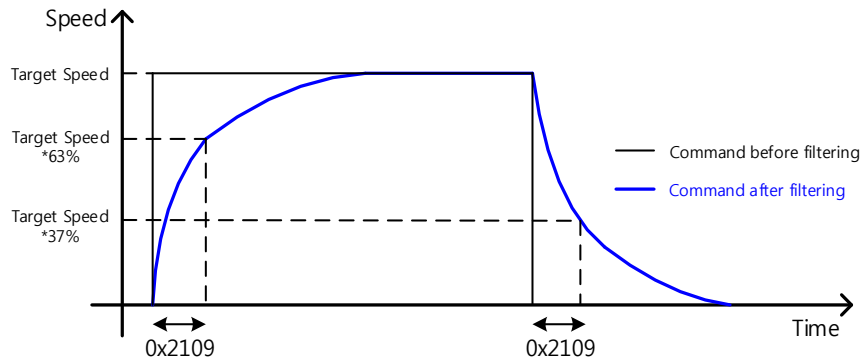

Position command filter using the position command filter time constant (0x2109)

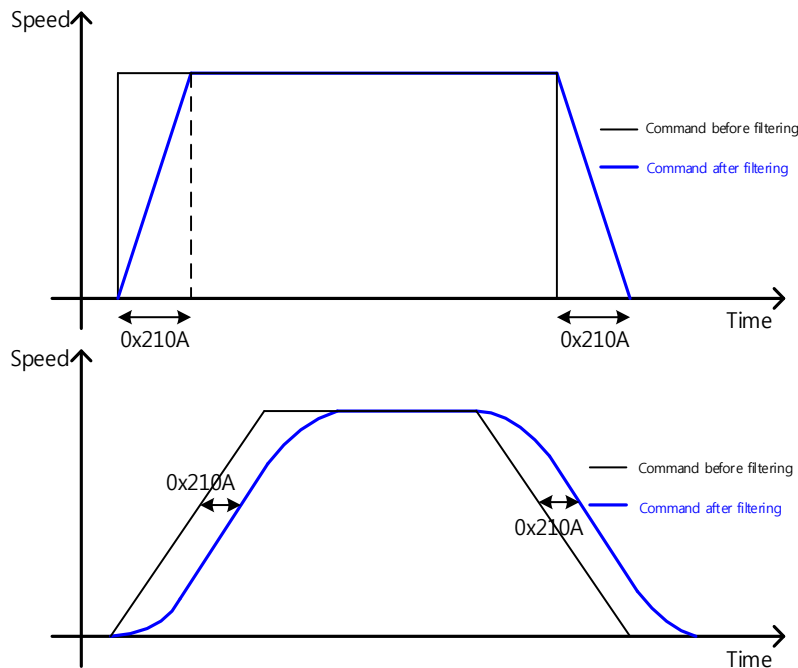

Position command filter using the position command average filter time constant (0x210A)

■ Related Objects

Index	Sub Index	Name	Variable type	Accessibility	PDO Assignment	Unit
0x2109	-	Position Command Filter Time Constant	UINT	RW	Yes	0.1ms
0x210A	-	Position Command Average Filter Time Constant	UINT	RW	Yes	0.1ms



### 5.4.2 Signals Related to Position Control

As shown in the figure below, if the value of the position error (i.e., the difference between the position command value input by the upper level controller and the position feedback value) is not more than the INPOS1 output range (0x2401), and is maintained for the INPOS1 output time (0x2402), the INPOS1 (position completed 1) signal will output, provided that the position command is not renewed.

If the position error value is not more than the INPOS2 output range (0x2403), the INPOS2 (position completed 2) signal will output, regardless of whether the position command has been renewed or not.

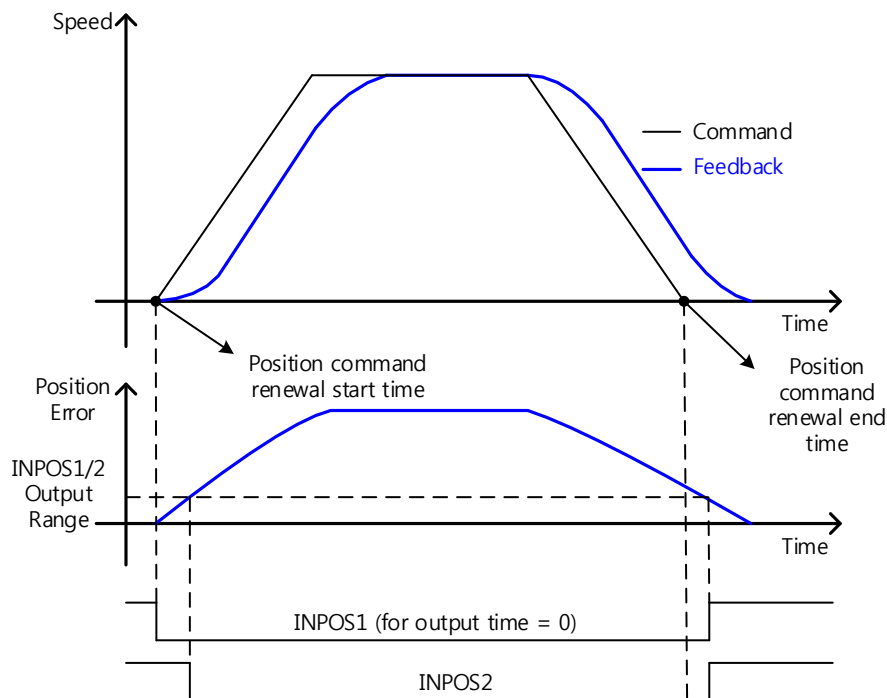

■ Related Objects

Index	Sub Index	Name	Variable type	Accessibility	PDO Assignment	Unit
0x2401	-	INPOS1 Ouput Range	UINT	RW	Yes	UU
0x2402	-	INPOS1 Ouput Time	UINT	RW	Yes	ms
0x2403	-	INPOS2 Ouput Range	UINT	RW	Yes	UU

## 5.5 Settings Related to Torque Control

### 5.5.1 Speed Limit Function

In torque control mode, the torque command input from the upper level controller controls the torque, but does not control the speed; thus, the apparatus might be damaged due to the exceedingly increased speed by an excessive torque command. To address this problem, this drive provides a function that limits motor speed based on the parameters set during torque control.

You can limit the speed using the maximum speed or the speed limit value (0x230E) according to the value of the speed limit function setting (0x230D), as described below. With the VLMT (speed limit) output value, you can verify whether the speed is limited.

Settings	Setting details
0	Limited by the speed limit value (0x230E)
1	Limited by the maximum motor speed

#### ■ Related Objects

Index	Sub Index	Name	Variable type	Accessibility	PDO Assignment	Unit
0x230D	-	Speed Limit Function Select	UINT	RW	No	-
0x230E	-	Speed Limit Value	UINT	RW	Yes	rpm

## 5.6 Positive/Negative Limit Settings

This function is to safely operate the drive within the movable range of the apparatus using the positive/negative limit signals of the drive. Be sure to connect and set the limit switch for safe operation. For more information about the settings, refer to 5.1.1 Assignment of Digital Input Signals.

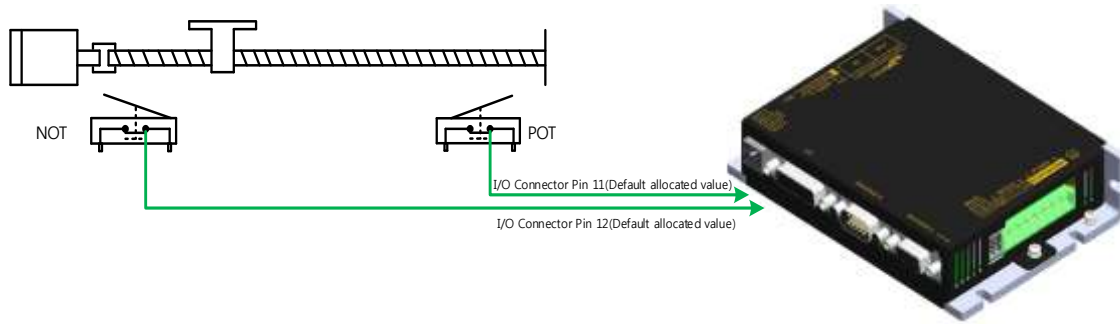

If the positive/negative limit signals are input, the motor will stop according to the emergency stop setting (0x2013).

Settings	Description
0	The motor will stop according to the method set in the dynamic brake control mode (0x2012). It will stop using the dynamic brake, and then maintain the torque command at 0.
1	Decelerates to a stop using the emergency stop torque (0x2113).

■ Related Objects

Index	Sub Index	Name	Variable type	Accessibility	PDO Assignment	Unit
0x2012	-	Dynamic Brake Control Mode	UINT	RW	No	-
0x2013	-	Emergency Stop Configuration	UINT	RW	No	-
0x2113	-	Emergency Stop Torque	UINT	RW	Yes	-

## 5.7 Setting the Brake Output Signal Function

If the motor stops because the servo turns off or a servo alarm occurs during rotation, you can set the speed (0x2407) and delay time (0x2408) for the brake signal output to configure the output timing.

The brake signal will be output if the motor rotation speed goes below the set speed (0x2407) or the output delay time (0x2408) has elapsed after the servo OFF command.

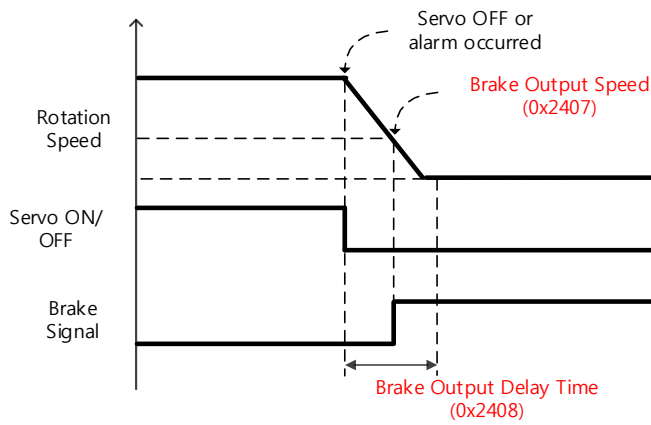

Timing diagram for signal output by the brake output speed (0x2407)

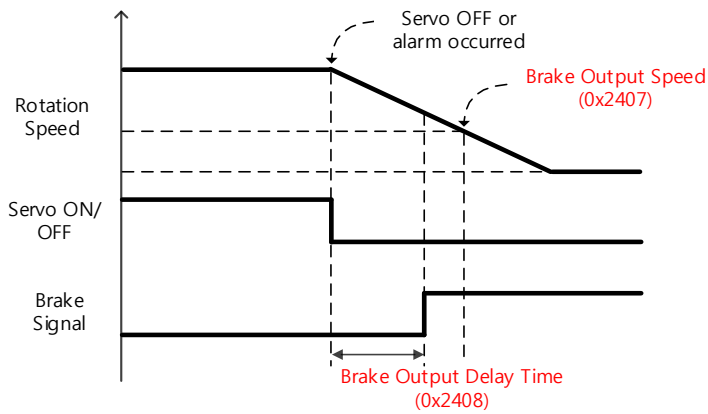

Timing diagram for signal output by the brake output delay time (0x2408)

When the servo is turned off or a servo alarm occurs, set the delay time until the actual PWM output turns off.

When using a motor with a brake installed on the vertical axis, you can output the brake signal first, and then turn off the PWM after this set time, to prevent it from running down along the axis.

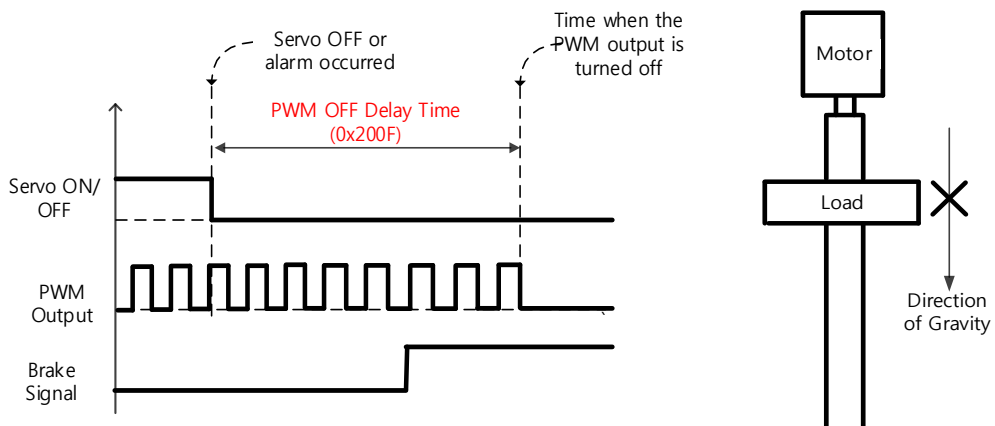

(1) If the brake signal outputs first before the PWM output turns off

You can output the brake signal first before the PWM output is turned off, preventing the drop along the vertical axis due to gravity.

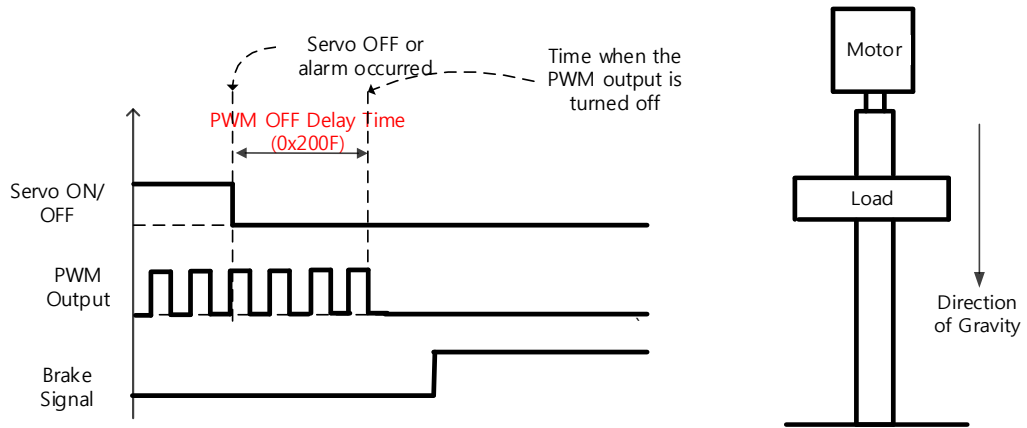

(2) If the PWM output turns off first before the brake signal outputs

The PWM output is turned off first before the brake signal outputs, allowing the drop along the vertical axis due to gravity.

## 5.8 Torque Limit Function

You can limit the drive output torque to protect the machine. It can be set by the torque limit function (0x2110). The setting unit of the torque limit value is 0.1%.

- Description of the torque limit function setting (0x2110)

Limit function	Description
Internal torque limit 1 (setting 0)	<p>Limits the torque using forward/reverse torque limit values according to the driving direction; the maximum value is limited by the maximum torque (0x6072).</p> <p>- Forward: 0x60E0, Reverse: 0x60E1</p>

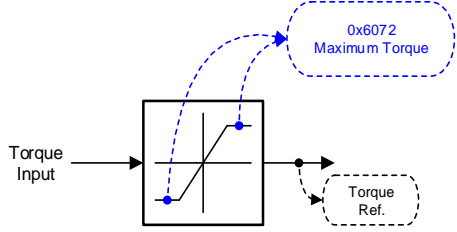
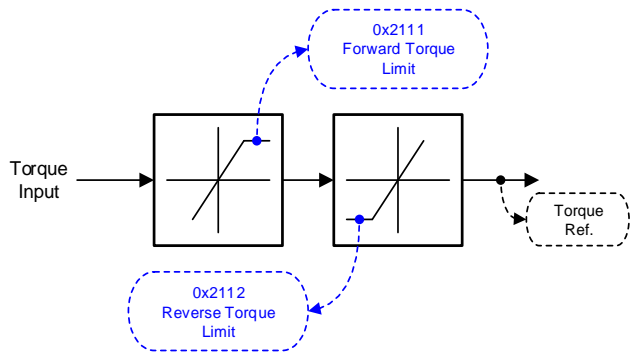
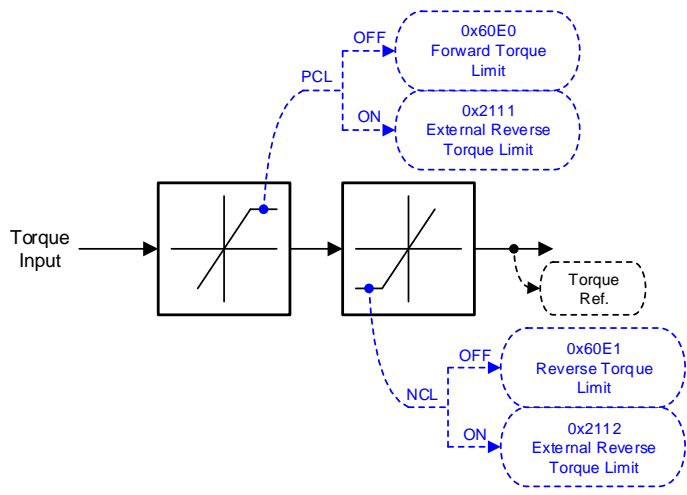
<p>Internal torque limit 2 (setting 1)</p>	 <p>Limits the torque by the maximum torque (0x6072) only regardless of the driving direction.</p>
<p>External torque limit (setting 2)</p>	 <p>Limits the torque using external forward/reverse torque limit values according to the driving direction.</p> <ul style="list-style-type: none"> <li>- Forward: 0x2111, Reverse: 0x2112</li> </ul>
<p>Internal and external torque limits (setting 3)</p>	 <p>Limits the torque using internal and external torque limit values according to the driving direction and the torque limit signal.</p> <ul style="list-style-type: none"> <li>- Forward: 0x60E0 (if PCL signal is not input), 0x2111 (if PCL signal is input)</li> <li>- Reverse: 0x60E1 (if NCL signal is not input), 0x2112 (if NCL signal is input)</li> </ul>

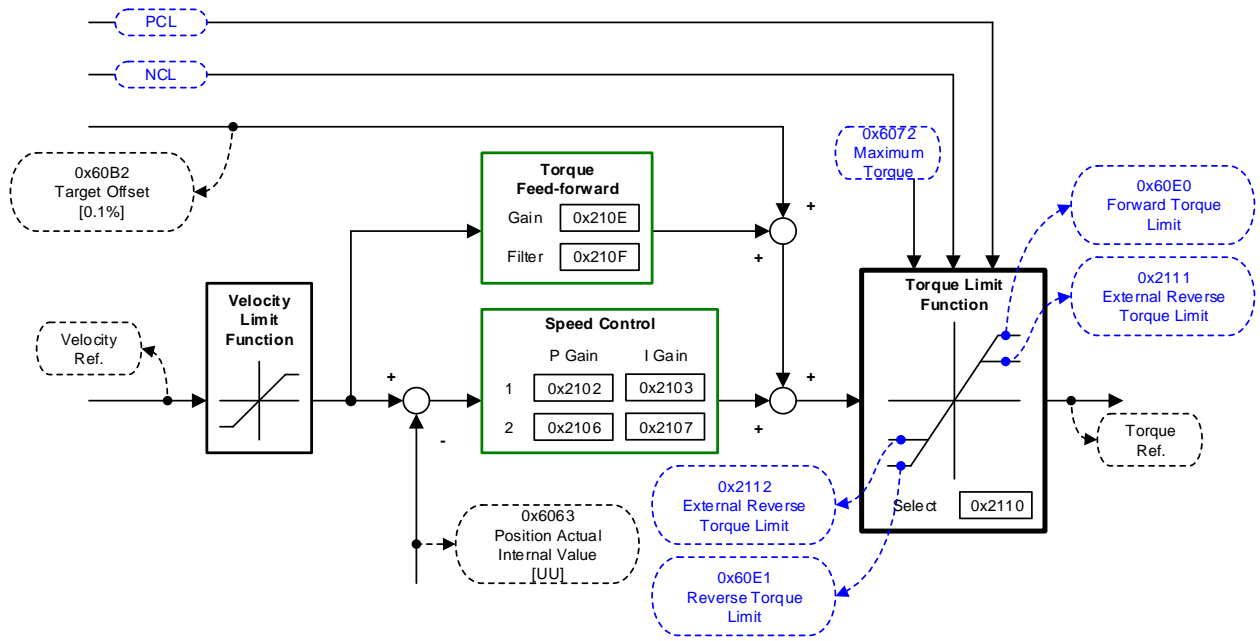

■ Related Objects

Index	Sub Index	Name	Variable type	Accessibility	PDO Assignment	Unit
0x2110	-	Torque Limit Function Select	UINT	RW	Yes	-
0x2111	-	External Positive Torque Limit Value	UINT	RW	Yes	0.1%
0x2112	-	External Negative Torque Limit Value	UINT	RW	Yes	0.1%
0x6072	-	Maximum Torque	UINT	RW	Yes	0.1%
0x60E0	-	Positive Torque Limit Value	UNIT	RW	Yes	0.1%
0x60E1	-	Negative Torque Limit Value	UINT	RW	Yes	0.1%

## 5.9 Gain Switching Function

### 5.9.1 Gain Group Switching

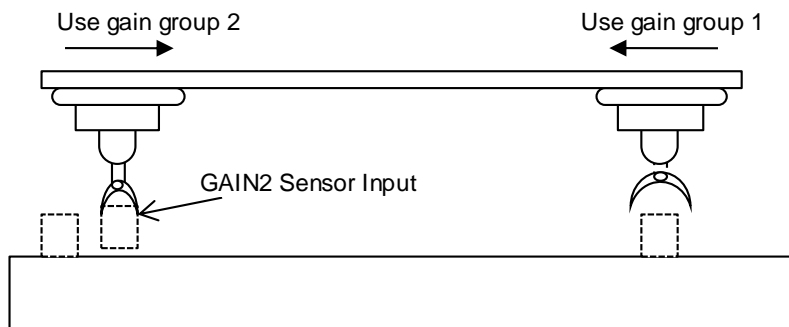

As one of the gain adjustment methods, this function is to switch between gain groups 1 and 2. You can reduce the time required for positioning through switching gains.

A gain group consists of the position loop gain, speed loop gain, speed loop integral time constant, and torque command filter time constant. The gain switching function (0x2119) can be set as follows:

- Description of gain switching function (0x2119)

Settings	Setting details
0	Only gain group 1 is used.
1	Only gain group 2 is used.
2	Gain is switched according to the GAIN2 input status. - 0: Use gain group 1 - 1: Use gain group 2
3	Reserved
4	Reserved
5	Reserved
6	Gain is switched according to the ZSPD output status. - 0: Use gain group 1 - 1: Use gain group 2
7	Gain is switched according to the INPOS1 output status. - 0: Use gain group 1 - 1: Use gain group 2

The waiting time and switching time for gain switching is as follows:

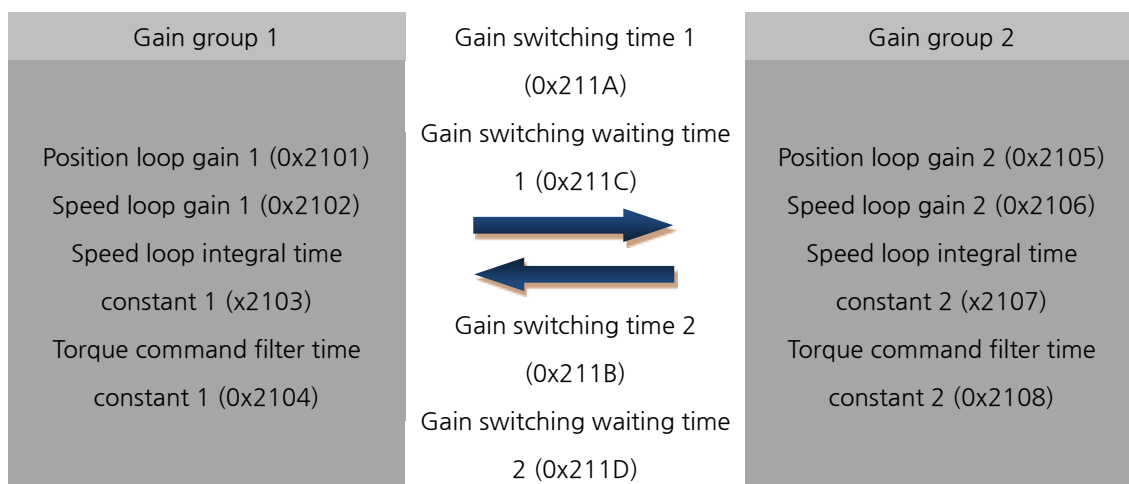



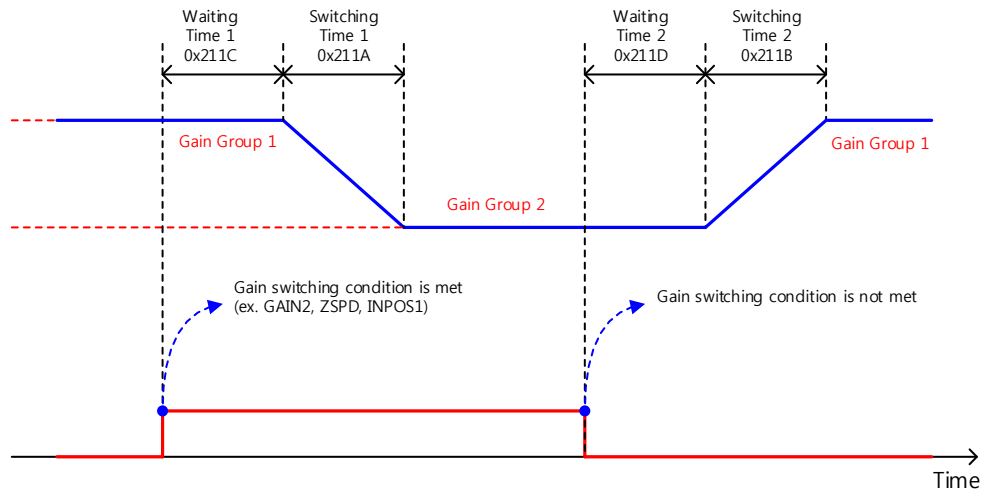

■ Related Objects

Index	Sub Index	Name	Variable type	Accessibility	PDO Assignment	Unit
0x2119	-	Gain Conversion Mode	UINT	RW	Yes	-
0x211A	-	Gain Conversion Time 1	UINT	RW	Yes	ms
0x211B	-	Gain Conversion Time 2	UINT	RW	Yes	ms
0x211C	-	Gain Conversion Waiting Time 1	UINT	RW	Yes	ms
0x211D	-	Gain Conversion Waiting Time 2	UINT	RW	Yes	ms

### 5.9.2 P/PI Control Switching

PI control uses both proportional (P) and integral (I) gains of the speed controller, while P control uses only the proportional gain.

The proportional gain determines the responsiveness of the entire controller, and the integral gain is used to eliminate an error in the steady state. Too high of an integral gain will result in an overshoot during acceleration or deceleration.

The PI/P control switching functions are used to switch between the PI and P controls under parametric conditions within the servo (such as torque, speed, acceleration, and position deviation); specifically, they are used in the following situations:

Speed control: To suppress any overshoot or undershoot during acceleration/deceleration.

Position control: To suppress undershoot during positioning, resulting in a reduced positioning time.

You can accomplish a similar effect by setting the acceleration/deceleration of the upper level controller, the soft start of the servo drive, the position command filter, etc.

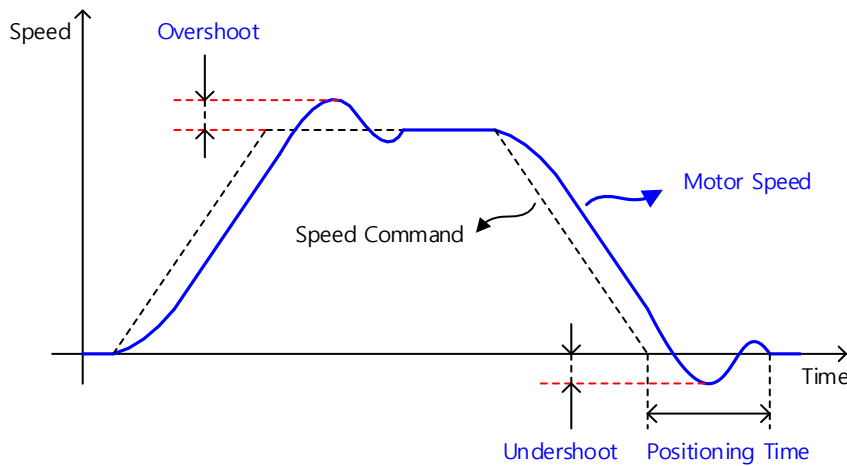

You can configure these settings in the P/PI control switching mode (0x2114). Please see the details below: Switching to P control by PCON input takes precedence over this setting.

Settings	Setting details
0	Always uses PI control.
1	Switches to P control if the command torque is larger than the P control switching torque (0x2115).
2	Switches to P control if the command speed is larger than the P control switching speed (0x2116).
3	Switches to P control if the acceleration command is larger than the P control switching acceleration (0x2117).
4	Switches to P control if the position error is larger than the P control switching position error (0x2118).

■ Related Objects

Index	Sub Index	Name	Variable type	Accessibility	PDO Assignment	Unit
0x2114	-	P/PI Control Conversion Mode	UINT	RW	Yes	-
0x2115	-	P Control Switch Torque	UINT	RW	Yes	0.1 %
0x2116	-	P Control Switch Speed	UINT	RW	Yes	rpm
0x2117	-	P Control Switch Acceleration	UINT	RW	Yes	rpm/s
0x2118	-	P Control Switch Following Error	UINT	RW	Yes	pulse

■ Example of P/PI Switching by Torque Command

When PI control is always used rather than P/PI control switching for speed control, the integral term of the acceleration/deceleration error is accumulated, resulting in an overshoot and an extended positioning time. At this time, you can reduce the overshoot and the positioning time using an appropriate P/PI switching mode. The figure below shows an example of switching mode by torque command:

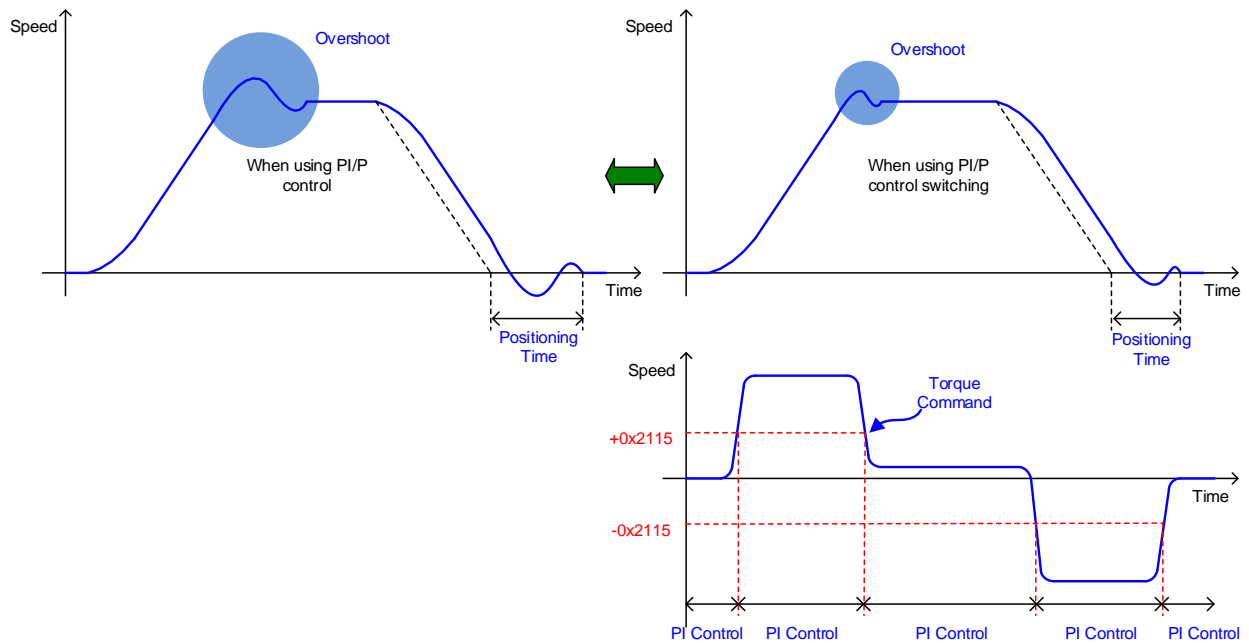

## 5.10 Motor Overload Prevention Function

In order to prevent motor damage due to overheating, the motor overload prevention function by algorithm or by motor thermal time constant is provided.  $I^2T$

### 5.10.1 $I^2T$ Prevention by Algorithm

It traces the current flow from the drive and blocks the motor current output when the estimated motor temperature exceeds the standard. This function should be set correctly since it is calculated based on the motor parameter [0x2000] or 3<sup>rd</sup> party motor parameters [0x2802] and [0x2803], and the operating time at the maximum current [0x2031].

For example, let's assume that the motor specifications are as follows.

Motor rated current: 3 A  
 Motor maximum current: 9 A  
 Operating time at maximum current: 1000 ms

Drive output current ( $I_{out}$ ) : 6 A

$$I^2T_{Limit} = ((9A)^2 - (3A)^2) \times 1000ms = 72000A^2ms$$

$$T_{LMT} = \frac{I^2T_{Limit}}{I_{out}^2 - (3A)^2} = \frac{72000A^2ms}{(6A)^2 - (3A)^2} = 2666ms$$

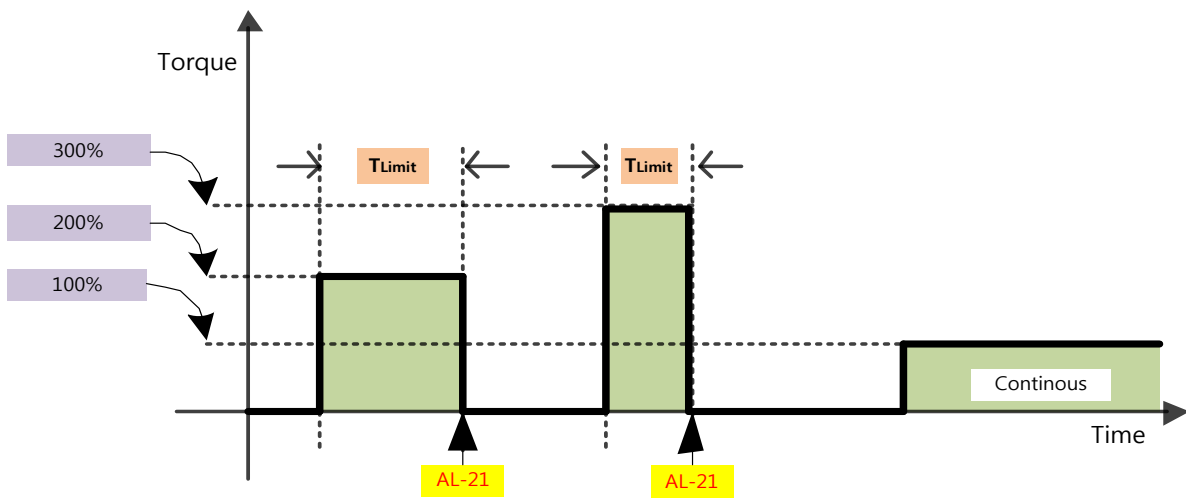

Related Objects

Index	Sub Index	Name	Variable type	Accessibility	PDO Assignment	Unit
0x2000	-	Motor ID	UINT	RW	No	-
0x2031	-	Operation Time at Peak Current	UINT	RW	No	ms
0x2802	-	[3rd Party Motor] Rated Current	FP32	RW	No	Arms
0x2803	-	[3rd Party Motor] Maximum Current	FP32	RW	No	Arms

### 5.10.2 Prevention by Motor Thermal Time Constant

It estimates the motor temperature based on the relationship between motor winding and ambient temperature. If the temperature exceeds the standard, it blocks motor current output. This function is activated when the motor heat prevention function activation [0x2034] parameter is set to 1. It should be set correctly since it is calculated based on the motor thermal time constant [0x2034].

The formula for calculating the motor thermal time constant is shown below.

$$\text{Thermal time constant}[\text{sec}] = \text{Thermal resistance} \left[ \frac{^{\circ}\text{C}}{\text{watt}} \right] \times \text{Thermal capacitance} \left[ \text{watt} \times \frac{\text{sec}}{^{\circ}\text{C}} \right]$$

■ Related Objects

Index	Sub Index	Name	Variable type	Accessibility	PDO Assignment	Unit
0x2034	-	Motor Thermal Protection Enable	UINT	RW	No	-
0x280D	-	[3 <sup>rd</sup> Party Motor]Thermal Time Constant	FP32	RW	No	°C /watt

## 5.11 Configuration of the Drive Node Address (ADDR)

Configure the drive node address. You can verify the set address in the node ID (0x2003). The value of the node setting switch is read just once when the power is turned on. Any subsequently modified settings will only take effect when the power is turned off and then turned on again.

Since there are 7 switches that can be set independently, you can set the node address between 0 and 127.

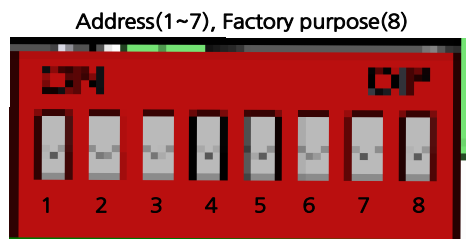

Note: For more information about how the master reads the node address of the EtherCAT drive, refer to 18.4.1 Requesting ID in the document titled "ETG.1020 EtherCAT Protocol Enhancements."

⚠ Perform the rotary switch operation for the node ID setting only when drive power is not applied.

⚠ Switch no. 8 is reserved for the manufacturer so you should not touch the switch.

## 6. Safety Functions

This servo drive has a built-in safe torque off (STO) function to reduce the risks associated with using the machine by protecting people from the dangerous operation of moveable parts. In particular, this function can be used to prevent the dangerous operation of the machine's moveable parts when you need to perform tasks such as maintenance in a danger zone.

### 6.1 Safe Torque Off (STO) Function

The safe torque off (STO) function blocks the motor current according to the input signal transferred from a safety device connected to the connector, such as a safety controller or safety sensor, to stop the motor.

#### ■ Safe Torque Off Operation State According to STO Input Contact

Signal Name	Function			
	STO1	ON	ON	OFF
STO2	ON	OFF	ON	OFF
Operation state	Normal state	STO state	STO state	STO state

#### ■ Electric Characteristics

- STO1, STO2

Item	Characteristic value
Internal impedance	2.49 kΩ
Voltage input range	DC 12 ~ 30 V
Maximum delay time	1 ms or less

■ Timing Diagram for STO Operation

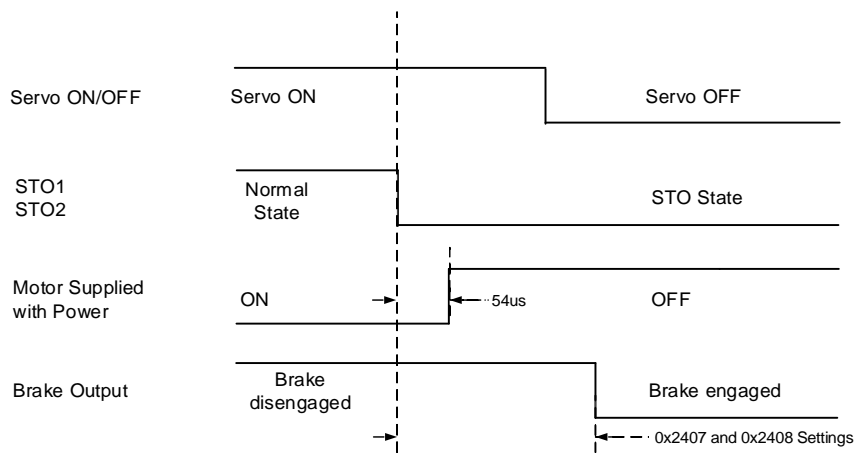

Note 3) If either STO1 or STO2 is turned off, the drive state is switched to the STO state.

Note 4) Whichever is the earlier time, out of the points of time until the value becomes less than the setting value of the brake output delay time [0x2408] or less than the brake output speed [0x2407], will be applied.

■ Timing Diagram for STO Recovery

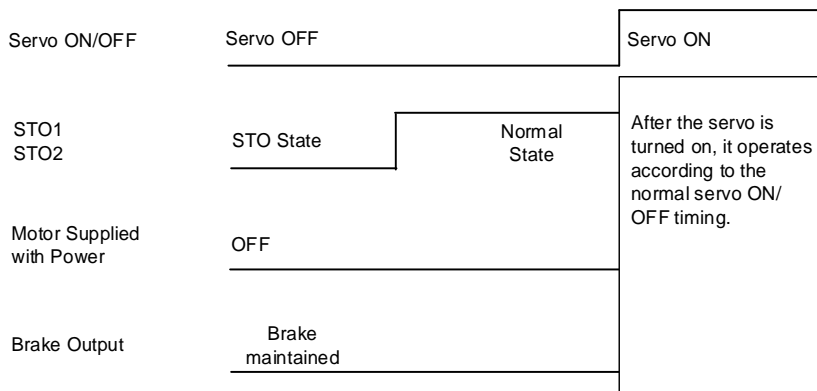

Note 5) Be sure to recover the STO1 and STO 2 input signals to On in the Servo Off state. It is not necessary to reset the alarm separately since the "STO state" is not an alarm state.

## 6.2 Example of Using the Safety Function

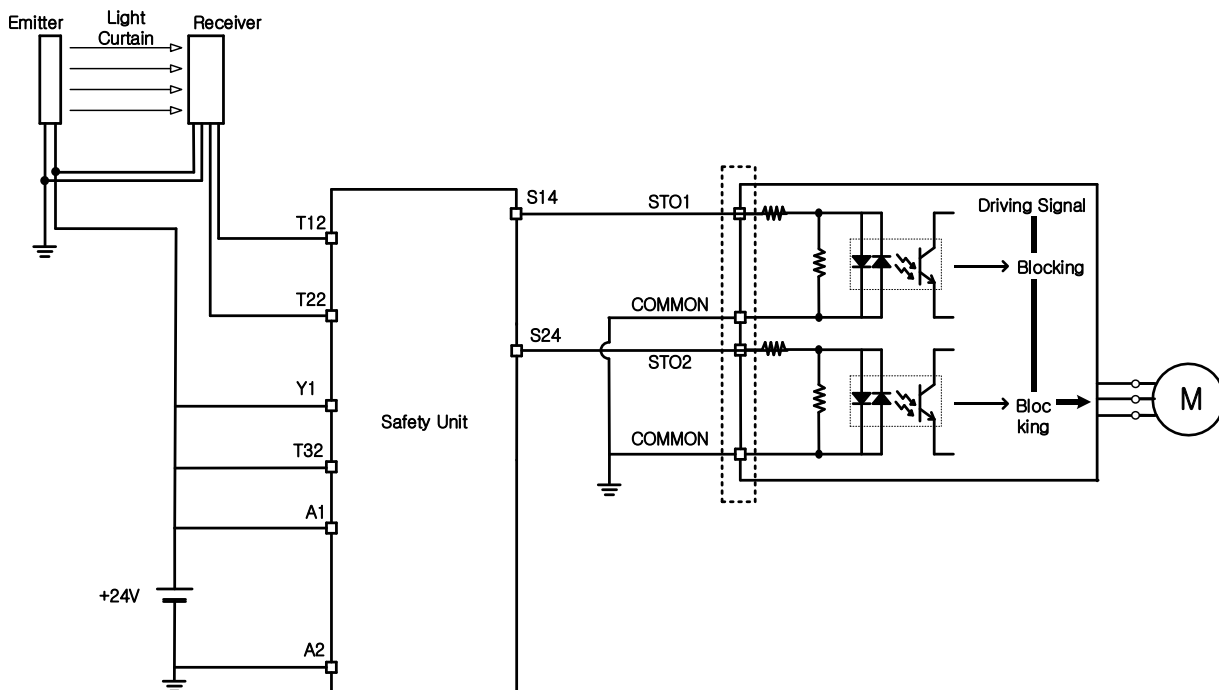

## 6.3 How to Verify the Safety Function

In case the servo drive was replaced prior to starting up the device or during maintenance, make sure to check the details below:

- When the STO1 and STO2 signals are turned off, check if the drive is in STO status (Bit 31 for digital input (0x60FD) is 1).

## 6.4 Precautions for Using the Safety Function

- When using the STO function, be sure to carry out risk assessments for the device to check if the system safety requirements are met.
- There may be risks even if the STO function works.
- In the STO state, the motor is operated by an external force; thus, if the load needs to be maintained, arrange a separate measure such as an external mechanical brake. The brake of the servo system is dedicated for maintaining the load; thus, be careful not to use it to brake the motor.
- If no external force is applied, keep in mind that the load moves freely and the stop distance of the load becomes longer.



- The purpose of the STO function is not to block the servo drive power or electrically insulate the drive. That is why you have to disconnect the servo drive power before carrying out maintenance of any sub-drive.

# 7. Tuning

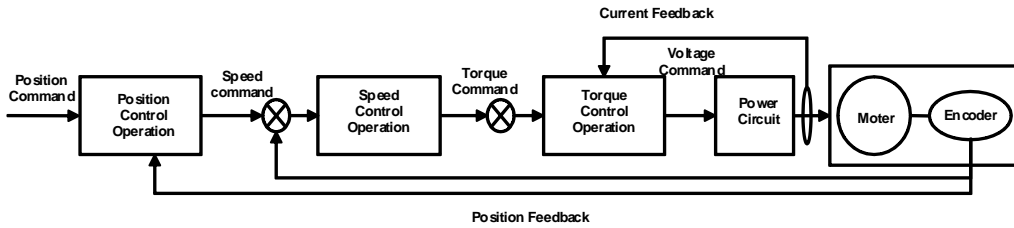

The drive is set to torque control, speed control, or position control mode for use, depending on the method used to connect with the upper level controller. This drive is structured so that the position control is located at the outer position while the current control at the inner position, forming a cascade-type control structure. Depending on the operation mode of the drive, you can tune the operation by setting the gain-related parameters of the torque controller, the speed controller, and the position controller to satisfy your purpose.

## 7.1 Offline Auto Gain Tuning

Use the command generated by the drive itself to automatically set the gain according to the load condition. The following gain-related parameters will be changed:

- Inertia ratio, position loop gain, speed loop gain, speed integral time constant, torque command filter time constant, notch filter 3 frequency, and notch filter 4 frequency

The overall gain is set higher or lower depending on the system rigidity setting (0x250E) during gain tuning. Set the appropriate value depending on the rigidity of the driven load.

As shown in the figure below, the sinusoidal-type command is generated in the forward or reverse direction according to the offline gain tuning direction (0x2510) setting. You can set the moving distance for tuning with the offline gain tuning distance (0x2511). The larger the setting value is, the longer the moving distance becomes. Set the distance appropriately for the case. Make sure to secure enough distance (more than one motor revolution) prior to gain tuning.

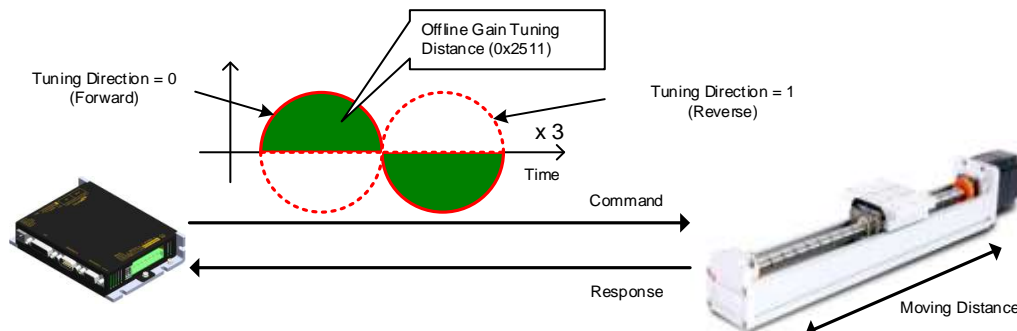

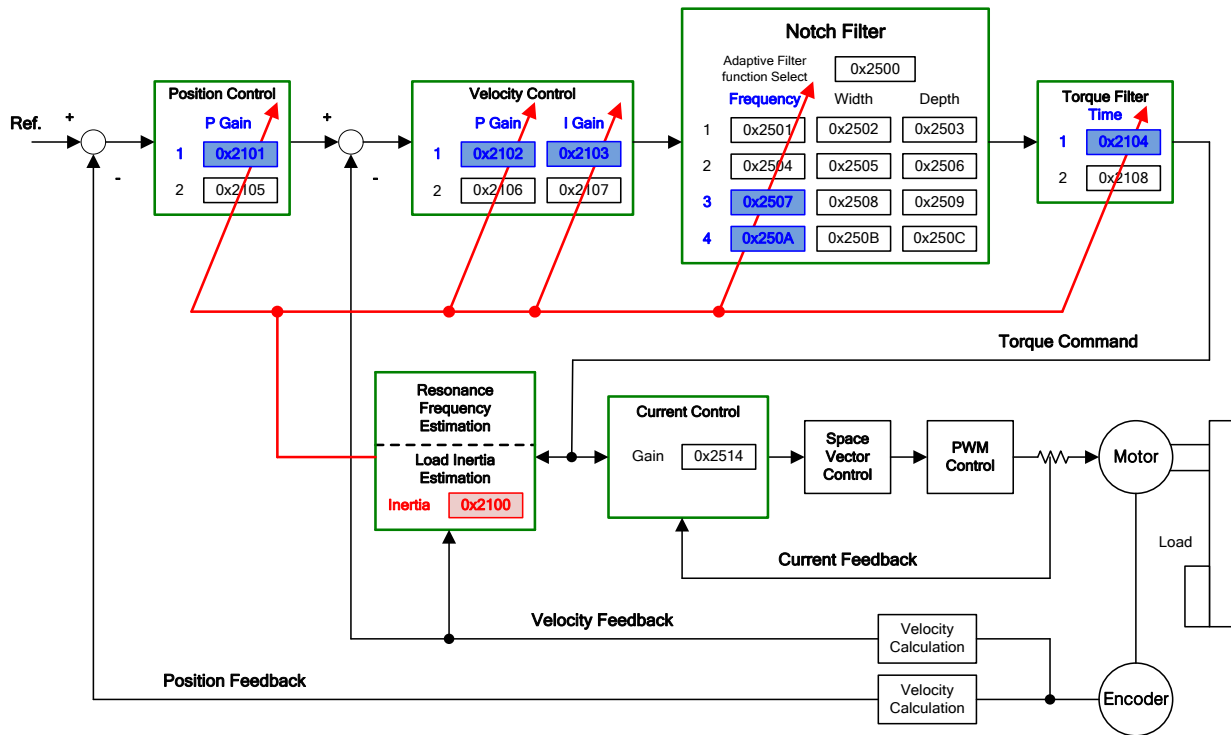

■ Related Objects

Index	Sub Index	Name	Variable type	Accessibility	PDO Assignment	Unit
0x250E		System Rigidity for Gain Tuning	UINT	RW	No	-
0x2510	-	Off-line Gaing Tuning Direction	UINT	RW	No	-
0x2511		Off-line Gain Tuning Distance	UINT	RW	No	-

## 7.2 Online Auto Gain Tuning

It does not use offline auto tuning that is generated by the drive, but receives a command from an upper level unit to automatically set the parameters related to gains based on system inertia, the rigidity set by the user, and other general rules.

- Inertia ratio, position loop gain, speed loop gain, speed integral time constant, torque command filter time constant

Online tuning is carried out based on the gain table values that are divided into 20 levels based on the rigidity. The tuning results are regularly applied and the changed gains are saved on EEPROM every 2 minutes.

When estimating the inertia, the estimated results are applied quickly or slowly depending on the adaptation speed setting. The responsiveness of the overall system can be determined with the rigidity parameter.

In the following cases, incorrect inertia ratio may be estimated during online auto tuning.

- When the load change is excessive
- In the case of a system with too much backlash or excessively low rigidity of the load
- When the load is too small (3 times or below) or too large (20 times or above)
- When the acceleration/deceleration torque is not sufficient as acceleration and deceleration are too small (10% of the rating or less)
- When rotation speed is low (10% of the rating or less)
- When friction torque is high

If normal inertia is not estimated due to the above conditions or during online auto tuning, carry out offline gain tuning.

#### ■ Parameters that Change after Tuning

- Inertia ratio (0x2100), position loop gain 1 (0x2101), speed loop gain 1 (0x2102), speed integral time constant 1 (0x2103), torque command filter time constant 1 (0x2104)
- Notch filter 3, 4 frequency (0x2507, 0x250A) → Refer to the auto notch setting function

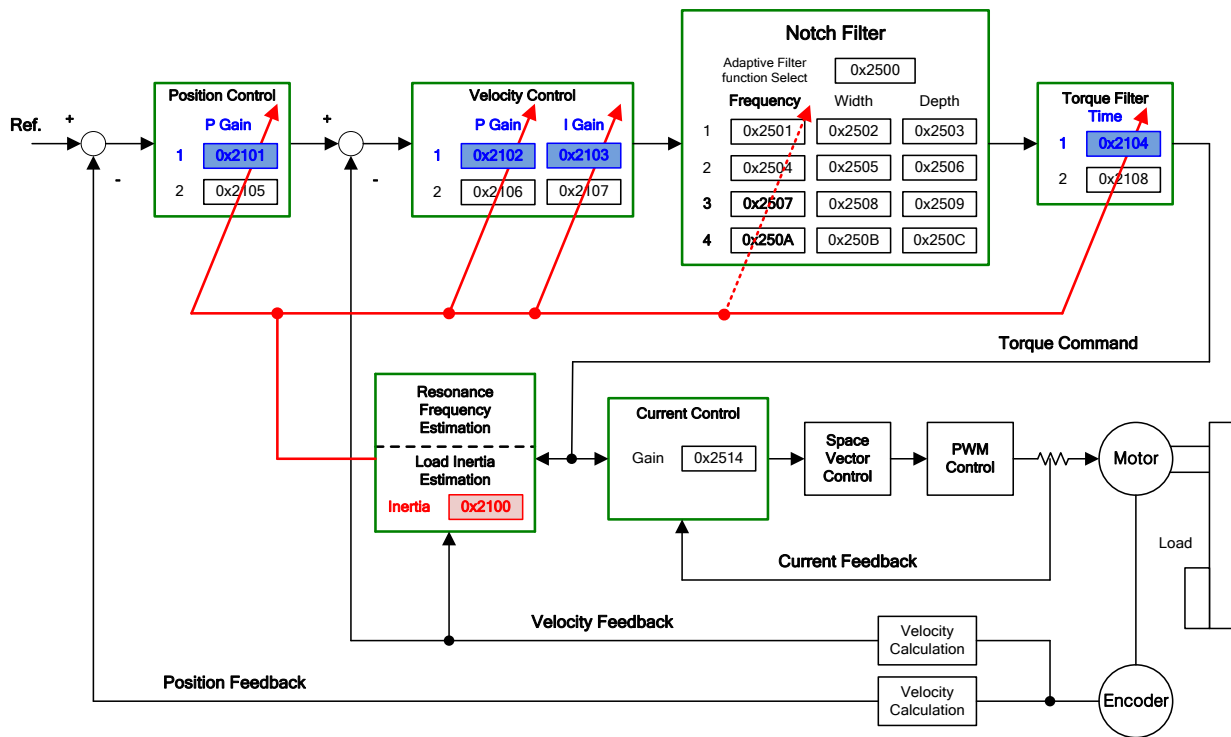

■ Related Objects

Index	Sub Index	Name	Variable type	Accessibility	PDO Assignment	Unit
0x250D		On-line Gain Tuning Mode	UINT	RW	No	-
0x250E		System Rigidity for Gain Tuning	UINT	RW	No	-
0x250F		On-line Tuning Adaptation Speed	UINT	RW	No	-

## 7.3 Manual Gain Tuning

### 7.3.1 Gain Tuning Sequence

For a cascade-type controller, tune the speed controller gain located at the inner position first, and then tune the position controller gain located at the outer position.

In other words, tune the gains in the following order: proportional gain → integral gain → feedforward gain.

The role of each individual gain is as follows:

- Proportional gain: Determines the controller BW.
- Integral gain: Determines the steady-state error, and generates an overshoot.

- Feedforward gain: Enhances the system lag characteristic.
- Differential gain: Plays the role of damper for the system (not provided)

#### ■ Speed Controller Tuning

##### (1) Inertia ratio setting

- Use the automatic inertia estimation function or carry out manual setting.

##### (2) Proportional gain setting

- Monitor torque and noise before any vibration occurs.

##### (3) Integral gain setting

- Monitor the speed overshoot and the steady-state error.
- You can use the P/PI switching mode if you want to increase the integral gain but overshoot occurs.
- For this drive, the integral gain is set to the integral time constant.

##### (4) Speed command filter and speed feedback filter setting

#### ■ Position Controller Tuning

##### (1) Proportional gain setting

- Monitor torque, position error, and noise before any vibration occurs.

##### (2) Feedforward setting

- Position error monitoring
- Able to set the feedforward filter.
- Set the filter if you want to increase the feedforward value but noise occurs.
- You can set the feedforward value from 0% to 100%, which is the ratio of the position command value currently being entered and the deviation.

##### (3) Able to set the position command filter

- You can smooth out the position command.

## 7.4 Vibration Control

### 7.4.1 Notch Filter

A notch filter is a band-stop filter to eliminate specific frequency component. You can use a notch filter to eliminate the resonant frequency component of an apparatus, thereby avoiding vibrations while setting a higher gain.

This drive provides notch filters with 4 steps in total. You can set the frequency, width, and depth for each filter. You can use one or two notch filters as an adaptive filter, setting the frequency and the width automatically through real-time frequency analysis (FFT).

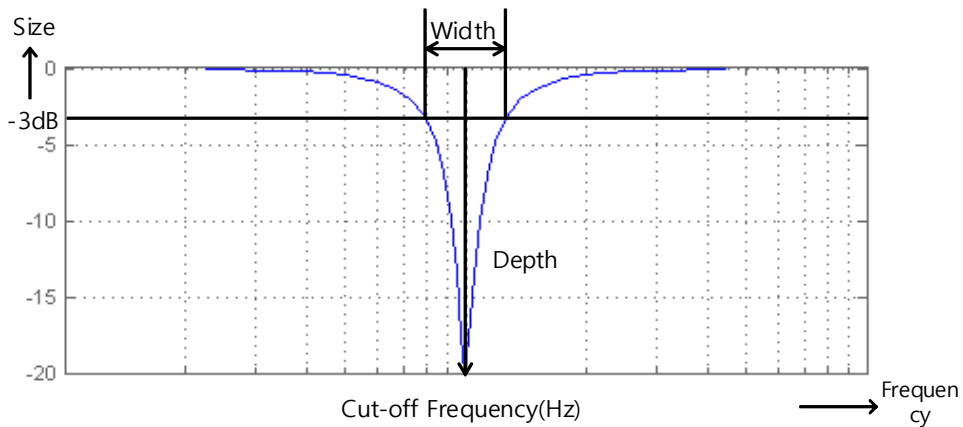

#### ■ Related Objects

Index	Sub Index	Name	Variable type	Accessibility	PDO Assignment	Unit
0x2501	-	Notch Filter 1 Frequency	UINT	RW	No	Hz
0x2502	-	Notch Filter 1 Width	UINT	RW	No	Hz
0x2503	-	Notch Filter 1 Depth	UINT	RW	No	-
0x2504	-	Notch Filter 2 Frequency	UINT	RW	No	Hz
0x2505	-	Notch Filter 2 Width	UINT	RW	No	Hz
0x2506	-	Notch Filter 2 Depth	UINT	RW	No	-
0x2507	-	Notch Filter 3 Frequency	UINT	RW	No	Hz
0x2508	-	Notch Filter 3 Width	UINT	RW	No	Hz
0x2509	-	Notch Filter 3 Depth	UINT	RW	No	-
0x250A	-	Notch Filter 4 Frequency	UINT	RW	No	Hz
0x250B	-	Notch Filter 4 Width	UINT	RW	No	Hz

0x250C	-	Notch Filter 4 Depth	UINT	RW	No	-
--------	---	----------------------	------	----	----	---

### 7.4.2 Adaptive Filter

An adaptive filter analyzes the real-time frequency of the vibration frequency, generated from the load during drive operation, through the speed feedback signal and automatically configures a notch filter to reduce vibrations.

It can detect the vibration frequency through frequency analysis to automatically configure one or two notch filters. At this time, the frequency and width are automatically set and the depth setting value is used as it is.

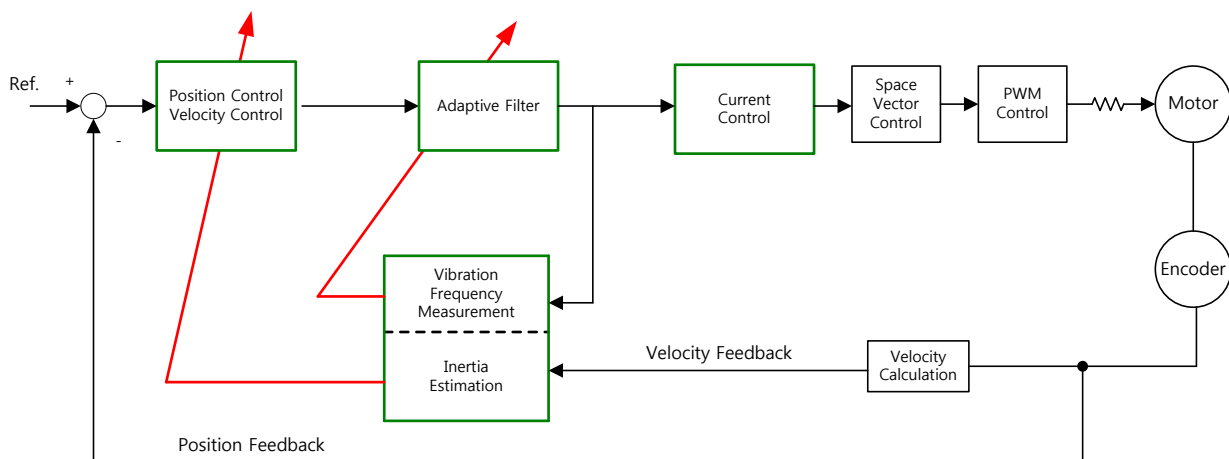



■ Related Objects

Index	Sub Index	Name	Variable type	Accessibility	PDO Assignment	Unit
0x2500	-	Adaptive Filter Function Select	UINT	RW	No	-

- Adaptive filter function setting (0x2500)

Settings	Setting details
0	Adaptive filter is not used.
1	Only one adaptive filter is used. You can check the settings configured automatically in the notch filter 3 settings (0x2507, 0x2508, 0x2509). If an arbitrary value is set in notch filter 3, auto setting is not available. If you wish to use auto setting, you should initialize notch filter 3 first.
2	Two adaptive filters are used. You can check the settings configured automatically in the notch filter 3 (0x2507, 0x2508, 0x2509) and filter 4 settings (0x250A, 0x250B, 0x250C). If an arbitrary value is set for notch filter 3 (or 4), auto setting is applied to notch filter 4 (or 3). If arbitrary values are set for notch filter 3 and 4, the original settings remain unchanged. If notch filter 3 and 4 are initialized, auto setting is available.
3	Reserved
4	Resets the notch filter 3 (0x2507, 0x2508) and notch filter 4 (0x250A, 0x250B, 0x250C) settings.
5	Reserved

### 7.4.3 Vibration Control (Damping) Filter

A vibration control (damping) filter can reduce the vibrations that occur in the load.

It measures the vibration frequency generated for the load using an external sensor. It uses the measurement as data for the objects related to the vibration control (damping) filter. This drive provides vibration control filters with 2 steps in total. You can set the frequency and damping amount for each filter.

It controls the low frequency range (1Hz -100 Hz) that is generated from the top of the device or the overall system. It can only operate in position control mode.

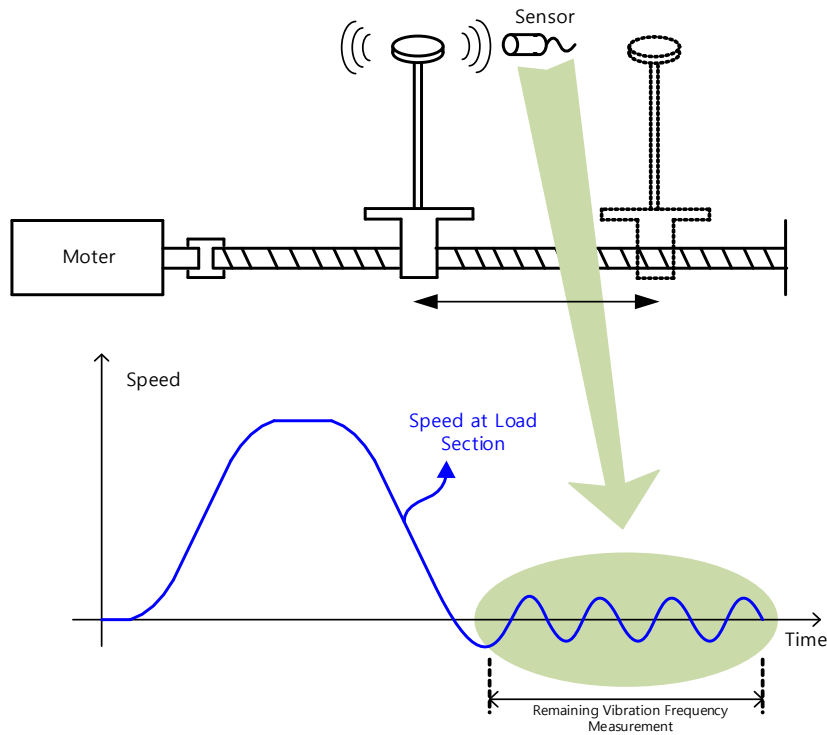

■ Related Objects

Index	Sub Index	Name	Variable type	Accessibility	PDO Assignment	Unit
0x2515	-	Vibration Suppression Filter Configuration	UINT	RW	No	-
0x2516	-	Vibration Suppression Filter 1 Frequency	UINT	RW	No	0.1 [Hz]
0x2517	-	Vibration Suppression Filter 1 Damping	UINT	RW	No	-
0x2518	-	Vibration Suppression Filter 2 Frequency	UINT	RW	No	0.1 [Hz]
0x2519	-	Vibration Suppression Filter 2 Damping	UINT	RW	No	-

- Vibration control filter function setting (0x2515)

Settings	Setting details
0	Vibration control (damping) filter is not used.
1	Vibration control (damping) filter is used.

## 7.5 Analog Monitor

Two channels of analog monitor outputs are provided to adjust drive gain or monitor internal status variables.

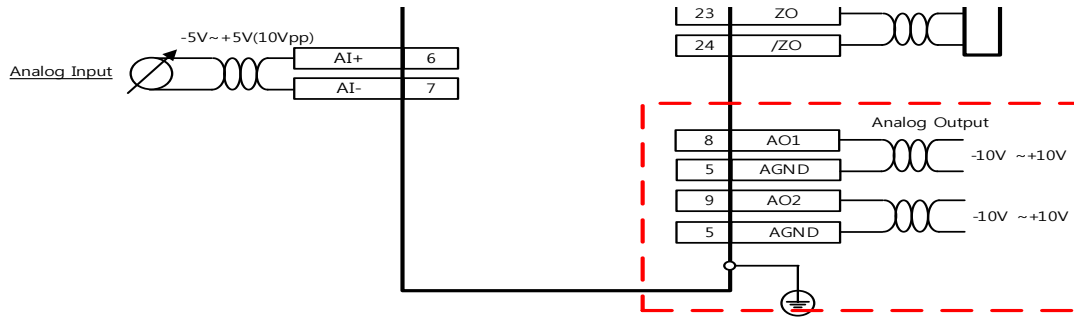

■ Related Objects

Index	Sub Index	Name	Variable type	Accessibility	PDO Assignment	Unit
0x2220	-	Analog Monitor Output Mode	UINT	RW	No	-
0x2221	-	Analog Monitor Channel 1 Select	UINT	RW	No	-
0x2222	-	Analog Monitor Channel 2 Select	UINT	RW	No	-
0x2223	-	Analog Monitor Channel 1 Offset	DINT	RW	No	-
0x2224	-	Analog Monitor Channel 2 Offset	DINT	RW	No	-
0x2225	-	Analog Monitor Channel 1 Scale	UDINT	RW	No	-
0x2226	-	Analog Monitor Channel 2 Scale	UDINT	RW	No	-

- Analog monitor output mode settings (0x2220)

The output range of the analog monitor is  $\pm 10$  V. If the setting is 1, take the absolute value of the output so the output values is only positive.

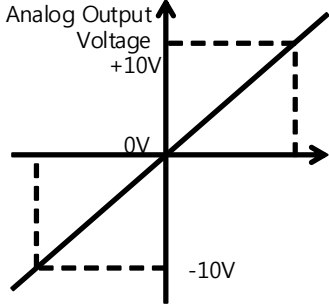
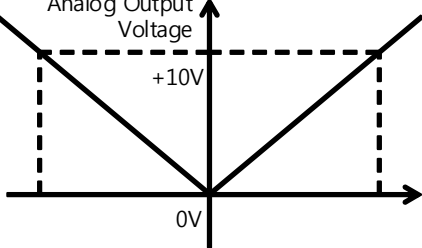
Settings	Details	Description
0	Output as negative/positive values	 <p>Analog Output Voltage</p> <p>+10V</p> <p>0V</p> <p>-10V</p>
1	Output only positive values	 <p>Analog Output Voltage</p> <p>+10V</p> <p>0V</p>

- Analog monitor channel 1 setting (0x2221)

This configures the monitoring variables to be output to analog monitor output channel 1.

Settings	Displayed item	Unit
0	Speed feedback	rpm
1	Speed command	rpm
2	Speed error	rpm
3	Torque feedback	%
4	Torque command	%
5	Position error	pulse
6	Accumulated operation overload	%
7	DC link voltage	V
8	Reserved	
9	Encoder single-turn data	pulse
10	Inertia ratio	%
11	Following Error Actual Value	UU
12	Drive temperature 1	°C
13	Drive temperature 2	°C
14	Encoder temperature	°C
15	Hall sensor signal	
16	U-phase current	A
17	V-phase current	A
18	W-phase current	A
19	Position actual value	UU
20	Position demand value	UU
21	Position command speed	rpm

22	Hall U Value	
23	Hall V Value	
24	Hall W Value	

The voltage is calculated as shown below during the analog monitor output:

$$\text{Output voltage for channel 1 (V)} = [\text{Monitoring signal value (0x2221)} - \text{Offset (0x2203)}] / \text{Scale (0x2205)}$$

$$\text{Output voltage for channel 2 (V)} = [\text{Monitoring signal value (0x2222)} - \text{Offset (0x2204)}] / \text{Scale (0x2206)}$$

■ **Setting Example**

The following shows an example of monitoring ripples during the 1000 rpm operation of a speed feedback signal:

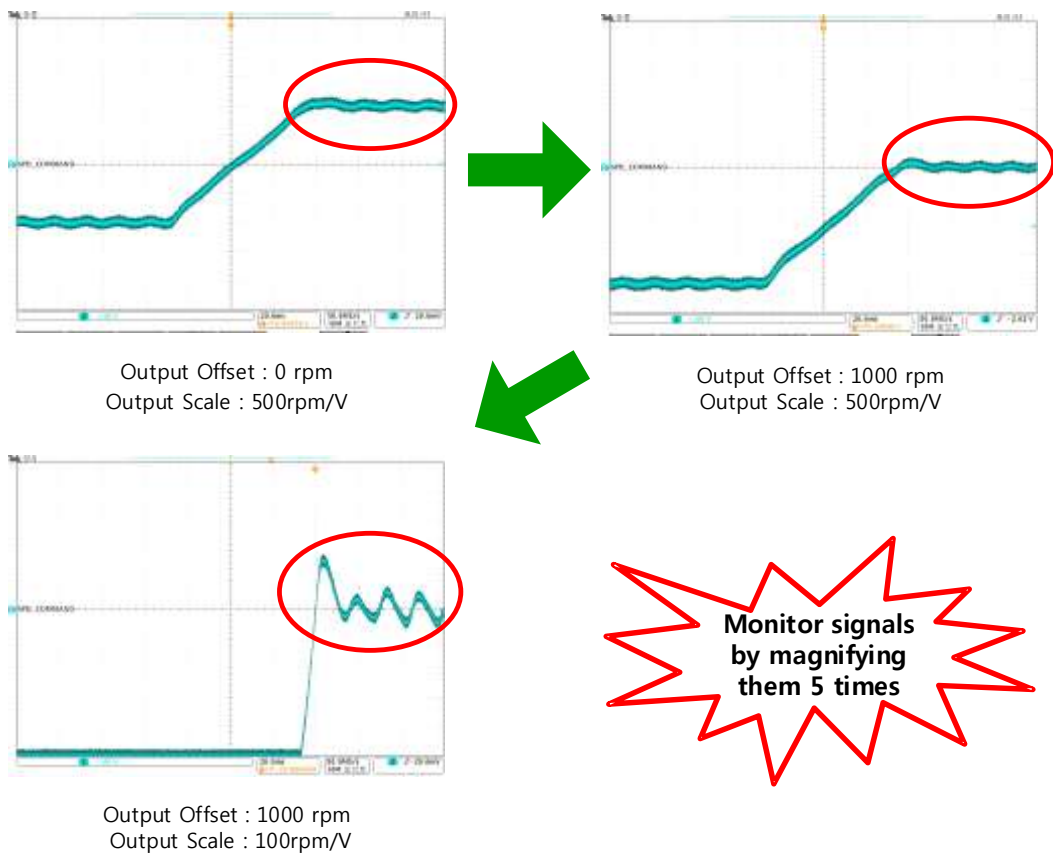

## 8. Procedure Function

The procedure function is an auxiliary function provided by the drive as described below. It can be executed by the procedure command code (0x2700) and procedure command factor (0x2701). It can be activated using the servo setting tool.

Procedure command	Code	Details
Manual JOG	0x0001	Manual jog operation
Program JOG	0x0002	Programmed jog operation
Alarm History Reset	0x0003	Deleting alarm history
Off-Line Auto-Tuning	0x0004	Offline auto-tuning
Index Pulse Search	0x0005	Phase Z position search
Absolute Encoder Reset	0x0006	Absolute encoder reset
Max. Load Torque Clear	0x0007	Instantaneous maximum operation overload value reset (0x2604)
Calibrate Phase Current Offset	0x0008	Phase current offset tuning
Software Reset	0x0009	Software reset
Commutation	0x000A	Commutation

### 8.1 Manual Jog Operation

A jog operation is a function that verifies the servo motor operation by speed control without an upper level controller.

Before starting the jog operation, make sure of the following:

- The main power is turned on;
- the STO (Safety Torque Off) connector is connected;
- no alarms go off;
- the servo is turned off;
- the operation speed is set with consideration to the apparatus state.

#### ■ Related Objects

Index	Sub Index	Name	Variable type	Accessibility	PDO Assignment	Unit
0x2300	-	Jog Operation Speed	INT	RW	No	rpm

0x2301	-	Speed Command Acceleration Time	UINT	RW	No	ms
0x2302	-	Speed Command Deceleration Time	UINT	RW	No	ms
0x2303	-	Speed Command S-curve Time	UINT	RW	No	ms

## 8.2 Programmed Jog Operation

A programmed jog operation is a function that verifies the servo motor operation by speed control at the preset operation speed and time without an upper level controller.

Before starting the jog operation, make sure of the following:

- The main power is turned on;
- the STO (Safety Torque Off) connector is connected;
- no alarms go off;
- the servo is turned off;
- the speed and time settings are set with consideration to the state and operation range of the apparatus.

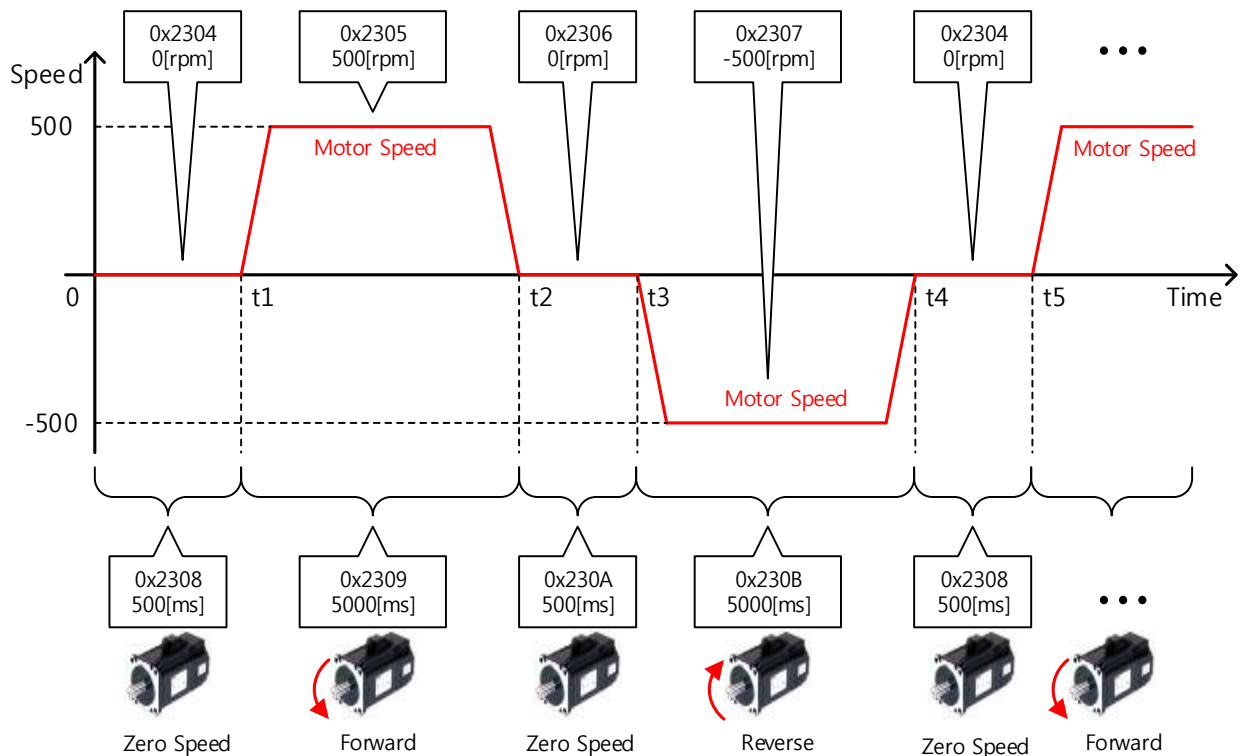

### ■ Related Objects

Index	Sub Index	Name	Variable type	Accessibility	PDO Assignment	Unit
0x2304	-	Program Jog Operation Speed 1	INT	RW	No	rpm
0x2305	-	Program Jog Operation Speed 2	INT	RW	No	rpm
0x2306	-	Program Jog Operation Speed 3	INT	RW	No	rpm
0x2307	-	Program Jog Operation Speed 4	INT	RW	No	rpm
0x2308	-	Program Jog Operation Time 1	UINT	RW	No	ms
0x2309	-	Program Jog Operation Time 2	UINT	RW	No	ms
0x230A	-	Program Jog Operation Time 3	UINT	RW	No	ms
0x230B	-	Program Jog Operation Time 4	UINT	RW	No	ms

## 8.3 Deleting Alarm History

This function deletes all of the alarm code history stored in the drive. Alarm history items are stored chronologically starting with the latest alarm up to 16 recent alarms.

You can check them below (0x2702:01 - 16). The newest alarm is listed in 0x2702:01.

2702:0	Servo Alarm History	RO	> 16 <
2702:01	Alarm code 1(Newest)	RO	[51]POS following
2702:02	Alarm code 2	RO	[51]POS following
2702:03	Alarm code 3	RO	[51]POS following
2702:04	Alarm code 4	RO	[51]POS following
2702:05	Alarm code 5	RO	[51]POS following
2702:06	Alarm code 6	RO	[51]POS following
2702:07	Alarm code 7	RO	[51]POS following
2702:08	Alarm code 8	RO	[51]POS following
2702:09	Alarm code 9	RO	[51]POS following
2702:0A	Alarm code 10	RO	[51]POS following
2702:0B	Alarm code 11	RO	[51]POS following
2702:0C	Alarm code 12	RO	[51]POS following
2702:0D	Alarm code 13	RO	[51]POS following
2702:0E	Alarm code 14	RO	[51]POS following
2702:0F	Alarm code 15	RO	[51]POS following
2702:10	Alarm code 16(Oldest)	RO	[51]POS following

### ■ Related Objects

Index	Sub Index	Name	Variable type	Accessibility	PDO Assignment	Unit
0x2702	-	Servo Alarm History	-	-	-	-
	1	Alarm code 1(Newest)	STRING	RO	No	-
	2	Alarm code 2	STRING	RO	No	-



3	Alarm code 3	STRING	RO	No	-
4	Alarm code 4	STRING	RO	No	-
5	Alarm code 5	STRING	RO	No	-
6	Alarm code 6	STRING	RO	No	-
7	Alarm code 7	STRING	RO	No	-
8	Alarm code 8	STRING	RO	No	-
9	Alarm code 9	STRING	RO	No	-
10	Alarm code 10	STRING	RO	No	-
11	Alarm code 11	STRING	RO	No	-
12	Alarm code 12	STRING	RO	No	-
13	Alarm code 13	STRING	RO	No	-
14	Alarm code 14	STRING	RO	No	-
15	Alarm code 15	STRING	RO	No	-
16	Alarm code 16(Oldest)	STRING	RO	No	-

## 8.4 Auto Gain Tuning

For more information, please refer to 7.1 Offline Auto Gain Tuning and 7.2 Online Auto Gain Tuning.

## 8.5 Index Pulse Search

The index pulse search function is used to find the index (Z) pulse position of the encoder and stop it. You can use this function to roughly locate the position since it searches for the position using the speed operation mode. You can locate the exact position of the index pulse using the homing operation.

The speed to use to search for the index pulse is set in 0x230C (rpm).

Before starting the index pulse search, make sure of the following:

- The main power is turned on;
- no alarms go off;

- the servo is turned off;
- the Safety Torque Off (STO) connector is installed; and
- the operation speed is set with consideration to the operation range of the machine.

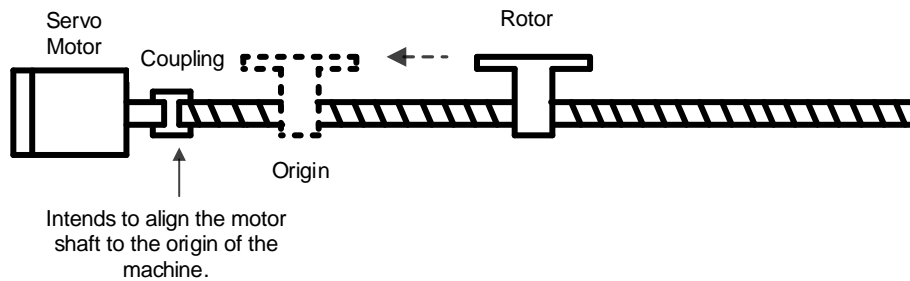

■ Related Objects

Index	Sub Index	Name	Variable type	Accessibility	PDO Assignment	Unit
0x230C	-	Index Pulse Search Speed	INT	RW	No	rpm

## 8.6 Absolute Encoder Reset

This function resets the absolute encoder. You need to reset the absolute encoder in the following cases:

- When you set up the apparatus for the first time
- When you replace the battery after an encoder low voltage alarm has occurred
- When you want to set the multi-turn data of the absolute encoder to 0

When you turn off the power and then it on again after resetting the absolute value encoder, the multi-rotation data (0x260A) is reset to 0.

■ Related Objects

Index	Sub Index	Name	Variable type	Accessibility	PDO Assignment	Unit
0x2005	-	Absolute Encoder Configuration	UINT	RW	No	-
0x260A		MultiTurn Data	DINT	RO	Yes	rev

## 8.7 Instantaneous Maximum Torque Initialization

This function initializes the instantaneous maximum overload rate (0x2604) to 0. The instantaneous maximum operation overload rate represents the maximum value of the operation overload rate output instantaneously from the drive.

It displays the maximum (peak) load, between the current time and the time when the servo is turned on, as a percentage of the rated output. The unit is 0.1%. Power cycling will reset it to 0.

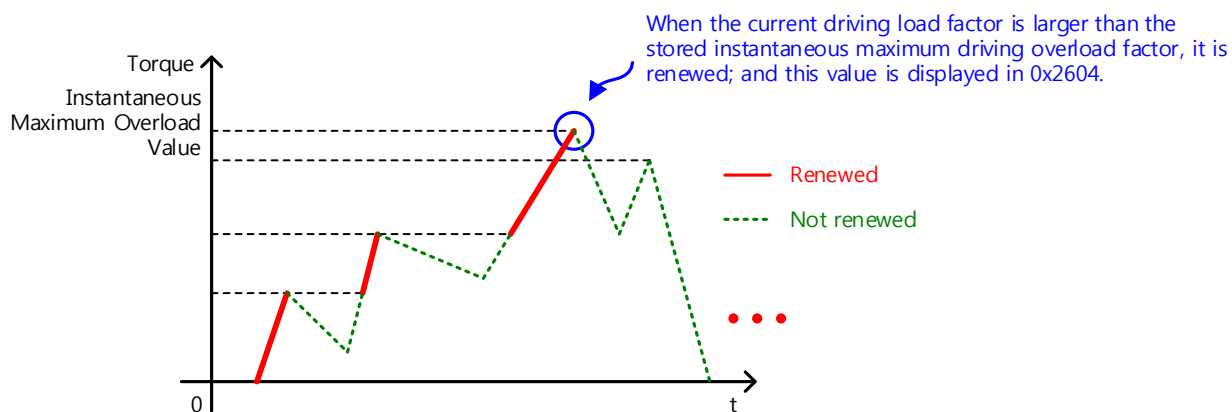

### ■ Related Objects

Index	Sub Index	Name	Variable type	Accessibility	PDO Assignment	Unit
0x2604	-	Instantaneous Maximum Operation Overload	INT	RO	Yes	0.1%

## 8.8 Phase Current Offset Tuning

This function is to automatically tune the current offset of the U, V, W phases. Depending on the environmental conditions, you can tune the phase current offset for use. The offset is tuned by the factory default settings.

Measured U-/V-/W-phase offsets are individually stored in 0x2015, 0x2016, and 0x2017. If an offset is too large, an AL-15 will be generated.

### ■ Related Objects

Index	Sub Index	Name	Variable type	Accessibility	PDO Assignment	Unit
-------	-----------	------	---------------	---------------	----------------	------

0x2015	-	U Phase Current Offset	INT	RW	No	0.1%
0x2016	-	V Phase Current Offset	INT	RW	No	0.1%
0x2017	-	W Phase Current Offset	INT	RW	No	0.1%

## 8.9 Software Reset

This function resets the servo drive using software. Software reset means restarting the drive program, resulting in an effect similar to power cycling.

You can use this function in the following cases:

- When changing the parameter settings that require power cycling
- When you have to restart the drive due to an alarm that cannot be reset

## 8.10 Commutation

The commutation function gets information about the initial angle of the motor. When using a motor that is not equipped with a hall sensor, you have to get information about the initial angle through commutation prior to operation, in order to carry out normal operations.

### ■ Related Objects

Index	Sub Index	Name	Variable type	Accessibility	PDO Assignment	Unit
0x2019	-	Linear Scale Resolution	UINT	RW	No	nm
0x201A	-	Commutation Method	UINT	RW	No	-
0x201B	-	Commutation Current	UINT	RW	No	0.1%
0x201C	-	Commutation Time	UINT	RW	No	ms

# 9. Full-Closed Control

The full-closed control function is used to read the position feedback signals from a linear encoder and various encoders on the load side. You can configure the desired system and carry out precision position control without being affected by mechanical system errors. Basically, the full-closed control system uses the external position sensor on the load side to carry out position control. The motor-side encoder is used for speed control. A dual feedback control system, which combines the full-closed control and semi-closed control, can provide a faster response by using the position data of the high-speed rotating motor encoder and the load-side external encoder.

## 9.1 Full-Closed Control Internal Configuration

The internal configuration of full-closed control is shown below.

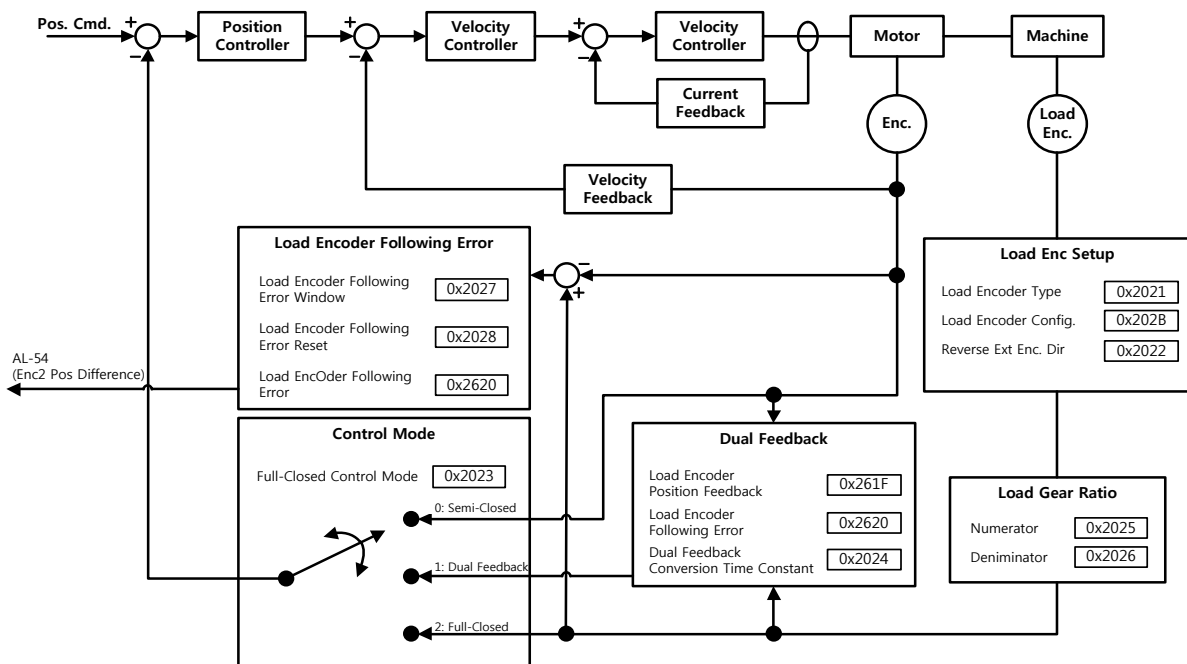

Function	Details	
Semi-Closed Control	It carries out position control based on the encoder information from the motor.	
	Advantages	Since it is rarely affected by the vibrations of the machine, you can raise the servo gain to shorten the adjustment time.
	Disadvantages	The machine's accuracy can be lowered due to the vibrations of the machine even when the motor is not running.

Full-Closed Control	It carries out position control based on information from the position sensor that is separately mounted on the machine.	
	Advantages	The machine's accuracy can be controlled regardless of whether the motor is running or is stationary.
	Disadvantages	Since it is easily affected by the vibrations of the machine, it cannot raise the servo gain too much and the adjustment time may take longer.
Dual-Feedback Control	It carries out position control using the position sensor information from either the motor or the machine. It has advantages when the sampling rate is low in the external encoder.	
	Advantages	It operates based on the position information from the motor while the motor is running and from the machine while the motor is stationary to raise the gain and shorten the adjustment time. It can stop the motor with the accuracy of the machine to improve control performance.
	Disadvantages	

## 9.2 Full-Closed Control Parameter Settings

You can set the full-closed control parameters in the following order.

1. Setting the full-closed control mode

0x2023	Full-Closed Control Mode						ALL
Variable type	Setting range	Initial value	Unit	Accessibility	PDO assignment	Change attribute	Retentive
UINT	0 to 2	0	-	RW	No	Power cycling	Yes

This sets the full-closed control mode.

Settings	Setting details
0	Semi-Closed Control (controls using only the motor-side encoder, default value)
1	Full-Closed Control (controls using the load-side position sensor)
2	Dual-Feedback Control (controls using the motor-side encoder and load-side

	position sensor)
--	------------------

2. Setting the load encoder-type

0x2021	Load Encoder Type						ALL
Variable type	Setting range	Initial value	Unit	Accessi- bility	PDO assignment	Change attribute	Rete- ntive
UINT	0 to 1	0	-	RW	No	Power cycling	Yes

This sets the second encoder type on the load side.

Settings	Setting details
0	Incremental encoder: Pulse-type incremental encoder
1	SSI encoder: Serial communication-type incremental encoder

3. Entering load encoder information

0x202B	Load Encoder Configuration						ALL
Variable type	Setting range	Initial value	Unit	Accessi- bility	PDO assignment	Change attribute	Rete- ntive
UINT	0 to 65535	13	-	RW	No	Power cycling	Yes

This sets the second encoder, which is attached to the load side.

The setting method is the same as the motor-side encoder setting [0x202A].

4. Setting the load encoder direction

0x2022	Reverse Load Encoder Direction						ALL
Variable type	Setting range	Initial value	Unit	Accessi- bility	PDO assignment	Change attribute	Rete- ntive
UINT	0 to 1	0	-	RW	No	Power	Yes

						cycling	
--	--	--	--	--	--	---------	--

This sets the rotation direction based on the installation direction of the load-side encoder.

Settings	Setting details
0	Forward (CCW)
1	Reverse (CW)

5. Motor encoder - setting the load encoder scale

0x2025	Numerator of External Encoder Scale						ALL
Variable type	Setting range	Initial value	Unit	Accessi- bility	PDO assignment	Change attribute	Rete- ntive
UINT	0 to 2147483647	0	-	RW	No	Power cycling	Yes

0x2026	Denominator of External Encoder Scale						ALL
Variable type	Setting range	Initial value	Unit	Accessi- bility	PDO assignment	Change attribute	Rete- ntive
UINT	0 to 2147483647	0	-	RW	No	Power cycling	Yes

This sets the numerator/denominator scale for the external encoder to ensure the same scale as the motor encoder,

Examples of scale setting methods

1. Direct connection structure	This sets the scale so the number of external encoder pulses can be calculated based on the number of encoder pulses per motor rotation.
Motor encoder specifications	524288[pulse/rev]
Amount of load movement/revolution	12000[pulse/rev]

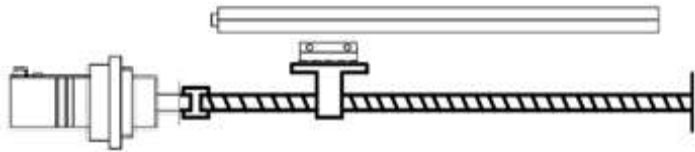

<p>Gear ratio setting</p>	<p>Number of external encoder pulses x (numerator / denominator) = Number of motor encoder pulses</p> $12000(\text{Number of external encoder pulses}) \times \frac{524288 (\text{Numerator})}{12000 (\text{Denominator})} = 524288(\text{Number of motor encoder pulses})$
---------------------------	---

<p>2. Gearbox structure</p>	 <ul style="list-style-type: none"> <li>- Reduction gear ratio: 1/10</li> <li>- Ball screw lead: 20 mm</li> <li>- Linear encoder (external encoder): 4 um</li> </ul> <p>If the 1/10-ratio gearbox is installed on the motor, the gearbox shaft rotates 1/10 turns per motor rotation. So, the scale is calculated by multiplying the deceleration ratio with the number of external encoder pulses.</p>
-----------------------------	---

<p>Motor encoder specifications</p>	<p>524288[pulse/rev]</p>
-------------------------------------	--------------------------

<p>Amount of load movement/revolution</p>	<p>The movement of the table per rotation of the servo motor equipped with a 1/10 gearbox is</p> <p><math>(1/10) * 20 \text{ mm} = 2 \text{ mm}</math>. The number of external encoder pulses is calculated as <math>2 \text{ mm} / 4 \text{ um} = 500 \text{ pulses}</math>.</p>
---	---

<p>Gear ratio setting</p>	<p>Number of external encoder pulses x (numerator / denominator) = Number of motor encoder pulses</p> $500(\text{Number of external encoder pulses}) \times \frac{524288 (\text{Numerator})}{500 (\text{Denominator})} = 524288(\text{Number of motor encoder pulses})$
---------------------------	---

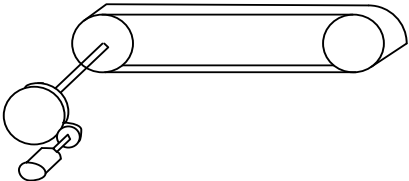
<p>3. Belt-pulley structure</p>	 <ul style="list-style-type: none"> <li>- Motor-side pulley diameter: 30 mm</li> <li>- Rotary-side pulley diameter: 20 mm</li> <li>- External encoder resolution: 20000 pulse/rev</li> </ul> <p>In the case of a gear and belt-pulley system, the final gear ratio is calculated</p>
---------------------------------	---

	and the gear ratio is multiplied by the number of external encoder pulses to produce the scale.
Motor encoder specifications	524288[pulse/rev]
Amount of load movement/revolution	The external encoder rotates at a ratio of 30 / 20 per servo motor rotation. The number of pulses for the external encoder is calculated as 20000 x (3/2) = 30000 pulses.
Gear ratio setting	<p>Number of external encoder pulses x (numerator / denominator) = Number of motor encoder pulses</p> $30000(\text{Number of external encoder pulses}) \times \frac{524288 (\text{Numerator})}{30000 (\text{Denominator})} = 524288(\text{Number of motor encoder pulses})$

6. Setting the load encoder position error level and initialization

0x2027	External Encoder Following Error Window						ALL
Variable type	Setting range	Initial value	Unit	Accessibility	PDO assignment	Change attribute	Retentive
UDINT	0 to 2147483647	100000	pulse	RW	No	Power cycling	Yes

0x2028	External Encoder Following Error Reset						ALL
Variable type	Setting range	Initial value	Unit	Accessibility	PDO assignment	Change attribute	Retentive
UDINT	0 to 10000	10	Revolution	RW	No	Power cycling	Yes

This sets the position error level for the external encoder and the reset range for the error position value.

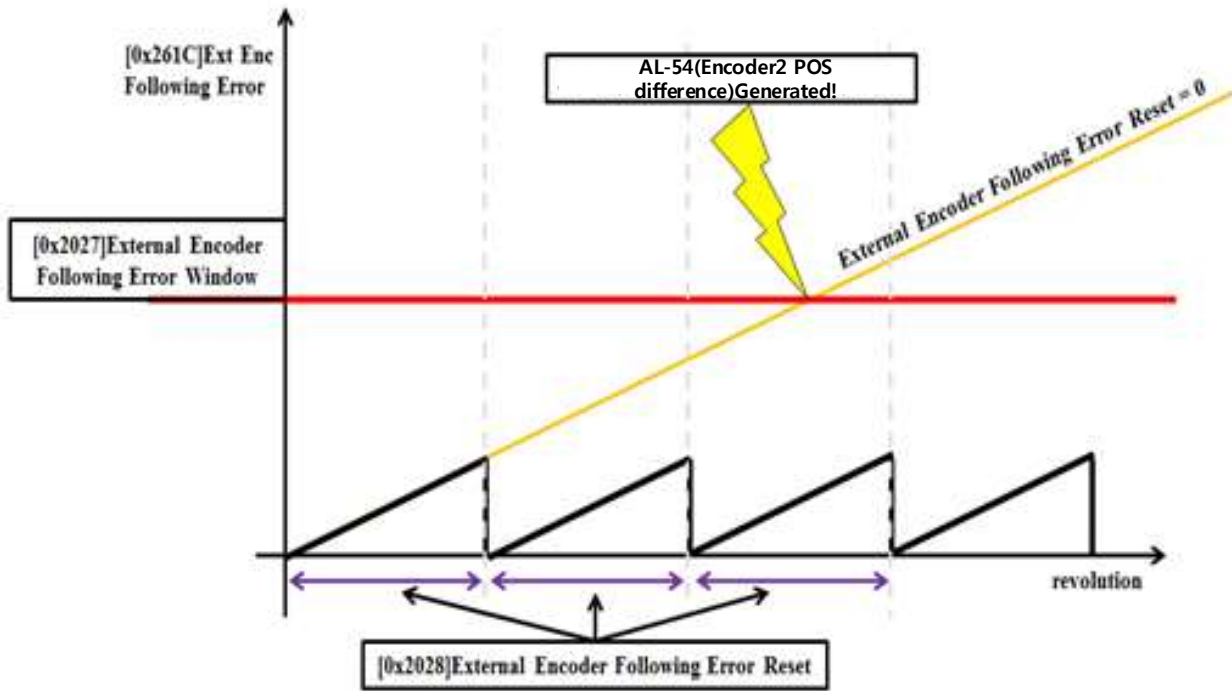

Based on the 0x2027 (External Encoder Following Error Window) settings, the AL-54 (Encoder2 POS difference) level can be adjusted.

For a system where a slip occurs, the 0x2028 (External Encoder Following Error Reset) settings can be used to set the normal slip range for the following error value.

7. Setting the dual-feedback filter time constant

0x2029	Dual Feedback Conversion Time Constant						ALL
Variable type	Setting range	Initial value	Unit	Accessability	PDO assignment	Change attribute	Retentive
UINT	0 to 1000	0	0.1ms	RW	No	Always	Yes

In the case of dual-feedback control that refers to an external encoder, the filter time constant is set to 0.1 ms at the time when the mode switches between semi-closed control and full-closed control.

As the setting gets close to 0 ms, it refers to the external encoder more. As it gets close to 100 ms, it refers to the motor-side encoder more. It minimizes the vibrations that are generated due to mechanical characteristics or external factors to shorten the adjustment time.

Examples of setting the dual-feedback filter time constant

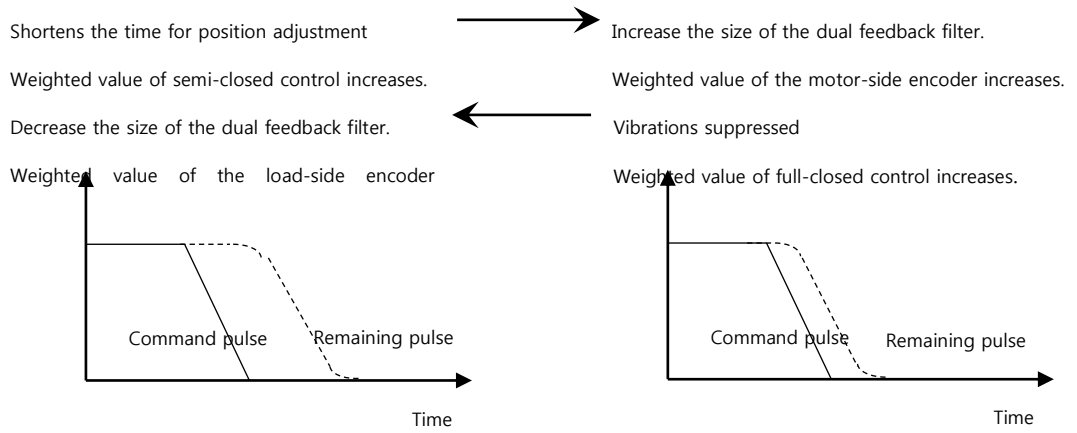

# 10. Indexing Operation

## 10.1 Control Type

The Phoenix series drive not only supports the operation mode via 0x6060, but also supports a separate control mode via 0x3000. The control mode can be accessed with the EOE method. It supports the index position operation mode, which generates the position command from inside; pulse input position operation mode, which receives a pulse train from outside; speed operation mode, which controls speed based on external analog voltage and internal parameters; and torque operation mode, which controls torque with an external analog voltage, to determine the position.

## 10.2 Indexing Position Operation

The indexing position mode creates a position profile inside the drive without using an external, upper-level controller to reach the target position. If you wish to use the index function, set the control mode (0x3000) to "index mode".

The block diagram of indexing position mode is as follows:

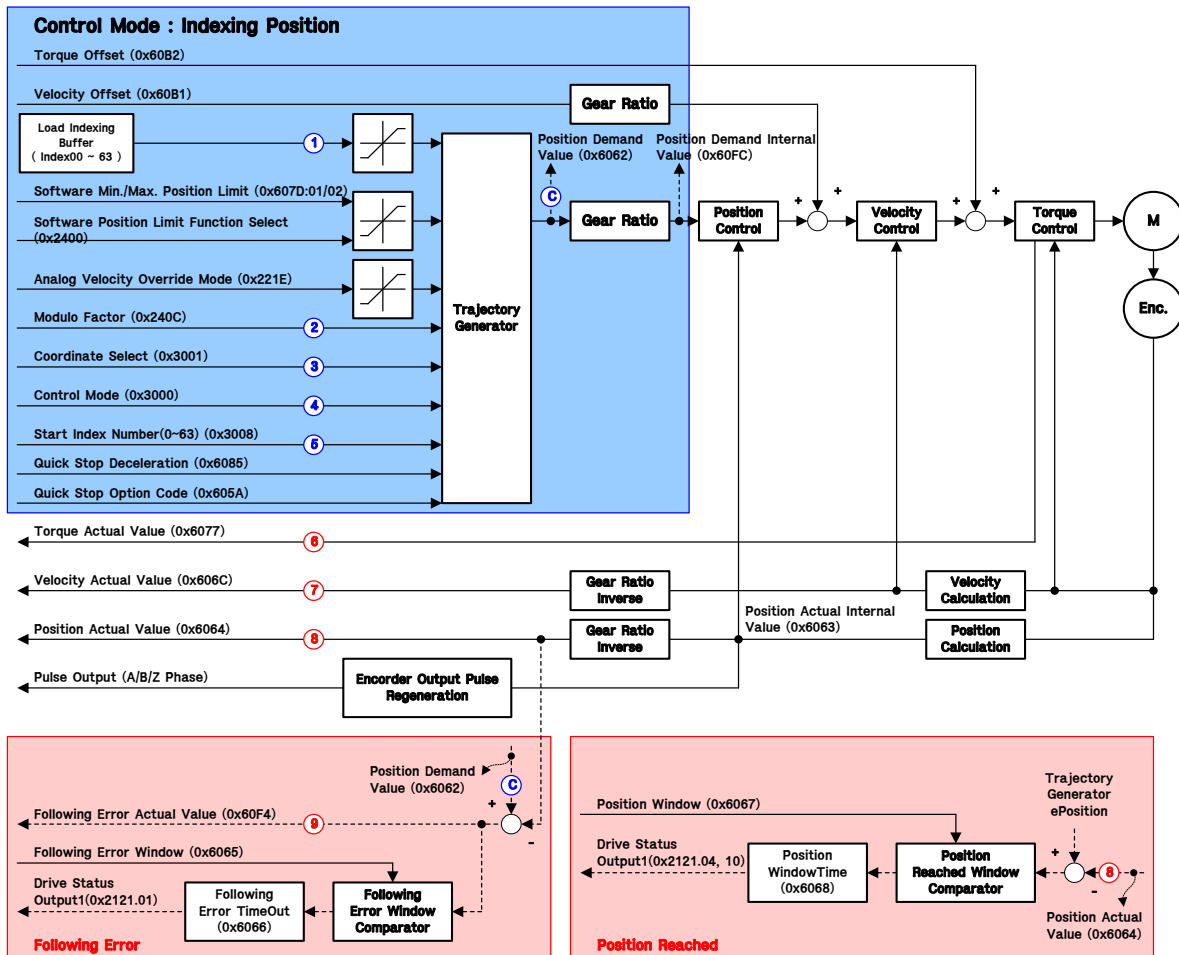

## ■ Related Objects

Index	Sub Index	Name	Variable type	Accessibility	PDO Assignment	Unit
0x2121	-	Drive Status Output1	UINT	RO	Yes	-
0x2122	-	Drive Status Output2	UINT	RO	Yes	-
0x6062	-	Position Demand Value	DINT	RO	Yes	UU
0x60FC	-	Position Demand Internal Value	DINT	RO	Yes	pulse
0x6063	-	Position Actual Internal Value	DINT	RO	Yes	pulse
0x6064	-	Position Actual Value	DINT	RO	Yes	UU
0x607D	-	Software Position Limit	-	-	-	-
	0	Number of entries	USINT	RO	No	-
	1	Min position limit	DINT	RW	No	UU
	2	Max position limit	DINT	RW	No	UU
0x6085	-	Quick Stop Deceleration	UDINT	RW	No	UU/s <sup>2</sup>
0x605A	-	Quick Stop Option Code	INT	RW	No	-
0x60B1	-	Velocity Offset	DINT	RW	Yes	UU/s
0x60B2	-	Torque Offset	INT	RW	Yes	0.1%
0x606C	-	Velocity Actual Value	DINT	RO	Yes	UU/s
0x6077	-	Torque Actual Value	INT	RO	Yes	0.1%
0x6065	-	Following Error Window	UDINT	RW	No	UU
0x6066	-	Following Error Timeout	UINT	RW	No	ms
0x6067	-	Position Window	UDINT	RW	No	UU
0x6068	-	Position Window Time	UINT	RW	No	ms
0x6091	-	Gear Ratio	-	-	-	-
	0	Number of entries	USINT	RO	No	-
	1	Motor Revolutions	UDINT	RW	No	-
	2	Shaft Revolutions	UDINT	RW	No	-
0x240C	-	Modulo Factor	DINT	RW	No	UU
0x3000	-	Control Mode	UINT	RW	No	-
0x3001	-	Coordinate Select	UINT	RW	No	-
0x3002	-	Baud Rate Select	UINT	RW	No	-

0x3006	-	Encoder Output Pulse	UDINT	RW	No	Pulse
0x3007	-	Encoder Output Mode	UINT	RW	No	
0x3008	-	Start Index Number(0~63)	UINT	RW	No	-
0x3009	-	Index Buffer Mode	UINT	RW	No	-
0x300A	-	IOUT Configuration	UINT	RW	No	-
0x3100	-	Index 00	-	-	-	-
	0	Number of entries	USINT	RO	No	-
	1	Index Type	UINT	RW	No	-
	2	Distance	DINT	RW	No	UU
	3	Velocity	DINT	RW	No	UU/s
	4	Acceleration	DINT	RW	No	UU/s <sup>2</sup>
	5	Deceleration	DINT	RW	No	UU/s <sup>2</sup>
	6	Registration Distance	DINT	RW	No	UU
	7	Registration Velocity	DINT	RW	No	UU/s
	8	Repeat Count	UINT	RW	No	-
	9	Dwell Time	UINT	RW	No	ms
	10	Next Index	UINT	RW	No	-
11	Action	UINT	RW	No	-	
~		~				
0x313F	-	Index 63	-	-	-	-
0x222B	-	Analog Input Function Select	UINT	RW	No	-
0x221C	-	Analog Torque Input(command/limit) Scale	UINT	RW	No	0.1%/V
0x221D	-	Analog Torque Input(command/limit) Offset	INT	RW	No	mV
0x221F	-	Analog Velocity Input(command/Override) Offset	INT	RW	No	mV

### Internal Block Diagram of Indexing Position Mode

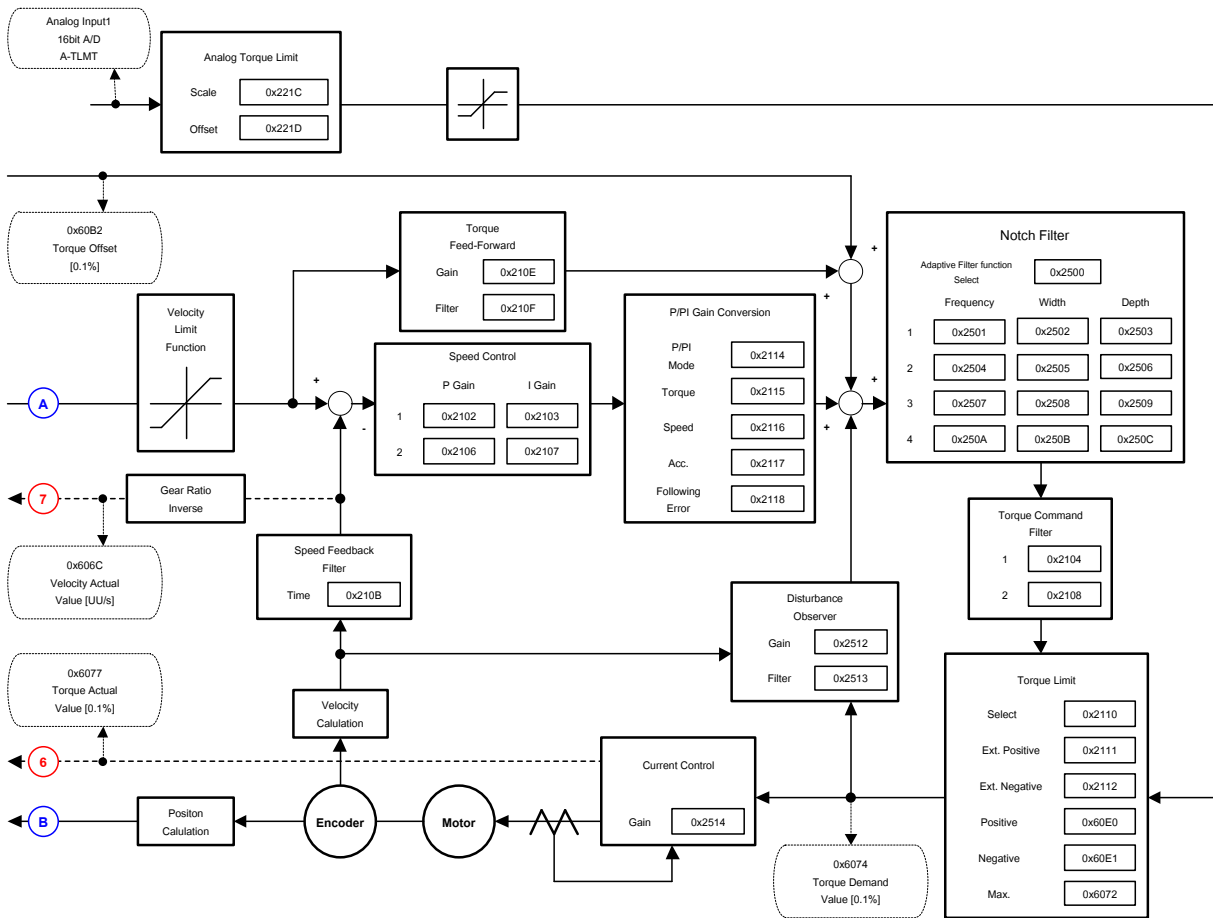



## 10.2.1 Setting the Coordinates

For indexing mode, two coordinates types can be used as shown below.

### ■ Linear Coordinate Type

Linear coordinates display position values in the range of -2147483648 to +2147483647. If it rotates clockwise and exceeds +2147483647, the minimum value -2147483648 is displayed. If it rotates counterclockwise and exceeds -2147483648, the maximum value +2147483647 is displayed.

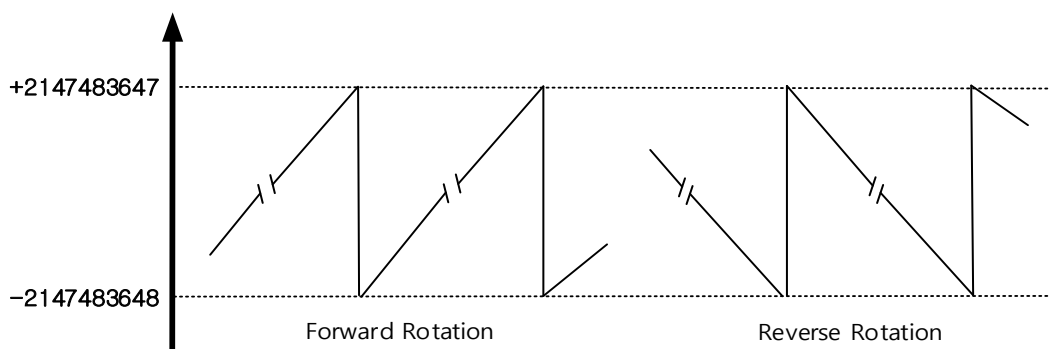

For the 6 PTP position controls below, the control mode (0x3000) should be set to linear coordinates.

- Absolute Move

For absolute movement, the final moving distance is calculated by subtracting the target distance from the current position.

- Relative Move

For relative movement, the final moving distance is the target distance.

- Registration Absolute Move

When the REGT signal is received from the outside while moving to the target position, it switches to the registered speed and distance and moves to the new target position (absolute value).

- Registration Relative Move

When the REGT signal is received from the outside while moving to the target position, it switches to the registered speed and distance and moves to the new target position (relative value).

- Blending Absolute Move

After receiving a new position command while driving to the target position, it subsequently drives to the new target position (absolute value) after driving to the existing target position.

- Blending Relative Move

After receiving a new position command while driving to the target position, it subsequently drives to the new target position (relative value) after driving to the existing target position.

## ■ Rotary Coordinate Type

Rotary coordinates only display a positive position value. The display range changes depending on the modulo factor settings. The position value is displayed in the range of 0 to Modulo Factor-1.

If it rotates clockwise and exceeds the value of Modulo Factor-1, the minimum value 0 is displayed. If it rotates counterclockwise and exceeds the value of 0, the maximum value Modulo Factor-1 is displayed.

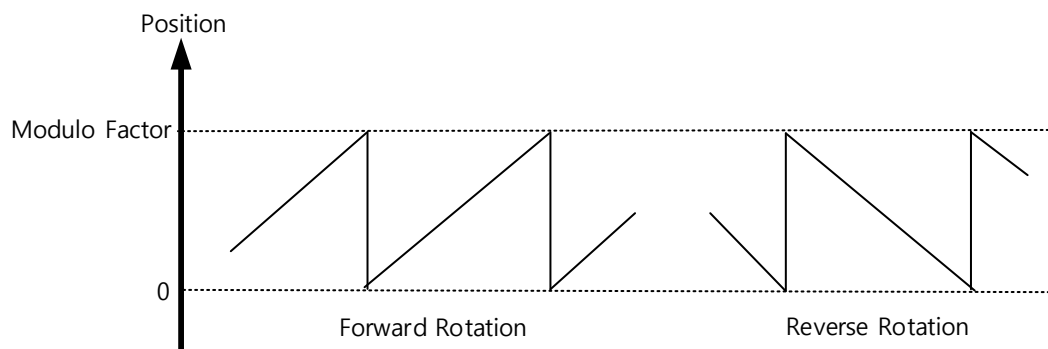

For the 5 PTP position controls below, the control mode (0x3000) should be set to rotary coordinates. In this case, the modulo factor should be set correctly.

- Rotary Absolute Move

The operating direction is determined based on the relationship between current position and the Distance value to perform the position operation. It does not necessarily follow the shortest path. Depending on the Distance value, it can only rotate within one cycle (the value set in modulo factor).

- Rotary Relative Move

If Distance is a positive (+) value, the position operation is performed in the positive direction. If Distance is a negative (-) value, the position operation is performed in the negative direction. Depending on the Distance value, it can rotate more than one cycle (the value set in modulo factor).

- Rotary Shortest Move

The operating direction is determined based on the shortest distance from the current position to perform the position operation. Depending on the Distance value, it can only rotate within one cycle (the value set in modulo factor). Distance is processed as absolute value.

- Rotary Positive Move

The position operation is always conducted in the positive (+) direction. Depending on the Distance value, it can only rotate within one cycle (the value set in modulo factor). Distance is processed as absolute value.

- Rotary Negative Move

The position operation is always conducted in the (-) direction. Depending on the Distance value, it can only rotate within one cycle (the value set in modulo factor). Distance is processed as absolute value.

## 10.2.2 Index Structure

The index structure is as follows:

Item		Description
Index Type	Linear Coordinate	0 : Absolute Move
		1 : Relative Move
		2 : Registration Absolute Move
		3 : Registration Relative Move
		4 : Blending Absolute Move
	5 : Blending Relative Move	
	Rotary Coordinate	6 : Rotary Absolute Move
		7 : Rotary Relative Move
		8 : Rotary Shortest Move
		9 : Rotary Positive Move
10 : Rotary Negative Move		
Distance	-2147483648 to +2147483647 (unit: UU*)	
Velocity	1 to 2147483647 (unit: UU/s)	
Acceleration	1 to 2147483647 (unit: UU/s <sup>2</sup> )	
Deceleration	1 to 2147483647 (unit: UU/s <sup>2</sup> )	
Registration Distance	-2147483648 to 2147483647 (unit: UU)	
Registration Velocity	1 to 2147483647 (unit: UU/s)	
Repeat Count	1 ~ 65535	
Dwell Time	0 to 65535 (unit: ms)	
Next Index	0 ~ 63	
Action	0 : Stop 1 : Wait for Start 2 : Next Index	

\*UU: User Unit

## 10.3 Pulse Input Position Operation

The servo drive provides the mode that determines the position using the pulse train input from an external controller. If you wish to use the pulse input type position control mode, the control mode (0x3000) should be set to "pulse input-type position control mode".

The block diagram of pulse input position mode is as follows:

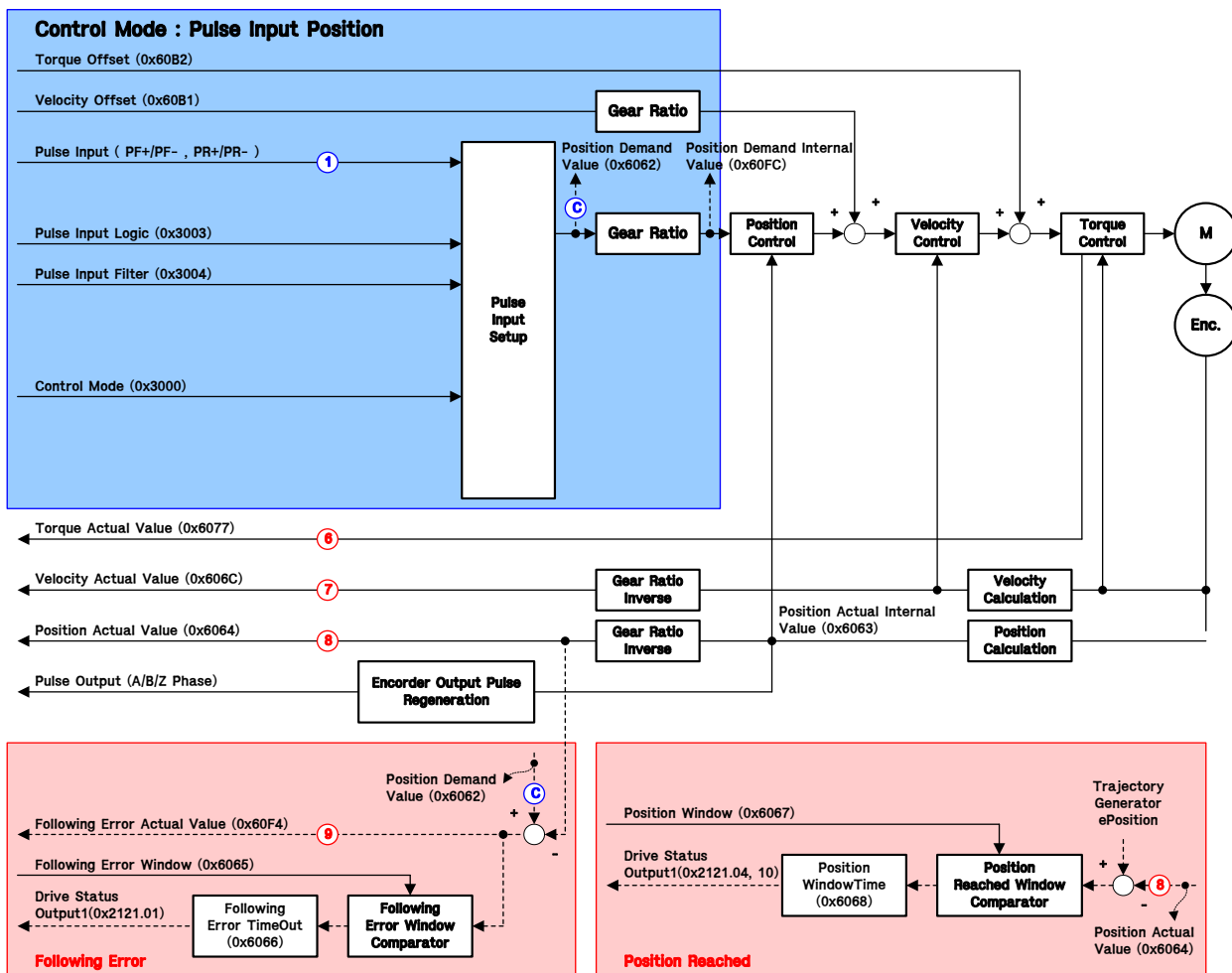

■ Related Objects

Index	Sub Index	Name	Variable type	Accessibility	PDO Assignment	Unit
0x2121	-	Drive Status Output1	UINT	RO	Yes	-
0x2122	-	Drive Status Output2	UINT	RO	Yes	-
0x6062	-	Position Demand Value	DINT	RO	Yes	UU
0x60FC	-	Position Demand Internal Value	DINT	RO	Yes	pulse
0x6063	-	Position Actual Internal Value	DINT	RO	Yes	pulse
0x6064	-	Position Actual Value	DINT	RO	Yes	UU
0x60B1	-	Velocity Offset	DINT	RW	Yes	UU/s
0x60B2	-	Torque Offset	INT	RW	Yes	0.1%
0x606C	-	Velocity Actual Value	DINT	RO	Yes	UU/s
0x6077	-	Torque Actual Value	INT	RO	Yes	0.1%
0x6065	-	Following Error Window	UDINT	RW	No	UU
0x6066	-	Following Error Timeout	UINT	RW	No	ms
0x6067	-	Position Window	UDINT	RW	No	UU
0x6068	-	Position Window Time	UINT	RW	No	ms
0x6091	-	Gear Ratio	-	-	-	-
	0	Number of entries	USINT	RO	No	-
	1	Motor Revolutions	UDINT	RW	No	-
	2	Shaft Revolutions	UDINT	RW	No	-
0x240C	-	Modulo Factor	DINT	RW	No	UU
0x3000	-	Control Mode	UINT	RW	No	-
0x3001	-	Coordinate Select	UINT	RW	No	-
0x3002	-	Baud Rate Select	UINT	RW	No	-
0x3003	-	Pulse Input Logic Select	UINT	RW	No	-
0x3004	-	Pulse Input Filter Select	UINT	RW	No	-
0x3005	-	PCLEAR Mode Select	UINT	RW	No	-
0x3006	-	Encoder Output Pulse	UDINT	RW	No	Pulse
0x3007	-	Encoder Output Mode	UINT	RW	No	
0x222B	-	Analog Input Function Select	UINT	RW	No	

0x221C	-	Analog Torque Input(command/limit) Scale	UINT	RW	No	0.1%/V
0x221D	-	Analog Torque Input(command/limit) Offset	INT	RW	No	mV

### Internal Block Diagram of Pulse Input Position Mode

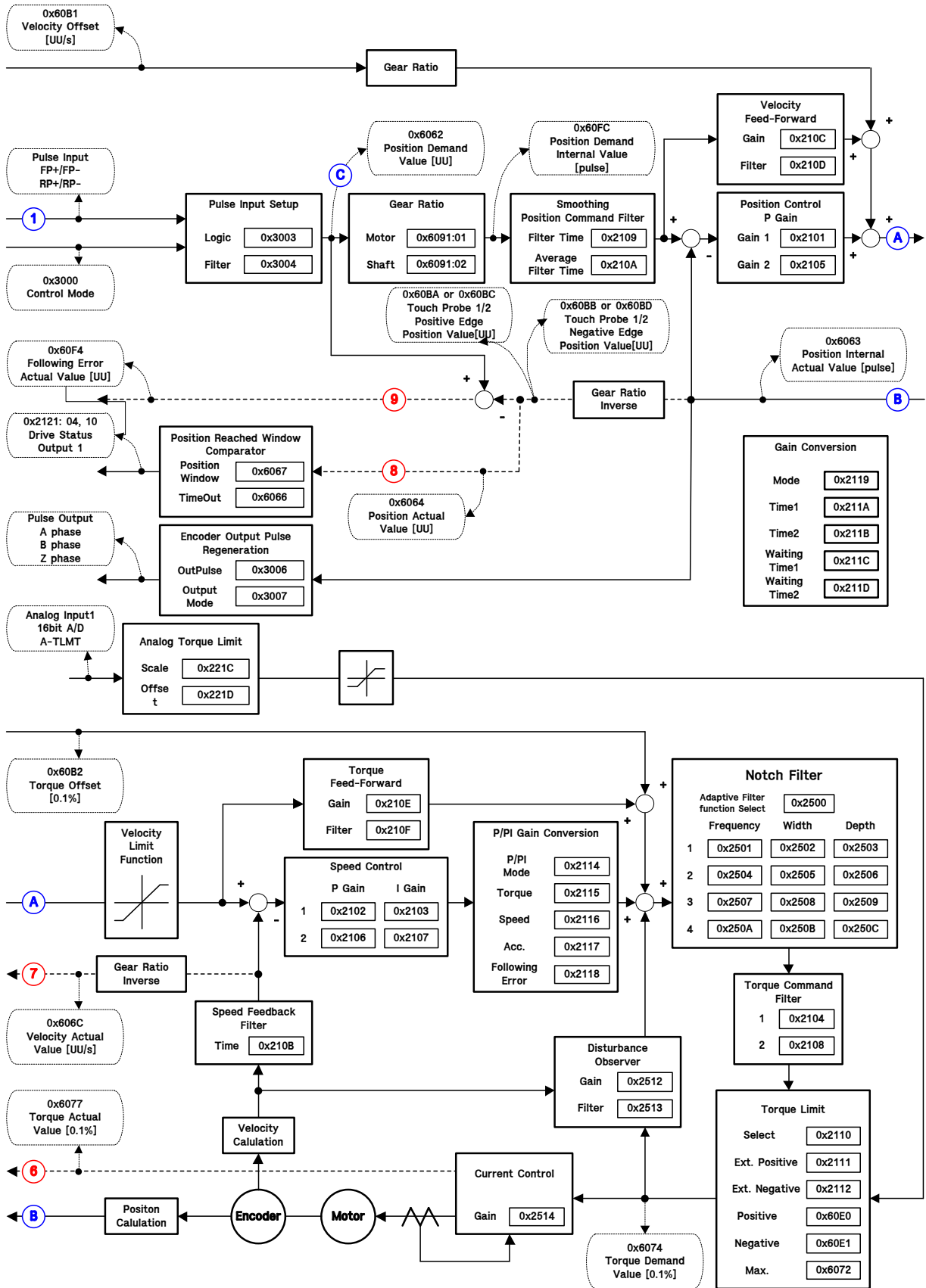

# 10.4 Speed Operation

The speed operation mode is used to control the speed by applying a digital input-type speed command to the servo drive using the parameter settings inside the servo drive and by applying an analog voltage-type speed command received from an upper-level controller to the servo drive.

Set the control mode [0x3000] to 2 and select the speed command switch [0x231A] depending on the method with which you want to command the servo drive.

The block diagram of the speed operation mode is shown below.

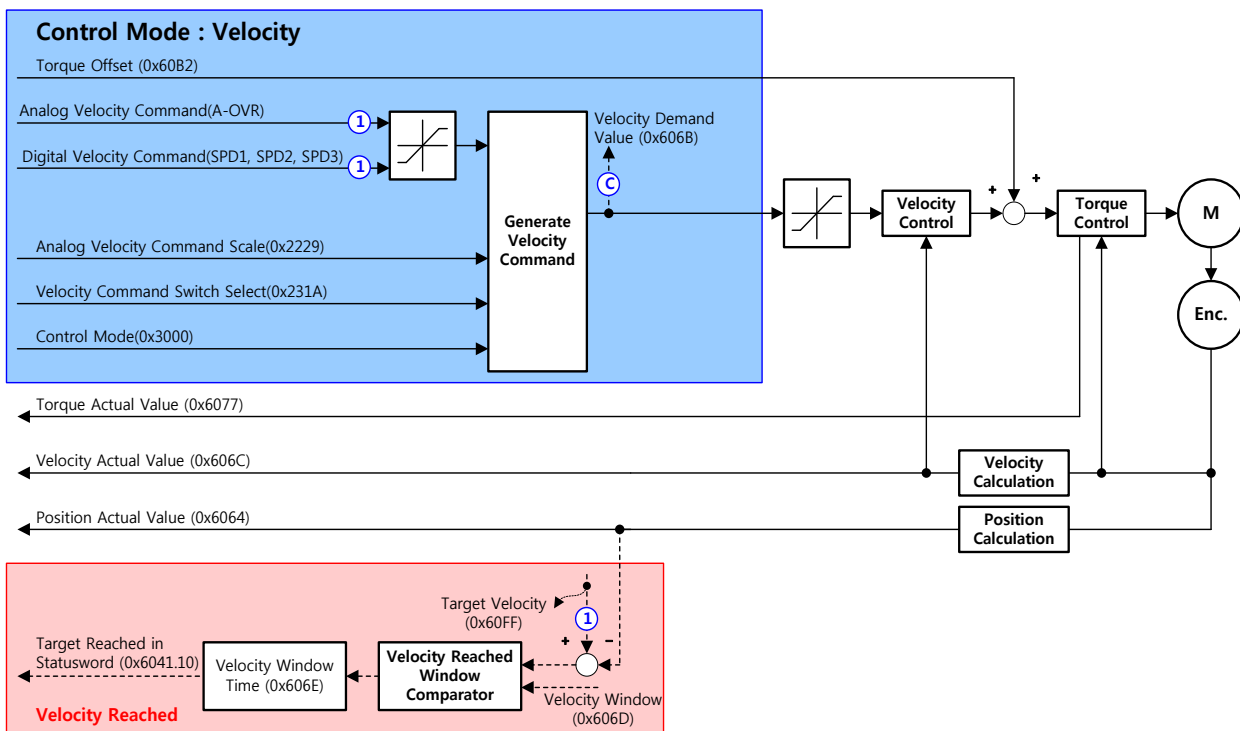



## ■ Related Objects

Index	Sub Index	Name	Variable type	Accessibility	PDO Assignment	Unit
0x2121	-	Drive Status Output1	UINT	RO	Yes	-
0x2122	-	Drive Status Output2	UINT	RO	Yes	-
0x6062	-	Position Demand Value	DINT	RO	Yes	UU
0x60FC	-	Position Demand Internal Value	DINT	RO	Yes	pulse
0x6063	-	Position Actual Internal Value	DINT	RO	Yes	pulse
0x6064	-	Position Actual Value	DINT	RO	Yes	UU
0x60B1	-	Velocity Offset	DINT	RW	Yes	UU/s
0x60B2	-	Torque Offset	INT	RW	Yes	0.1%
0x606C	-	Velocity Actual Value	DINT	RO	Yes	UU/s
0x6077	-	Torque Actual Value	INT	RO	Yes	0.1%
0x6065	-	Following Error Window	UDINT	RW	No	UU
0x6066	-	Following Error Timeout	UINT	RW	No	ms
0x6067	-	Position Window	UDINT	RW	No	UU
0x6068	-	Position Window Time	UINT	RW	No	ms
0x3000	-	Control Mode	UINT	RW	No	-
0x3002	-	Baud Rate Select	UINT	RW	No	-
0x3006	-	Encoder Output Pulse	UDINT	RW	No	Pulse
0x3007	-	Encoder Output Mode	UINT	RW	No	
0x2200	-	Digital Input Signal 1 Selection	UINT	RW	No	-
0x2201	-	Digital Input Signal 2 Selection	UINT	RW	No	-
0x2202	-	Digital Input Signal 3 Selection	UINT	RW	No	-
0x2203	-	Digital Input Signal 4 Selection	UINT	RW	No	-
0x2204	-	Digital Input Signal 5 Selection	UINT	RW	No	-
0x2205	-	Digital Input Signal 6 Selection	UINT	RW	No	-
0x2206	-	Digital Input Signal 7 Selection	UINT	RW	No	-
0x2207	-	Digital Input Signal 8 Selection	UINT	RW	No	-
0x2208	-	Digital Input Signal 9 Selection	UINT	RW	No	-
0x2209	-	Digital Input Signal 10 Selection	UINT	RW	No	-

0x220A	-	Digital Input Signal 11 Selection	UINT	RW	No	-
0x220B	-	Digital Input Signal 12 Selection	UINT	RW	No	-
0x220C	-	Digital Input Signal 13 Selection	UINT	RW	No	-
0x220D	-	Digital Input Signal 14 Selection	UINT	RW	No	-
0x220E	-	Digital Input Signal 15 Selection	UINT	RW	No	-
0x220F	-	Digital Input Signal 16 Selection	UINT	RW	No	-
0x222B	-	Analog Input Function Select	UINT	RW	No	
0x221C	-	Analog Torque Input(command/limit) Scale	UINT	RW	No	0.1%/V
0x221D	-	Analog Torque Input(command/limit) Offset	INT	RW	No	mV
0x221F	-	Analog Velocity Input(command/Override) Offset	INT	RW	No	mV
0x2227	-	Analog Velocity Command Filter Time Constant	UINT	RW	No	-
0x2229	-	Analog Velocity Command Scale	INT	RW	No	-
0x222A	-	Analog Velocity Command Clamp Level	UINT	RW	No	-
0x2312	-	Multi-Step Operation Speed 1	INT	RW	No	-
0x2313	-	Multi-Step Operation Speed 2	INT	RW	No	-
0x2314	-	Multi-Step Operation Speed 3	INT	RW	No	-
0x2315	-	Multi-Step Operation Speed 4	INT	RW	No	-
0x2316	-	Multi-Step Operation Speed 5	INT	RW	No	-
0x2317	-	Multi-Step Operation Speed 6	INT	RW	No	-
0x2318	-	Multi-Step Operation Speed 7	INT	RW	No	-
0x2319	-	Multi-Step Operation Speed 8	INT	RW	No	-
0x231A	-	Velocity Command Switch Select	UINT	RW	No	-
0x2227	-	Analog Velocity Command Filter Time Constant	UINT	RW	No	-

### Internal Block Diagram of Speed Operation Mode

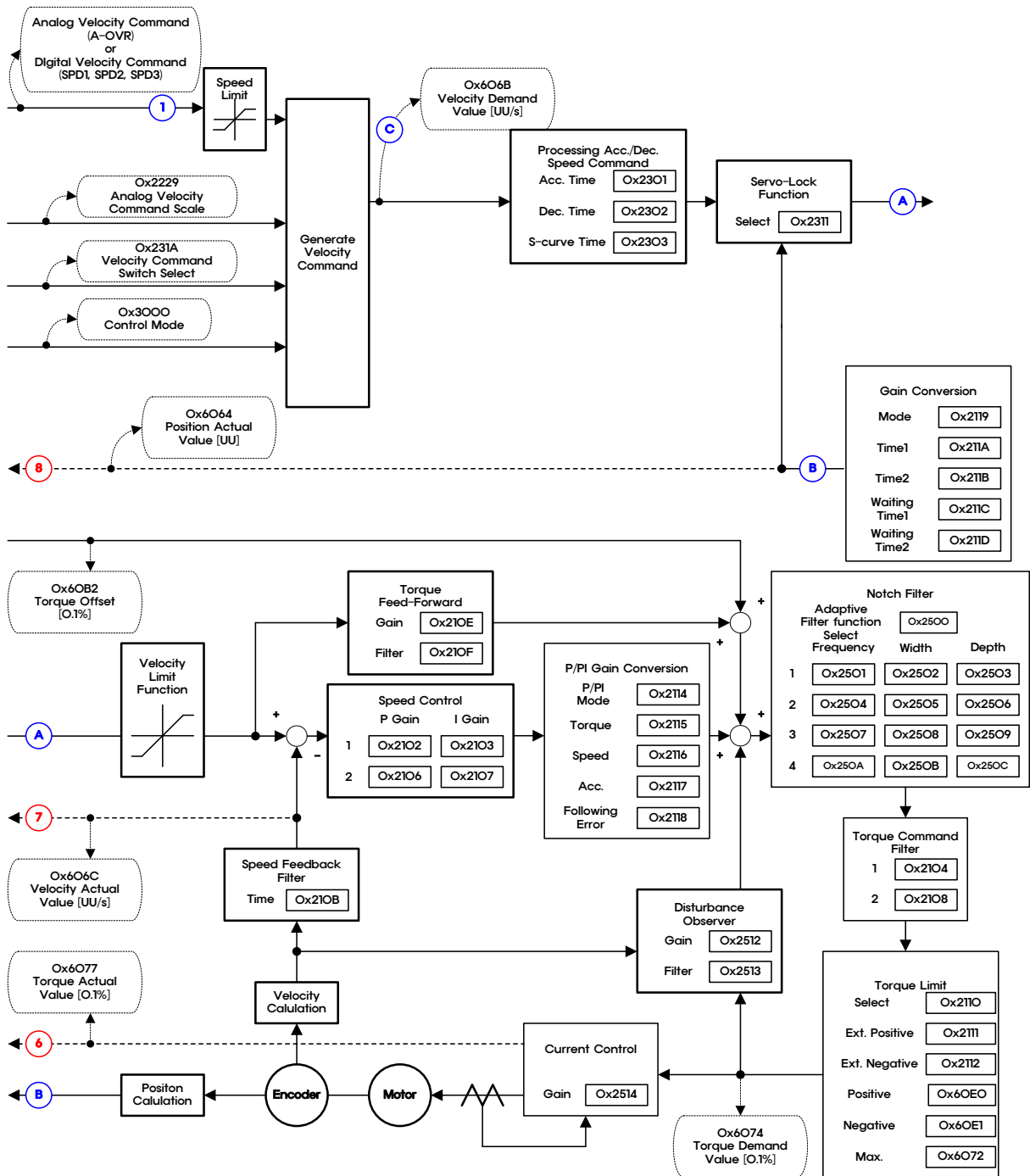

## 10.5 Torque Operation

In torque operation mode, the servo drive receives the voltage that corresponds to the desired torque from an upper-level controller to control tension or pressure on the machine.

Please set control mode [0x3000] to 3.

In order to input the command, apply -10 V to +10 V voltage to the No. 7 and 8 pins of the I/O connector.

The block diagram of the torque operation mode is shown below.

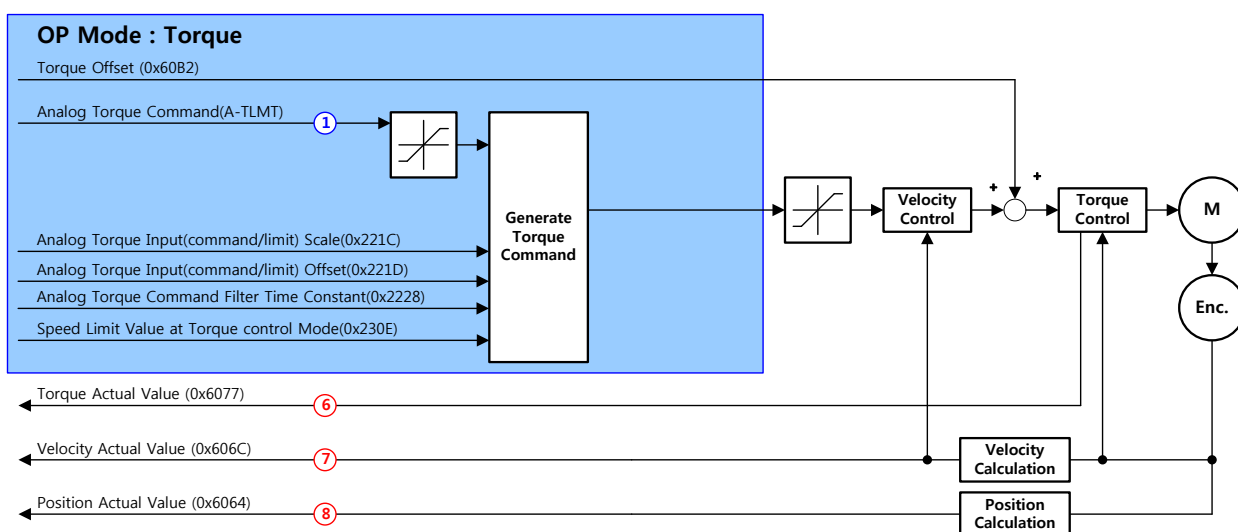

### ■ Related Objects

Index	Sub Index	Name	Variable type	Accessibility	PDO Assignment	Unit
0x2121	-	Drive Status Output1	UINT	RO	Yes	-
0x2122	-	Drive Status Output2	UINT	RO	Yes	-
0x6062	-	Position Demand Value	DINT	RO	Yes	UU
0x60FC	-	Position Demand Internal Value	DINT	RO	Yes	pulse
0x6063	-	Position Actual Internal Value	DINT	RO	Yes	pulse
0x6064	-	Position Actual Value	DINT	RO	Yes	UU
0x60B1	-	Velocity Offset	DINT	RW	Yes	UU/s
0x60B2	-	Torque Offset	INT	RW	Yes	0.1%
0x606C	-	Velocity Actual Value	DINT	RO	Yes	UU/s
0x6077	-	Torque Actual Value	INT	RO	Yes	0.1%

0x6065	-	Following Error Window	UDINT	RW	No	UU
0x6066	-	Following Error Timeout	UINT	RW	No	ms
0x6067	-	Position Window	UDINT	RW	No	UU
0x6068	-	Position Window Time	UINT	RW	No	ms
0x3000	-	Control Mode	UINT	RW	No	-
0x3002	-	Baud Rate Slect	UINT	RW	No	-
0x3006	-	Encoder Output Pulse	UDINT	RW	No	Pulse
0x3007	-	Encoder Output Mode	UINT	RW	No	-
0x222B	-	Analog Input Function Select	UINT	RW	No	
0x221C	-	Analog Trque Input(command/limit) Scale	UINT	RW	No	-
0x221D	-	Analog Trque Input(command/limit) Offset	INT	RW	No	-
0x2228	-	Analog Trque Command Filter Time Constant	UINT	RW	No	-
0x230E	-	Speed Limit Value at Torque Control Mode	UINT	RW	No	-

### ■ Internal Block Diagram of Torque Operation Mode

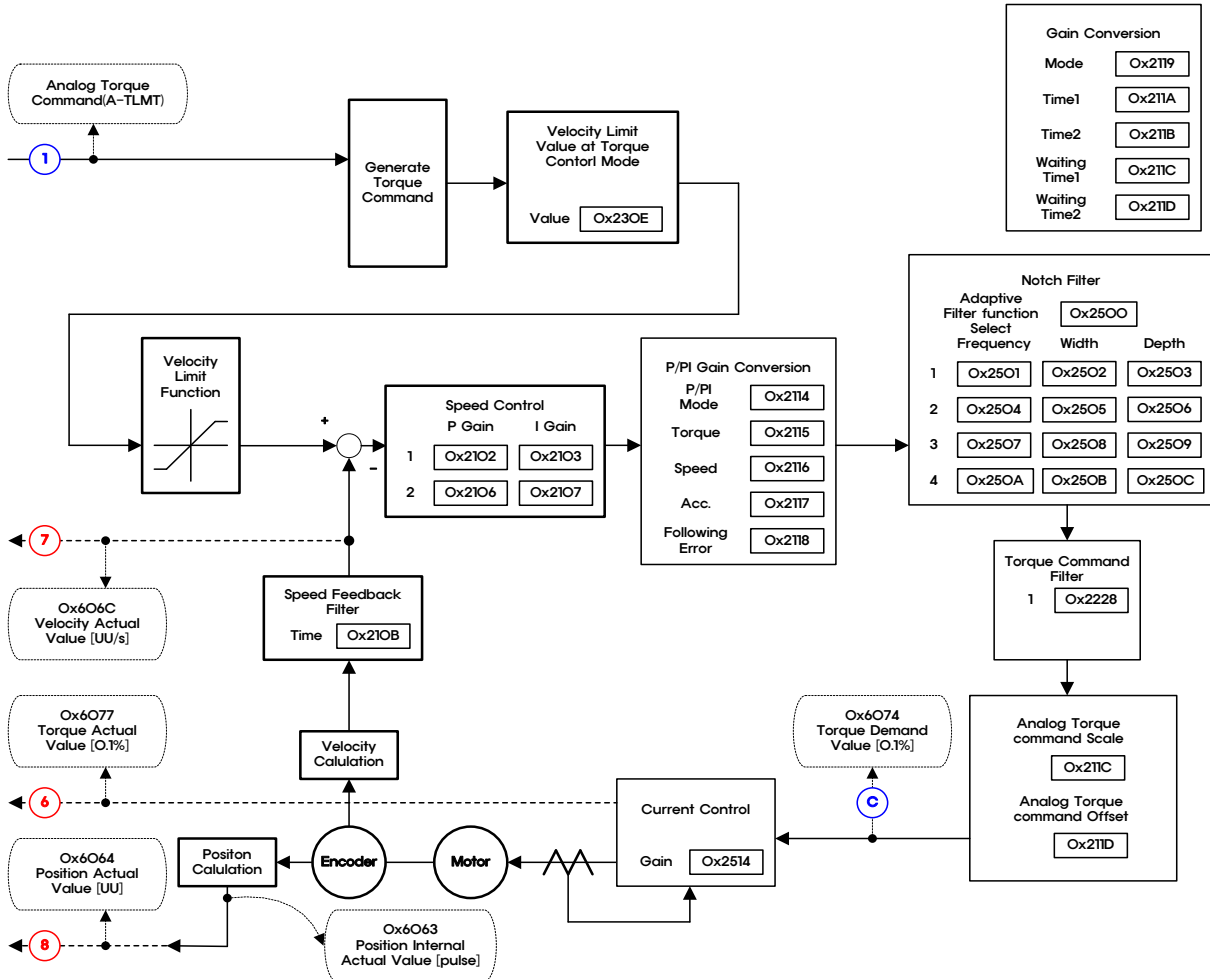

## 10.6 Indexing Position Operation

### 10.6.1 Index Concept

An index is composed of the distance, velocity, acceleration, deceleration, registration distance, registration velocity, repeat count, dwell time, next index, and action as shown below. For details on each element, refer to the information below.

#### ■ Distance

This is the moving distance of each index (unit: UU). You can set an absolute moving distance or relative moving distance.

The final moving distance for absolute movement is calculated by subtracting Distance from the current position. The final moving distance for relative movement is Distance.

For the speed/acceleration patterns shown below, the final moving distance is the area.

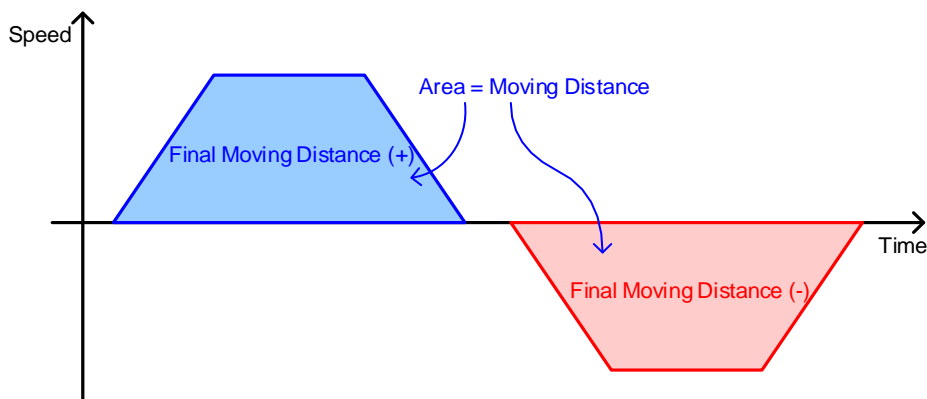

### ■ Velocity

Sets the target speed for index operation (unit: UU/s).

Velocity is set with positive (+) values only regardless of the moving distance. The sign of the target speed depends on whether Distance is positive or negative.

If the moving distance is not sufficient compared to the speed and acceleration/deceleration settings, a triangular pattern may appear where the target speed is not reached.

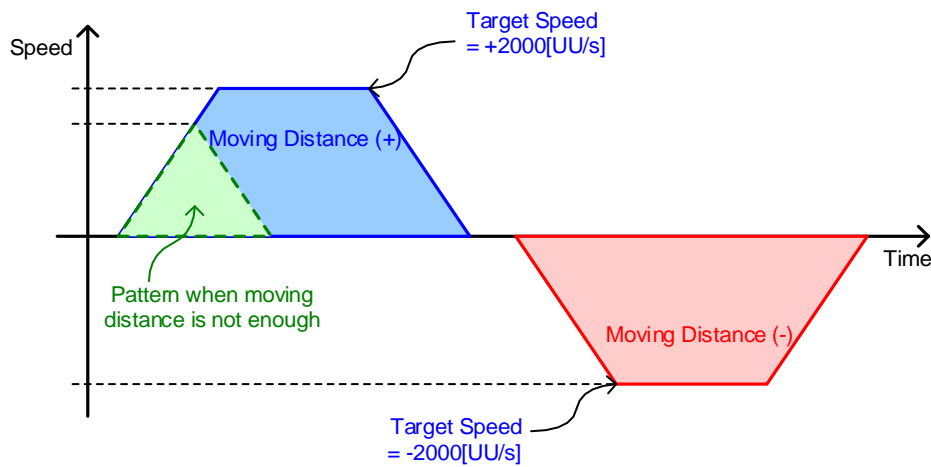

### ■ Acceleration and Deceleration

Set the acceleration and deceleration for the index operation. It supports asymmetric acceleration/deceleration operation where acceleration and deceleration are set differently.

If velocity =  $1000\text{ UU/s}$ , acceleration =  $10000\text{ UU/s}^2$ , deceleration =  $20000\text{ UU/s}^2$  as indicated below, the acceleration time for reaching the target speed is  $100\text{ ms}$  ( $=1000\text{ UU/s} / 10000\text{ UU/s}^2$ ) and the deceleration time is  $50\text{ ms}$  ( $=1000\text{ UU/s} / 20000\text{ UU/s}^2$ ).

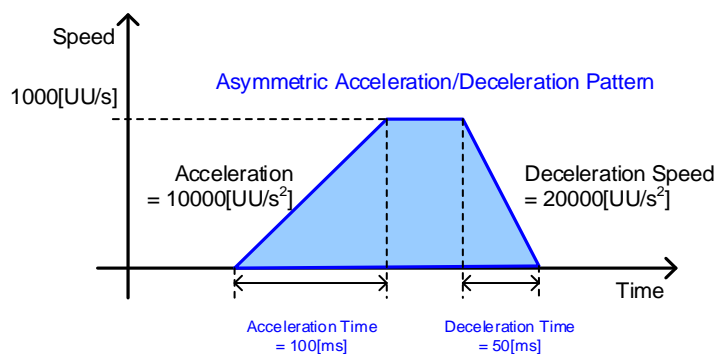



## ■ Registration Distance and Registration Velocity

If the index type is registration absolute or registration relative, you can change the operation speed and moving distance with a REGT signal received from outside.

The moving distance after the REGT signal is received is determined by the registration distance.

The meaning of registration distance and registration velocity are defined below.

- Registration Distance
  - This is the moving distance after the REGT signal is received from outside (unit: UU).
- Registration Velocity
  - This is the target speed after the REGT signal is received from outside (unit: UU/s).

When speed changes during registration, the acceleration/deceleration is the same as the original acceleration/deceleration.

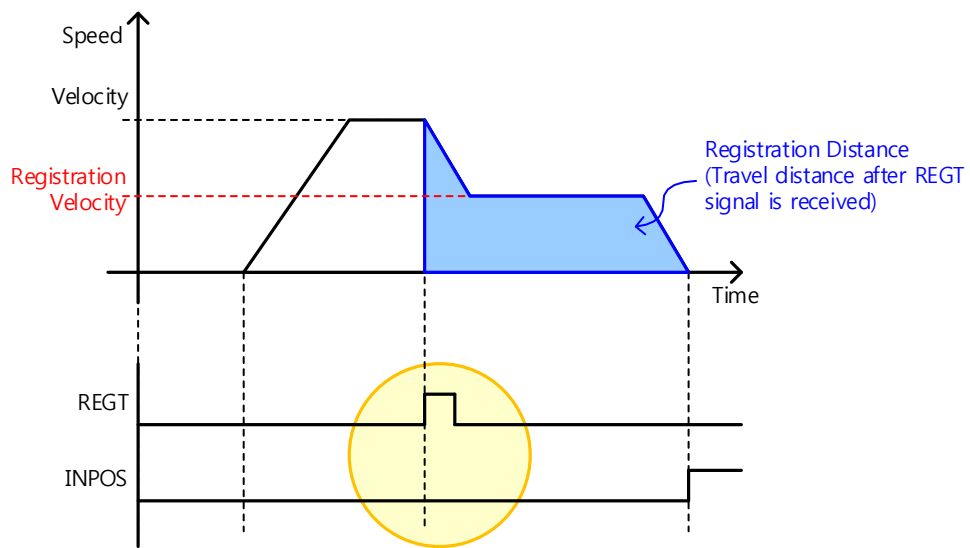

### ■ Repeat Count

The index repeats the operation based on the value set for the repeat count.

In the case of an index repeat operation, the value set for the dwell time does not apply.

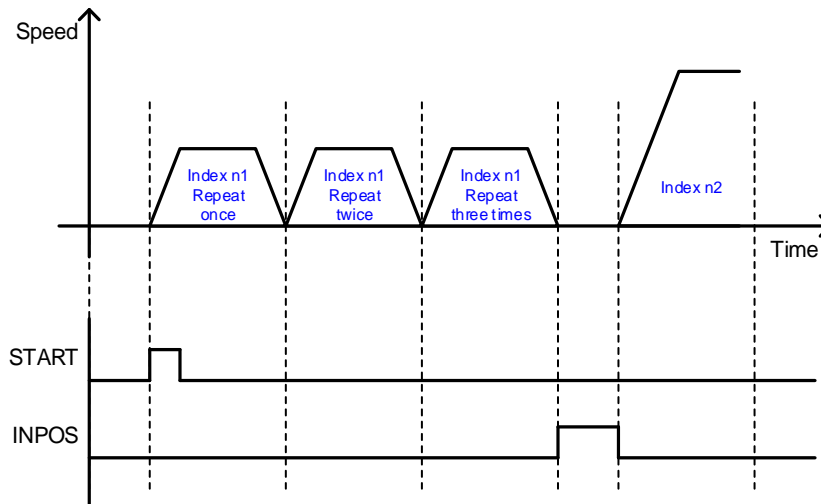

### ■ Dwell Time

This sets the dwell time between index operations (unit: ms).

Dwell time is applied after the operation pattern of the corresponding index has been generated as shown below.

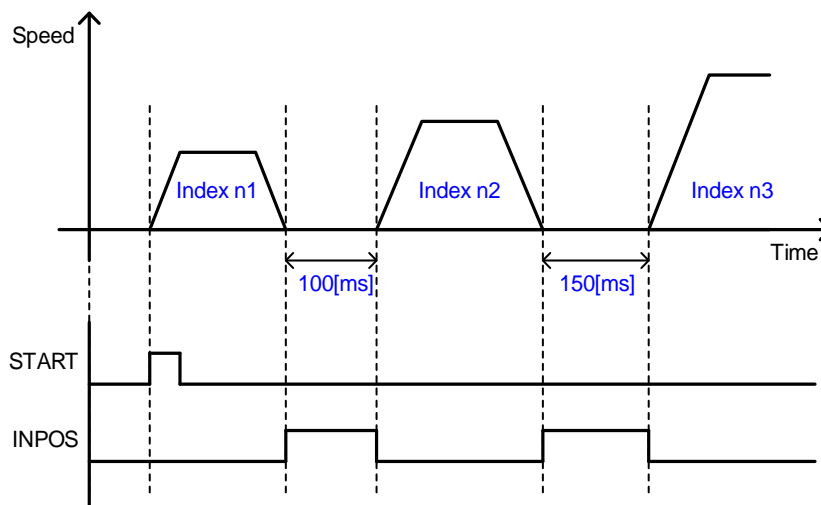

### ■ Next Index

If the index action is set to Next Index (setting 2), it sets the number for the next index that will be automatically executed after the current index has finished.

For more information, please refer to the explanation about the next index in the Action section below.

### ■ Action

For indexing position mode, the following three kinds of actions can be used depending on the index action.

- STOP

If the index action is set to Stop (setting 0), the entire sequence is terminated after the current index has finished.

If a Start signal is received from outside, an indexing position operation starts from the index (0 - 63) set in Start Index (0x3008).

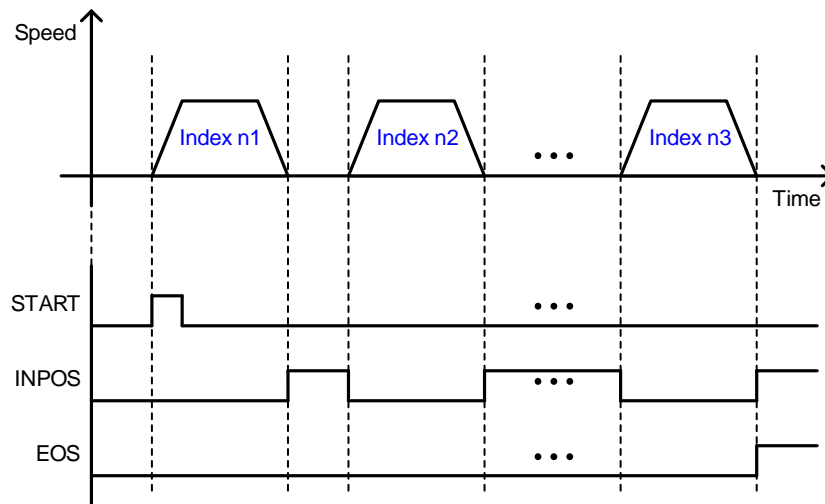

- Wait for Start

If the index action is set to Wait for Start (setting 1), Next Index is executed according to the Start signal input after the current index has finished.

The index that is executed after the Start signal is determined by the ISEL 0 - 5 (Index Select) signal. In this case, the index is irrelevant to the value set in Next Index.

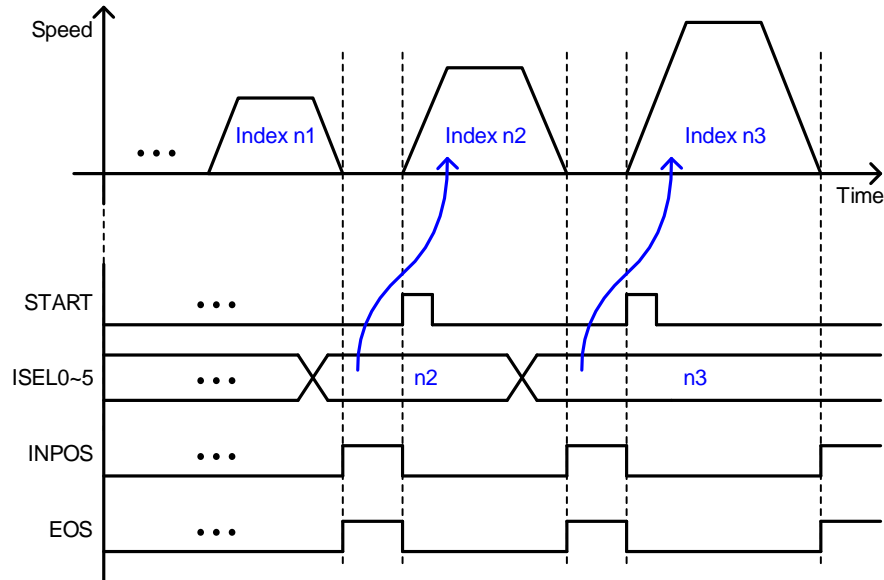

- Next Index

If the action for the index is set to Next Index (setting 2), the index that is set as Next Index is executed after the current index has finished.

Even if you do not enter a digital input signal (Start, ISEL 0 - 5), it can automatically operate with the index that was entered in advance.

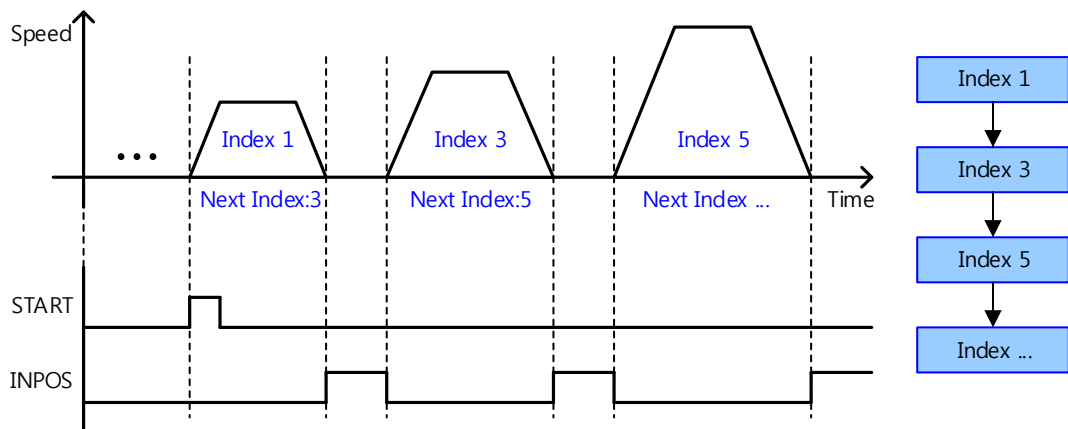

- Examples of action settings

If you combine Wait for Start and Next Index, you can configure a bifurcated sequence as shown below.

In this case, you should set the Index 3 action to Wait for Start.

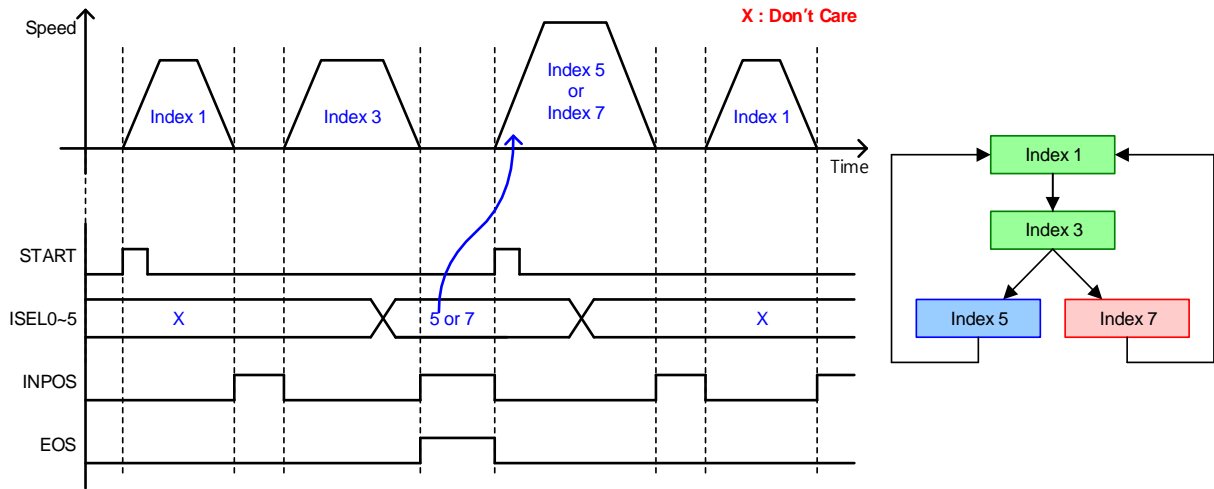

## 10.6.2 Index Type

The L7P drive supports a total of 11 index types for the indexing position mode as shown below.

### 10.6.2.1 Absolute / Relative Move

These are the most basic PTP (Point-to-Point) operation types that move to absolute or relative positions based on speed and acceleration.

#### ■ Absolute Move

The final moving distance is calculated by subtracting the current position from the Distance input value. (= Distance - Current Position)

E.g. Performing absolute move with Distance = 1000 when the current position value is 500

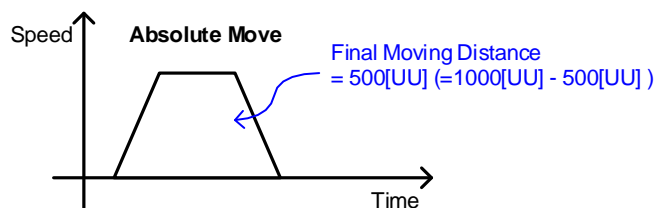

#### ■ Relative Move

The final moving distance is the Distance input value.

E.g. Performing relative move with Distance = 1000 when the current position value is 500

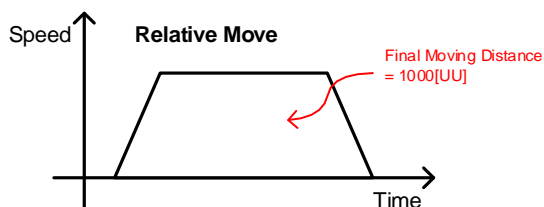

## 10.6.2.2 Registration Absolute / Relative Move

You can change the operation speed and moving distance with the REGT signal.

This function is similar to the motion pattern creation in the previous model, the VP-3 (position operation after feeder and sensor).

### ■ Registration Absolute Move

This carries out the absolute movement with the value set in Distance. When the REGT signal is received while moving, it moves with the position and speed set in Registration Distance/Velocity. The moving distance after the REGT signal is received is set in Registration Distance.

### ■ Registration Relative Move

This carries out the relative movement with the value set in Distance. When the REGT signal is received while moving, it moves with the position and speed set in Registration Distance/Velocity. The moving distance after the REGT signal is received is set in Registration Distance.

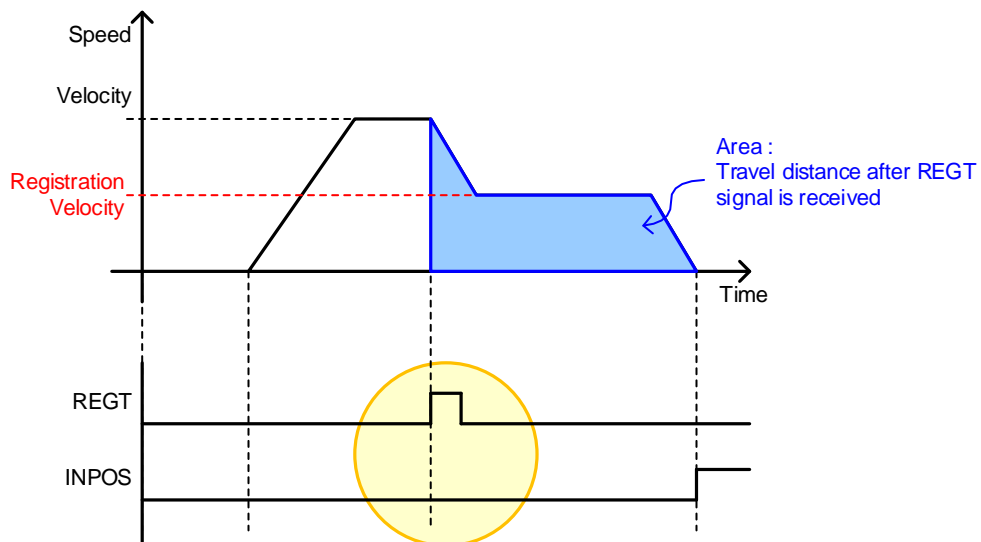

### 10.6.2.3 Blending Absolute / Relative Move

This operation type combines continuous indexes into one operation pattern.

When each index is finished, it does not stop at 0 velocity, but operates using the Next Index.

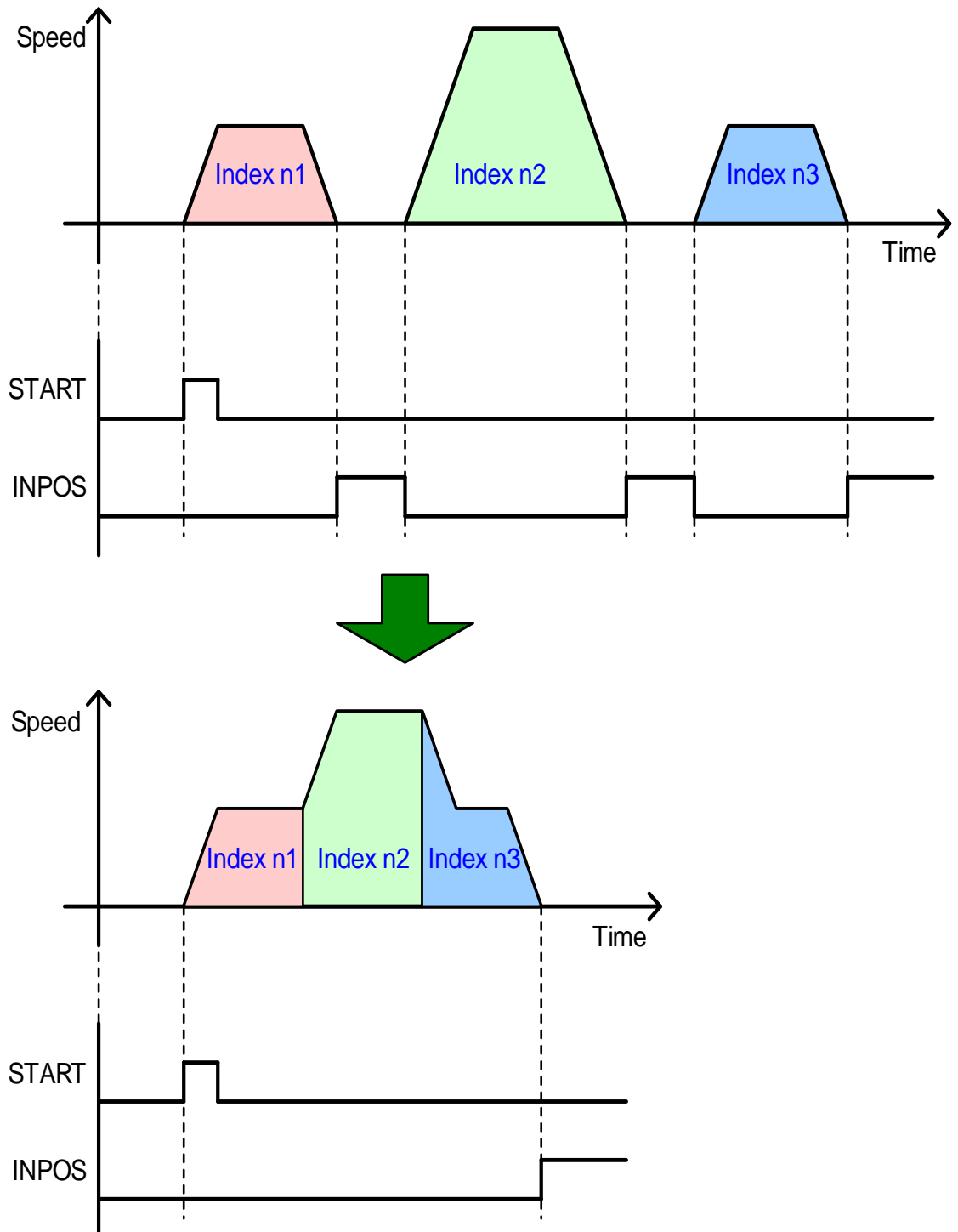



## 10.6.2.4 Rotary Absolute / Relative Move

### ■ Rotary Absolute Move

This can only be used when the coordinates are set to rotary coordinates.

The rotation direction is determined by the relationship between the start position and command position. If the start position is smaller than the command position, it rotates clockwise. In the opposite case, it rotates counterclockwise. At this time, it does not necessarily follow the shortest path.

You can set one or more turns for Distance (Modulo Factor: The value set in 0x240C) and enter a negative value (if Modulo Factor is 360°, -90° and 270° are the same). In this case, final position is determined considering the Modulo Factor. This is useful as you can enter a negative value to set it to rotate counterclockwise and pass the zero position.

Depending on the command value, it can rotate one turn or more.

The figure below shows an example of moving from 30° to 240° clockwise and from 300° to 240° counterclockwise.

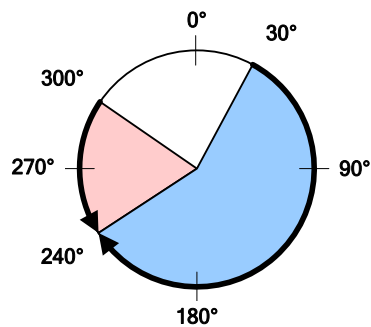

## ■ Rotary Relative Move

This can only be used when the coordinates are set to rotary coordinates.

If the command (Distance) is positive (+), it moves in the positive direction. If it is negative (-), it moves in the negative direction. You can set one or more turns for Distance (Modulo Factor: The value set in 0x240C) and rotate one or more turns depending on the command value.

The figure below shows an example of moving  $+180^\circ$  from  $30^\circ$  to  $210^\circ$  and moving  $-120^\circ$  from  $30^\circ$  to  $-90^\circ$ .

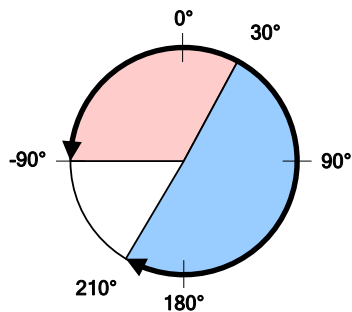

### 10.6.2.5 Rotary Shortest Move

This can only be used when the coordinates are set to rotary coordinates.

The operation direction is determined by which moving distance is shorter between the forward and reverse directions.

It only rotates within one cycle (Modulo Factor: The value set in 0x240C). The value set in Distance is processed as an absolute value.

The figure below shows an example of moving from  $30^\circ$  to  $310^\circ$  counterclockwise and from  $30^\circ$  to  $180^\circ$  clockwise, both of which are the shortest paths.

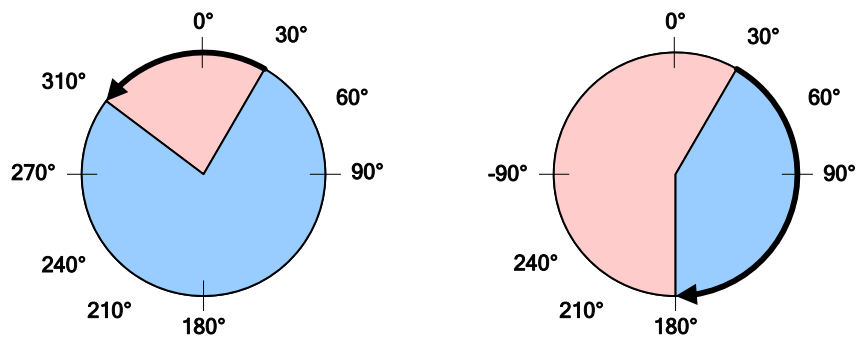

## 10.6.2.6 Rotary Positive / Negative Move

### ■ Rotary Positive Move

This can only be used when the coordinates are set to rotary coordinates.

It always moves in the positive (+) direction regardless of the start position and command position (Distance).

It only rotates within one cycle (Modulo Factor: The value set in 0x240C). The value set in Distance is processed as an absolute value.

The figure below shows an example of moving from 300° to 30° and from 30° to 180° clockwise.

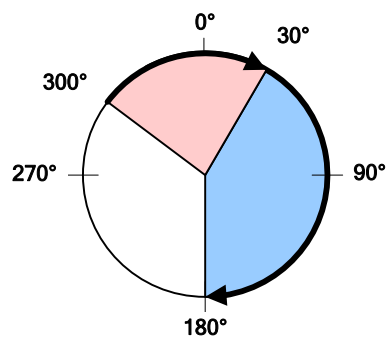

## ■ Rotary Negative Move

This can only be used when the coordinates are set to rotary coordinates.

It always moves in the negative (-) direction regardless of the start position and command position (Distance).

It only rotates within one cycle (Modulo Factor: The value set in 0x240C). The value set in Distance is processed as an absolute value.

The figure below shows an example of moving from 60° to 340° and from 340° to 180° counterclockwise.

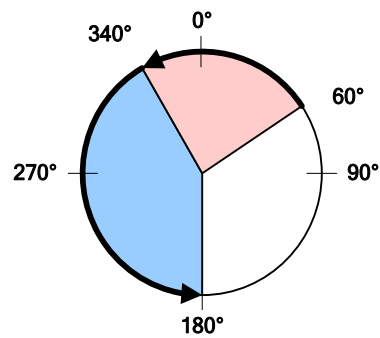

## 10.6.3 Functions of Index Input Signals

### ■ Pause

The current index operation pauses when a pause signal (rising edge) is received during the index operation.

It moves the remaining distance when a pause signal is received again (rising edge).

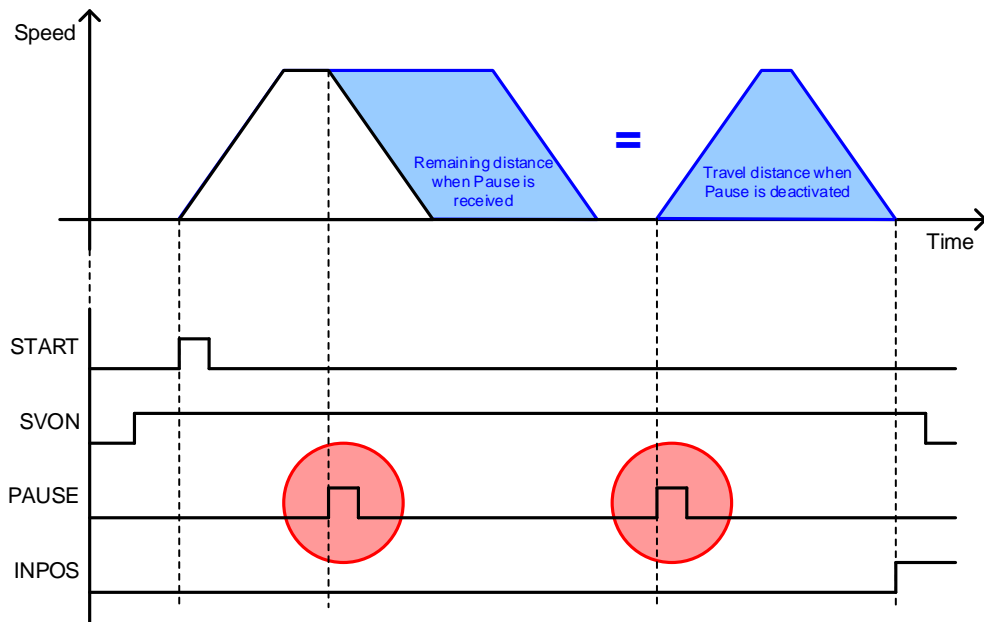

## ■ STOP

When a stop signal is received (rising edge), it stops with Stop Deceleration (0x6085) and terminates the index operation sequence.

When a start signal is received, it starts the operation from the index set in Start Index (0x3008).

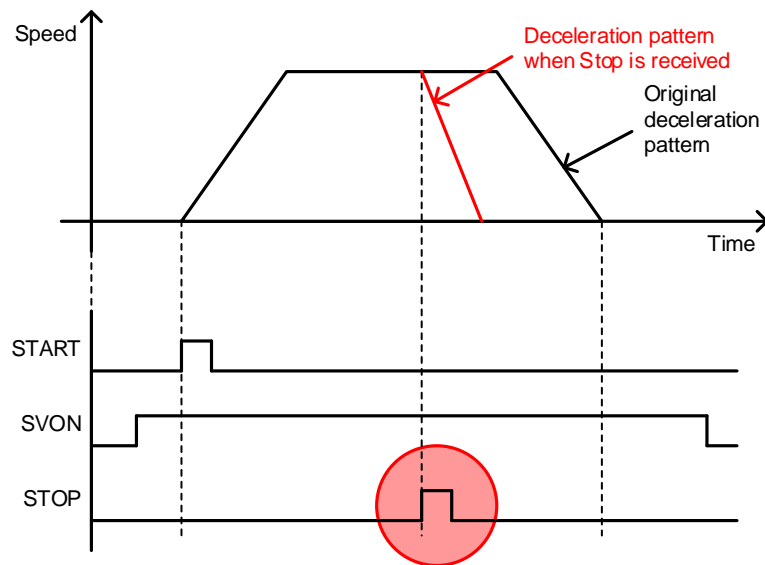

■ **HSTART (Start return to origin), ORG (Return to origin complete)**

When HSTART is received (rising edge), it starts returning to the origin. The HSTART signal that is received while returning to the origin is ignored.

Once it has returned to the origin, the ORG (Origin: Origin return complete) signal is output. If it starts returning to the origin, the ORG signal is reset to 0.

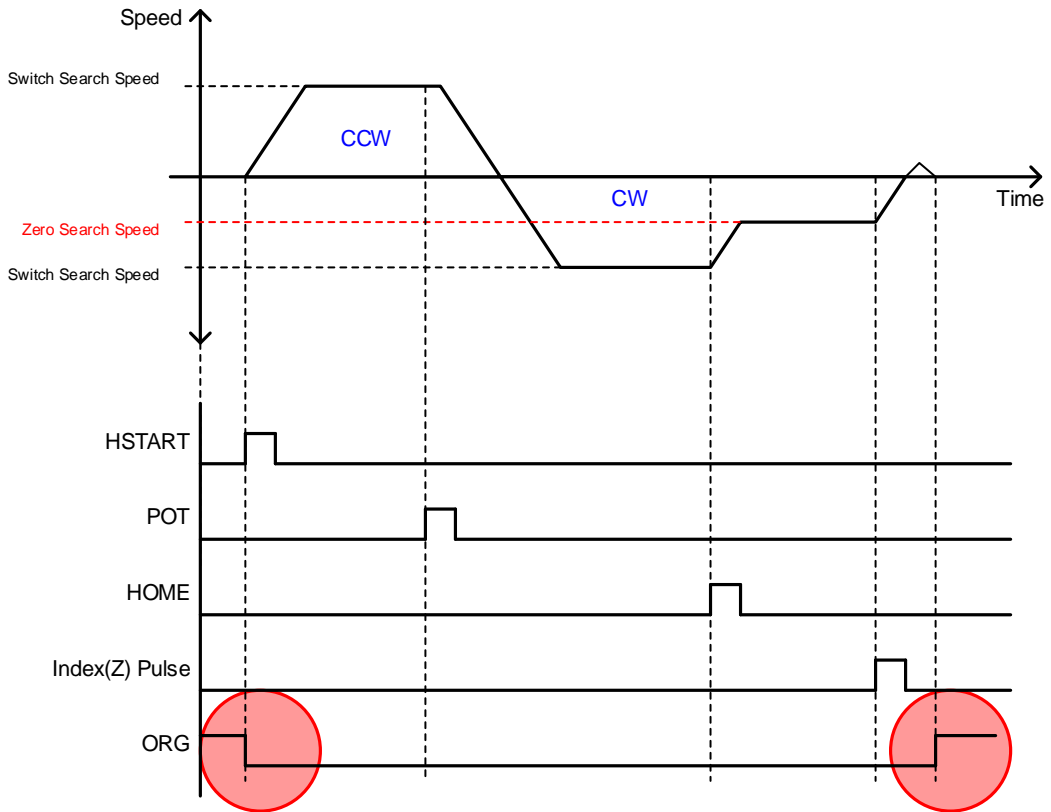



### ■ JSTART (Jog operation start)/JDIR (Jog operation direction)

In the case of machine adjustment and origin position alignment, you can use jog operation to move to an arbitrary position. The JSTART signal that is received from outside is used to start jog operation. The JDIR signal that is received from outside is used to change the rotation direction to run the servo motor. If you want to stop, use the stop signal that is received from outside. If the JSTART signal is on, it is in the speed control mode. If the JSTART signal is off, it switches to the previous operation mode.

Related Objects	Details
Jog Operation Speed (0x2300)	Refer to 10.4 Settings Related to Speed Control.
Speed Command Acceleration Time (0x2301)	
Speed Command Deceleration Time (0x2302)	
Speed Command S-Curve Time (0x2303)	

- Servo Motor Rotation Direction

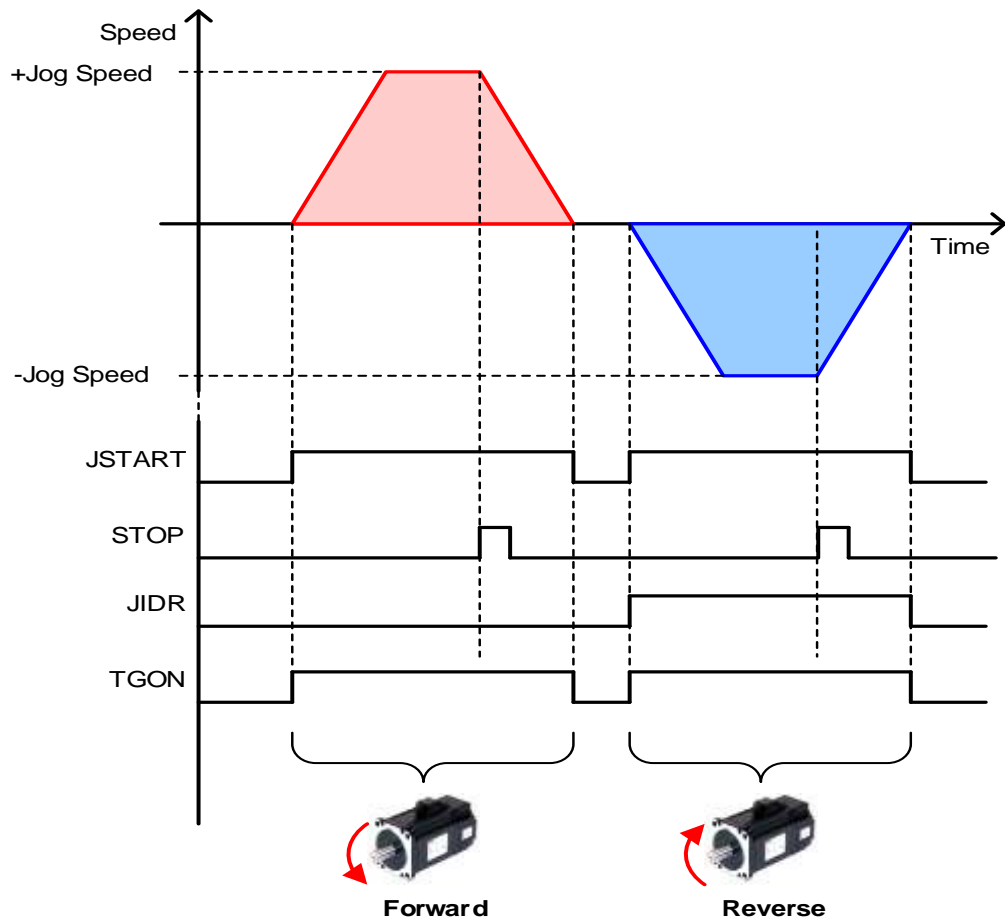

## 10.6.4 Functions of Index Output Signals

### ■ EOS (Index sequence complete)

If the index action is Stop or Wait for Start, the EOS (End of Sequence) signal is output after the index has finished.

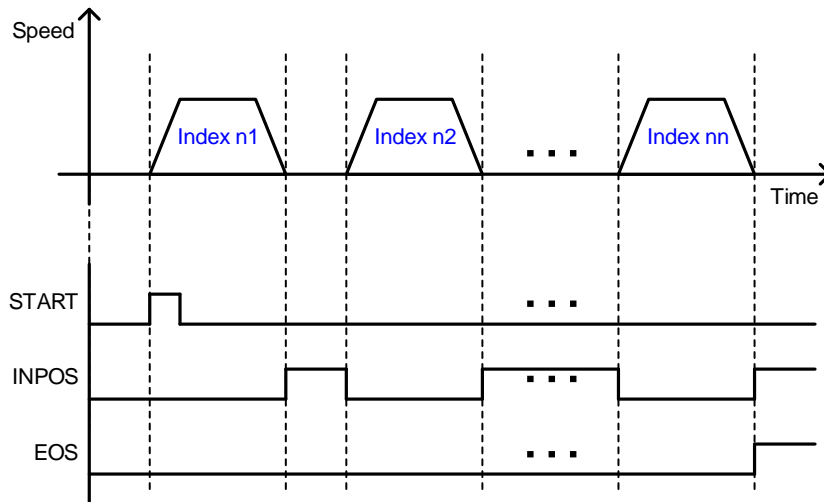

■ IOUT 0 - 5 (Index output 0 - 5)

The current index number is output by IOUT0 - 5. The following output is performed depending on the parameter 0x300A setting.

0x300A	IOUT Configuration						ALL
Variable type	Setting range	Initial value	Unit	Accessi bility	PDO assignment	Change attribute	Retentive
UINT	0 to 5	0	-	RW	No	Always	Yes

Settings	Setting details
0	The IOUT signal is output during the indexing position operation. The completed IOUT signal is output after the indexing position operation is completed.
1	The previously completed IOUT signal is output during the indexing position operation. The completed IOUT signal is output after the indexing position operation is completed.

■ Settings: 0

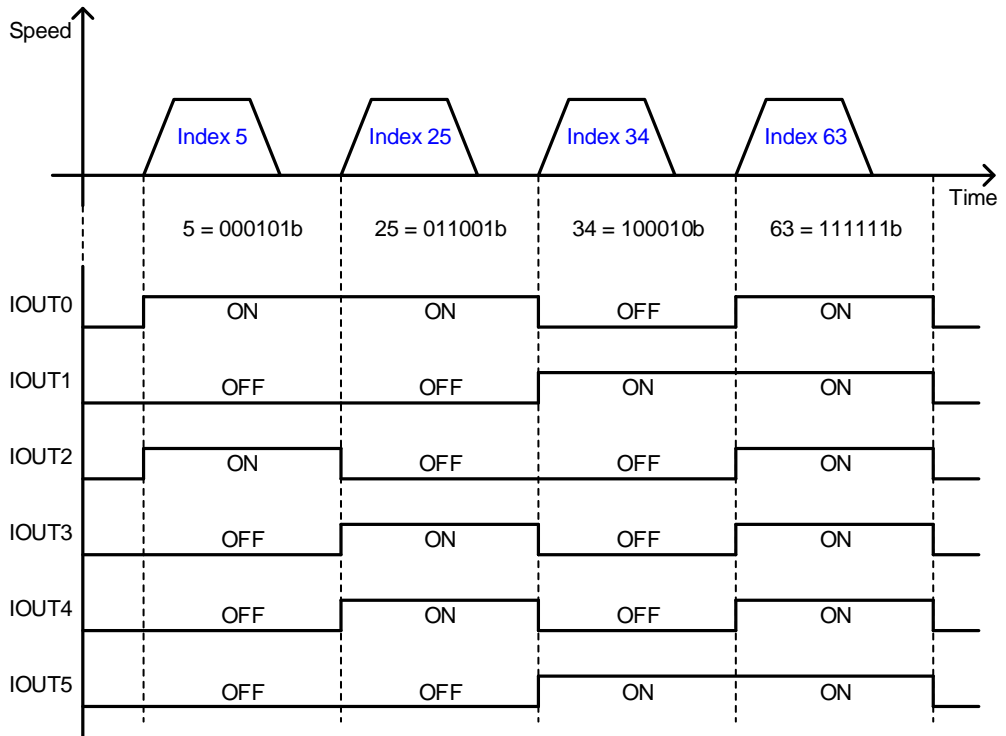

■ Settings: 1

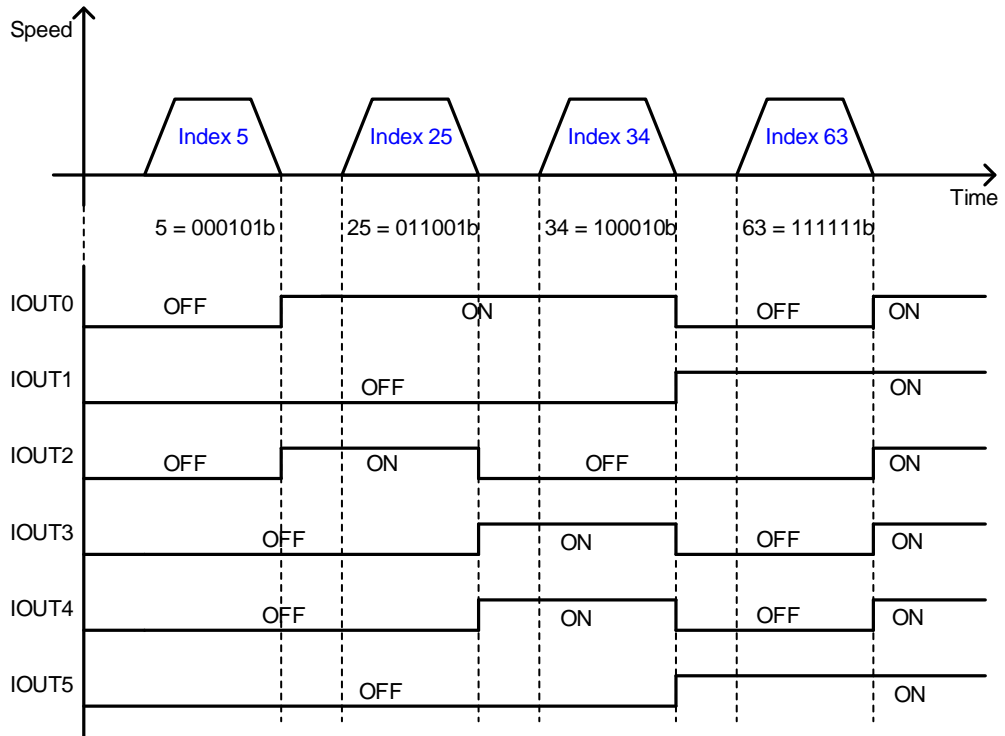

If the operation mode is changed and SVON signal is off (motor free-run status), the current position signals for index output are initialized. Initialized output statuses are the same as the index 0 operation status output. Therefore, start with Index 1 if possible.

### 10.6.5 Analog Speed Override

If the indexing position operation is performed as shown in the figure below, it can override the index speed based on the analog input. This function is used to set the analog input function select (0x222B) to analog speed override mode. You can adjust the offset of the received voltage by setting the analog speed override offset (0x221F). The unit is mV.

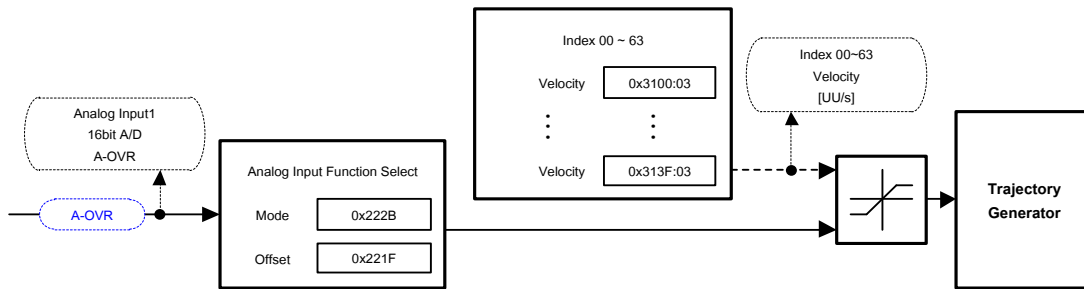

#### ■ A-OVR (Analog Speed Override)

The speed compared to the analog speed override voltage is shown below. If -10 V, 0 V, or 10 V is received, 0%, 100%, or 200% of the preset operation speed value is applied respectively as the speed override.

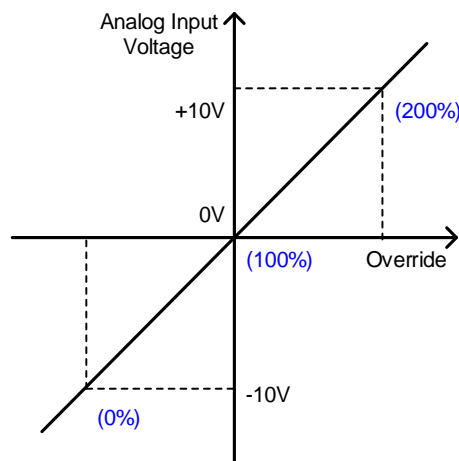

#### ■ Related Objects

Index	Sub Index	Name	Variable type	Accessibility	PDO Assignment	Unit
0x222B	-	Analog Input Function Select	UINT	RW	No	-
0x221F	-	Analog Velocity Input(command/Override) Offset	INT	RW	No	mV



## 10.7 Pulse Input Position Operation

You can use an upper-level controller that has the position determination function to carry out the pulse input type position control operation.

For this, control mode [0x3000] should be set to 1.

The basic internal block diagram of the pulse input type position control mode is shown below.

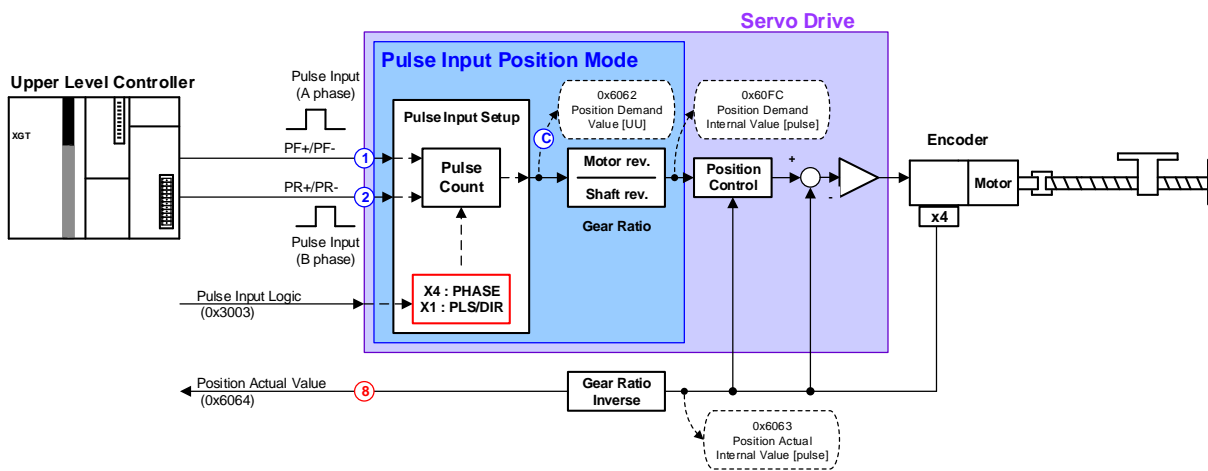

## 10.7.1 Setting Functions of Pulse Input Logic

This specifies the logic of the pulse row received from the upper level controller. The type of input pulses and rotation direction per logic are as follows:

Settings	Setting details
0	A-phase + B-phase, positive logic
1	CW + CCW, positive logic
2	Pulse + sign, positive logic
3	A-phase + B-phase, negative logic
4	CW + CCW, negative logic
5	Pulse + sign, negative logic

PF + PR		Forward Rotation	Reverse Rotation
A-phase + B-phase, positive logic	0	PULS (I/O-31) SIGN (I/O-33)	PULS (I/O-31) SIGN (I/O-33)
CW + CCW, positive logic	1	PULS (I/O-31) SIGN (I/O-33)	PULS (I/O-31) SIGN (I/O-33)
Pulse + sign, positive logic	2	PULS (I/O-31) SIGN (I/O-33)	PULS (I/O-31) SIGN (I/O-33)

PF + PR		Forward Rotation	Reverse Rotation
A-phase + B-phase, negative logic	3	PULS (I/O-31) SIGN (I/O-33)	PULS (I/O-31) SIGN (I/O-33)
CW + CCW, negative logic	4	PULS (I/O-31) SIGN (I/O-33)	PULS (I/O-31) SIGN (I/O-33)
Pulse + sign, negative logic	5	PULS (I/O-31) SIGN (I/O-33)	PULS (I/O-31) SIGN (I/O-33)

### ■ Related Objects

Index	Sub Index	Name	Variable type	Accessibility	PDO Assignment	Unit
0x3003	-	Pulse Input Logic Select	UINT	RW	No	-



## 10.7.2 Setting Functions of Pulse Input Filter

This specifies the frequency band of the digital filter defined for the pulse input. It can be used to reduce wiring noises.

The determination of the frequency bands is based on the input pulse width in accordance with the digital filter's characteristics.

Settings	Setting details
0	Do not use any filter.
1	500Khz (Min)
2	750Khz
3	1Mhz (Default)
4	1.25Mhz

### ■ Related Objects

Index	Sub Index	Name	Variable type	Accessibility	PDO Assignment	Unit
0x3004	-	Pulse Input Filter Select	UINT	RW	No	-

### 10.7.2.1 Setting Functions of PCLEAR

This specifies the operation mode when the position pulse clear (PCLR) signal is received. If a PCLR signal is received, the position error inside the drive becomes 0.

Settings	Setting details
0	Operate in edge mode.
1	Operate in level mode (torque: Maintained).
2	Operate in level mode (torque: 0)

#### ■ Related Objects

Index	Sub Index	Name	Variable type	Accessibility	PDO Assignment	Unit
0x3005	-	PCLEAR Mode Select	UINT	RW	No	-

### 10.7.2.2 Function Setting of INHIBIT

The INHIBIT function interrupts the command pulse counting.

When the command pulse inhibit (INHIB) signal is input, the operation mode is set in I/O Configuration (from 0x2200). This function is only active for the PulseInputPosition operation. The input pulses generated after the INHIB signal input are not counted as command pulses.

Settings	Setting details
ON	Turns on the command pulse inhibit function to inhibit input pulses.
OFF	Turns off the command pulse inhibit function to count input pulses.

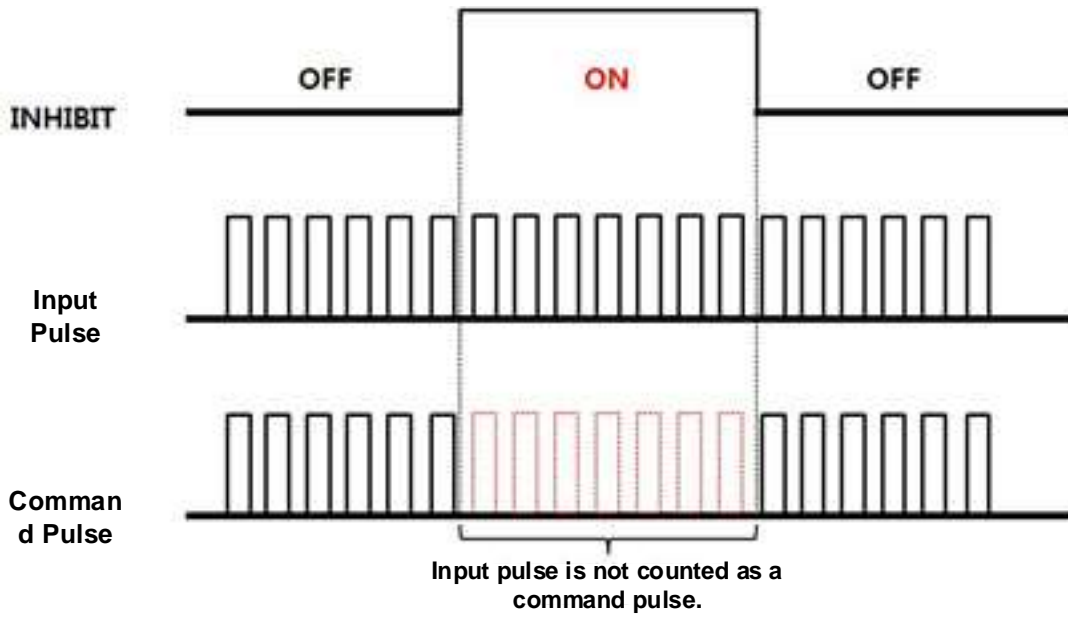

## 10.8 Speed Operation

### 10.8.1 Setting Functions of Speed Command Switch Select

It sets how to command the servo drive during the speed operation.

Index	Sub Index	Name	Variable type	Accessibility	PDO Assignment	Unit
0x231A	-	Velocity Command Switch Select	UINT	RW	No	-

Settings	Setting details
0	Analog speed command is used.
1	SPD1 and SPD2 contact points and analog speed command are used.
2	SPD1, SPD2, and SPD3 contact points and analog speed command are used.
3	Speed commands of SPD1, SPD2, and SPD3 contact points are used.

If the setting is 1 or 2 and the corresponding contact point is on, it uses the analog speed command.

E.g. 1) If the setting is 2 and the SPD1 and SPD2 contact points are on, the analog speed command 10 V is applied.

The motor operates at 100 rpm. The analog input speed command is ignored.

The operating speed is applied by a multi-speed command based on the parameter 0x2315 setting.

E.g. 2) If the setting is 2 and the SPD1, SPD2, and SPD3 contact points are on, the analog speed command 10 V is applied.

The motor operates at 1000 rpm. The speed command of the digital input/output contact point is ignored.

The operating speed is applied by an analog speed command voltage based on the parameter 0x2229 setting.

## 10.8.2 Analog Speed Command

If the speed command switch select setting is 0, 1, or 2, the speed can be controlled by an external analog voltage.

In order to input the command, apply differential -5V - +5V (10 Vpp) voltage to the No. 6 and 7 pins on the I/O connector.

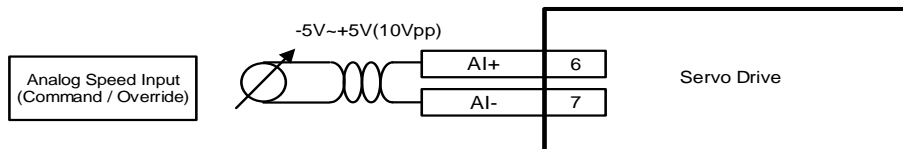

### ■ Related Objects

Index	Sub Index	Name	Variable type	Accessibility	PDO Assignment	Unit
0x2227	-	Analog Velocity Command Filter Time Constant	UINT	RW	No	-
0x2229	-	Analog Velocity Command Scale	INT	RW	No	-
0x222A	-	Analog Velocity Command Clamp Level	UINT	RW	No	-
0x222B	-	Analog Input Function Select	UINT	RW	No	-

### ■ Analog Speed Command Scale

This sets the analog speed command value per 1 V input in rpm. If the command voltage is the opposite (-), only the rotation direction is changed in the settings.

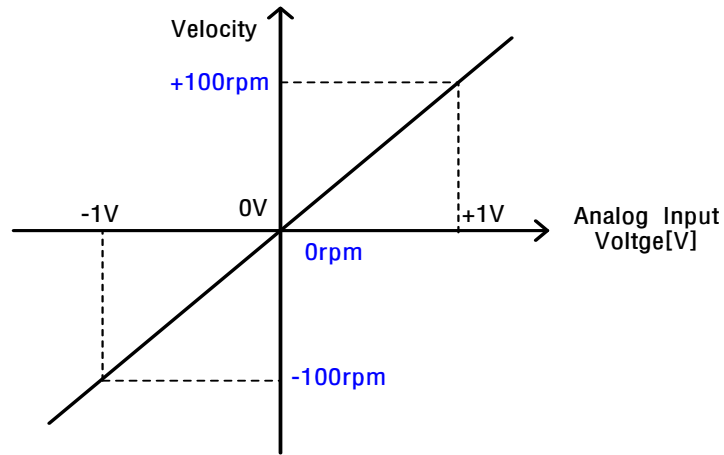

### ■ Analog Speed Command Clamp Level

There are cases where a certain level of voltage remains on the analog signal access circuit, even at the 0 speed command.

In this case, zero speed can be maintained for the voltage command that corresponds to the set speed value.

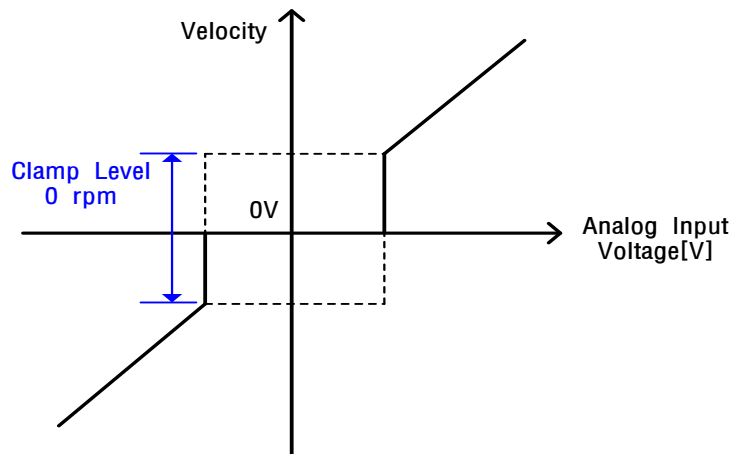

### 10.8.3 Multi-Stage Speed Command

If the speed command switch select setting is 1, 2, or 3, the speed can be controlled by the multi-stage speed inside the servo drive.

In order to use the digital speed command, you can either assign digital input SPD1, SPD2, and SPD3 signals to the I/O connector or control the digital input SPD1, SPD2, and SPD3 signals via communication.

■ **Speed settings for each digital input signal**

Input Device			Speed
SPD1	SPD2	SPD3	
X	X	X	Multi-Stage Speed Command 1 (Parameter 0x2312)
O	X	X	Multi-Stage Speed Command 2 (Parameter 0x2313)
X	O	X	Multi-Stage Speed Command 3 (Parameter 0x2314)
O	O	X	Multi-Stage Speed Command 4 (Parameter 0x2315)
X	X	O	Multi-Stage Speed Command 5 (Parameter 0x2316)
O	X	O	Multi-Stage Speed Command 6 (Parameter 0x2317)
X	O	O	Multi-Stage Speed Command 7 (Parameter 0x2318)
O	O	O	Multi-Stage Speed Command 8 (Parameter 0x2319)

## 10.9 Torque Operation

### 10.9.1 Analog Torque Command Scale

This sets the analog torque command value per 1 V input in 0.1% increments.

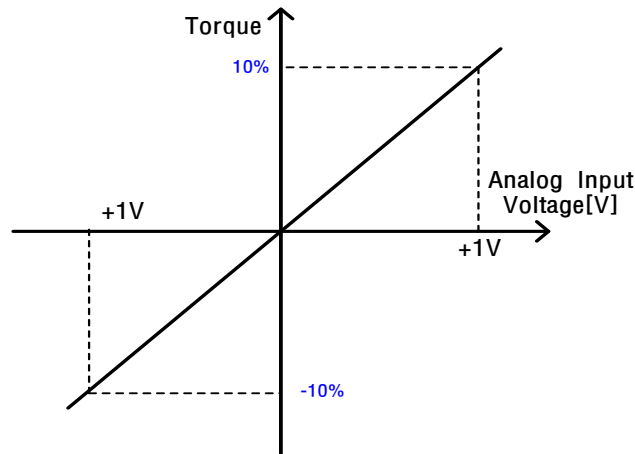

A related object is the 0x221C analog torque input (command/limit) scale, which is classified into two functions.

0x221C	Analog Torque Input(command/limit) Scale						ALL
Variable type	Setting range	Initial value	Unit	Accessibility	PDO assignment	Change attribute	Retentive
UINT	-1000 to 1000	100	0.1%/V	RW	No	Always	Yes

First, when torque operation is not applied

If the value of the torque limit function setting (0x2110) is 4 (analog torque limit), torque is limited by the analog input torque limit. Set the scale of the analog input value at this time.

Second, when torque operation is applied

In the case of torque operation, the parameter is used as the analog torque command scale. The selected value sets the torque command at an analog input voltage of  $\pm 10$  V as a percentage of the rated torque.

### 10.9.2 Speed Settings during Torque Operation

In the case of torque operation, motor speed is determined based on the settings of the 0x230D speed limit function.

Settings	Setting details
----------	-----------------



0	Limited by the speed limit value (0x230E)
1	Limited by the maximum motor speed

In the case of 0x230E torque control, the initial limit speed value is set to 1000 rpm.

Enter the desired speed value before operation.

■ Related Objects

Index	Sub Index	Name	Variable type	Accessibility	PDO Assignment	Unit
0x221C	-	Analog Torque Input(command/limit) Scale	UINT	RW	No	-
0x221D	-	Analog Torque Input(command/limit) Offset	INT	RW	No	-
0x2228	-	Analog Torque Command Filter Time Constant	UINT	RW	No	-
0x222B	-	Analog Input Function Select	UINT	RW	No	-
0x230D	-	Speed Limit Function Select	UINT	RW	No	-
0x230E	-	Speed Limit Value at Torque Control Mode	UINT	RW	No	-

## 10.10 Operation Mode Switching

Operation mode switching is supported depending on the drive control mode (0x3000) setting and digital input mode signal.

### ■ Control Mode (0x3000) Setting

Settings	Setting details
0	Indexing Position Mode
1	Pulse Input Position Mode
2	Velocity Mode
3	Torque Mode
4	Pulse input position operation or index position operation
5	Pulse input position operation or speed operation mode
6	Pulse input position operation or torque operation mode
7	Speed operation mode or torque operation mode
8	Index position operation mode or speed operation mode
9	Index position operation mode or torque operation mode

#### ■ Control Mode Setting: 4

This setting performs pulse input position operation as the default. When the digital input mode signal is received, it switches to the index position operation mode.

#### ■ Control Mode Setting: 5

This setting performs pulse input position operation as the default. When the digital input mode signal is received, it switches to the speed operation mode.

#### ■ Control Mode Setting: 6

This setting performs pulse input position operation as the default. When the digital input mode signal is received, it switches to the torque operation mode.

#### ■ Control Mode Setting: 7

This setting performs speed operation as the default. When the digital input mode signal is received, it switches to the torque operation mode.

#### ■ Control Mode Setting: 8

This setting performs index position operation as the default. When the digital input mode signal is received, it switches to the speed operation mode.

**■ Control Mode Setting: 9**

This setting performs index position operation as the default. When the digital input mode signal is received, it switches to the torque operation mode.

# 11. Object Dictionary

Object is a data structure including parameters, state variables, run commands (procedures), and etc. within a drive.

Object can be mainly divided into general object (from 0x1000) for EtherCAT communication, CiA402 object (from 0x6000) for CAN application over EtherCAT (CoE), and manufacturer specific object (from 0x2000) exclusively provided by this drive.

## 11.1 Data Type

The following table outlines the type and range of the data types used in this manual.

Code	Description	Range
SINT	Signed 8-bit	-128 ~ 127
USINT	Unsigned 8-bit	0 ~ 255
INT	Signed 16-bit	-32768 ~ 32767
UINT	Unsigned 16-bit	0 ~ 65535
DINT	Signed 32-bit	-21247483648 ~ 21247483647
UDINT	Unsigned 32-bit	0 ~ 4294967295
FP32	Float 32-bit	Single precision floating point
STRING	String Value	

## 11.2 General Objects

0x1000	Device Type						
Variable type	Setting range	Initial value	Unit	Accessibility	PDO assignment	Change attribute	Retentive
UDINT	-	0x00020192	-	RO	No	-	No

The following table lists device types and their functions.

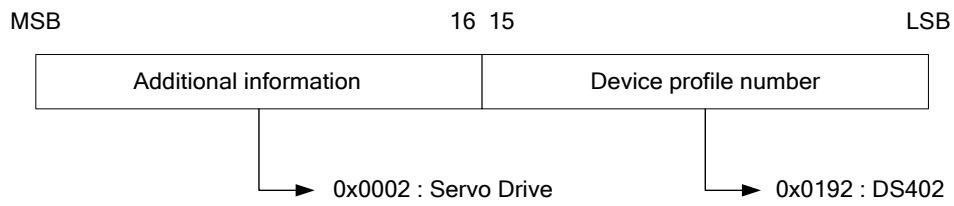

0x1001 Error Register							
Variable type	Setting range	Initial value	Unit	Accessibility	PDO assignment	Change attribute	Retentive
USINT	-	0x00	-	RO	No	-	No

The following table shows the error register values for each device. This value is stored in the emergency message.

Bit	Setting details
0	0: No error
	1: Error occurs
1 to 7	Reserved

0x1008 Device Name							
Variable type	Setting range	Initial value	Unit	Accessibility	PDO assignment	Change attribute	Retentive
STRING	-	-	-	RO	No	-	No

Represents the device name.

0x1009 Hardware Version							
Variable type	Setting range	Initial value	Unit	Accessibility	PDO assignment	Change attribute	Retentive
STRING	-	-	-	RO	No	-	No

Represents the hardware version of the device.

0x100A Software Version							
Variable type	Setting range	Initial value	Unit	Accessibility	PDO assignment	Change attribute	Retentive
STRING	-	-	-	RO	No	-	No

STRING	-	-	-	RO	No	-	No
--------	---	---	---	----	----	---	----

Represents the software version of the device.

0x1010 Store Parameters							
SubIndex 0		Number of entries					
Variable type	Setting range	Initial value	Unit	Accessibility	PDO assignment	Change attribute	Retentive
USINT	-	5	-	RO	No	-	No
SubIndex 1		Store all parameters					
Variable type	Setting range	Initial value	Unit	Accessibility	PDO assignment	Change attribute	Retentive
UDINT	0 to 0xFFFFFFFF	0	-	RW	No	-	No
SubIndex 2		Store communication parameters					
Variable type	Setting range	Initial value	Unit	Accessibility	PDO assignment	Change attribute	Retentive
UDINT	0 to 0xFFFFFFFF	0	-	RW	No	-	No
SubIndex 3		Store CiA402 parameters					
Variable type	Setting range	Initial value	Unit	Accessibility	PDO assignment	Change attribute	Retentive
UDINT	0 to 0xFFFFFFFF	0	-	RW	No	-	No
SubIndex 4		Store drive specific parameters					
Variable type	Setting range	Initial value	Unit	Accessibility	PDO assignment	Change attribute	Retentive
UDINT	0 to 0xFFFFFFFF	0	-	RW	No	-	No
SubIndex 5		Store index parameters					
Variable type	Setting range	Initial value	Unit	Accessibility	PDO assignment	Change attribute	Retentive
UDINT	0 to 0xFFFFFFFF	0	-	RW	No	-	No

Store the drive's parameters in the memory. To avoid any mistakes, store the parameters if the ASCII code value corresponding to "save" is written to the relevant SubIndex value.

	MSB	16	15	LSB
	e	v	a	s
ASCII Code	0x65	0x76	0x61	0x73

All parameters within the drive are stored when "save" is written to SubIndex 1.

(However, this does not apply to SubIndex 5. Save SubIndex 5 separately.)

Only communication parameters (from 0x1000) are stored when "save" is written to SubIndex 2.

Only CiA402 parameters (from 0x6000) are stored when "save" is written to SubIndex 3.

Only drive-specific parameters (from 0x2000) are stored when "save" is written to SubIndex 4.

(For SubIndex 4, 0x2000 - 0x3099 are saved.)

Only index parameters (from 0x3100) are stored when "save" is written to SubIndex 5.

0x1011		Restore Default Parameters					
SubIndex 0		Number of entries					
Variable type	Setting range	Initial value	Unit	Accessibility	PDO assignment	Change attribute	Retentive
USINT	-	5	-	RO	No	-	No
SubIndex 1		Restore all parameters					
Variable type	Setting range	Initial value	Unit	Accessibility	PDO assignment	Change attribute	Retentive
UDINT	0 to 0xFFFFFFFF	0	-	RW	No	-	No
SubIndex 2		Restore communication parameters					
Variable type	Setting range	Initial value	Unit	Accessibility	PDO assignment	Change attribute	Retentive
UDINT	0 to 0xFFFFFFFF	0	-	RW	No	-	No
SubIndex 3		Restore CiA402 parameters					
Variable type	Setting range	Initial value	Unit	Accessibility	PDO assignment	Change attribute	Retentive
UDINT	0 to 0xFFFFFFFF	0	-	RW	No	-	No
SubIndex 4		Restore drive specific parameters					
Variable type	Setting range	Initial value	Unit	Accessibility	PDO assignment	Change attribute	Retentive
UDINT	0 to 0xFFFFFFFF	0	-	RW	No	-	No
SubIndex 5		Restore index parameters					
Variable type	Setting range	Initial value	Unit	Accessibility	PDO assignment	Change attribute	Retentive
UDINT	0 to 0xFFFFFFFF	0	-	RW	No	-	No

Initialize the drive's parameters. To avoid any mistakes, initialize the parameters if the ASCII code value corresponding to "load" is written to the relevant SubIndex value.

	MSB	16	15	LSB
	d	a	o	l
ASCII Code	0x64	0x61	0x6F	0x6C

All parameters within the drive are initialized when "load" is written to SubIndex 1.

(However, this does not apply to SubIndex 5. Load SubIndex 5 separately.)

Only communication parameters (from 0x1000) are initialized when "load" is written to SubIndex 2.

Only CiA402 parameters (from 0x6000) are initialized when "load" is written to SubIndex 3.

Only drive-specific parameters (from 0x2000) are initialized when "load" is written to SubIndex 4.

(For SubIndex 4, 0x2000 - 0x3099 are initialized.)

Only index parameters (from 0x3100) are initialized when "load" is written to SubIndex 5.

To apply the initialized value, you need to cycle the power of the drive.

0x1018		Identity Object					
SubIndex 0		Number of entries					
Variable type	Setting range	Initial value	Unit	Accessibility	PDO assignment	Change attribute	Retentive
USINT	-	4	-	RO	No	-	No
SubIndex 1		Vendor ID					
Variable type	Setting range	Initial value	Unit	Accessibility	PDO assignment	Change attribute	Retentive
UDINT	-	0x00007595	-	RO	No	-	No
SubIndex 2		Product code					
Variable type	Setting range	Initial value	Unit	Accessibility	PDO assignment	Change attribute	Retentive
UDINT	-	0x00010001	-	RO	No	-	No
SubIndex 3		Revision number					
Variable	Setting range	Initial value	Unit	Accessibility	PDO	Change	Retentive



type				ty	assignment	attribute	e
UDINT	-	-	-	RO	No	-	No
SubIndex 4		Serial number					
Variable type	Setting range	Initial value	Unit	Accessibili ty	PDO assignment	Change attribute	Retentiv e
UDINT	-	-	-	RO	No	-	No

Represents the device information.

0x1600		1 <sup>st</sup> Receive PDO Mapping					
SubIndex 0		Number of entries					
Variable type	Setting range	Initial value	Unit	Accessibility	PDO assignment	Change attribute	Retentive
USINT	0 to 10	5	-	RW	No	PREOP	Yes
SubIndex 1		Mapping entry 1					
Variable type	Setting range	Initial value	Unit	Accessibility	PDO assignment	Change attribute	Retentive
UDINT	0 to 0xFFFFFFFF	0x60400010	-	RW	No	PREOP	Yes
SubIndex 2		Mapping entry 2					
Variable type	Setting range	Initial value	Unit	Accessibility	PDO assignment	Change attribute	Retentive
UDINT	0 to 0xFFFFFFFF	0x60710010	-	RW	No	PREOP	Yes
SubIndex 3		Mapping entry 3					
Variable type	Setting range	Initial value	Unit	Accessibility	PDO assignment	Change attribute	Retentive
UDINT	0 to 0xFFFFFFFF	0x607A0020	-	RW	No	PREOP	Yes
SubIndex 4		Mapping entry 4					
Variable type	Setting range	Initial value	Unit	Accessibility	PDO assignment	Change attribute	Retentive
UDINT	0 to 0xFFFFFFFF	0x60600008	-	RW	No	PREOP	Yes
SubIndex 5		Mapping entry 5					
Variable type	Setting range	Initial value	Unit	Accessibility	PDO assignment	Change attribute	Retentive
UDINT	0 to 0xFFFFFFFF	0x60B80010	-	RW	No	PREOP	Yes
SubIndex 6		Mapping entry 6					
Variable type	Setting range	Initial value	Unit	Accessibility	PDO assignment	Change attribute	Retentive
UDINT	0 to 0xFFFFFFFF	-	-	RW	No	PREOP	Yes
SubIndex 7		Mapping entry 7					
Variable type	Setting range	Initial value	Unit	Accessibility	PDO assignment	Change attribute	Retentive
UDINT	0 to 0xFFFFFFFF	-	-	RW	No	PREOP	Yes
SubIndex 8		Mapping entry 8					
Variable type	Setting range	Initial value	Unit	Accessibility	PDO assignment	Change attribute	Retentive

UDINT	0 to 0xFFFFFFFF	-	-	RW	No	PREOP	Yes
SubIndex 9		Mapping entry 9					
Variable type	Setting range	Initial value	Unit	Accessibility	PDO assignment	Change attribute	Retentive
UDINT	0 to 0xFFFFFFFF	-	-	RW	No	PREOP	Yes
SubIndex 10		Mapping entry 10					
Variable type	Setting range	Initial value	Unit	Accessibility	PDO assignment	Change attribute	Retentive
UDINT	0 to 0xFFFFFFFF	-	-	RW	No	PREOP	Yes

PDO Mapping :

Configure the Process Data Objects (PDO) to perform real-time data transfer through the CANopen over EtherCAT protocol. This drive can freely map up to 10 objects of PDOs for transmission/reception, respectively. Use 0x1600 - 0x1603 to set the receiving PDO mapping, and 0x1A00 - 0x1A03 to set the transmitting PDO mapping. Configure information about the objects below that you want to assign to items 1 to 10 (SubIndex 1 - 10). You have to set the number of the objects to be assigned for the number of items (SubIndex 0).

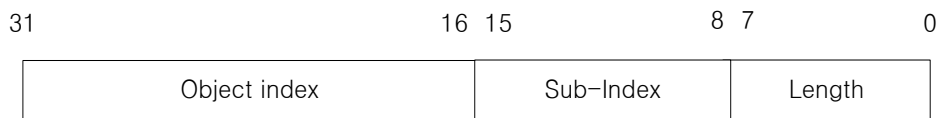

Bit 0-7: Bit lengths of objects to be mapped (e.g. displayed as 0x20 for 32-bit data)

Bit 8-15: SubIndex of objects to be mapped

Bit 16-31: Index of objects to be mapped

0x1601	2nd Receive PDO Mapping						
SubIndex 0		Number of entries					
Variable type	Setting range	Initial value	Unit	Accessibility	PDO assignment	Change attribute	Retentive
USINT	0 to 10	4	-	RW	No	PREOP	Yes
SubIndex 1		Mapping entry 1					
Variable type	Setting range	Initial value	Unit	Accessibility	PDO assignment	Change attribute	Retentive
UDINT	0 to 0xFFFFFFFF	0x60400010	-	RW	No	PREOP	Yes
SubIndex 2		Mapping entry 2					
Variable type	Setting range	Initial value	Unit	Accessibility	PDO assignment	Change attribute	Retentive
UDINT	0 to 0xFFFFFFFF	0x607A0020	-	RW	No	PREOP	Yes
SubIndex 3		Mapping entry 3					
Variable type	Setting range	Initial value	Unit	Accessibility	PDO assignment	Change attribute	Retentive
UDINT	0 to 0xFFFFFFFF	0x60B80010	-	RW	No	PREOP	Yes
SubIndex 4		Mapping entry 4					
Variable type	Setting range	Initial value	Unit	Accessibility	PDO assignment	Change attribute	Retentive
UDINT	0 to 0xFFFFFFFF	0x60FE0120	-	RW	No	PREOP	Yes
SubIndex 5		Mapping entry 5					
Variable type	Setting range	Initial value	Unit	Accessibility	PDO assignment	Change attribute	Retentive
UDINT	0 to 0xFFFFFFFF	-	-	RW	No	PREOP	Yes
SubIndex 6		Mapping entry 6					

Variable type	Setting range	Initial value	Unit	Accessibility	PDO assignment	Change attribute	Retentive
UDINT	0 to 0xFFFFFFFF	-	-	RW	No	PREOP	Yes
SubIndex 7		Mapping entry 7					
Variable type	Setting range	Initial value	Unit	Accessibility	PDO assignment	Change attribute	Retentive
UDINT	0 to 0xFFFFFFFF	-	-	RW	No	PREOP	Yes
SubIndex 8		Mapping entry 8					
Variable type	Setting range	Initial value	Unit	Accessibility	PDO assignment	Change attribute	Retentive
UDINT	0 to 0xFFFFFFFF	-	-	RW	No	PREOP	Yes
SubIndex 9		Mapping entry 9					
Variable type	Setting range	Initial value	Unit	Accessibility	PDO assignment	Change attribute	Retentive
UDINT	0 to 0xFFFFFFFF	-	-	RW	No	PREOP	Yes
SubIndex 10		Mapping entry 10					
Variable type	Setting range	Initial value	Unit	Accessibility	PDO assignment	Change attribute	Retentive
UDINT	0 to 0xFFFFFFFF	-	-	RW	No	PREOP	Yes

Refer to the description of 0x1600.

0x1602	3rd Receive PDO Mapping						
SubIndex 0		Number of entries					
Variable type	Setting range	Initial value	Unit	Accessibility	PDO assignment	Change attribute	Retentive
USINT	0 to 10	4	-	RW	No	PREOP	Yes
SubIndex 1		Mapping entry 1					
Variable type	Setting range	Initial value	Unit	Accessibility	PDO assignment	Change attribute	Retentive
UDINT	0 to 0xFFFFFFFF	0x60400010	-	RW	No	PREOP	Yes
SubIndex 2		Mapping entry 2					
Variable type	Setting range	Initial value	Unit	Accessibility	PDO assignment	Change attribute	Retentive
UDINT	0 to 0xFFFFFFFF	0x60FF0020	-	RW	No	PREOP	Yes
SubIndex 3		Mapping entry 3					
Variable type	Setting range	Initial value	Unit	Accessibility	PDO assignment	Change attribute	Retentive

UDINT	0 to 0xFFFFFFFF	0x60B80010	-	RW	No	PREOP	Yes
SubIndex 4		Mapping entry 4					
Variable type	Setting range	Initial value	Unit	Accessibility	PDO assignment	Change attribute	Retentive
UDINT	0 to 0xFFFFFFFF	0x60FE0120	-	RW	No	PREOP	Yes
SubIndex 5		Mapping entry 5					
Variable type	Setting range	Initial value	Unit	Accessibility	PDO assignment	Change attribute	Retentive
UDINT	0 to 0xFFFFFFFF	-	-	RW	No	PREOP	Yes
SubIndex 6		Mapping entry 6					
Variable type	Setting range	Initial value	Unit	Accessibility	PDO assignment	Change attribute	Retentive
UDINT	0 to 0xFFFFFFFF	-	-	RW	No	PREOP	Yes
SubIndex 7		Mapping entry 7					
Variable type	Setting range	Initial value	Unit	Accessibility	PDO assignment	Change attribute	Retentive
UDINT	0 to 0xFFFFFFFF	-	-	RW	No	PREOP	Yes
SubIndex 8		Mapping entry 8					
Variable type	Setting range	Initial value	Unit	Accessibility	PDO assignment	Change attribute	Retentive
UDINT	0 to 0xFFFFFFFF	-	-	RW	No	PREOP	Yes
SubIndex 9		Mapping entry 9					
Variable type	Setting range	Initial value	Unit	Accessibility	PDO assignment	Change attribute	Retentive
UDINT	0 to 0xFFFFFFFF	-	-	RW	No	PREOP	Yes
SubIndex 10		Mapping entry 10					
Variable type	Setting range	Initial value	Unit	Accessibility	PDO assignment	Change attribute	Retentive
UDINT	0 to 0xFFFFFFFF	-	-	RW	No	PREOP	Yes

Refer to the description of 0x1600.

0x1603	4th Receive PDO Mapping						
SubIndex 0		Number of entries					
Variable type	Setting range	Initial value	Unit	Accessibility	PDO assignment	Change attribute	Retentive
USINT	0 to 10	4	-	RW	No	PREOP	Yes
SubIndex 1		Mapping entry 1					

Variable type	Setting range	Initial value	Unit	Accessibility	PDO assignment	Change attribute	Retentive
UDINT	0 to 0xFFFFFFFF	0x60400010	-	RW	No	PREOP	Yes
SubIndex 2		Mapping entry 2					
Variable type	Setting range	Initial value	Unit	Accessibility	PDO assignment	Change attribute	Retentive
UDINT	0 to 0xFFFFFFFF	0x60710010	-	RW	No	PREOP	Yes
SubIndex 3		Mapping entry 3					
Variable type	Setting range	Initial value	Unit	Accessibility	PDO assignment	Change attribute	Retentive
UDINT	0 to 0xFFFFFFFF	0x60B80010	-	RW	No	PREOP	Yes
SubIndex 4		Mapping entry 4					
Variable type	Setting range	Initial value	Unit	Accessibility	PDO assignment	Change attribute	Retentive
UDINT	0 to 0xFFFFFFFF	0x60FE0120	-	RW	No	PREOP	Yes
SubIndex 5		Mapping entry 5					
Variable type	Setting range	Initial value	Unit	Accessibility	PDO assignment	Change attribute	Retentive
UDINT	0 to 0xFFFFFFFF	-	-	RW	No	PREOP	Yes
SubIndex 6		Mapping entry 6					
Variable type	Setting range	Initial value	Unit	Accessibility	PDO assignment	Change attribute	Retentive
UDINT	0 to 0xFFFFFFFF	-	-	RW	No	PREOP	Yes
SubIndex 7		Mapping entry 7					
Variable type	Setting range	Initial value	Unit	Accessibility	PDO assignment	Change attribute	Retentive
UDINT	0 to 0xFFFFFFFF	-	-	RW	No	PREOP	Yes
SubIndex 8		Mapping entry 8					
Variable type	Setting range	Initial value	Unit	Accessibility	PDO assignment	Change attribute	Retentive
UDINT	0 to 0xFFFFFFFF	-	-	RW	No	PREOP	Yes
SubIndex 9		Mapping entry 9					
Variable type	Setting range	Initial value	Unit	Accessibility	PDO assignment	Change attribute	Retentive
UDINT	0 to 0xFFFFFFFF	-	-	RW	No	PREOP	Yes
SubIndex 10		Mapping entry 10					
Variable type	Setting range	Initial value	Unit	Accessibility	PDO assignment	Change attribute	Retentive

UDINT	0 to 0xFFFFFFFF	-	-	RW	No	PREOP	Yes
-------	-----------------	---	---	----	----	-------	-----

Refer to the description of 0x1600.

0x1A00	1 <sup>st</sup> Transmit PDO Mapping						
SubIndex 0		Number of entries					
Variable type	Setting range	Initial value	Unit	Accessibility	PDO assignment	Change attribute	Retentive
USINT	0 to 10	10	-	RW	No	PREOP	Yes
SubIndex 1		Mapping entry 1					
Variable type	Setting range	Initial value	Unit	Accessibility	PDO assignment	Change attribute	Retentive
UDINT	0 to 0xFFFFFFFF	0x60410010	-	RW	No	PREOP	Yes
SubIndex 2		Mapping entry 2					
Variable type	Setting range	Initial value	Unit	Accessibility	PDO assignment	Change attribute	Retentive
UDINT	0 to 0xFFFFFFFF	0x60770010	-	RW	No	PREOP	Yes
SubIndex 3		Mapping entry 3					
Variable type	Setting range	Initial value	Unit	Accessibility	PDO assignment	Change attribute	Retentive
UDINT	0 to 0xFFFFFFFF	0x60640020	-	RW	No	PREOP	Yes
SubIndex 4		Mapping entry 4					
Variable type	Setting range	Initial value	Unit	Accessibility	PDO assignment	Change attribute	Retentive
UDINT	0 to 0xFFFFFFFF	0x60F40020	-	RW	No	PREOP	Yes
SubIndex 5		Mapping entry 5					
Variable type	Setting range	Initial value	Unit	Accessibility	PDO assignment	Change attribute	Retentive
UDINT	0 to 0xFFFFFFFF	0x60FD0020	-	RW	No	PREOP	Yes
SubIndex 6		Mapping entry 6					
Variable type	Setting range	Initial value	Unit	Accessibility	PDO assignment	Change attribute	Retentive
UDINT	0 to 0xFFFFFFFF	0x60610008	-	RW	No	PREOP	Yes
SubIndex 7		Mapping entry 7					
Variable type	Setting range	Initial value	Unit	Accessibility	PDO assignment	Change attribute	Retentive
UDINT	0 to 0xFFFFFFFF	0x26010010	-	RW	No	PREOP	Yes
SubIndex 8		Mapping entry 8					



Variable type	Setting range	Initial value	Unit	Accessibility	PDO assignment	Change attribute	Retentive
UDINT	0 to 0xFFFFFFFF	0x26000010	-	RW	No	PREOP	Yes
SubIndex 9		Mapping entry 9					
Variable type	Setting range	Initial value	Unit	Accessibility	PDO assignment	Change attribute	Retentive
UDINT	0 to 0xFFFFFFFF	0x60B90010	-	RW	No	PREOP	Yes
SubIndex 10		Mapping entry 10					
Variable type	Setting range	Initial value	Unit	Accessibility	PDO assignment	Change attribute	Retentive
UDINT	0 to 0xFFFFFFFF	0x60BA0020	-	RW	No	PREOP	Yes

Refer to the description of 0x1600.

0x1A01		2nd Transmit PDO Mapping					
SubIndex 0		Number of entries					
Variable type	Setting range	Initial value	Unit	Accessibility	PDO assignment	Change attribute	Retentive
USINT	0 to 10	6	-	RW	No	PREOP	Yes
SubIndex 1		Mapping entry 1					
Variable type	Setting range	Initial value	Unit	Accessibility	PDO assignment	Change attribute	Retentive
UDINT	0 to 0xFFFFFFFF	0x60410010	-	RW	No	PREOP	Yes
SubIndex 2		Mapping entry 2					
Variable type	Setting range	Initial value	Unit	Accessibility	PDO assignment	Change attribute	Retentive
UDINT	0 to 0xFFFFFFFF	0x60640020	-	RW	No	PREOP	Yes
SubIndex 3		Mapping entry 3					
Variable type	Setting range	Initial value	Unit	Accessibility	PDO assignment	Change attribute	Retentive
UDINT	0 to 0xFFFFFFFF	0x60F40020	-	RW	No	PREOP	Yes
SubIndex 4		Mapping entry 4					
Variable type	Setting range	Initial value	Unit	Accessibility	PDO assignment	Change attribute	Retentive
UDINT	0 to 0xFFFFFFFF	0x60B90010	-	RW	No	PREOP	Yes
SubIndex 5		Mapping entry 5					
Variable type	Setting range	Initial value	Unit	Accessibility	PDO assignment	Change attribute	Retentive

UDINT	0 to 0xFFFFFFFF	0x60BA0020	-	RW	No	PREOP	Yes
SubIndex 6		Mapping entry 6					
Variable type	Setting range	Initial value	Unit	Accessibility	PDO assignment	Change attribute	Retentive
UDINT	0 to 0xFFFFFFFF	0x60FD0020	-	RW	No	PREOP	Yes
SubIndex 7		Mapping entry 7					
Variable type	Setting range	Initial value	Unit	Accessibility	PDO assignment	Change attribute	Retentive
UDINT	0 to 0xFFFFFFFF	-	-	RW	No	PREOP	Yes
SubIndex 8		Mapping entry 8					
Variable type	Setting range	Initial value	Unit	Accessibility	PDO assignment	Change attribute	Retentive
UDINT	0 to 0xFFFFFFFF	-	-	RW	No	PREOP	Yes
SubIndex 9		Mapping entry 9					
Variable type	Setting range	Initial value	Unit	Accessibility	PDO assignment	Change attribute	Retentive
UDINT	0 to 0xFFFFFFFF	-	-	RW	No	PREOP	Yes
SubIndex 10		Mapping entry 10					
Variable type	Setting range	Initial value	Unit	Accessibility	PDO assignment	Change attribute	Retentive
UDINT	0 to 0xFFFFFFFF	-	-	RW	No	PREOP	Yes

Refer to the description of 0x1600.

0x1A02	3rd Transmit PDO Mapping						
SubIndex 0		Number of entries					
Variable type	Setting range	Initial value	Unit	Accessibility	PDO assignment	Change attribute	Retentive
USINT	0 to 10	5	-	RW	No	PREOP	Yes
SubIndex 1		Mapping entry 1					
Variable type	Setting range	Initial value	Unit	Accessibility	PDO assignment	Change attribute	Retentive
UDINT	0 to 0xFFFFFFFF	0x60410010	-	RW	No	PREOP	Yes
SubIndex 2		Mapping entry 2					
Variable type	Setting range	Initial value	Unit	Accessibility	PDO assignment	Change attribute	Retentive
UDINT	0 to 0xFFFFFFFF	0x60640020	-	RW	No	PREOP	Yes
SubIndex 3		Mapping entry 3					

Variable type	Setting range	Initial value	Unit	Accessibility	PDO assignment	Change attribute	Retentive
UDINT	0 to 0xFFFFFFFF	0x60B90010	-	RW	No	PREOP	Yes
SubIndex 4		Mapping entry 4					
Variable type	Setting range	Initial value	Unit	Accessibility	PDO assignment	Change attribute	Retentive
UDINT	0 to 0xFFFFFFFF	0x60BA0020	-	RW	No	PREOP	Yes
SubIndex 5		Mapping entry 5					
Variable type	Setting range	Initial value	Unit	Accessibility	PDO assignment	Change attribute	Retentive
UDINT	0 to 0xFFFFFFFF	0x60FD0020	-	RW	No	PREOP	Yes
SubIndex 6		Mapping entry 6					
Variable type	Setting range	Initial value	Unit	Accessibility	PDO assignment	Change attribute	Retentive
UDINT	0 to 0xFFFFFFFF	-	-	RW	No	PREOP	Yes
SubIndex 7		Mapping entry 7					
Variable type	Setting range	Initial value	Unit	Accessibility	PDO assignment	Change attribute	Retentive
UDINT	0 to 0xFFFFFFFF	-	-	RW	No	PREOP	Yes
SubIndex 8		Mapping entry 8					
Variable type	Setting range	Initial value	Unit	Accessibility	PDO assignment	Change attribute	Retentive
UDINT	0 to 0xFFFFFFFF	-	-	RW	No	PREOP	Yes
SubIndex 9		Mapping entry 9					
Variable type	Setting range	Initial value	Unit	Accessibility	PDO assignment	Change attribute	Retentive
UDINT	0 to 0xFFFFFFFF	-	-	RW	No	PREOP	Yes
SubIndex 10		Mapping entry 10					
Variable type	Setting range	Initial value	Unit	Accessibility	PDO assignment	Change attribute	Retentive
UDINT	0 to 0xFFFFFFFF	-	-	RW	No	PREOP	Yes

Refer to the description of 0x1600.

0x1A03 4th Transmit PDO Mapping							
SubIndex 0		Number of entries					
Variable type	Setting range	Initial value	Unit	Accessibility	PDO assignment	Change attribute	Retentive

USINT	0 to 10	5	-	RW	No	PREOP	Yes
SubIndex 1		Mapping entry 1					
Variable type	Setting range	Initial value	Unit	Accessibility	PDO assignment	Change attribute	Retentive
UDINT	0 to 0xFFFFFFFF	0x60410010	-	RW	No	PREOP	Yes
SubIndex 2		Mapping entry 2					
Variable type	Setting range	Initial value	Unit	Accessibility	PDO assignment	Change attribute	Retentive
UDINT	0 to 0xFFFFFFFF	0x60640020	-	RW	No	PREOP	Yes
SubIndex 3		Mapping entry 3					
Variable type	Setting range	Initial value	Unit	Accessibility	PDO assignment	Change attribute	Retentive
UDINT	0 to 0xFFFFFFFF	0x60B90010	-	RW	No	PREOP	Yes
SubIndex 4		Mapping entry 4					
Variable type	Setting range	Initial value	Unit	Accessibility	PDO assignment	Change attribute	Retentive
UDINT	0 to 0xFFFFFFFF	0x60BA0020	-	RW	No	PREOP	Yes
SubIndex 5		Mapping entry 5					
Variable type	Setting range	Initial value	Unit	Accessibility	PDO assignment	Change attribute	Retentive
UDINT	0 to 0xFFFFFFFF	0x60FD0020	-	RW	No	PREOP	Yes
SubIndex 6		Mapping entry 6					
Variable type	Setting range	Initial value	Unit	Accessibility	PDO assignment	Change attribute	Retentive
UDINT	0 to 0xFFFFFFFF	-	-	RW	No	PREOP	Yes
SubIndex 7		Mapping entry 7					
Variable type	Setting range	Initial value	Unit	Accessibility	PDO assignment	Change attribute	Retentive
UDINT	0 to 0xFFFFFFFF	-	-	RW	No	PREOP	Yes
SubIndex 8		Mapping entry 8					
Variable type	Setting range	Initial value	Unit	Accessibility	PDO assignment	Change attribute	Retentive
UDINT	0 to 0xFFFFFFFF	-	-	RW	No	PREOP	Yes
SubIndex 9		Mapping entry 9					
Variable type	Setting range	Initial value	Unit	Accessibility	PDO assignment	Change attribute	Retentive
UDINT	0 to 0xFFFFFFFF	-	-	RW	No	PREOP	Yes
SubIndex 10		Mapping entry 10					

Variable type	Setting range	Initial value	Unit	Accessibility	PDO assignment	Change attribute	Retentive
UDINT	0 to 0xFFFFFFFF	-	-	RW	No	PREOP	Yes

Refer to the description of 0x1600.

0x1C00 Sync Manager Communication Type							
SubIndex 0		Number of entries					
Variable type	Setting range	Initial value	Unit	Accessibility	PDO assignment	Change attribute	Retentive
USINT	-	4	-	RO	No	-	No
SubIndex 1		Communication type SM0					
Variable type	Setting range	Initial value	Unit	Accessibility	PDO assignment	Change attribute	Retentive
USINT	-	1	-	RO	No	-	No
SubIndex 2		Communication type SM1					
Variable type	Setting range	Initial value	Unit	Accessibility	PDO assignment	Change attribute	Retentive
USINT	-	2	-	RO	No	-	No
SubIndex 3		Communication type SM2					
Variable type	Setting range	Initial value	Unit	Accessibility	PDO assignment	Change attribute	Retentive
USINT	-	3	-	RO	No	-	No
SubIndex 4		Communication type SM3					
Variable type	Setting range	Initial value	Unit	Accessibility	PDO assignment	Change attribute	Retentive
USINT	-	4	-	RO	No	-	No

It represents the Sync Manager Communication Type assigned by default.

0x1C10 Sync Manager 0 PDO Assignment							
Variable type	Setting range	Initial value	Unit	Accessibility	PDO assignment	Change attribute	Retentive
USINT	-	0	-	RO	No	-	No

0x1C11 Sync Manager 1 PDO Assignment							
Variable type	Setting range	Initial value	Unit	Accessibility	PDO assignment	Change attribute	Retentive
USINT	-	0	-	RO	No	-	No

0x1C12		Sync Manager 2 PDO Assignment					
SubIndex 0		Number of entries					
Variable type	Setting range	Initial value	Unit	Accessibility	PDO assignment	Change attribute	Retentive
USINT	-	1	-	RW	No	-	No
SubIndex 1		Index of object assigned to PDO					
Variable type	Setting range	Initial value	Unit	Accessibility	PDO assignment	Change attribute	Retentive
UINT	0x1600 to 0x1603	0x1601	-	RW	No	PREOP	No

0x1C13		Sync Manager 3 PDO Assignment					
SubIndex 0		Number of entries					
Variable type	Setting range	Initial value	Unit	Accessibility	PDO assignment	Change attribute	Retentive
USINT	-	1	-	RW	No	-	No
SubIndex 1		Index of object assigned to PDO					
Variable type	Setting range	Initial value	Unit	Accessibility	PDO assignment	Change attribute	Retentive
UINT	0x1A00 to 0x1A03	0x1A01	-	RW	No	PREOP	No

0x1C32		Output Sync Manager Parameter					
SubIndex 0		Number of entries					
Variable type	Setting range	Initial value	Unit	Accessibility	PDO assignment	Change attribute	Retentive
USINT	-	32	-	RO	No	-	No
SubIndex 1		Sync mode					
Variable type	Setting range	Initial value	Unit	Accessibility	PDO assignment	Change attribute	Retentive
UINT	-	-	-	RO	No	-	No
SubIndex 2		Cycle time					
Variable type	Setting range	Initial value	Unit	Accessibility	PDO assignment	Change attribute	Retentive
UDINT	-	-	ns	RO	No	-	No

SubIndex 3		Shift time					
Variable type	Setting range	Initial value	Unit	Accessibility	PDO assignment	Change attribute	Retentive
UDINT	-	0	ns	RO	No	-	No
SubIndex 4		Sync modes supported					
Variable type	Setting range	Initial value	Unit	Accessibility	PDO assignment	Change attribute	Retentive
UINT	-	0x4007	-	RO	No	-	No
SubIndex 5		Minimum cycle time					
Variable type	Setting range	Initial value	Unit	Accessibility	PDO assignment	Change attribute	Retentive
UDINT	-	250000	ns	RO	No	-	No
SubIndex 6		Calc and copy time					
Variable type	Setting range	Initial value	Unit	Accessibility	PDO assignment	Change attribute	Retentive
UDINT	-	0	ns	RO	No	-	No
SubIndex 9		Delay time					
Variable type	Setting range	Initial value	Unit	Accessibility	PDO assignment	Change attribute	Retentive
UDINT	-	0	ns	RO	No	-	No
SubIndex 10		Sync0 time					
Variable type	Setting range	Initial value	Unit	Accessibility	PDO assignment	Change attribute	Retentive
UDINT	-	0	ns	RO	No	-	No
SubIndex 11		Cycle exceeded counter					
Variable type	Setting range	Initial value	Unit	Accessibility	PDO assignment	Change attribute	Retentive
UDINT	-	0	-	RO	No	-	No
SubIndex 12		SM event missed counter					
Variable type	Setting range	Initial value	Unit	Accessibility	PDO assignment	Change attribute	Retentive
UDINT	-	0	-	RO	No	-	No
SubIndex 13		Shift too short counter					
Variable type	Setting range	Initial value	Unit	Accessibility	PDO assignment	Change attribute	Retentive
UDINT	-	0	-	RO	No	-	No
SubIndex 32		Sync error					
Variable type	Setting range	Initial value	Unit	Accessibility	PDO assignment	Change attribute	Retentive

type				ty	assignment	attribute	e
BOOL	-	0	-	RO	No	-	No

0x1C33	Input Sync Manager Parameter						
SubIndex 0		Number of entries					
Variable type	Setting range	Initial value	Unit	Accessibility	PDO assignment	Change attribute	Retentive
USINT	-	32	-	RO	No	-	No
SubIndex 1		Sync mode					
Variable type	Setting range	Initial value	Unit	Accessibility	PDO assignment	Change attribute	Retentive
UINT	-	-	-	RO	No	-	No
SubIndex 2		Cycle time					
Variable type	Setting range	Initial value	Unit	Accessibility	PDO assignment	Change attribute	Retentive
UDINT	-	-	ns	RO	No	-	No
SubIndex 3		Shift time					
Variable type	Setting range	Initial value	Unit	Accessibility	PDO assignment	Change attribute	Retentive
UDINT	-	0	ns	RO	No	-	No
SubIndex 4		Sync modes supported					
Variable type	Setting range	Initial value	Unit	Accessibility	PDO assignment	Change attribute	Retentive
UINT	-	0x4007	-	RO	No	-	No
SubIndex 5		Minimum cycle time					
Variable type	Setting range	Initial value	Unit	Accessibility	PDO assignment	Change attribute	Retentive
UDINT	-	250000	ns	RO	No	-	No
SubIndex 6		Calc and copy time					
Variable type	Setting range	Initial value	Unit	Accessibility	PDO assignment	Change attribute	Retentive
UDINT	-	0	ns	RO	No	-	No
SubIndex 9		Delay time					
Variable type	Setting range	Initial value	Unit	Accessibility	PDO assignment	Change attribute	Retentive
UDINT	-	0	ns	RO	No	-	No
SubIndex 10		Sync0 time					



Variable type	Setting range	Initial value	Unit	Accessibility	PDO assignment	Change attribute	Retentive
UDINT	-	0	ns	RO	No	-	No
Subindex 11		Cycle exceeded counter					
Variable type	Setting range	Initial value	Unit	Accessibility	PDO assignment	Change attribute	Retentive
UDINT	-	0	-	RO	No	-	No
SubIndex 12		SM event missed counter					
Variable type	Setting range	Initial value	Unit	Accessibility	PDO assignment	Change attribute	Retentive
UDINT	-	0	-	RO	No	-	No
SubIndex 13		Shift too short counter					
Variable type	Setting range	Initial value	Unit	Accessibility	PDO assignment	Change attribute	Retentive
UDINT	-	0	-	RO	No	-	No
SubIndex 32		Sync error					
Variable type	Setting range	Initial value	Unit	Accessibility	PDO assignment	Change attribute	Retentive
BOOL	-	0	-	RO	No	-	No

## 11.3 Manufacturer Specific Objects

### ● Basic Setting(0x2000~ )

0x2000	Motor ID						ALL
Variable type	Setting range	Initial value	Unit	Accessibility	PDO assignment	Change attribute	Retentive
UINT	1 to 9999	13	-	RW	No	Power cycling	Yes

Set the motor ID. This is automatically set for the serial encoders provided by LS Mecapion. You can check the automatically set IDs. You can check the motor ID on the motor nameplate.

E.g. The motor ID is 137 on the nameplate attached to the motor shown in the figure below:



0x2001	Encoder Type						ALL
Variable type	Setting range	Initial value	Unit	Accessi bility	PDO assignme nt	Change attribute	Rete ntive
UINT	0 to 99	1	-	RW	No	Power cycling	Yes

Set the encoder type. You have to set it correctly by referencing the table below.

The letter A tacked on at the end of the encoder type is set when it is connected to the encoder A port. The letter B is set when it is connected to the encoder B port.

예)1) Setting when Quadrature encoder is connected to the encoder A port: 1

예)2) Setting when BiSS Serial encoder is connected to the encoder B port: 4

Settings	Encoder type
0	Not selected
1	Quadrature, Port A
2	Quadrature, Port B
3	BiSS, Port A
4	BiSS, Port B
5	Sinusoidal sin/cos, Port B
6	Analog hall only, Port B
7	SSI, Port A
8	SSI, Port B
9	Panasonic(incremental/absolute), Port A
10	Panasonic(incremental/absolute), Port B
11	Tamagawa, Port A
12	Tamagawa, Port B
13	EnDat(2.1/2.2), Port A
14	EnDat(2.1/2.2), Port B

15	Resolver(R optional only), Port B
16	Sinusoidal to BiSS, Port A
17	Sinusoidal to BiSS, Port B
18	Analog Hall to BiSS, Port A
19	Analog Hall to BiSS, Port B
20	Nikon, Port A (TBD)
21	Nikon, Port B (TBD)
22	Halls, Port A (TBD)

You can check the encoder type on the nameplate attached to the motor.

Please refer to the product type of the servo motor.

0x2002	Encoder Pulse per Revolution						ALL
Variable type	Setting range	Initial value	Unit	Accessi bility	PDO assignme nt	Change attribute	Rete ntive
UDINT	0 to 1073741824	10000	pulse	RW	No	Power cycling	Yes

Set the encoder resolution in pulse (count) based on a multiple of 4. Generally, you can check the encoder resolution on the nameplate. (Refer to the description of 0x2000.)

E.g. Setting for each encoder marking on the motor product nameplate

Inc. 3000p/r: 12000

Serial 20-bit: 1048576

Serial 16/19-bit: 524288

0x2003	Node ID						ALL
Variable type	Setting range	Initial value	Unit	Accessi bility	PDO assignme nt	Change attribute	Rete ntive
UINT	0 to 127	-	-	RO	No	-	No

Display the node ID configured for the node setting switch of the drive. The value of the node setting switch is read just once when the power is turned on. Any set value modified subsequently will be in effect only when the power is turned off and then turned on again.

E.g. When the node ID is set to 26 (0x1A)

Address(1~7), Factory purpose(8)

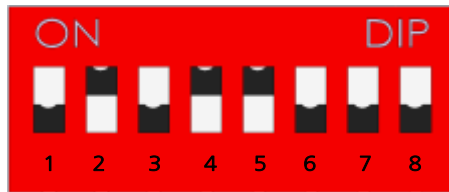

0x2004	Rotation Direction Select						ALL
Variable type	Setting range	Initial value	Unit	Accessi bility	PDO assignme nt	Change attribute	Rete ntive
UINT	0 to 1	0	-	RW	No	Power cycling	Yes

Set the rotation direction of the motor. You can change the rotation direction with this setting when the direction is changed between positive and negative relative to the user in the final apparatus section.

Setting s	Description
0	With a positive command, the motor rotates counterclockwise. Then, the position feedback value increases.
1	With a positive command, the motor rotates clockwise. Then, the position feedback value increases.

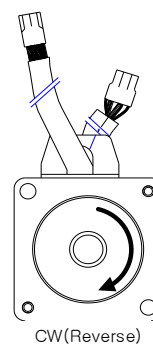
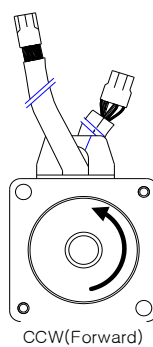

0x2005	Absolute Encoder Configuration						ALL
Variable type	Setting range	Initial value	Unit	Accessi bility	PDO assignme nt	Change attribute	Rete ntive
UINT	0 to 1	1	-	RW	No	Power cycling	Yes

Set the usage of the absolute encoder.

Settings	Description
0	Uses the absolute encoder as the absolute encoder. Uses the multi-turn data.
1	Uses the absolute encoder as the incremental encoder. Does not use the multi-turn data. Does not display any battery-related alarms/warnings.

0x2008	7SEG Display Selection						ALL
Variable type	Setting range	Initial value	Unit	Accessibility	PDO assignment	Change attribute	Retentive
UINT	0 to 100	0	-	RW	Yes	Always	Yes

This specifies items to display in the 7SEG window of the drive CM program.

Settings	Displayed item	Unit	Description
0	Operation status	-	
1	Speed feedback	rpm, mm/s	
2	Speed command	rpm, mm/s	
3	Torque feedback	0.1%	
4	Torque command	0.1%	
5	Accumulated operation overload	0.1%	
6	DC link voltage	V	
7	Reserved		
8	Mechanical angle	0.1deg	
9	Electrical angle	0.1deg	
10	Inertia ratio	%	
11	Drive temperature 1	°C	Temperature near the drive power element
12	Drive temperature 2	°C	Internal temperature of drive
13	Encoder temperature 1	°C	Internal temperature of encoder
14	Node ID	-	
15	Instantaneous maximum load factor	0.1%	Instantaneous maximum load factor for 15 seconds
16	Root Mean Square (RMS) load factor	0.1%	Root Mean Square (RMS) load factor for 15 seconds

0x200F	Overload Check Base						ALL
Variable type	Setting range	Initial value	Unit	Accessi bility	PDO assignme nt	Change attribute	Rete ntive
UINT	10 to 120	100	%	RW	No	Always	Yes

This indicates the load factor at which operation overload starts to accumulate. When this is set to a value that is 100 or less, operation overload will start to accumulate earlier at the set load factor resulting in the operation overload alarm (AL-21) being triggered early. If the heat radiation condition of the drive is poor, configure the setting to 100% or less to trigger an overload alarm earlier.

0x2010	Overload Warning Level						ALL
Variable type	Setting range	Initial value	Unit	Accessi bility	PDO assignme nt	Change attribute	Rete ntive
UINT	10 to 100	50	%	RW	No	Always	Yes

This specifies the output level of the accumulated operation overload warning (W10). When the accumulated operation overload rate (0x2603) reaches the set value, a warning will be output. With this setting, you can identify the time when you need to take appropriate action before an accumulated operation overload alarm occurs.

0x2011	PWM Off Delay Time						ALL
Variable type	Setting range	Initial value	Unit	Accessi bility	PDO assignme nt	Change attribute	Rete ntive
UINT	0 to 1000	10	ms	RW	No	Always	Yes

This specifies the delay time until the PWM actually turns off after running the servo off command. When using a motor with a brake installed on the vertical axis, you can output the brake signal first, and then turn off the PWM after this set time, in order to prevent it from running down along the axis.

0x2013	Emergency Stop Configuration						ALL
--------	------------------------------	--	--	--	--	--	-----

Variable type	Setting range	Initial value	Unit	Accessibility	PDO assignment	Change attribute	Retentive
UINT	0 to 1	1	-	RW	No	Always	Yes

This specifies the method to do an emergency stop (when entering POT, NOT, or ESTOP) on the drive. In torque control mode, the deceleration to stop mode using the emergency stop torque is not applied.

Settings	Description
0	Maintain torque command at 0 after the pre-run has stopped.
1	Decelerates to a stop using the emergency stop torque (0x2113).

0x2014	Warning Mask Configuration							ALL
Variable type	Setting range	Initial value	Unit	Accessibility	PDO assignment	Change attribute	Retentive	
UINT	0 to FFFF <sub>hex</sub>	0	-	RW	Yes	Always	Yes	

When a warning occurs, the warning masked by this setting will not be triggered.

Bit	Warning code	Warning name
1	W02	Low voltage of encoder battery
2	W04	Software position limit
3	W08	Reserved
4	W10	Operation overload warning
5	W20	Abnormal combination of drive and motor
6	W40	Low voltage warning
7	W80	Emergency signal input
14	AL-34	Alarm mask for encoder Z-phase loss

0x2015	U Phase Current Offset							ALL
Variable type	Setting range	Initial value	Unit	Accessibility	PDO assignment	Change attribute	Retentive	

INT	-1000 to 1000	0	0.1%	RW	No	Always	Yes
-----	---------------	---	------	----	----	--------	-----

Manually set the U-phase current offset. The configured offset value is subtracted from the measured current value, and then applied as the actual current value. Do not manually set the offset if you do not know the exact setting value. You can check the automatically-tuned value if you tune the current offset with the procedure function. (Refer to the description of 0x2700.)

Variable type	Setting range	Initial value	Unit	Accessi- bility	PDO assignme- nt	Change attribute	Rete- ntive
0x2016	V Phase Current Offset						ALL
INT	-1000 to 1000	0	0.1%	RW	No	Always	Yes

Manually set the V-phase current offset. The configured offset value is subtracted from the measured current value, and then applied as the actual current value. Do not manually set the offset if you do not know the exact setting value. You can check the automatically-tuned value if you tune the current offset with the procedure function. (Refer to the description of 0x2700.)

Variable type	Setting range	Initial value	Unit	Accessi- bility	PDO assignme- nt	Change attribute	Rete- ntive
0x2017	W Phase Current Offset						ALL
INT	-1000 to 1000	0	0.1%	RW	No	Always	Yes

Manually set the W-phase current offset. The configured offset value is subtracted from the measured current value, and then applied as the actual current value. Do not manually set the offset if you do not know the exact setting value. You can check the automatically-tuned value if you tune the current offset with the procedure function. (Refer to the description of 0x2700.)

This parameter is not used in the Phoenix Series products since the W-phase current is not separately measured.

Variable type	Setting range	Initial value	Unit	Accessi- bility	PDO assignme- nt	Change attribute	Rete- ntive
0x2018	Magnetic Pole Pitch						ALL
UINT	1 to 65535	2400	.01mm	RW	No	Power cycling	Yes



This specifies the pitch between the magnetic poles of the linear motor. The pole pitch refers to the distance between the north poles or between the south poles of a magnet, corresponding to 360° of an electrical angle.

0x2019	Linear Scale Resolution						ALL
Variable type	Setting range	Initial value	Unit	Accessi bility	PDO assignme nt	Change attribute	Rete ntive
UINT	1 to 65535	1000	nm	RW	No	Power cycling	Yes

Set Linear Scale Resolution in nm. For a linear scale with a resolution of 1 um, set it to 1000 (= 1 um / 1 nm).

0x201A	Commutation Method						ALL
Variable type	Setting range	Initial value	Unit	Accessi bility	PDO assignme nt	Change attribute	Rete ntive
UINT	0 to 2	0	-	RW	No	Power cycling	Yes

Select a commutation method to get information on the initial angle of the motor.

Settings	Description
0	Not necessary for separate commutation. Or, carry out commutation using a hall sensor.
1	Carry out commutation when the servo is turned on for the first time.
2	Reserved

0x201B	Commutation Current						ALL
Variable type	Setting range	Initial value	Unit	Accessi bility	PDO assignme nt	Change attribute	Rete ntive
UINT	0 to 1000	500	0.1%	RW	No	Always	Yes

Select the commutation current to get information on the initial angle of the motor.

0x201C	Commutation Time						ALL
Variable type	Setting range	Initial value	Unit	Accessi- bility	PDO assignme- nt	Change attribute	Rete- ntive
UINT	500 to 5000	1000	ms	RW	No	Always	Yes

Select the commutation time to get information on the initial angle of the motor.

0x201D	Grating Period of Sinusoidal Encoder						ALL
Variable type	Setting range	Initial value	Unit	Accessi- bility	PDO assignme- nt	Change attribute	Rete- ntive
UINT	1 to 65535	40	um	RW	No	Power cycling	Yes

Specify the grid size of the sine wave encoder.

0x201E	Homing Done Behaviour						ALL
Variable type	Setting range	Initial value	Unit	Accessi- bility	PDO assignme- nt	Change attribute	Rete- ntive
UINT	0 to 1	0	-	RW	No	Always	Yes

This specifies whether to move to the zero position by Home Offset[0x607C] after homing is completed.

Settings	Description
0	After homing with Homing Method [0x6098] is completed, the motor does not rotate, and the Home Offset [0x607C] value changes to the zero position.
1	After homing with Homing Method [0x6098] is completed, the motor rotates as much as the amount of Home Offset [0x607C] and the zero position becomes 0.

0x201F	Velocity Function Select						ALL
Variable type	Setting range	Initial value	Unit	Accessi- bility	PDO assignme- nt	Change attribute	Rete- ntive

					nt		
UINT	0 to 2	0	-	RW	No	Always	Yes

If the encoder type is Quadrature, select the method to calculate the feedback speed.

Settings	Description
0	MT Method + Speed Observer
1	MT Method
2	M Method

0x2020	Motor Hall Phase Config						ALL
Variable type	Setting range	Initial value	Unit	Accessi bility	PDO assignme nt	Change attribute	Rete ntive
UINT	0 to 65535	0	-	RW	No	Power cycling	Yes

For a third-party motor, check the motor wiring and hall sensor wiring and configure the motor rotation direction, hall sensor polarity, and hall sensor UVW sequence.

Bit	Description
0	Motor rotation direction setting (Exclusive OR is applied between this value and the 0x2004 setting)
1~7	Reserved
8	Reversal of hall U polarity
9	Reversal of hall V polarity
10	Reversal of hall W polarity
11	Reserved
12	Replace hall U and hall V
13	Replace hall V and hall W
14	Replace hall W and hall U
15	Reserved

0x2021	Load Encoder Type						ALL
Variable type	Setting range	Initial value	Unit	Acces sibility	PDO assign ment	Change attribute	Rete ntiv e

UINT	0-100	0	-	RW	No	Power cycling	Yes
------	-------	---	---	----	----	---------------	-----

This sets the second encoder, which is attached to the load side. The same setting applies to the motor-side encoder type.

Settings	Encoder type
0	Not selected
1	Quadrature, Port A
2	Quadrature, Port B
3	BiSS, Port A
4	BiSS, Port B
5	Sinusoidal sin/cos, Port B
6	Analog hall only, Port B
7	SSI, Port A
8	SSI, Port B
9	Panasonic(incremental/absolute), Port A
10	Panasonic(incremental/absolute), Port B
11	Tamagawa, Port A
12	Tamagawa, Port B
13	EnDat(2.1/2.2), Port A
14	EnDat(2.1/2.2), Port B
15	Resolver(R optional only), Port B
16	Sinusoidal to BiSS, Port A
17	Sinusoidal to BiSS, Port B
18	Analog Hall to BiSS, Port A
19	Analog Hall to BiSS, Port B
20	Nikon, Port A (TBD)
21	Nikon, Port B (TBD)
22	Halls, Port A (TBD)

0x2022	Reverse Load Encoder Direction						ALL
Variable	Setting	Initial	Unit	Accessibility	PDO	Change	Retentive

type	range	value			assignment	attribute	
UINT	0 to 1	0	-	RW	No	Power cycling	Yes

Set the direction of the 2nd encoder on the load side.

Settings	Setting details
0	Increase position value in the CCW direction.
1	Increase position value in the CW direction.

Variable type	Setting range	Initial value	Unit	Accessi- bility	PDO assignme- nt	Change attribute	Reten- tive
0x2023	Full-Closed Control Mode						ALL
UINT	0 to 2	0	-	RW	No	Power cycling	Yes

Set the full-closed control mode.

Settings	Setting details
0	Semi-Closed Control (controls using only the motor-side encoder, default value)
1	Full-Closed Control (controls using the load-side encoder)
2	Dual-Feedback Control (controls using both the motor-side and load-side encoders)

Variable type	Setting range	Initial value	Unit	Accessi- bility	PDO assignme- nt	Change attribute	Reten- tive
x2024	Dual Feedback Conversion Time Constant						ALL
UINT	0 to 1000	0	0.1ms	RW	No	Servo off	Yes

In the case of dual-feedback control that refers to an external encoder, the filter time constant is set to 0.1 ms at the time when the mode switches between semi-closed control and full-closed control.

As the setting value gets close to 0 ms, it refers to the external encoder more. As it gets close to 100 ms, it refers to the motor-side encoder more. It minimizes the vibrations that are generated due to mechanical characteristics or external factors to shorten the adjustment time.

1). Examples of setting the dual-feedback filter time constant

Shortens the time for position adjustment  
 Weighted value of semi-closed control increases.

Increase the size of the dual feedback filter.  
 Weighted value of the motor-side encoder increases.

Decrease the size of the dual feedback filter.  
 Weighted value of the load-side encoder

Vibrations suppressed  
 Weighted value of full-closed control increases.

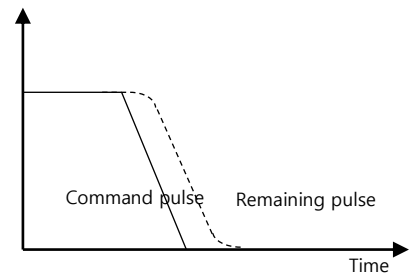
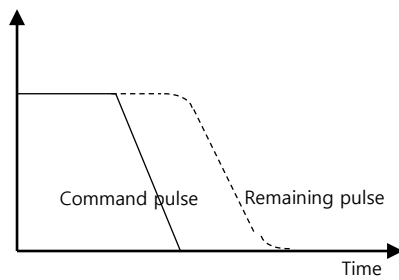

0x2025	Numerator of Load Encoder Scale						ALL
Variable type	Setting range	Initial value	Unit	Accessi- bility	PDO assignme- nt	Change attribute	Reten- tive
UINT	0 to 2147483647	1	-	RW	No	Power cycling	Yes

0x2026	Denominator of Load Encoder Scale						ALL
Variable type	Setting range	Initial value	Unit	Accessi- bility	PDO assignme- nt	Change attribute	Reten- tive
UINT	0 to 2147483647	1	-	RW	No	Power cycling	Yes

Set the numerator/denominator scale for the load encoder to ensure the same scale with the motor encoder,

Examples of scale setting methods

1. Direct connection structure	This sets the scale so the number of external encoder pulses can be calculated based on the number of encoder pulses per motor rotation.
Motor encoder specifications	524288[pulse/rev]
Amount of load movement/revolution	12000[pulse/rev]
Gear ratio setting	<p>Number of external encoder pulses x (numerator / denominator) = Number of motor encoder pulses</p> $12000(\text{Number of external encoder pulses}) \times \frac{524288 (\text{Numerator})}{12000 (\text{Denominator})} = 524288(\text{Number of motor encoder pulses})$

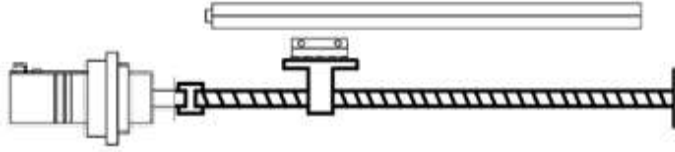
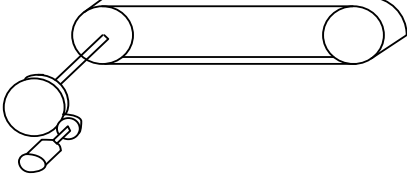
<p>2. Gearbox structure</p>	 <ul style="list-style-type: none"> <li>- Reduction gear ratio: 1/10</li> <li>- Ball screw lead: 20 mm</li> <li>- Linear encoder (external encoder): 4 um</li> </ul> <p>If the 1/10-ratio gearbox is installed on the motor, the gearbox shaft rotates 1/10 turns per motor rotation. So, the scale is calculated by multiplying the deceleration ratio with the number of external encoder pulses.</p>
<p>Motor encoder specifications</p>	<p>524288[pulse/rev]</p>
<p>Amount of load movement/revolution</p>	<p>The movement of the table per rotation of the servo motor equipped with a 1/10 gearbox is  <math>(1/10) * 20 \text{ mm} = 2 \text{ mm}</math>. The number of external encoder pulses is calculated as <math>2 \text{ mm} / 4 \text{ um} = 500 \text{ pulses}</math>.</p>
<p>Gear ratio setting</p>	<p>Number of external encoder pulses x (numerator / denominator) = Number of motor encoder pulses</p> $500(\text{Number of external encoder pulses}) \times \frac{524288 (\text{Numerator})}{500 (\text{Denominator})} = 524288(\text{Number of motor encoder pulses})$
<p>3. Belt-pulley structure</p>	 <ul style="list-style-type: none"> <li>- Motor-side pulley diameter: 30 mm</li> <li>- Rotary-side pulley diameter: 20 mm</li> <li>- External encoder resolution: 20000 pulse/rev</li> </ul> <p>In the case of a gear and belt-pulley system, the final gear ratio is calculated and the gear ratio is multiplied by the number of external encoder pulses to produce the scale.</p>
<p>Motor encoder specifications</p>	<p>524288[pulse/rev]</p>
<p>Amount of load movement/revolution</p>	<p>The external encoder rotates at a ratio of 30 / 20 per servo motor rotation. The number of pulses for the external encoder is calculated as <math>20000 \times (3/2) = 30000 \text{ pulses}</math>.</p>



Gear ratio setting	<p>Number of external encoder pulses x (numerator / denominator) = Number of motor encoder pulses</p> $30000(\text{Number of external encoder pulses}) \times \frac{524288 \text{ (Numerator)}}{30000 \text{ (Denominator)}} = 524288(\text{Number of motor encoder pulses})$
--------------------	---

0x2027	Load Encoder Following Error Window						ALL
Variable type	Setting range	Initial value	Unit	Accessi- bility	PDO assignme- nt	Change attribute	Reten- tive
UDINT	0 to 2147483647	100000	pulse	RW	No	Always	Yes

0x2028	Load Encoder Following Error Reset						ALL
Variable type	Setting range	Initial value	Unit	Accessi- bility	PDO assignme- nt	Change attribute	Reten- tive
UDINT	0 to 10000	10	Rev	RW	No	Always	Yes

This sets the position error level for the external encoder and the reset range for the error position value.

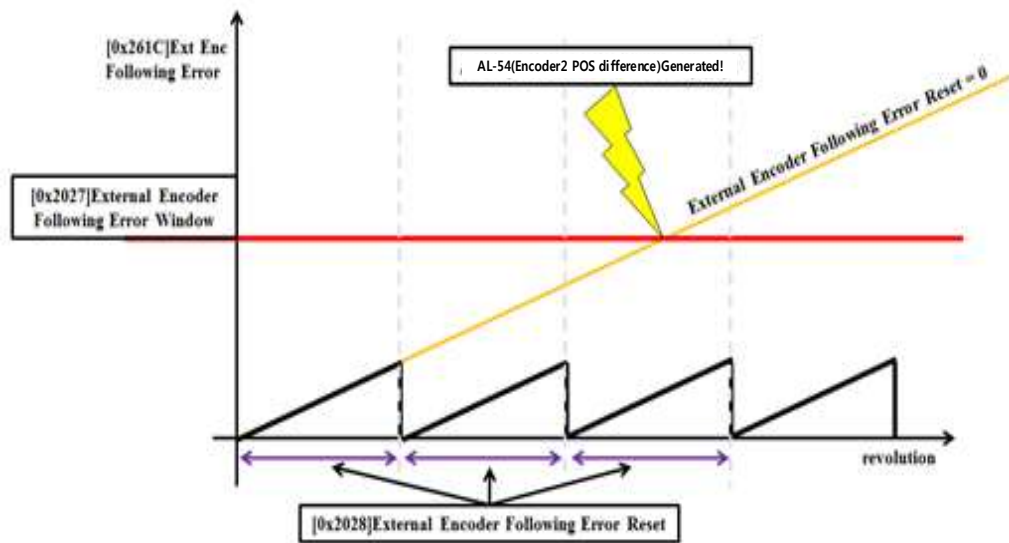

Based on the 0x2027 (External Encoder Following Error Window) settings, the AL-54 (Encoder2 POS difference) level can be adjusted. For of a system where a slip occurs, the 0x2028 (External Encoder Following Error Reset) settings can be used to set the normal slip range for the following error value.

0x202A	Motor Encoder Configuration						ALL
Variable	Setting range	Initial	Unit	Accessi	PDO	Change	Reten

type		value		bility	assignme nt	attribute	tive
UDINT	0x0 to 0xFFFFFFFF	0x0	-	RW	No	Power cycling	Yes

This sets the first encoder, which is attached to the motor. The settings below change depending on the setting of the encoder type 1. Do not set the reserved bit.

Bit	Description (if encoder type is quadrature)																								
3~0	Debounce filter settings																								
	<table border="1"> <thead> <tr> <th>Settings</th> <th>Cutoff Frequency</th> </tr> </thead> <tbody> <tr> <td>0</td> <td>No Filter</td> </tr> <tr> <td>1</td> <td>5.000MHz</td> </tr> <tr> <td>2</td> <td>3.330MHz</td> </tr> <tr> <td>3</td> <td>2.500MHz</td> </tr> <tr> <td>4</td> <td>2.000MHz</td> </tr> <tr> <td>5</td> <td>1.667MHz</td> </tr> <tr> <td>6</td> <td>1.429MHz</td> </tr> <tr> <td>7</td> <td>1.250MHz</td> </tr> <tr> <td>8</td> <td>1.000MHz</td> </tr> <tr> <td>9</td> <td>0.833MHz</td> </tr> <tr> <td>10</td> <td>0.714MHz</td> </tr> </tbody> </table>	Settings	Cutoff Frequency	0	No Filter	1	5.000MHz	2	3.330MHz	3	2.500MHz	4	2.000MHz	5	1.667MHz	6	1.429MHz	7	1.250MHz	8	1.000MHz	9	0.833MHz	10	0.714MHz
	Settings	Cutoff Frequency																							
	0	No Filter																							
	1	5.000MHz																							
	2	3.330MHz																							
	3	2.500MHz																							
	4	2.000MHz																							
	5	1.667MHz																							
	6	1.429MHz																							
	7	1.250MHz																							
	8	1.000MHz																							
9	0.833MHz																								
10	0.714MHz																								
31~4	Reserved																								

Bit	Description (if encoder type is BiSS)
5~0	Number of bits for single-turn data
12~8	Number of bits for multi-turn data
16	Mode B setting (0: mode C, 1: mode B)
20	Error and warning bit polarity setting (0: active high, 1: active low)
21	Position of status bit (0: behind the position data, 1: in front of the position data, reserved)
22	Position relationship between error and warning bit (0: error at the front, 1: error is at the back)
26~24	Alignment bit number setting
28	reserved
30	Baud rate setting (reserved)

Setting example:

Bit	BiSS-B single-turn	BiSS-C multi-turn	RSA singleturn
5~0	19	19	22
12~8	0	16	0
16	1	0	0
20	0	0	0
21	0	0	0
22	0	0	0
26~24	2	2	0
28	-	-	-
30	-	-	-
Setting value (hex)	0x02010013	0x02001013	0x00000016

Bit	Description (if encoder type is sinusoidal)
3~0	Refer to the debounce filter settings and quad setting parameters.
31~4	Reserved

Bit	Description (if encoder type is SSI)
0-7	Number of data bits
8-15	Number of bits for rotary multi-turn data (For a linear encoder, the setting value is irrelevant.)
16	Whether to ignore the first bit (0: one start bit, 1: two start bits)
17	Coding(0:binary, 1:gray)
20-23	Number of align bits
24-27	Clock rate (0:10Mhz, 1:5Mhz, 2:2.5Mhz, 3:1.25Mhz, 4:625Khz, 5:312.5Khz, 6:156.25Khz, 7:78.125Khz)
28	Whether error bit exists (0: No, 1: Yes)
29	Error bit logic(0:active high, 1:active low)
31~30	reserved

Setting example:

Bit	Description (if encoder type is SSI)
5~0	13
12~8	10
16	0(one start bit)
17	0

18	0
19	-
22~20	2 align bit
23	0
27-24	2
28	0
29	0
31~30	-

Bit	Description (if encoder type is Panasonic or Tamagawa)
5~0	Number of single-turn data bits (number of entire data bits for a linear encoder)
12~8	Number of multi-turn data bits (0 or 16. Ignored in the case of a linear encoder)
19~16	Number of dummy LSB bits
22~20	Number of continuous CRC errors (reserved)
27~24	reserved
28	Baud rate setting (reserved)
30	Regards battery error as a warning (reserved)
31	Use the setting from encoder pulse per revolution (0x2002)

## Setting Example

Bit	Panasonic absolute	Panasonic incremental
5~0	17	20
12~8	16	0
19~16	0	0
22~20	-	-
27~24	-	-
28	-	-
30	0	0

Bit	Description (if encoder type is EnDat)
5~0	Number of bits for single-turn data
12~8	Number of bits for multi-turn data

17~16	reserved
18	EnDat command style(0:EnDat2.2, 1:EnDat2.1)
23~20	Number of dummy LSB bits

Bit	Description (if encoder type is resolver)
3~0	Number of resolver cycles per revolution
7~4	Exciting frequency
31~4	Reserved

0x202B	Load Encoder Configuration						ALL
Variable type	Setting range	Initial value	Unit	Accessi- bility	PDO assignme- nt	Change attribute	Rete- ntive
UDINT	0x0 to 0xFFFFFFFF	0	-	RW	No	Power cycling	Yes

This sets the second encoder, which is attached to the load side.

The setting method is the same as the motor-side encoder setting [0x202A].

0x202C	Lines per Revolution of Sinusoidal Encoder						ALL
Variable type	Setting range	Initial value	Unit	Accessi- bility	PDO assignme- nt	Change attribute	Rete- ntive
UDINT	0-65535	1000	-	RW	No	Power cycling	Yes

This sets the CPR or line count (number of grids per revolution) on a sine wave encoder.

0x202D	FIR Filter Window of Speed Feedback						ALL
Variable type	Setting range	Initial value	Unit	Accessi- bility	PDO assignme- nt	Change attribute	Rete- ntive
UDINT	0 to 8	0	-	RW	No	Power cycling	Yes

This sets the degree of FIR filter for speed feedback.

In order to apply a FIR filter on a speed feedback signal, set the value to 2 or more. In this case, the speed feedback filter time constant [0x201B] does not apply. In order to use the speed feedback filter time constant, set the value to 0.

0x2030	PWM Frequency						ALL
Variable type	Setting range	Initial value	Unit	Accessibility	PDO assignment	Change attribute	Retentive
UINT	0 to 2	0	-	RW	No	Power cycling	Yes

This sets the PWM frequency for the drive. The PWM frequency setting is available in multiples of 16 kHz, which is the current control cycle for the drive. You can set up to 48 kHz, and the overload condition may change depending on the setting.

Settings	Description
0	16Khz
1	32Khz
2	48Khz

0x2031	Operation Time at Peak Current						ALL
Variable type	Setting range	Initial value	Unit	Accessibility	PDO assignment	Change attribute	Retentive
UINT	1 to 65535	1000	ms	RW	No	Power cycling	Yes

This sets the maximum operation time at the maximum motor current. The setting protects the motor with an I<sup>2</sup>T algorithm, so it should be set correctly.

0x2032	Under-Voltage Fault Level						ALL
Variable type	Setting range	Initial value	Unit	Accessibility	PDO assignment	Change attribute	Retentive
UINT	20 to 90	20	V	RW	No	Power cycling	Yes

This sets the level of the insufficient voltage alarm (AL-40) for the drive. If the relationship between the insufficient voltage and overvoltage alarm level is not set correctly, the insufficient voltage is set to 20 V and overvoltage is set to 90 V.

0x2033 Over-Voltage Fault Level							
Variable type	Setting range	Initial value	Unit	Accessi- bility	PDO assignme- nt	Change attribute	Rete- ntive
UINT	20 to 90	90	V	RW	No	Power cycling	Yes

This sets the level of the overvoltage alarm (AL-41) for the drive. If the relationship between the insufficient voltage and overvoltage alarm level is not set correctly, the insufficient voltage is set to 20 V and overvoltage is set to 90 V.

0x2034 Motor Thermal Protection Enable							
Variable type	Setting range	Initial value	Unit	Accessi- bility	PDO assignme- nt	Change attribute	Rete- ntive
UINT	0 to 1	0	-	RW	No	Power cycling	Yes

This activates the protective function using the motor's thermal parameter (thermal resistance/capacitance).

Settings	Description
0	Disable
1	Enable

0x2035 Thermal Sensor 1 Fitted							
Variable type	Setting range	Initial value	Unit	Accessi- bility	PDO assignme- nt	Change attribute	Rete- ntive
UINT	0 to 1	0	-	RW	No	Power cycling	Yes

This sets whether to attach thermal sensor 1 (No. 10 pin of encoder A). If the parameter is set, it checks thermal sensor 1 to generate the motor overheat (AL-27) alarm.

Settings	Description
----------	-------------



0	Not attached
1	Attached

0x2036	Thermal Sensor 2 Fitted						ALL
Variable type	Setting range	Initial value	Unit	Accessi- bility	PDO assignme- nt	Change attribute	Rete- ntive
UINT	0 to 1	0	-	RW	No	Power cycling	Yes

This sets whether to attach thermal sensor 2 (No. 10 pin of encoder B). If the parameter is set, it checks thermal sensor 2 to generate the motor overheat (AL-27) alarm.

Settings	Description
0	Not attached
1	Attached

0x2037	Motor Brake Fitted						ALL
Variable type	Setting range	Initial value	Unit	Accessi- bility	PDO assignme- nt	Change attribute	Rete- ntive
UINT	0 to 1	0	-	RW	No	Power cycling	Yes

This sets whether to mount the motor brake. If the parameter is set, it operates the motor brake.

Settings	Description
0	Not attached
1	Attached

### Gain Adjustment(0x2100~ )

0x2100	Inertia Ratio						ALL
Variable type	Setting range	Initial value	Unit	Accessi- bility	PDO assignme- nt	Change attribute	Rete- ntive
UINT	0 to 3000	100	%	RW	No	Always	Yes

This specifies the ratio of the load inertia to the motor's rotor inertia as a percentage (%).

$$\text{Inertia ratio} = \text{Load inertia} / \text{Motor's rotor inertia} \times 100$$

The inertia/load ratio is an important control parameter for the operation of the servo. It is crucial to set the correct inertia ratio for optimal servo operation. You can estimate the inertia ratio by auto gain tuning. The ratio will be continuously estimated during operation if you carry out real-time gain tuning.

0x2101	Position Loop Gain 1						ALL
Variable type	Setting range	Initial value	Unit	Accessi- bility	PDO assignme- nt	Change attribute	Rete- ntive
UINT	1 to 500	50	1/s	RW	Yes	Always	Yes

This specifies the overall responsiveness of the position controller. The larger the setting, the responsiveness increases. Setting a value that is too large may cause vibrations depending on the load.

0x2102	Speed Loop Gain 1						ALL
Variable type	Setting range	Initial value	Unit	Accessi- bility	PDO assignme- nt	Change attribute	Rete- ntive
UINT	1 to 2000	75	Hz	RW	Yes	Always	Yes

This specifies the overall responsiveness of the speed controller. To increase the overall responsiveness of the system, you have to set a large speed loop gain as well, along with the position loop gain. Setting a value that is too large may cause vibrations depending on the load.

0x2103	Speed Loop Integral Time Constant 1						ALL
--------	-------------------------------------	--	--	--	--	--	-----

Variable type	Setting range	Initial value	Unit	Accessibility	PDO assignment	Change attribute	Retentive
UINT	1 to 1000	50	ms	RW	Yes	Always	Yes

This specifies the integral time constant of the speed controller. If you set a large value, errors will be reduced in a steady state (while stopped or driving at a constant speed), but vibrations may occur in a transient state (while accelerating or decelerating).

Variable type	Setting range	Initial value	Unit	Accessibility	PDO assignment	Change attribute	Retentive
0x2104	Torque Command Filter Time Constant 1						ALL
UINT	0 to 1000	5	0.1ms	RW	Yes	Always	Yes

This applies a low pass filter for the torque command. You can improve the stability of the system by setting an appropriate value to smooth out the torque command. If you set it too large, the delay for the torque command will be longer, reducing the system's responsiveness.

Variable type	Setting range	Initial value	Unit	Accessibility	PDO assignment	Change attribute	Retentive
0x2105	Position Loop Gain 2						ALL
UINT	1 to 500	30	1/s	RW	Yes	Always	Yes

This specifies the position loop gain used as gain group 2 for gain switching. For more information, refer to the description of the Position Loop Gain 1 (0x2101).

Variable type	Setting range	Initial value	Unit	Accessibility	PDO assignment	Change attribute	Retentive
0x2106	Speed Loop Gain 2						ALL
UINT	1 to 2000	50	Hz	RW	Yes	Always	Yes

This specifies the speed loop gain used as gain group 2 for gain switching. For more information, refer to the description of the Speed Loop Gain 1 (0x2102).

0x2107	Speed Loop Integral Time Constant 2						ALL
Variable type	Setting range	Initial value	Unit	Accessibility	PDO assignment	Change attribute	Retentive
UINT	1 to 1000	50	ms	RW	Yes	Always	Yes

This specifies the integral time constant of the speed loop used as gain group 2 for gain switching. For more information, refer to the description of the Speed Loop Integral Time Constant 1 (0x2103).

0x2108	Torque Command Filter Time Constant 2						ALL
Variable type	Setting range	Initial value	Unit	Accessibility	PDO assignment	Change attribute	Retentive
UINT	0 to 1000	5	0.1ms	RW	Yes	Always	Yes

This specifies the time constant of the torque command filter used as gain group 2 for gain switching. For more information, refer to the description of the Torque Command Filter Time Constant 1 (0x2104).

0x2109	Position Command Filter Time Constant						ALL
Variable type	Setting range	Initial value	Unit	Accessibility	PDO assignment	Change attribute	Retentive
UINT	0 to 10000	0	0.1ms	RW	Yes	Always	Yes

This applies a low pass filter for the position command to smooth out the position command. This can be used for setting a higher gear ratio in particular. It does not apply if the setting is 0.

0x210A	Position Command Average Filter Time Constant						ALL
Variable type	Setting range	Initial value	Unit	Accessibility	PDO assignment	Change attribute	Retentive
UINT	0 to 10000	0	0.1ms	RW	Yes	Always	Yes

This applies a moving average filter for the position command to smooth out the position command. The setting for the position command filter time constant (0x2109) is applied first. It is applied only when the position command filter time constant is 0.

0x210B	Speed Feedback Filter Time Constant						ALL
Variable type	Setting range	Initial value	Unit	Accessibility	PDO assignment	Change attribute	Retentive
UINT	0 to 10000	5	0.1ms	RW	Yes	Always	Yes

This applies a low pass filter to the speed feedback signal calculated from the encoder. In case system vibrations occur or vibrations occur when a gain load with too large of an inertia is applied, you can suppress the vibrations by setting the appropriate value.

0x210C	Velocity Feed-forward Gain						ALL
Variable type	Setting range	Initial value	Unit	Accessibility	PDO assignment	Change attribute	Retentive
UINT	0 to 100	0	%	RW	Yes	Always	Yes

This specifies the feedforward gain for the speed command during position control. The larger the setting is, the less the positional error is. If you set a value that is too large depending on the load, vibrations or overshoot may occur. For gain tuning, increase the setting value gradually.

0x210D	Velocity Feed-forward Filter Time Constant						ALL
Variable type	Setting range	Initial value	Unit	Accessibility	PDO assignment	Change attribute	Retentive
UINT	0 to 1000	10	0.1ms	RW	Yes	Always	Yes

This applies a low pass filter to the compensated amount added to the speed command by the speed feedforward gain. You can enhance the stability of the system by using it when you set a large speed feedforward gain or when there is an excessive change in the position command.

0x210E	Torque Feed-forward Gain						ALL
Variable type	Setting range	Initial value	Unit	Accessibility	PDO assignment	Change attribute	Retentive
UINT	0 to 100	0	%	RW	Yes	Always	Yes

This specifies the feedforward gain for the torque command during speed control.

0x210F	Torque Feed-forward Filter Time Constant						ALL
Variable type	Setting range	Initial value	Unit	Accessi- bility	PDO assignme- nt	Change attribute	Rete- ntive
UINT	0 to 1000	10	0.1ms	RW	Yes	Always	Yes

This applies a low pass filter to the compensated amount added to the torque command by the torque feed-forward gain.

0x2110	Torque Limit Function Select						ALL
Variable type	Setting range	Initial value	Unit	Accessi- bility	PDO assignme- nt	Change attribute	Rete- ntive
UINT	0 to 4	2	-	RW	Yes	Always	Yes

This specifies the function to limit the output torque of the drive.

Settings	Description
0	Limits the torque using forward/reverse torque limit values according to the driving direction; the maximum value is limited by the maximum torque (0x6072). - Forward: 0x60E0, Reverse: 0x60E1
1	Limits the torque by the maximum torque (0x6072) only regardless of the driving direction.
2	Limits the torque using external forward/reverse torque limit values according to the driving direction. - Forward: 0x2111, Reverse: 0x2112
3	Limits the torque using internal and external torque limit values according to the driving direction and the torque limit signal. - Forward: 0x60E0 (if P_CL signal is not input), 0x2111 (if P_CL signal is input) - Reverse: 0x60E1 (if N_CL signal is not input), 0x2112 (if N_CL signal is input)
4	Limited by the analog input torque limit. - Refer to the analog torque limit scale (0x221C) and offset (0x221D).

0x2111	External Positive Torque Limit Value						ALL
Variable type	Setting range	Initial value	Unit	Accessi bility	PDO assignme nt	Change attribute	Rete ntive
UINT	0 to 5000	3000	0.1%	RW	Yes	Always	Yes

This specifies the external forward torque limit value according to the torque limit function setting (0x2110).

0x2112	External Negative Torque Limit Value						ALL
Variable type	Setting range	Initial value	Unit	Accessi bility	PDO assignme nt	Change attribute	Rete ntive
UINT	0 to 5000	3000	0.1%	RW	Yes	Always	Yes

This specifies the external reverse torque limit value according to the torque limit function setting (0x2110).

0x2113	Emergency Stop Torque						ALL
Variable type	Setting range	Initial value	Unit	Accessi bility	PDO assignme nt	Change attribute	Rete ntive
UINT	0 to 5000	1000	0.1%	RW	Yes	Always	Yes

This specifies the stop torque on an emergency stop (when entering POT, NOT, or ESTOP).

0x2114	P/PI Control Conversion Mode						ALL
Variable type	Setting range	Initial value	Unit	Accessi bility	PDO assignme nt	Change attribute	Rete ntive
UINT	0 to 4	0	-	RW	Yes	Always	Yes

This specifies the switch mode between PI control and P control. Using this function, you can improve the speed control characteristics to reduce the overshoot during speed operation and the positioning time during position operation.

0	Always uses PI control.
1	Switches to P control if the command torque is larger than the P control switching torque (0x2115).
2	Switches to P control if the command speed is larger than the P control switching speed (0x2116).
3	Switches to P control if the acceleration command is larger than the P control switching acceleration (0x2117).
4	Switches to P control if the position error is larger than the P control switching position error (0x2118).

0x2115	P Control Switch Torque						ALL
Variable type	Setting range	Initial value	Unit	Accessi bility	PDO assignme nt	Change attribute	Rete ntive
UINT	0 to 5000	500	0.1%	RW	Yes	Always	Yes

Refer to the description of the P/PI control switching mode (0x2114).

0x2116	P Control Switch Speed						ALL
Variable type	Setting range	Initial value	Unit	Accessi bility	PDO assignme nt	Change attribute	Rete ntive
UINT	0 to 6000	100	rpm	RW	Yes	Always	Yes

Refer to the description of the P/PI control switching mode (0x2114).

0x2117	P Control Switch Acceleration						ALL
Variable type	Setting range	Initial value	Unit	Accessi bility	PDO assignme nt	Change attribute	Rete ntive
UINT	0 to 60000	1000	rpm/s	RW	Yes	Always	Yes

Refer to the description of the P/PI control switching mode (0x2114).

0x2118	P Control Switch Following Error						ALL
Variable type	Setting range	Initial value	Unit	Accessi bility	PDO assignme nt	Change attribute	Rete ntive



					nt		
UINT	0 to 60000	100	pulse	RW	Yes	Always	Yes

Refer to the description of the P/PI control switching mode (0x2114).

0x2119	Gain Conversion Mode						ALL
Variable type	Setting range	Initial value	Unit	Accessi bility	PDO assignme nt	Change attribute	Rete ntive
UINT	0 to 7	0	-	RW	Yes	Always	Yes

You can enhance the performance of the entire system by switching between two gain groups. According to the switching mode, manual switch or automatic switch can be done depending on the external input or output signal, respectively.

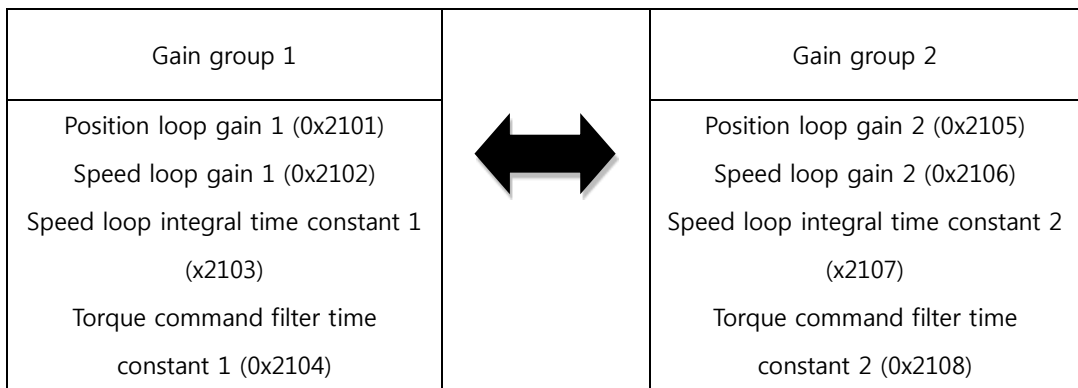

Settings	Setting details
0	Only gain group 1 is used.
1	Only gain group 2 is used.
2	Gain is switched according to the GAIN2 input status. - 0: Use gain group 1 - 1: Use gain group 2
3	Reserved
4	Reserved
5	Reserved
6	Gain is switched according to the ZSPD output status. - 0: Use gain group 1 - 1: Use gain group 2
7	Gain is switched according to the INPOS1 output status. - 0: Use gain group 1 - 1: Use gain group 2

0x211A	Gain Conversion Time 1						ALL
Variable type	Setting range	Initial value	Unit	Accessi- bility	PDO assignme- nt	Change attribute	Rete- ntive
UINT	0 to 1000	2	ms	RW	Yes	Always	Yes

This specifies the time to switch from gain group 1 to gain group 2.

0x211B	Gain Conversion Time 2						ALL
Variable type	Setting range	Initial value	Unit	Accessi- bility	PDO assignme- nt	Change attribute	Rete- ntive
UINT	0 to 1000	2	ms	RW	Yes	Always	Yes

This specifies the time to switch from gain group 2 to gain group 1.

0x211C	Gain Conversion Waiting Time 1						ALL
Variable type	Setting range	Initial value	Unit	Accessi- bility	PDO assignme- nt	Change attribute	Rete- ntive
UINT	0 to 1000	0	ms	RW	Yes	Always	Yes

This specifies the waiting time before switching from gain group 1 to gain group 2.

0x211D	Gain Conversion Waiting Time 2						ALL
Variable type	Setting range	Initial value	Unit	Accessi- bility	PDO assignme- nt	Change attribute	Rete- ntive
UINT	0 to 1000	0	ms	RW	Yes	Always	Yes

This specifies the waiting time before switching from gain group 2 to gain group 1.

0x211E	Dead Band for Position Control						ALL
Variable type	Setting range	Initial value	Unit	Accessi- bility	PDO assignme- nt	Change attribute	Rete- ntive

UINT	0 to 1000	0	UU	RW	Yes	Always	Yes
------	-----------	---	----	----	-----	--------	-----

The position controller output is 0 if the positional error for position control is below the setting.

0x211F Drive Control Input 1							
Variable type	Setting range	Initial value	Unit	Accessi bility	PDO assignme nt	Change attribute	Rete ntive
UINT	0 to FFFF <sub>hex</sub>	0	-	RW	Yes	Always	No

For the drive input contact point signal, you can enter the same input value by setting the bit for the input value using this setting, in addition to using the signal that is received through the I/O connector. An applicable function will be performed by logical OR operation of the signal input through the I/O connector and the bit value of this setting.

Refer to the table below for the input contact points that are available for configuration.

Bit	Setting details
0	POT
1	NOT
2	HOME
3	STOP
4	PCON
5	GAIN2
6	P_CL
7	N_CL
8	MODE
9	Reserved
10	EMG
11	A_RST
12	SV_ON
13	SPD1
14	SPD2
15	SPD3

0x2120 Drive Control Input 2							
Variable type	Setting range	Initial value	Unit	Accessi bility	PDO assignme nt	Change attribute	Rete ntive
UINT	0 to FFFF <sub>hex</sub>	0	-	RW	Yes	Always	No

This function is the same as [0x211F]. Only the available settings are different. Refer to the table below for the input contact points that are available for configuration.

Bit	Setting details
0	START
1	PAUSE
2	REGT
3	HSTART
4	ISEL0
5	ISEL1
6	ISEL2
7	ISEL3
8	ISEL4
9	ISEL5
10	ABSRQ
11	JSTART
12	JDIR
13	PCLEAR
14	AOVR
15	INHIB

0x2121	Drive Status Output 1						ALL
Variable type	Setting range	Initial value	Unit	Accessi bility	PDO assignme nt	Change attribute	Rete ntive
UINT	0 to FFFF <sub>hex</sub>	0	-	RO	Yes	-	No

You can assign the state of the drive output signal to the output signal of the I/O connector in order to verify the applicable bit of this output value, in addition to the actual output.

Bit	Setting details
0	BRAKE
1	ALARM
2	READY
3	ZSPD
4	INPOS1
5	TLMT
6	VLMT
7	INSPD
8	WARN
9	TGON
10	INPOS2
15-11	Reserved

0x2122		Drive Status Output 2					ALL
Variable type	Setting range	Initial value	Unit	Accessi bility	PDO assignme nt	Change attribute	Rete ntive
UINT	0 to FFFF <sub>hex</sub>	0	-	RO	Yes	-	No

You can assign the state of the drive output signal to the output signal of the I/O connector in order to verify the applicable bit of this output value, in addition to the actual output.

Bit	Setting details
0	ORG
1	EOS
2	IOUT0
3	IOUT1
4	IOUT2
5	IOUT3
6	IOUT4
7	IOUT5
15~8	Reserved

• I/O Configuration(0x2200~ )

0x2200	Digital Input Signal 1 Selection						ALL
Variable type	Setting range	Initial value	Unit	Accessi bility	PDO assignme nt	Change attribute	Rete ntive
UINT	0 to 0xFFFF	0x000F	-	RW	No	Always	Yes

This specifies the functions of digital input signal 1 of the I/O connector and the input signal level.

Bit	Setting details
15	Signal input level settings (0: contact A, 1: contact B)
14~8	Reserved
7~0	Input signal assignments

Setting example: If the setting is 0x0006

0	0	0	6
Contact A		GAIN2 is assigned.	

Setting example: If the setting is 0x8002

8	0	0	2
Contact B		NOT is assigned.	

Settings	Assigned signal
0x00	Not assigned
0x01	POT
0x02	NOT
0x03	HOME
0x04	STOP
0x05	PCON
0x06	GAIN2
0x07	P_CL
0x08	N_CL
0x09	PROBE1
0x0A	PROBE2
0x0B	EMG
0x0C	A_RST
0x0F	SV_ON
0x10	START
0x11	PAUSE
0x12	REGT
0x13	HSTART
0x14	ISEL0
0x15	ISEL1
0x16	ISEL2
0x17	ISEL3
0x18	ISEL4
0x19	ISEL5
0x1A	ABSRQ
0x1B	JSTART
0x1C	JDIR
0x1D	PCLR
0x1E	AOVR
0x1F	INBIT
0x20	SPD1/LVSF1
0x21	SPD2/LVSF2
0x22	SPD3
0x23	MODE

0x2201	Digital Input Signal 2 Selection						ALL
Variable type	Setting range	Initial value	Unit	Accessibility	PDO assignment	Change attribute	Retentive
UINT	0 to 0xFFFF	0x0001	-	RW	No	Always	Yes

This specifies the functions of digital input signal 2 of the I/O connector and the input signal level. For more information, refer to the description of 0x2200.

0x2202	Digital Input Signal 3 Selection						ALL
Variable type	Setting range	Initial value	Unit	Accessibility	PDO assignment	Change attribute	Retentive
UINT	0 to 0xFFFF	0x0002	-	RW	No	Always	Yes

This specifies the functions of digital input signal 3 of the I/O connector and the input signal level. For more information, refer to the description of 0x2200.

0x2203	Digital Input Signal 4 Selection						ALL
Variable type	Setting range	Initial value	Unit	Accessibility	PDO assignment	Change attribute	Retentive
UINT	0 to 0xFFFF	0x000C	-	RW	No	Always	Yes

This specifies the functions of digital input signal 4 of the I/O connector and the input signal level. For more information, refer to the description of 0x2200.

0x2210	Digital Output Signal 1 Selection						ALL
Variable type	Setting range	Initial value	Unit	Accessibility	PDO assignment	Change attribute	Retentive
UINT	0 to 0xFFFF	0x8002	-	RW	No	Always	Yes

This assigns the digital output signal 1 function and sets the output signal level of the I/O connector.

Setting example: If the setting is 0x8001

8	0	0	1
Contact B		Brake assigned	

Bit	Setting details
15	Signal output level settings (0: contact A, 1: contact B)
14~8	Reserved
7~0	Output signal assignments

Settings	Assigned signal
0x00	Not assigned
0x01	BRAKE
0x02	ALARM
0x03	READY
0x04	ZSPD
0x05	INPOS1
0x06	TLMT
0x07	VLMT
0x08	INSPD
0x09	WARN
0x0A	TGON
0x0B	INPOS2
0x10	ORG
0x11	EOS
0x12	IOUT0
0x13	IOUT1
0x14	IOUT2
0x15	IOUT3
0x16	IOUT4
0x17	IOUT5

0x2211	Digital Output Signal 2 Selection						ALL
Variable type	Setting range	Initial value	Unit	Accessi- bility	PDO assignme- nt	Change attribute	Rete- ntive
UINT	0 to 0xFFFF	0x0003	-	RW	No	Always	Yes

This sets the digital output signal 2 function and output signal level of the I/O connector. For more information, refer to the description of 0x2210.

0x2212	Digital Output Signal 3 Selection						ALL
Variable type	Setting range	Initial value	Unit	Accessi- bility	PDO assignme- nt	Change attribute	Rete- ntive
UINT	0 to 0xFFFF	0x8001 <sub>x</sub>	-	RW	No	Always	Yes

This sets the digital output signal 3 function and output signal level of the I/O connector. For more information, refer to the description of 0x2210.



0x2213	Digital Output Signal 4 Selection						ALL
Variable type	Setting range	Initial value	Unit	Accessi bility	PDO assignme nt	Change attribute	Rete ntive
UINT	0 to 0xFFFF	0x0005	-	RW	No	Always	Yes

This sets the digital output signal 4 function and output signal level of the I/O connector. For more information, refer to the description of 0x2210.

0x221C	Analog Torque Input(command/limit) Scale						ALL
Variable type	Setting range	Initial value	Unit	Accessi bility	PDO assignme nt	Change attribute	Rete ntive
UINT	-1000 to 1000	100	0.1%/V	RW	No	Always	Yes

If it is not a torque operation and the value of torque limit function setting (0x2110) is 4 (analog torque limit), the torque is limited by the analog input torque limit. Set the scale of the analog input value at this time.

In the case of torque operation, the parameter is used as the analog torque command scale. The selected value sets the torque command at an analog input voltage of  $\pm 10$  V as a percentage of the rated torque.

0x221D	Analog Torque Input(command/limit) Offset						ALL
Variable type	Setting range	Initial value	Unit	Accessi bility	PDO assignme nt	Change attribute	Rete ntive
INT	-1000 to 1000	0	mV	RW	No	Always	Yes

If it is not torque operation, this specifies the analog voltage offset controlled by the analog torque limit.

In the case of torque operation, the parameter is used as the analog torque command scale.

0x221F	Analog Velocity Input(command/override) Offset						P, S
Variable	Setting range	Initial	Unit	Accessi	PDO	Change	Rete

type		value		bility	assignme nt	attribute	ntive
INT	-1000 to 1000	0	mV	RW	No	Always	Yes

In the case of indexing position operations, it sets the analog voltage offset that is received as the analog speed override. In the case of speed operations, it sets the analog voltage offset that is received as the analog speed command.

0x2220	Analog Monitor Output Mode							ALL
Variable type	Setting range	Initial value	Unit	Accessi bility	PDO assignme nt	Change attribute	Rete ntive	
UINT	0 to 1	0	-	RW	No	Always	Yes	

The output range of the analog monitor is from -10 V to +10 V. If the setting is 1, take the absolute value of the output so the output values is only positive.

Settings	Setting details
0	Output as negative/positive values
1	Output as positive values only

0x2221	Analog Monitor Channel 1 Select							ALL
Variable type	Setting range	Initial value	Unit	Accessi bility	PDO assignme nt	Change attribute	Rete ntive	
UINT	0 to 65535	0	-	RW	No	Always	Yes	

This configures the monitoring variables to be output to analog monitor output channel 1.

Settings	Displayed item	Unit
0	Speed feedback	rpm
1	Speed command	rpm
2	Speed error	rpm
3	Torque feedback	%
4	Torque command	%
5	Position error	pulse
6	Accumulated operation overload	%
7	DC link voltage	V
8	Reserved	%

9	Encoder single-turn data	pulse
10	Inertia ratio	%
11	Following Error Actual Value	UU
12	Drive temperature 1	°C
13	Drive temperature 2	°C
14	Encoder temperature (reserved)	°C
15	Hall sensor signal	
16	U-phase current	A
17	V-phase current	A
18	W-phase current	A
19	Actual position value	UU
20	Position demand value	UU
21	Position command speed	rpm
22	Hall U Value	
23	Hall V Value	
24	Hall W Value	

0x2222		Analog Monitor Channel 2 Select					ALL
Variable type	Setting range	Initial value	Unit	Accessi bility	PDO assignme nt	Change attribute	Rete ntive
UINT	0 to 65535	1	-	RW	No	Always	Yes

This configures the monitoring variables to be output to analog monitor output channel 2.

0x2223		Analog Monitor Channel 1 Offset					ALL
Variable type	Setting range	Initial value	Unit	Accessi bility	PDO assignme nt	Change attribute	Rete ntive
DINT	0 to 0x40000000	0	-	RW	No	Always	Yes

Subtract the offset value from the monitoring variable of analog monitor output channel 1 to determine the final output. The unit will be that of the variable configured in the Analog Monitor Channel 1 Setting (0x2221).

0x2224		Analog Monitor Channel 2 Offset					ALL
--------	--	---------------------------------	--	--	--	--	-----

Variable type	Setting range	Initial value	Unit	Accessibility	PDO assignment	Change attribute	Retentive
DINT	0 to 0x40000000	0	-	RW	No	Always	Yes

Subtract the offset value from the monitoring variable of analog monitor output channel 2 to determine the final output. The unit will be that of the variable configured in the Analog Monitor Channel 2 Setting (0x2222).

0x2225	Analog Monitor Channel 1 Scale							ALL
Variable type	Setting range	Initial value	Unit	Accessibility	PDO assignment	Change attribute	Retentive	
UDINT	0 to 0x40000000	500	-	RW	No	Always	Yes	

This specifies the scaling of the variable to be output per 1 V when outputting the monitoring variable configured as analog output channel 1. The unit will be that of the variable configured in the Analog Monitor Channel 1 Setting (0x2221) per 1 V.

For example, if you set the speed feedback to channel 1 and the scale to 500, up to ±5000 rpm can be output as ±10 V.

0x2226	Analog Monitor Channel 2 Scale							ALL
Variable type	Setting range	Initial value	Unit	Accessibility	PDO assignment	Change attribute	Retentive	
UDINT	0 to 0x40000000	500	-	RW	No	Always	Yes	

This specifies the scaling of the variable to be output per 1 V when outputting the monitoring variable configured as analog output channel 2. The unit will be that of the variable configured in the Analog Monitor Channel 2 Setting (0x2222) per 1 V.

0x2227	Analog Velocity Command Filter Time Constant							S
Variable type	Setting range	Initial value	Unit	Accessibility	PDO assignment	Change attribute	Retentive	
UINT	0 to 1000	2	0.1ms	RW	No	Always	Yes	

You can set the digital filter for the analog speed command voltage to improve the stability of the command signal. If the filter value is set too high, responsiveness to speed commands will be reduced. It is important to set a value that is appropriate for your system.

0x2228	Analog Torque Command Filter Time Constant						T
Variable type	Setting range	Initial value	Unit	Accessi- bility	PDO assignme- nt	Change attribute	Rete- ntive
UINT	0 to 1000	2	0.1ms	RW	No	Always	Yes

You can set the digital filter for the analog torque command voltage to improve the stability of the command signal. If the filter value is set too high, responsiveness to torque commands will be reduced. It is important to set a value that is appropriate for your system.

0x2229	Analog Velocity Command Scale						S
Variable type	Setting range	Initial value	Unit	Accessi- bility	PDO assignme- nt	Change attribute	Rete- ntive
INT	-1000 to 1000	100	rpm/V	RW	No	Always	Yes

If you control speed with the analog voltage in speed operation, the analog speed command value at  $\pm 10[V]$  is set in rpm. If the setting is 100, you can control up to 100 rpm per 1 V command voltage.

0x222A	Analog Velocity Command Clamp Level						S
Variable type	Setting range	Initial value	Unit	Accessi- bility	PDO assignme- nt	Change attribute	Rete- ntive
UINT	0 to 1000	0	rpm	RW	No	Always	Yes

If you control speed with the analog voltage in speed operation, voltage may remain on the analog signal connection circuit even at the 0 speed command.

In this case, zero speed can be maintained for the command that corresponds to the set speed value.

0x222B	Analog Input Function Select						ALL
Variable	Setting range	Initial	Unit	Accessi-	PDO	Change	Rete

type		value		bility	assignme nt	attribute	ntive
UINT	0 to 3	0	-	RW	No	Power cycling	Yes

This selects the analog input function that is received through the I/O connector (pins 5 - 6).

Settings	Description
0	Used only as a function of each mode (speed command in the case of speed control, torque command in the case of torque control)
1	Analog torque limit (The 0x221C setting, which operates in modes other than scale and torque control modes) (It operates only when 0x2110 is set to 4.)
2	Analog speed limit (The 0x2229 setting, which operates in the scale and torque control modes) (0x230D needs to be set, 2: limited by analog input, 3: limited to the smaller value between the analog input and 0x230E setting)
3	Used as speed override

0x2237 Motor Brake Fitted							
Variable type	Setting range	Initial value	Unit	Accessi bility	PDO assignme nt	Change attribute	Rete ntive
UINT	0 to 1	0	-	RW	No	Power cycling	Yes

This sets whether to apply the motor brake. The brake-related circuit inside the drive operates only when the parameter is set to 1.

Settings	Description
0	Not attached
1	Attached

## • Velocity Control(0x2300~ )

0x2300	Jog Operation Speed						ALL
Variable type	Setting range	Initial value	Unit	Accessi bility	PDO assignme nt	Change attribute	Rete ntive
INT	-6000 to 6000	500	rpm	RW	No	Always	Yes

This specifies the jog operation speed.

0x2301	Speed Command Acceleration Time						ALL
Variable type	Setting range	Initial value	Unit	Accessi bility	PDO assignme nt	Change attribute	Rete ntive
UINT	0 to 10000	200	ms	RW	No	Always	Yes

This specifies the time, in ms, required for the motor to reach the rated motor speed from zero speed.

0x2302	Speed Command Deceleration Time						ALL
Variable type	Setting range	Initial value	Unit	Accessi bility	PDO assignme nt	Change attribute	Rete ntive
UINT	0 to 10000	200	ms	RW	No	Always	Yes

This specifies the time, in ms, required for the motor to decelerate from the rated motor speed to a stop.

0x2303	Speed Command S-curve Time						ALL
Variable type	Setting range	Initial value	Unit	Accessi bility	PDO assignme nt	Change attribute	Rete ntive
UINT	0 to 1000	0	ms	RW	No	Always	Yes

You can configure the speed command in an S-curve pattern for smooth acceleration/deceleration. If it is set to 0, the drive will be operated in a trapezoidal pattern by default.

0x2304	Program Jog Operation Speed 1						ALL
Variable type	Setting range	Initial value	Unit	Accessi bility	PDO assignme nt	Change attribute	Rete ntive
INT	-6000 to 6000	0	rpm	RW	No	Always	Yes

For programmed jog operation, you can set operation speed 1 to 4 and operation time 1 to 4 as follows:

0x2305	Program Jog Operation Speed 2						ALL
Variable type	Setting range	Initial value	Unit	Accessi bility	PDO assignme nt	Change attribute	Rete ntive
INT	-6000 to 6000	500	rpm	RW	No	Always	Yes

Refer to the description of Programmed Jog Operation Speed 1 (0x2304).

0x2306	Program Jog Operation Speed 3						ALL
Variable type	Setting range	Initial value	Unit	Accessi bility	PDO assignme nt	Change attribute	Rete ntive
INT	-6000 to 6000	0	rpm	RW	No	Always	Yes

Refer to the description of Programmed Jog Operation Speed 1 (0x2304).

0x2307	Program Jog Operation Speed 4						ALL
Variable type	Setting range	Initial value	Unit	Accessi bility	PDO assignme nt	Change attribute	Rete ntive
INT	-6000 to 6000	-500	rpm	RW	No	Always	Yes

Refer to the description of Programmed Jog Operation Speed 1 (0x2304).

0x2308	Program Jog Operation Time 1						ALL
Variable type	Setting range	Initial value	Unit	Accessi bility	PDO assignme nt	Change attribute	Rete ntive



					nt		
UINT	0 to 10000	500	ms	RW	No	Always	Yes

Refer to the description of Programmed Jog Operation Speed 1 (0x2304).

0x2309	Program Jog Operation Time 2						ALL
Variable type	Setting range	Initial value	Unit	Accessi bility	PDO assignme nt	Change attribute	Rete ntive
UINT	0 to 10000	5000	ms	RW	No	Always	Yes

Refer to the description of Programmed Jog Operation Speed 1 (0x2304).

0x230A	Program Jog Operation Time 3						ALL
Variable type	Setting range	Initial value	Unit	Accessi bility	PDO assignme nt	Change attribute	Rete ntive
UINT	0 to 10000	500	ms	RW	No	Always	Yes

Refer to the description of Programmed Jog Operation Speed 1 (0x2304).

0x230B	Program Jog Operation Time 4						ALL
Variable type	Setting range	Initial value	Unit	Accessi bility	PDO assignme nt	Change attribute	Rete ntive
UINT	0 to 10000	5000	ms	RW	No	Always	Yes

Refer to the description of Programmed Jog Operation Speed 1 (0x2304).

0x230C	Index Pulse Search Speed						ALL
Variable type	Setting range	Initial value	Unit	Accessi bility	PDO assignme nt	Change attribute	Rete ntive
INT	-1000 to 1000	20	rpm	RW	No	Always	Yes

This specifies the speed for index pulse search.

0x230D Speed Limit Function Select								T
Variable type	Setting range	Initial value	Unit	Accessi- bility	PDO assignme- nt	Change attribute	Rete- ntive	
UINT	0 to 3	0	-	RW	No	Always	Yes	

This specifies the speed limit function for torque control.

Settings	Setting details
0	Limited by the speed limit value (0x230E)
1	Limited by the maximum motor speed

0x230E Speed Limit Value at Torque Control Mode								T
Variable type	Setting range	Initial value	Unit	Accessi- bility	PDO assignme- nt	Change attribute	Rete- ntive	
UINT	0 to 6000	1000	rpm	RW	Yes	Always	Yes	

This specifies the speed limit value for torque control. This setting is applied only when the Speed Limit Function Setting (0x230D) is set to 0.

0x230F Over Speed Dection Level								ALL
Variable type	Setting range	Initial value	Unit	Accessi- bility	PDO assignme- nt	Change attribute	Rete- ntive	
UINT	0 to 10000	6000	rpm	RW	No	Always	Yes	

This specifies the level to detect overspeed alarms (AL-50). If the setting is larger than the maximum motor speed, the detection level will be set by the maximum motor speed.

0x2310 Excessive Speed Error Detection Level								ALL
Variable type	Setting range	Initial value	Unit	Accessi- bility	PDO assignme- nt	Change attribute	Rete- ntive	
UINT	0 to 10000	5000	rpm	RW	No	Always	Yes	

This specifies the level to detect excessive speed error alarms (AL-53). If the difference between the speed command and the speed feedback exceeds the setting value, an excessive speed error alarm is generated.

0x2311	Servo-Lock Function Select						S
Variable type	Setting range	Initial value	Unit	Accessi- bility	PDO assignme- nt	Change attribute	Rete- ntive
UINT	0 to 1	0	-	RW	No	Always	Yes

This specifies the servo-lock function to fix the motor position with a position value when the speed command is input as 0 for speed control.

Settings	Setting details
0	Servo-lock function disabled
1	Servo-lock function enabled

0x2312	Multi-Step Operation Speed 1						S
Variable type	Setting range	Initial value	Unit	Accessi- bility	PDO assignme- nt	Change attribute	Rete- ntive
INT	-32768 to 32767	0	rpm	RW	No	Always	Yes

This sets the speed for multi-stage operation velocity 1 in speed operation mode. This is the speed when input contact points for SPD1, SPD2, and SPD3 are off.

0x2313	Multi-Step Operation Speed 2						S
Variable type	Setting range	Initial value	Unit	Accessi- bility	PDO assignme- nt	Change attribute	Rete- ntive
INT	-32768 to 32767	10	rpm	RW	No	Always	Yes

This sets the speed for multi-stage operation velocity 2 in speed operation mode. This is the speed when the input contact point for SPD1 is on and input contact points for SPD2 and SPD3 are off.

0x2314	Multi-Step Operation Speed 3						S
Variable type	Setting range	Initial value	Unit	Accessi- bility	PDO assignme- nt	Change attribute	Rete- ntive
INT	-32768 to 32767	50	rpm	RW	No	Always	Yes

This sets the speed for multi-stage operation velocity 3 in speed operation mode. This is the speed when the input contact point for SPD2 is on and input contact points for SPD1 and SPD3 are off.

0x2315	Multi-Step Operation Speed 4						S
Variable type	Setting range	Initial value	Unit	Accessi- bility	PDO assignme- nt	Change attribute	Rete- ntive
INT	-32768 to 32767	100	rpm	RW	No	Always	Yes

This sets the speed for multi-stage operation velocity 4 in speed operation mode. This is the speed when input contact points for SPD1 and SPD2 are on and the input contact point for SPD3 is off.

0x2316	Multi-Step Operation Speed 5						S
Variable type	Setting range	Initial value	Unit	Accessi- bility	PDO assignme- nt	Change attribute	Rete- ntive
INT	-32768 to 32767	200	rpm	RW	No	Always	Yes

This sets the speed for multi-stage operation velocity 5 in speed operation mode. This is the speed when the input contact point for SPD3 is on and input contact points for SPD1 and SPD2 are off.

0x2317	Multi-Step Operation Speed 6						S
Variable type	Setting range	Initial value	Unit	Accessi- bility	PDO assignme- nt	Change attribute	Rete- ntive
INT	-32768 to 32767	500	rpm	RW	No	Always	Yes

This sets the speed for multi-stage operation velocity 6 in speed operation mode. This is the speed when input contact points for SPD1 and SPD3 are on and the input contact point for SPD2 is off.

0x2318	Multi-Step Operation Speed 7						S
Variable type	Setting range	Initial value	Unit	Accessibility	PDO assignment	Change attribute	Retentive
INT	-32768 to 32767	1000	rpm	RW	No	Always	Yes

This sets the speed for multi-stage operation velocity 7 in speed operation mode. This is the speed when input contact points for SPD2 and SPD3 are on and the input contact point for SPD1 is off.

0x2319	Multi-Step Operation Speed 8						S
Variable type	Setting range	Initial value	Unit	Accessibility	PDO assignment	Change attribute	Retentive
INT	-32768 to 32767	1500	rpm	RW	No	Always	Yes

This sets the speed for multi-stage operation velocity 8 in speed operation mode. This is the speed when input contact points for SPD1, SPD2, and SPD3 are on.

0x231A	Velocity Command Switch Select						S
Variable type	Setting range	Initial value	Unit	Accessibility	PDO assignment	Change attribute	Retentive
UINT	0 to 3	0	-	RW	No	Always	Yes

This selects the speed command method in speed operation mode.

Settings	Setting details
0	Analog speed command is used.
1	SPD1 and SPD2 contact points and analog speed command are used.
2	SPD1, SPD2, and SPD3 contact points and analog speed command are used.
3	Speed commands of SPD1, SPD2, and SPD3 contact points are used.

If the setting is 1 or 2 and the corresponding contact point is on, it uses the analog speed command.

E.g. 1) If the setting is 2 and the SPD1 and SPD2 contact points are on, the analog speed command 10 V is applied.

The motor operates at 100 rpm. The analog input speed command is ignored.

The operating speed is activated by the parameter 0x2315 setting.

E.g. 2) If the setting is 2 and the SPD1, SPD2, and SPD3 contact points are on, the analog speed command 10 V is applied.

The motor operates at 1000 rpm. The speed command of the digital input/output contact point is ignored.

The operating speed is applied by an analog speed command voltage based on the parameter 0x2229 setting.

## • Miscellaneous Setting(0x2400~ )

0x2400	Software Position Limit Function Select						ALL
Variable type	Setting range	Initial value	Unit	Accessibility	PDO assignment	Change attribute	Retentive
UINT	0 to 3	0	-	RW	No	Always	Yes

This specifies the software position limit function for position control. When using the position limit function, the upper and the lower limit values will be limited to the values configured in (0x670D:02) and (0x670D:01), respectively. The software position limit function will not be activated prior to the homing operation. In addition, when the upper limit value is less than the lower limit value, this function will not be activated.

Settings	Setting details
0	None of positive and negative software position limits are used.
1	Only the positive software position limit value is used. It is not limited for the reverse direction.
2	Only the negative software position limit value is used. It is not limited for the forward direction.
3	Both the positive and the negative software position limits are used.

0x2401	INPOS1 Output Range						P
Variable type	Setting range	Initial value	Unit	Accessibility	PDO assignment	Change attribute	Retentive
UINT	0 to 60000	100	UU	RW	Yes	Always	Yes

With the position command not newly updated, if the position error is retained within the INPOS1 output range for the INPOS1 output time, the INPOS1 signal is output.

0x2402	INPOS1 Output Time						P
Variable type	Setting range	Initial value	Unit	Accessibility	PDO assignment	Change attribute	Retentive
UINT	0 to 1000	0	ms	RW	Yes	Always	Yes

Refer to the description of 0x2401.

0x2403	INPOS2 Output Range						P
Variable type	Setting range	Initial value	Unit	Accessi bility	PDO assignme nt	Change attribute	Rete ntive
UINT	0 to 60000	100	UU	RW	Yes	Always	Yes

This outputs the INPOS2 signal where the position error is less than the setting value. Unlike the INPOS1, the INPOS2 signal is output by calculating only the position error value.

0x2404	ZSPD Output Range						P
Variable type	Setting range	Initial value	Unit	Accessi bility	PDO assignme nt	Change attribute	Rete ntive
UINT	0 to 6000	10	rpm	RW	Yes	Always	Yes

When the current speed is less than the setting value, the ZSPD signal is output.

0x2405	TGON Output Range						P
Variable type	Setting range	Initial value	Unit	Accessi bility	PDO assignme nt	Change attribute	Rete ntive
UINT	0 to 6000	100	rpm	RW	Yes	Always	Yes

When the current speed is more than the setting value, the TGON signal is output.

0x2406	INSPD Output Range						P
Variable type	Setting range	Initial value	Unit	Accessi bility	PDO assignme nt	Change attribute	Rete ntive
UINT	0 to 6000	100	rpm	RW	Yes	Always	Yes

When the speed error is less than the setting value, the INSPD signal is output.

0x2407	BRAKE Output Speed						P
Variable type	Setting range	Initial value	Unit	Accessi bility	PDO assignme nt	Change attribute	Rete ntive



UINT	0 to 6000	100	rpm	RW	No	Always	Yes
------	-----------	-----	-----	----	----	--------	-----

If the motor stops because the servo turns off or a servo alarm occurs during rotation, you can set the speed (0x2407) and delay time (0x2408) for the brake signal output to configure the output timing. The brake signal will be output if the motor rotation speed goes below the set speed (0x2407) or the output delay time (0x2408) has elapsed after the servo OFF command.

0x2408	BRAKE Output Delay Time						P
Variable type	Setting range	Initial value	Unit	Accessi bility	PDO assignme nt	Change attribute	Rete ntive
UINT	0 to 1000	100	ms	RW	No	Always	Yes

Refer to the description of 0x2407.

0x2409	Torque Limit at Homing Using Stopper						ALL
Variable type	Setting range	Initial value	Unit	Accessi bility	PDO assignme nt	Change attribute	Rete ntive
UINT	0 to 2000	250	0.1%	RW	No	Always	Yes

This specifies the torque limit value for homing using a stopper. With too large of a value configured, the machine may collide with the stopper, so be careful.

0x240A	Duration Time at Homing Using Stopper						ALL
Variable type	Setting range	Initial value	Unit	Accessi bility	PDO assignme nt	Change attribute	Rete ntive
UINT	0 to 1000	50	ms	RW	No	Always	Yes

This specifies the time to detect the stopper for homing using a stopper. Set the appropriate value, depending on the machine.

0x240B	Modulo Mode						ALL
Variable type	Setting range	Initial value	Unit	Accessi bility	PDO assignme nt	Change attribute	Rete ntive

UINT	0 to 5	0	-	RW	No	Power cycling	Yes
------	--------	---	---	----	----	---------------	-----

This sets whether to use the modulo function. (L7P is determined based on the coordinate axis and index type.)

Settings	Setting details
0	Does not use the modulo function.
1	Uses the modulo function to move forward.
2	Uses the modulo function to move backward.
3	Uses the modulo function to move via the possible shortest distance.
4	Reserved
5	Reserved

0x240C	Modulo Factor						ALL
Variable type	Setting range	Initial value	Unit	Accessi bility	PDO assignme nt	Change attribute	Rete ntive
DINT	1 to 0x40000000	3600	UU	RW	No	Power cycling	Yes

This specifies the factor for using the modulo function. It sets the position value per revolution when the user operates the motor.

0x240D	User Drive Name						ALL
Variable type	Setting range	Initial value	Unit	Accessi bility	PDO assignme nt	Change attribute	Rete ntive
STRING	-	'Drive'	-	RW	No	Always	Yes

The user can customize the drive name. Up to 16 characters can be used to define the name.

0x240E	Individual Parameter Save						ALL
Variable type	Setting range	Initial value	Unit	Accessi bility	PDO assignme nt	Change attribute	Rete ntive
UINT	0 to 1	0	-	RW	No	Always	No

This specifies whether to save parameters individually. This parameter is not saved and is initialized to 0 during power ON.

Settings	Setting details
0	Parameters are not saved individually. For details on storing parameters, refer to Storing Parameters (0x1010).
1	Save the parameters individually. When a parameter is written, it is immediately stored in the memory.

0x240F	RMS Overload Calculation Time						ALL
Variable type	Setting range	Initial value	Unit	Accessi- bility	PDO assignme- nt	Change attribute	Rete- ntive
UINT	100 to 60000	15000	ms	RW	No	Power cycling	Yes

This sets the time to calculate RMS operation overload (0x2619).

0x2410	RTC Time Set						ALL
Variable type	Setting range	Initial value	Unit	Accessi- bility	PDO assignme- nt	Change attribute	Rete- ntive
UDINT	0 to 0xFFFFFFFF		-	RW	No	Always	Yes

This sets the RTC time.

0x2411	RTC Date Set						ALL
Variable type	Setting range	Initial value	Unit	Accessi- bility	PDO assignme- nt	Change attribute	Rete- ntive
UDINT	0 to 0xFFFFFFFF		-	RW	No	Always	Yes

This sets the RTC date.

• Enhanced Control(0x2500~ )

0x2500	Adaptive Filter Function Select						ALL
Variable type	Setting range	Initial value	Unit	Accessi bility	PDO assignme nt	Change attribute	Rete ntive
UINT	0 to 5	0	-	RW	No	Always	Yes

This specifies the adaptive filter function.

Settings	Setting details
0	Adaptive filter is not used.
1	Only one adaptive filter is used. You can check the settings configured automatically in the notch filter 4 settings (0x250A and 0x250B).
2	Only two adaptive filters are used. You can check the settings configured automatically in the notch filter 3 (0x2507 and 0x2508) and filter 4 settings (0x250A and 0x250B).
3	Reserved
4	Resets the notch filter 3 (0x2507, 0x2508) and notch filter 4 (0x250A, 0x250B, 0x250C) settings.
5	Reserved

0x2501	Notch Filter 1 Frequency						ALL
Variable type	Setting range	Initial value	Unit	Accessi bility	PDO assignme nt	Change attribute	Rete ntive
UINT	50 to 5000	5000	Hz	RW	No	Always	Yes

This specifies the frequency of notch filter 1.

0x2502	Notch Filter 1 Width						ALL
Variable type	Setting range	Initial value	Unit	Accessi bility	PDO assignme nt	Change attribute	Rete ntive
UINT	1 to 100	1	-	RW	No	Always	Yes

This specifies the width of notch filter 1.

0x2503	Notch Filter 1 Depth						ALL
Variable	Setting range	Initial	Unit	Accessi	PDO	Change	Rete

type		value		bility	assignme nt	attribute	ntive
UINT	1 to 5	1	-	RW	No	Always	Yes

This specifies the depth of notch filter 1.

0x2504	Notch Filter 2 Frequency							ALL
Variable type	Setting range	Initial value	Unit	Accessi bility	PDO assignme nt	Change attribute	Rete ntive	
UINT	50 to 5000	5000	Hz	RW	No	Always	Yes	

0x2505	Notch Filter 2 Width							ALL
Variable type	Setting range	Initial value	Unit	Accessi bility	PDO assignme nt	Change attribute	Rete ntive	
UINT	1 to 100	1	-	RW	No	Always	Yes	

0x2506	Notch Filter 2 Depth							ALL
Variable type	Setting range	Initial value	Unit	Accessi bility	PDO assignme nt	Change attribute	Rete ntive	
UINT	1 to 5	1	-	RW	No	Always	Yes	

0x2507	Notch Filter 3 Frequency							ALL
Variable type	Setting range	Initial value	Unit	Accessi bility	PDO assignme nt	Change attribute	Rete ntive	
UINT	50 to 5000	5000	Hz	RW	No	Always	Yes	

0x2508	Notch Filter 3 Width							ALL
Variable type	Setting range	Initial value	Unit	Accessi bility	PDO assignme	Change attribute	Rete ntive	

					nt		
UINT	1 to 100	1	-	RW	No	Always	Yes

0x2509	Notch Filter 3 Depth						ALL
Variable type	Setting range	Initial value	Unit	Accessi bility	PDO assignme nt	Change attribute	Rete ntive
UINT	1 to 5	1	-	RW	No	Always	Yes

0x250A	Notch Filter 4 Frequency						ALL
Variable type	Setting range	Initial value	Unit	Accessi bility	PDO assignme nt	Change attribute	Rete ntive
UINT	50 to 5000	5000	Hz	RW	No	Always	Yes

0x250B	Notch Filter 4 Width						ALL
Variable type	Setting range	Initial value	Unit	Accessi bility	PDO assignme nt	Change attribute	Rete ntive
UINT	1 to 100	1	-	RW	No	Always	Yes

0x250C	Notch Filter 4 Depth						ALL
Variable type	Setting range	Initial value	Unit	Accessi bility	PDO assignme nt	Change attribute	Rete ntive
UINT	1 to 5	1	-	RW	No	Always	Yes

0x250D	On-line Gain Tuning Mode						ALL
Variable type	Setting range	Initial value	Unit	Accessi bility	PDO assignme nt	Change attribute	Rete ntive

UINT	0 to 1	0	-	RW	No	Always	Yes
------	--------	---	---	----	----	--------	-----

This specifies the online gain tuning mode.

Settings	Setting details
0	Online gain tuning is not used.
1	Online gain tuning is used.

0x250E	System Rigidity for Gain Tuning						ALL
Variable type	Setting range	Initial value	Unit	Accessi bility	PDO assignme nt	Change attribute	Rete ntive
UINT	1 to 20	5	-	RW	No	Always	Yes

This specifies the system rigidity applied for gain tuning. After gain tuning according to the setting, the overall gain will be set higher or lower. If the gain of the maximum setting value is not enough, carry out the tuning manually. After gain tuning, the following gains will be changed automatically:

Inertia ratio (0x2100), position loop gain 1 (0x2001), speed loop gain 1 (0x2102), speed integral time constant 1 (0x2103), torque command filter time constant 1 (0x2104), notch filter 3 frequency (0x2507, TBD), and notch filter 4 frequency (0x250A, TBD).

0x250F	On-line Gain Tuning Adaptation Speed						ALL
Variable type	Setting range	Initial value	Unit	Accessi bility	PDO assignme nt	Change attribute	Rete ntive
UINT	1 to 5	1	-	RW	No	Always	Yes

This specifies the speed reflecting the change of gain when performing online gain tuning. The larger the setting value is, the faster the change of gain is reflected.

0x2510	Off-line Gain Tuning Direction						ALL
Variable type	Setting range	Initial value	Unit	Accessi bility	PDO assignme nt	Change attribute	Rete ntive
UINT	0 to 1	0	-	RW	No	Always	Yes

This specifies the movement direction when performing offline gain tuning. Set the function properly according to the condition of the apparatus section.

Settings	Setting details
0	Drive in the forward direction
1	Drive in the reverse direction

0x2511	Off-line Gain Tuning Distance						ALL
Variable type	Setting range	Initial value	Unit	Accessi bility	PDO assignme nt	Change attribute	Rete ntive
UINT	1 to 10	5	-	RW	No	Always	Yes

This specifies the distance when performing offline gain tuning. The larger the setting value is, the longer the moving distance becomes. Set the distance properly according to the condition of the apparatus section. Make sure to secure enough distance (more than one revolution of motor) prior to gain tuning.

0x2512	Disturbance Observer Gain						ALL
Variable type	Setting range	Initial value	Unit	Accessi bility	PDO assignme nt	Change attribute	Rete ntive
UINT	0 to 100	0	%	RW	No	Always	Yes

(Will be supported later.)

0x2513	Disturbance Observer Filter Time Constant						ALL
Variable type	Setting range	Initial value	Unit	Accessi bility	PDO assignme nt	Change attribute	Rete ntive
UINT	0 to 1000	10	0.1ms	RW	No	Always	Yes

(Will be supported later.)

0x2514	Current Controller Gain						ALL
Variable type	Setting range	Initial value	Unit	Accessi bility	PDO assignme nt	Change attribute	Rete ntive
UINT	1 to 150	100	%	RW	No	Always	Yes



This specifies the current controller gain. Lowering the setting value will reduce the noise, but the drive's responsiveness decreases as well.

0x2515	Vibration Supression Filter Configuration						ALL
Variable type	Setting range	Initial value	Unit	Accessi bility	PDO assignme nt	Change attribute	Rete ntive
UINT	0 to 5	0	-	RW	No	Always	Yes

Reserved

0x2516	Vibration Supression Filter 1 Frequency						ALL
Variable type	Setting range	Initial value	Unit	Accessi bility	PDO assignme nt	Change attribute	Rete ntive
UINT	0 to 2000	0	0.1Hz	RW	No	Always	Yes

Reserved

0x2517	Vibration Supression Filter 1 Damping						ALL
Variable type	Setting range	Initial value	Unit	Accessi bility	PDO assignme nt	Change attribute	Rete ntive
UINT	0 to 5	0	-	RW	No	Always	Yes

Reserved

0x2518	Vibration Supression Filter 2 Frequency						ALL
Variable type	Setting range	Initial value	Unit	Accessi bility	PDO assignme nt	Change attribute	Rete ntive
UINT	0 to 2000	0	0.1Hz	RW	No	Always	Yes

Reserved

0x2519	Vibration Supression Filter 2 Damping						ALL
Variable type	Setting range	Initial value	Unit	Accessi bility	PDO assignme nt	Change attribute	Rete ntive
UINT	0 to 5	0	-	RW	No	Always	Yes

Reserved

## ● Monitoring(0x2600~ )

0x2600	Feedback Speed						ALL
Variable type	Setting range	Initial value	Unit	Accessi bility	PDO assignme nt	Change attribute	Rete ntive
INT	-	-	rpm	RO	Yes	-	No

This represents the current rotation speed of the motor.

0x2601	Command Speed						ALL
Variable type	Setting range	Initial value	Unit	Accessi bility	PDO assignme nt	Change attribute	Rete ntive
INT	-	-	rpm	RO	Yes	-	No

This represents the speed command that is input to the speed control loop of the drive.

0x2602	Following Error						ALL
Variable type	Setting range	Initial value	Unit	Accessi bility	PDO assignme nt	Change attribute	Rete ntive
DINT	-	-	pulse	RO	Yes	-	No

This represents the position error of position control.

0x2603	Accumulated Operation Overload						ALL
Variable type	Setting range	Initial value	Unit	Accessi bility	PDO assignme nt	Change attribute	Rete ntive
INT	-	-	0.1%	RO	No	-	No

This represents the accumulated operation overload rate. When the value of the accumulated operation overload rate reaches the overload warning level setting (0x2010), the operation overload warning (W10) will occur; when it reaches 100%, the operation overload alarm (AL-21) will occur.

0x2604	Instantaneous Maximum Operation Overload						ALL
Variable type	Setting range	Initial value	Unit	Accessibility	PDO assignment	Change attribute	Retentive
INT	-	-	0.1%	RO	Yes	-	No

This represents the maximum value of the operation overload rate output instantaneously from the drive. This value can be initialized by the initialization of the instantaneous maximum operation overload.

0x2605	DC-Link Voltage DC-Link Voltage						ALL
Variable type	Setting range	Initial value	Unit	Accessibility	PDO assignment	Change attribute	Retentive
UINT	-	-	Volt	RO	Yes	-	No

This represents the DC link voltage by the main power input.

0x2606	Accumulated Regeneration Overload						ALL
Variable type	Setting range	Initial value	Unit	Accessibility	PDO assignment	Change attribute	Retentive
INT	-	-	0.1%	RO	No	-	No

This represents the accumulated overload rate of the regenerative resistor due to regenerative operation. If the value of the accumulated regenerative overload rate reaches 100%, a regenerative overload alarm (AL-23) will be generated.

0x2607	SingleTurn Data						ALL
Variable type	Setting range	Initial value	Unit	Accessibility	PDO assignment	Change attribute	Retentive
UDINT	-	-	pulse	RO	Yes	-	No

This represents the single-turn data of the motor. Values ranging from 0 to (encoder resolution-1) are displayed.

0x2608		Mechanical Angle					ALL
Variable type	Setting range	Initial value	Unit	Accessibility	PDO assignment	Change attribute	Retentive
UINT	-	-	0.1deg	RO	Yes	-	No

This represents the single-turn data of the motor, ranging from 0.0 to 359.9.

0x2609		Electrical Angle					ALL
Variable type	Setting range	Initial value	Unit	Accessibility	PDO assignment	Change attribute	Retentive
INT	-	-	0.1deg	RO	Yes	-	No

This represents the electrical angle of the motor, ranging from -180.0 to 180.0.

0x260A		MultiTurn Data					ALL
Variable type	Setting range	Initial value	Unit	Accessibility	PDO assignment	Change attribute	Retentive
DINT	-	-	rev.	RO	Yes	-	No

This represents the multi-turn data of the multi-turn encoder.

0x260B		Drive Temperature 1					ALL
Variable type	Setting range	Initial value	Unit	Accessibility	PDO assignment	Change attribute	Retentive
INT	-	-	°C	RO	No	-	No

This is the temperature measured by the temperature sensor integrated with the drive power board. If the measurement is higher than 95°C, the drive overheat alarm 1 (AL-22) will be generated.

0x260C		Drive Temperature 2					ALL
--------	--	---------------------	--	--	--	--	-----

Variable type	Setting range	Initial value	Unit	Accessibility	PDO assignment	Change attribute	Retentive
INT	-	-	°C	RO	No	-	No

This represents the temperature measured by the temperature sensor integrated with the drive control board. If the measured temperature is higher than 90°C, the drive overheat alarm 2 (AL-25) will be generated.

0x260D Encoder Temperature							
Variable type	Setting range	Initial value	Unit	Accessibility	PDO assignment	Change attribute	Retentive
INT	-	-	°C	RO	No	-	No

This represents the temperature measured by the temperature sensor integrated with the serial encoder provided by LS Mecapion (if the setting value of the encoder type (0x2001) is 4). If the measured temperature is higher than 90°C, the encoder overheat alarm (AL-26) will be generated.

0x260E Motor Rated Speed							
Variable type	Setting range	Initial value	Unit	Accessibility	PDO assignment	Change attribute	Retentive
UINT	-	-	rpm	RO	No	-	No

This represents the rated speed of the driving motor.

0x260F Motor Maximum Speed							
Variable type	Setting range	Initial value	Unit	Accessibility	PDO assignment	Change attribute	Retentive
UINT	-	-	rpm	RO	No	-	No

This represents the maximum speed of the driving motor.

0x2610 Drive Rated Current							
							ALL

Variable type	Setting range	Initial value	Unit	Accessibility	PDO assignment	Change attribute	Retentive
UINT	-	-	0.1A	RO	No	-	No

This represents the rated current of the drive.

0x2611	FPGA Version							ALL
Variable type	Setting range	Initial value	Unit	Accessibility	PDO assignment	Change attribute	Retentive	
STRING	-	-	-	RO	No	-	No	

This represents the FPGA version within the drive.

0x2612	Hall Signal Display							ALL
Variable type	Setting range	Initial value	Unit	Accessibility	PDO assignment	Change attribute	Retentive	
UINT	-	-	-	RO	No	-	No	

This represents the signal of the hall sensor installed in the encoder (or motor). This can be used to verify the connection status of the hall sensor signal or compare the U, V, W phases of the motor with the direction of the hall sensor signal.

The signal value is repeated in the order of 5→4→6→2→3→1 for a forward movement, while it is repeated in the order of 1→3→2→6→4→5 for a reverse movement.

Bit	Setting details
0	W-phase hall sensor signal
1	V-phase hall sensor signal
2	U-phase hall sensor signal

0x2613	Bootloader Version							ALL
Variable type	Setting range	Initial value	Unit	Accessibility	PDO assignment	Change attribute	Retentive	
STRING	-	-	-	RO	No	-	No	

This represents the bootloader version of the drive.

0x2614	Warning Code						ALL
Variable type	Setting range	Initial value	Unit	Accessi- bility	PDO assignme- nt	Change attribute	Rete- ntive
UINT	-	-	-	RO	Yes	-	No

This represents the warning code that has occurred in the drive.

0x2615	Analog Input Channel 1 Value						ALL
Variable type	Setting range	Initial value	Unit	Accessi- bility	PDO assignme- nt	Change attribute	Rete- ntive
INT	-	-	mV	RO	Yes	-	No

This displays the analog torque command input voltage in mV.

0x2616	Analog Input Channel 2 Value						ALL
Variable type	Setting range	Initial value	Unit	Accessi- bility	PDO assignme- nt	Change attribute	Rete- ntive
INT	-	-	mV	RO	Yes	-	No

This displays the analog speed override input voltage in mV.

0x2619	RMS Operation Overload						ALL
Variable type	Setting range	Initial value	Unit	Accessi- bility	PDO assignme- nt	Change attribute	Rete- ntive
INT	-	-	0.1%	RO	No	-	No

This displays the Root Mean Square (RMS) load factor for 15 seconds in 0.1% increments.



0x261D	Motor Temperature in Per Unit						ALL
Variable type	Setting range	Initial value	Unit	Accessibility	PDO assignment	Change attribute	Retentive
UINT	-	-	PU	R	Yes	-	-

This displays the motor temperature per unit. When it exceeds 100, the motor overheat (AL-27) alarm occurs.

The alarm generation time is calculated using the following formula:

$$T = \tau * \ln(I^2/(I^2-1)), \tau: \text{Thermal time constant of the motor, } I: \text{Motor load factor}$$

The alarm generation time for the motor load factor when T is 30 seconds is shown below.

Motor load factor (%)	Alarm generation time
110%	$1.75 * \tau = 52.54$
125%	$1.02 * \tau = 30.65$
150%	$0.59 * \tau = 17.63$
200%	$0.29 * \tau = 8.63$
250%	$0.17 * \tau = 5.23$
300%	$0.12 * \tau = 3.53$

0x261E	Load Encoder Position Feedback						ALL
Variable type	Setting range	Initial value	Unit	Accessibility	PDO assignment	Change attribute	Retentive
DINT	-	-	pulse	RO	No	-	-

This displays the position value of the load-side encoder in pulse units of the load encoder.

0x261F	Load Encoder Position Actual Internal Value						ALL
Variable type	Setting range	Initial value	Unit	Accessibility	PDO assignment	Change attribute	Retentive
DINT	-	-	UU	RO	No	-	-

This displays the position value of the load-side encoder in pulse units of the motor-side encoder considering the electronic gear ratio.

0x2620	Load Encoder Following Error						ALL
Variable type	Setting range	Initial value	Unit	Accessi- bility	PDO assignme- nt	Change attribute	Rete- ntive
DINT	-	-	pulse	RO	No	-	-

This displays the position difference between the load-side encoder and motor-side encoder in UU units.

0x2621	Load Encoder Velocity						ALL
Variable type	Setting range	Initial value	Unit	Accessi- bility	PDO assignme- nt	Change attribute	Rete- ntive
DINT	-	-	UU/s	RO	Yes	Always	No

This displays the speed of encoder 2 attached to the load side.

0x2622	Current RTC Time						ALL
Variable type	Setting range	Initial value	Unit	Accessi- bility	PDO assignme- nt	Change attribute	Rete- ntive
UDINT	-	-	-	RO	No	Always	Yes

This displays the current RTC time.

0x2623	Current RTC Date						ALL
Variable type	Setting range	Initial value	Unit	Accessi- bility	PDO assignme- nt	Change attribute	Rete- ntive
UDINT	-	-	-	RO	No	Always	Yes

This displays the current RTC date.

0x2624	Motor Encoder Status						ALL
Variable type	Setting range	Initial value	Unit	Accessi- bility	PDO assignme- nt	Change attribute	Rete- ntive

UINT	-	-	-	RO	No	Power cycling	Yes
------	---	---	---	----	----	---------------	-----

This displays the status of the first encoder, which is attached to the motor. Refer to the following for the statuses of the different encoder types.

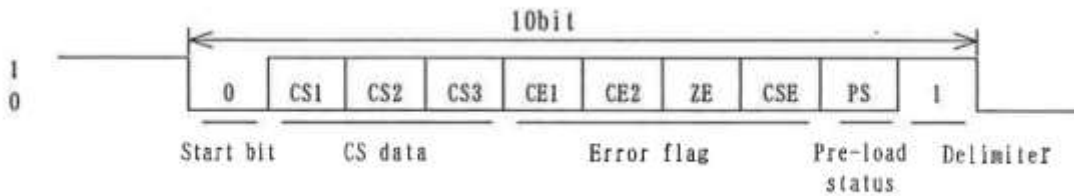

Fig.7 Format for status field

- ① Start bit: Fixed to "0".
- ② CS data: Commutation signals CS1-CS3
- ③ Error flag: Encoder error flag in case of error from "0" to "1"
- ④ Pre-load Status: Initial Z-signal non-detection signal in case of initial Z-signal detection from "1" to "0"
- ⑤ Delimiter: Fixed to "1".

TABLE 5. ALMC

Bit	d70	d71	d72	d73	d74	d75	d76	d77
Logic when each error occurs	1	1	1	1	---	1	1	1
Name & its symbol	Over-speed OS	Full absolute status FS	Counting error CE	Counter overflow OF	"0"	Multi-turn error ME	Battery error BE	Battery alarm BA

Table. 11 ALMC data assignment

Bit	d70	d71	d72	d73	d74	d75	d76	d77
Logic at error occurrence	"0"	"0"	"0"	"1"	"1"	"1"	"1"	"1"
Fixed name	Fixed	Fixed	Fixed	Count error 1 CE1	Count error 2 CE2	Z error ZE	CS error CSE	Pre-load status PS

- ① CE1: ABSA counter value is checked when Z-signal is detected.
- ② CE2: The number of pulses between CS phases is checked.
- ③ ZE: Z-output with the special value of ABSA counter is checked.
- ④ CSE: CS phase logic error.
- ⑤ PS: Initial Z-signal non-detection signal. (Pre-load status)

Refer to 5.4 for detail.

0x2625	Load Encoder Status						ALL
Variable type	Setting range	Initial value	Unit	Accessi- bility	PDO assignme- nt	Change attribute	Rete- ntive
UINT	-	-	-	RO	No	Power cycling	Yes

This displays the status of the second encoder, which is attached to the load side.

## ● Procedure and Alarm history(0x2700~ )

0x2700	Procedure Command Code						ALL
Variable type	Setting range	Initial value	Unit	Accessi bility	PDO assignme nt	Change attribute	Rete ntive
UINT	0 to 0xFFFF	0	-	RW	No	-	No

You can run various procedures with the following procedure command codes and command arguments. Make sure to enter the correct value for the command argument prior to entering command code because the drive refers to the command argument at the moment the command code is entered.

Command code	Command argument	Run procedure
Manual Jog (0x0001)	1	Servo on
	2	Servo off
	3	Positive (+) driving (0x2300)
	4	Negative (-) driving (0x2300)
	5	Stop to zero speed
Programmed Jog (0x0002)	1	Servo on
	2	Servo off
	3	Start operation
	4	Stop to zero speed (server on maintained)
Servo Alarm History Reset (0x0003)	1	
Offline Auto Tuning (0x0004)	1	Start auto tuning
Index Pulse Search (0x0005)	1	Servo on
	2	Servo off
	3	Positive (+) search (0x230C)
	4	Negative (-) search (0x230C)
	5	Stop to zero speed
Absolute Encoder Reset (0x0006)	1	Absolute encoder reset
Instantaneous Maximum Operation Overload Reset (0x0007)	1	Instantaneous maximum operation overload value reset (0x2604)

Phase Current Offset Tuning (0x0008)	1	Phase current offset tuning (The U, V, W phase offsets are stored in 0x2015 to 0x2017, respectively. If the offset is abnormally large, AL-15 will be generated.)
Software Reset (0x0009)	1	Software reset
Commutation (0x000A)	1	Commutation is performed

0x2701	Procedure Command Argument						ALL
Variable type	Setting range	Initial value	Unit	Accessi bility	PDO assignme nt	Change attribute	Rete ntive
UINT	0 to FFFF <sub>hex</sub>	0	-	RW	No	-	No

0x2702	Servo Alarm History						ALL
SubIndex 0		Number of entries					
Variable type	Setting range	Initial value	Unit	Accessi bility	PDO assignme nt	Change attribute	Rete ntive
STRING	-	16	-	RO	No	-	No
SubIndex 1		Alarm code 1 (Newest)					
Variable type	Setting range	Initial value	Unit	Accessi bility	PDO assignme nt	Change attribute	Rete ntive
STRING	-	-	-	RO	No	-	No
SubIndex 2		Alarm code 2					
Variable type	Setting range	Initial value	Unit	Accessi bility	PDO assignme nt	Change attribute	Rete ntive
STRING	-	-	-	RO	No	-	No
SubIndex 3		Alarm code 3					
Variable type	Setting range	Initial value	Unit	Accessi bility	PDO assignme nt	Change attribute	Rete ntive
STRING	-	-	-	RO	No	-	No

SubIndex 4		Alarm code 4					
Variable type	Setting range	Initial value	Unit	Accessi- bility	PDO assignme- nt	Change attribute	Rete- ntive
STRING	-	-	-	RO	No	-	No
SubIndex 5		Alarm code 5					
Variable type	Setting range	Initial value	Unit	Accessi- bility	PDO assignme- nt	Change attribute	Rete- ntive
STRING	-	-	-	RO	No	-	No
SubIndex 6		Alarm code 6					
Variable type	Setting range	Initial value	Unit	Accessi- bility	PDO assignme- nt	Change attribute	Rete- ntive
STRING	-	-	-	RO	No	-	No
SubIndex 7		Alarm code 7					
Variable type	Setting range	Initial value	Unit	Accessi- bility	PDO assignme- nt	Change attribute	Rete- ntive
STRING	-	-	-	RO	No	-	No
SubIndex 8		Alarm code 8					
Variable type	Setting range	Initial value	Unit	Accessi- bility	PDO assignme- nt	Change attribute	Rete- ntive
STRING	-	-	-	RO	No	-	No
SubIndex 9		Alarm code 9					
Variable type	Setting range	Initial value	Unit	Accessi- bility	PDO assignme- nt	Change attribute	Rete- ntive
STRING	-	-	-	RO	No	-	No
SubIndex 10		Alarm code 10					
Variable type	Setting range	Initial value	Unit	Accessi- bility	PDO assignme- nt	Change attribute	Rete- ntive
STRING	-	-	-	RO	No	-	No
SubIndex 11		Alarm code 11					
Variable type	Setting range	Initial value	Unit	Accessi- bility	PDO assignme- nt	Change attribute	Rete- ntive

					nt		
STRING	-	-	-	RO	No	-	No
SubIndex 12		Alarm code 12					
Variable type	Setting range	Initial value	Unit	Accessi bility	PDO assignme nt	Change attribute	Rete ntive
STRING	-	-	-	RO	No	-	No
SubIndex 13		Alarm code 13					
Variable type	Setting range	Initial value	Unit	Accessi bility	PDO assignme nt	Change attribute	Rete ntive
STRING	-	-	-	RO	No	-	No
SubIndex 14		Alarm code 14					
Variable type	Setting range	Initial value	Unit	Accessi bility	PDO assignme nt	Change attribute	Rete ntive
STRING	-	-	-	RO	No	-	No
SubIndex 15		Alarm code 15					
Variable type	Setting range	Initial value	Unit	Accessi bility	PDO assignme nt	Change attribute	Rete ntive
STRING	-	-	-	RO	No	-	No
SubIndex 16		Alarm code 16 (Oldest)					
Variable type	Setting range	Initial value	Unit	Accessi bility	PDO assignme nt	Change attribute	Rete ntive
STRING	-	-	-	RO	No	-	No

This represents the history of the servo alarms generated from the drive. Up to 16 recently generated servo alarms are stored. SubIndex 1 is the newest alarm while the SubIndex 16 is the oldest one out of the recently generated alarms. The servo alarm history can be reset by the procedure command.

0x2703	Servo Alarm History(Time, Date)						ALL
SubIndex 0		Number of entries					
Variable type	Setting range	Initial value	Unit	Accessi bility	PDO assignme nt	Change attribute	Rete ntive



					nt		
USINT	-	16	-	RO	No	-	No
SubIndex 1		Alarm 1 (Newest)					
Variable type	Setting range	Initial value	Unit	Accessi bility	PDO assignme nt	Change attribute	Rete ntive
ULINT	-	-	-	RO	No	-	No
SubIndex 2		Alarm 2					
Variable type	Setting range	Initial value	Unit	Accessi bility	PDO assignme nt	Change attribute	Rete ntive
ULINT	-	-	-	RO	No	-	No
SubIndex 3		Alarm 3					
Variable type	Setting range	Initial value	Unit	Accessi bility	PDO assignme nt	Change attribute	Rete ntive
ULINT	-	-	-	RO	No	-	No
SubIndex 4		Alarm 4					
Variable type	Setting range	Initial value	Unit	Accessi bility	PDO assignme nt	Change attribute	Rete ntive
ULINT	-	-	-	RO	No	-	No
SubIndex 5		Alarm 5					
Variable type	Setting range	Initial value	Unit	Accessi bility	PDO assignme nt	Change attribute	Rete ntive
ULINT	-	-	-	RO	No	-	No
SubIndex 6		Alarm 6					
Variable type	Setting range	Initial value	Unit	Accessi bility	PDO assignme nt	Change attribute	Rete ntive
ULINT	-	-	-	RO	No	-	No
SubIndex 7		Alarm 7					
Variable type	Setting range	Initial value	Unit	Accessi bility	PDO assignme nt	Change attribute	Rete ntive
ULINT	-	-	-	RO	No	-	No
SubIndex 8		Alarm 8					

Variable type	Setting range	Initial value	Unit	Accessi bility	PDO assignme nt	Change attribute	Rete ntive
ULINT	-	-	-	RO	No	-	No
SubIndex 9		Alarm 9					
Variable type	Setting range	Initial value	Unit	Accessi bility	PDO assignme nt	Change attribute	Rete ntive
ULINT	-	-	-	RO	No	-	No
SubIndex 10		Alarm 10					
Variable type	Setting range	Initial value	Unit	Accessi bility	PDO assignme nt	Change attribute	Rete ntive
ULINT	-	-	-	RO	No	-	No
SubIndex 11		Alarm 11					
Variable type	Setting range	Initial value	Unit	Accessi bility	PDO assignme nt	Change attribute	Rete ntive
ULINT	-	-	-	RO	No	-	No
SubIndex 12		Alarm 12					
Variable type	Setting range	Initial value	Unit	Accessi bility	PDO assignme nt	Change attribute	Rete ntive
ULINT	-	-	-	RO	No	-	No
SubIndex 13		Alarm 13					
Variable type	Setting range	Initial value	Unit	Accessi bility	PDO assignme nt	Change attribute	Rete ntive
ULINT	-	-	-	RO	No	-	No
SubIndex 14		Alarm 14					
Variable type	Setting range	Initial value	Unit	Accessi bility	PDO assignme nt	Change attribute	Rete ntive
ULINT	-	-	-	RO	No	-	No
SubIndex 15		Alarm 15					
Variable type	Setting range	Initial value	Unit	Accessi bility	PDO assignme nt	Change attribute	Rete ntive

ULINT	-	-	-	RO	No	-	No
SubIndex 16		Alarm 16 (Oldest)					
Variable type	Setting range	Initial value	Unit	Accessi- bility	PDO assignme- nt	Change attribute	Rete- ntive
ULINT	-	-	-	RO	No	-	No

This displays the time and date that a servo alarm was generated on the drive. Up to 16 generation times for the recently generated servo alarms are stored. SubIndex 1 is the newest alarm while the SubIndex 16 is the oldest one out of the recently generated alarms. The servo alarm history can be reset by the procedure command.

● **Third Party Motor Support(0x2800~ )**

The following motor parameters are provided to drive a motor manufactured by a third party in addition to our motor. To drive a third party's motor through our drive, you have to enter the correct parameters. In this case, however, our company has neither performed any tests for the combination of our drive and the third party motor nor gives any guarantees for the motor's characteristics.

0x2800	[Third Party Motor] Type						ALL
Variable type	Setting range	Initial value	Unit	Accessi bility	PDO assignme nt	Change attribute	Rete ntive
UINT	0 to 1	0	-	RW	No	Power cycling	Yes

This specifies the motor type.

Settings	Setting details
0	Rotary motor
1	Linear motor

0x2801	[Third Party Motor] Number of Poles						ALL
Variable type	Setting range	Initial value	Unit	Accessi bility	PDO assignme nt	Change attribute	Rete ntive
UINT	2 to 1000	8	-	RW	No	Power cycling	Yes

This specifies the number of motor poles. For a linear motor, set it to 2.

0x2802	[Third Party Motor] Rated Current						ALL
Variable type	Setting range	Initial value	Unit	Accessi bility	PDO assignme nt	Change attribute	Rete ntive
FP32	-	2.89	Arms	RW	No	Power cycling	Yes

This specifies the rated current of the motor.

0x2803	[Third Party Motor] Maximum Current						ALL
Variable type	Setting range	Initial value	Unit	Accessibility	PDO assignment	Change attribute	Retentive
FP32	-	8.67	Arms	RW	No	Power cycling	Yes

This specifies the maximum current of the motor.

0x2804	[Third Party Motor] Rated Speed						ALL
Variable type	Setting range	Initial value	Unit	Accessibility	PDO assignment	Change attribute	Retentive
UINT	1 to 60000	3000	rpm	RW	No	Power cycling	Yes

This specifies the rated speed of the motor. For a linear motor, the unit is mm/s.

0x2805	[Third Party Motor] Maximum Speed						ALL
Variable type	Setting range	Initial value	Unit	Accessibility	PDO assignment	Change attribute	Retentive
UINT	1 to 60000	5000	rpm	RW	No	Power cycling	Yes

This specifies the maximum speed of the motor. For a linear motor, the unit is mm/s.

0x2806	[Third Party Motor] Inertia						ALL
Variable type	Setting range	Initial value	Unit	Accessibility	PDO assignment	Change attribute	Retentive
FP32	-	0.321	Kg.m <sup>2</sup> . 10 <sup>-4</sup>	RW	No	Power cycling	Yes

This specifies the motor inertia. For a linear motor, set the weight of rotor. The unit is kg.

0x2807	[Third Party Motor] Torque Constant						ALL
Variable type	Setting range	Initial value	Unit	Accessi- bility	PDO assignme- nt	Change attribute	Rete- ntive
FP32	-	0.46	Nm/A	RW	No	Power cycling	Yes

This specifies the torque constant of a motor. For a linear motor, set the force constant. The unit is N/A.

0x2808	[Third Party Motor] Phase Resistance						ALL
Variable type	Setting range	Initial value	Unit	Accessi- bility	PDO assignme- nt	Change attribute	Rete- ntive
FP32	-	0.82	ohm	RW	No	Power cycling	Yes

This specifies the phase resistance (= resistance between lines ÷ 2) of the motor.

0x2809	[Third Party Motor] Phase Inductance						ALL
Variable type	Setting range	Initial value	Unit	Accessi- bility	PDO assignme- nt	Change attribute	Rete- ntive
FP32	-	3.66	mH	RW	No	Power cycling	Yes

This specifies the phase inductance (= inductance between lines ÷ 2) of the motor.

0x280A	[Third Party Motor] TN Curve Data 1						ALL
Variable type	Setting range	Initial value	Unit	Accessi- bility	PDO assignme- nt	Change attribute	Rete- ntive
UINT	1 to 60000	3000	rpm	RW	No	Power cycling	Yes

This specifies the data of the motor speed/torque curve. Enter the maximum speed at the time when the maximum torque ( the maximum thrust for a linear motor) is output. For a linear motor, the unit is mm/s.

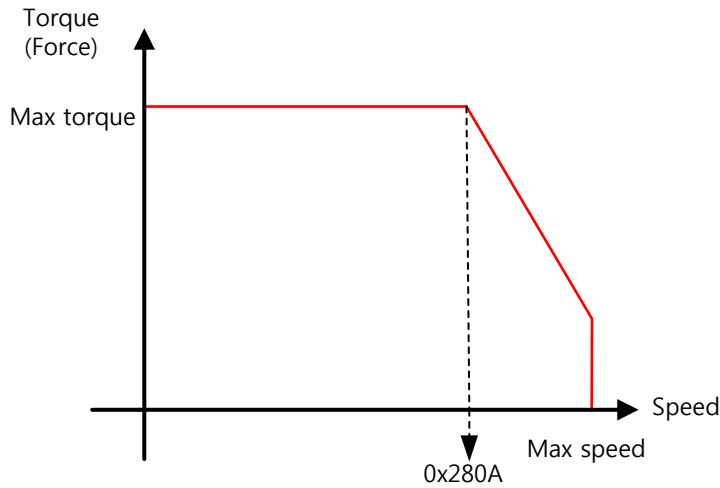

0x280B	[Third Party Motor] TN Curve Data 2						ALL
Variable type	Setting range	Initial value	Unit	Accessi bility	PDO assignme nt	Change attribute	Rete ntive
FP32	-	100.0	%	RW	No	Power cycling	Yes

This specifies the data of the motor speed/torque curve. Enter the torque (thrust for a linear motor), which can be output at the maximum speed as a percentage (%) relative to the maximum torque.

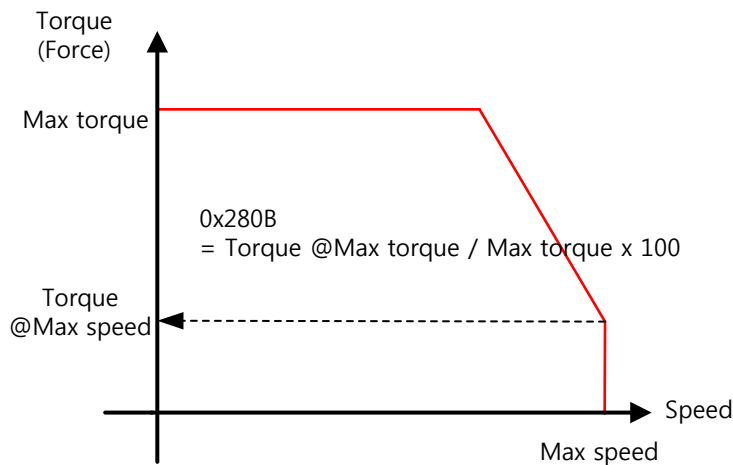

0x280C	[Third Party Motor] Hall Offset						ALL
Variable type	Setting range	Initial value	Unit	Accessi bility	PDO assignme nt	Change attribute	Rete ntive

UINT	0 to 360	0	deg	RW	No	Power cycling	Yes
------	----------	---	-----	----	----	---------------	-----

The offset of the hall sensor attached for the initial angle of a third party motor may vary depending on manufacturer. For this case, the hall sensor offset must be checked and correctly set.

[3rd Party Motor] Thermal Time Constant							
Variable type	Setting range	Initial value	Unit	Accessibility	PDO assignment	Change attribute	Retentive
FP32	-	32.77	°C /watt	RW	No	Power cycling	Yes

This sets the thermal time constant between motor winding and ambient temperature. If the motor heat prevention function is activated (0x2034 = 1), it estimates the motor temperature to generate a motor overheat (AL-27) alarm.

$$\text{Thermal time constant[sec]} = \text{Thermal resistance[°C/watt]} * \text{Thermal capacitance[watt-sec/°C]}$$

Motor Manufacturer							
Variable type	Setting range	Initial value	Unit	Accessibility	PDO assignment	Change attribute	Retentive
STRING	-	-	-	RW	No	Always	Yes

This specifies the motor manufacturer up to 32 characters.

Motor Model Name							
Variable type	Setting range	Initial value	Unit	Accessibility	PDO assignment	Change attribute	Retentive
STRING	-	-	-	RW	No	Always	Yes

This specifies the motor model up to 32 characters.





## 11.4 Index Objects

0x3000	Control Mode						ALL
Variable type	Setting range	Initial value	Unit	Accessi bility	Commun ication Address	Change attribute	Rete ntive
UINT	0 to 9	1	-	RW		Power cycling	Yes

This sets the position control mode for the drive.

Settings	Setting details
0	Indexing Position Mode
1	Pulse Input Position Mode
2	Velocity Mode
3	Torque Mode
4	Pulse input position operation & index position operation
5	Pulse input position operation & speed operation mode
6	Pulse input position operation & torque operation mode
7	Speed operation mode & torque operation mode
8	Index position operation mode & speed operation mode
9	Index position operation mode & torque operation mode

0x3001	Coordinate Select						ALL
Variable type	Setting range	Initial value	Unit	Accessi bility	Commun ication Address	Change attribute	Rete ntive
UINT	0 to 1	0	-	RW		Power cycling	Yes

This specifies a coordinate system to be used for the indexing position control of the drive.

Settings	Setting details
0	Uses linear coordinates
1	Uses rotary coordinates

0x3002	Baud Rate Select						ALL
Variable type	Setting range	Initial value	Unit	Accessi bility	PDO assignme nt	Change attribute	Rete ntive
UINT	0 to 3	3	-	RW	No	Power	Yes

						cycling	
--	--	--	--	--	--	---------	--

This sets the RS-422 serial communication speed between an upper-level controller and the drive.

Settings	Setting details
0	9600 [bps]
1	19200 [bps]
2	38400 [bps]
3	57600 [bps]

0x3003	Pulse Input Logic Select						ALL
Variable type	Setting range	Initial value	Unit	Accessi bility	PDO assignme nt	Change attribute	Rete ntive
UINT	0 to 5	0	-	RW	No	Power cycling	Yes

This specifies the logic of the pulse row received from the upper level controller. The type of input pulses and rotation direction per logic are as follows:

Settings	Setting details
0	A-phase + B-phase, positive logic
1	CW + CCW, positive logic
2	Pulse + sign, positive logic
3	A-phase + B-phase, negative logic
4	CW + CCW, negative logic
5	Pulse + sign, negative logic

0x3004	Pulse Input Filter Select						ALL
Variable type	Setting range	Initial value	Unit	Accessi bility	PDO assignme nt	Change attribute	Rete ntive
UINT	0 to 4	3	-	RW	No	Power cycling	Yes

This specifies the frequency band of the digital filter defined for the pulse input.

The determination of the frequency bands is based on the input pulse width in accordance with the digital filter's characteristics.

Settings	Setting details
0	Do not use any filter.

1	500Khz (Min)
2	750Khz
3	1Mhz
4	1.25Mhz

0x3005	PCLEAR Mode Select						ALL
Variable type	Setting range	Initial value	Unit	Accessi- bility	PDO assignme- nt	Change attribute	Rete- ntive
UINT	0 to 2	0	-	RW	No	Always	Yes

This specifies the operation mode when the position pulse clear (PCLR) signal is received.

Settings	Setting details
0	Operate in edge mode.
1	Operate in level mode (torque: Maintained).
2	Operate in level mode (torque: 0)

0x3006	Encoder Oupptut Pulse						ALL
Variable type	Setting range	Initial value	Unit	Accessi- bility	PDO assignme- nt	Change attribute	Rete- ntive
UDINT	0 to 2147483647	10000	pulse	RW	No	Power cycling	Yes

This specifies the pulse count to be output per motor rotation when the encoder signal is sent from the drive to the outside.

0x3007	Encoder Oupptut Mode						ALL
Variable type	Setting range	Initial value	Unit	Accessi- bility	PDO assignme- nt	Change attribute	Rete- ntive
UINT	0 to 1	0	-	RW	No	Power cycling	Yes

This specifies whether to output also in the open collector method in addition to the default line drive method when the servo outputs the encoder signal to the outside.

Settings	Setting details
0	Line drive only
1	Line drive + open collector

0x3008	Start Index Number(0~63)						ALL
Variable type	Setting range	Initial value	Unit	Accessi bility	PDO assignme nt	Change attribute	Rete ntive
UINT	0 to 64	0	-	RW	No	Always	Yes

This specifies the index number (0 - 63) for starting the Indexing Position operation.

If the selected value is 64, the index number is specified by ISEL0 - ISEL5.

0x3009	Index Buffer Mode						ALL
Variable type	Setting range	Initial value	Unit	Accessi bility	PDO assignme nt	Change attribute	Rete ntive
UINT	0 to 1	0	-	RW	No	Always	Yes

This specifies how many times the START (operation start) signal is remembered during the Indexing Position operation.

Settings	Setting details
0	Double buffer set
1	Single buffer set

0x300A	IOUT Configuration						ALL
Variable type	Setting range	Initial value	Unit	Accessi bility	PDO assignme nt	Change attribute	Rete ntive
UINT	0 to 5	0	-	RW	No	Always	Yes

This sets the IOUT output signal during the indexing position operation. Refer to the timing chart in 10.6.4 Functions of Index Output Signals.

Settings	Setting details
0	The IOUT signal is output during the indexing position operation. The completed IOUT signal is output after the indexing position operation is completed.
1	The previously completed IOUT signal is output during the indexing position operation. The completed IOUT signal is output after the indexing position operation is completed.
2	Reserved
3	Reserved

4	Reserved
5	Reserved

0x3100 ~ 0x313F	Index00 ~ Index63						
SubIndex 0		Number of entries					
Variable type	Setting range	Initial value	Unit	Accessibility	PDO assignment	Change attribute	Retentive
USINT	-	11	-	RO	No	-	No
SubIndex 1		Index Type					
Variable type	Setting range	Initial value	Unit	Accessibility	PDO assignment	Change attribute	Retentive
UINT	0 to 10	1	-	RW	No	Always	Yes
SubIndex 2		Distance					
Variable type	Setting range	Initial value	Unit	Accessibility	PDO assignment	Change attribute	Retentive
DINT	-2147483648 to 2147483647	100000	UU	RW	No	Always	Yes
SubIndex 3		Velocity					
Variable type	Setting range	Initial value	Unit	Accessibility	PDO assignment	Change attribute	Retentive
DINT	1 to 2147483647	100000	UU/s	RW	No	Always	Yes
SubIndex 4		Acceleration					
Variable type	Setting range	Initial value	Unit	Accessibility	PDO assignment	Change attribute	Retentive
DINT	1 to 2147483647	1000000	UU/s <sup>2</sup>	RW	No	Always	Yes
SubIndex 5		Deceleration					
Variable type	Setting range	Initial value	Unit	Accessibility	PDO assignment	Change attribute	Retentive
DINT	1 to 2147483647	1000000	UU/s <sup>2</sup>	RW	No	Always	Yes
SubIndex 6		Registration Distance					
Variable type	Setting range	Initial value	Unit	Accessibility	PDO assignment	Change attribute	Retentive
DINT	-2147483648 to 2147483647	100000	UU	RW	No	Always	Yes

SubIndex 7		Registration Velocity					
Variable type	Setting range	Initial value	Unit	Accessibility	PDO assignment	Change attribute	Retentive
DINT	1 to 2147483647	1000000	UU/s	RW	No	Always	Yes
SubIndex 8		Repeat Count					
Variable type	Setting range	Initial value	Unit	Accessibility	PDO assignment	Change attribute	Retentive
UINT	1 to 65535	1	-	RW	No	Always	Yes
SubIndex 9		Dwell Time					
Variable type	Setting range	Initial value	Unit	Accessibility	PDO assignment	Change attribute	Retentive
UINT	0 to 65535	200	ms	RW	No	Always	Yes
SubIndex 10		Next Index					
Variable type	Setting range	Initial value	Unit	Accessibility	PDO assignment	Change attribute	Retentive
UINT	0 to 63	1	-	RW	No	Always	Yes
SubIndex 11		Action					
Variable type	Setting range	Initial value	Unit	Accessibility	PDO assignment	Change attribute	Retentive
UINT	0 to 2	2	-	RW	No	Always	Yes

## 11.5 CiA402 Objects

0x603F	Error Code						ALL
Variable type	Setting range	Initial value	Unit	Accessi bility	PDO assignme nt	Change attribute	Rete ntive
UINT	-	0	-	RO	Yes	-	No

The last alarm code that occurred in the servo drive is displayed.

0x6040	Controlword						ALL
Variable type	Setting range	Initial value	Unit	Accessi bility	PDO assignme nt	Change attribute	Rete ntive
UINT	0 to 0xFFFF	0	-	RW	Yes	Always	No

This is composed of bits that control the drive state, the operation mode, and manufacturer-specific options.

Bit	Function	Description
0	Switch on	Refer to the description below of bits 0 to 3.
1	Enable Voltage	
2	Quick stop	
3	Enable operation	
4 to 6	Settings by operation mode	Refer to the description below of bits 4 to 9.
7	Fault reset	0→1: Alarm/warning reset
8	Halt	Refer to the description below of bits 4 to 9.
9	Settings by operation mode	
10	-	-
11 to 15	-	-

Description of bits 0 to 3

- Bits 0 to 3: Drive state control



Command	Controlword bit			
	Bit 3	Bit 2	Bit 1	Bit 0
Shutdown	–	1	1	0
Switch on	0	1	1	1
Switch on + Enable operation	1	1	1	1
Disable voltage	–	–	0	–
Quick stop	–	0	1	–
Disable operation	0	1	1	1
Enable operation	1	1	1	1

## Description of bits 4 to 9

- Bits 4, 5, 6, 8 and 9: For CSP, CSV, or CST mode operation

Bit	Function	Value	Description
4	–	0	-
5	–	0	-
6	–	0	-
8	Halt	0	Continues to perform the operation.
		1	Halts the operation according to the Halt Option code (0x605D).
9	–	0	-

- Bits 4, 5 and 9: For PP mode operation

Bit 9	Bit 5	Bit 4	Description
0	0	0 → 1	Proceeds to the next position when the operation at the current position is complete.
–	1	0 → 1	Drives to the next position immediately.
1	0	0 → 1	Drives from the current position to the profile position at the profile speed before it applies the next position.

- Bits 6 and 8: For PP mode operation

Bit	Function	Value	Description
6	Abs/rel	0	Sets the target position to an absolute value.

		1	Sets the target position to a relative value.
8	Halt	0	Runs an operation or continues an operation.
		1	Halts the operation according to the Halt Option code (0x605D).

- Bits 4, 5, 6, 8 and 9: For PV and PT mode operation

Bit	Function	Value	Description
4	–	0	Reserved
5	–	0	Reserved
6	–	0	Reserved
8	Halt	0	Continues to perform the operation.
		1	Halts the operation according to the Halt Option code (0x605D).
9	–	0	Reserved

- Bits 4, 5, 6, 8 and 9: For HM mode operation

Bit	Function	Value	Description
4	Homing Start	0	Does not perform the homing operation.
		1	Performs or is performing the homing operation.
5	–	0	-
6	–	0	-
8	Halt	0	Runs the bit 4 command.
		1	Halts the operation according to the Halt Option code (0x605D).
9	–	0	Reserved

0x6041	Statusword						ALL
Variable type	Setting range	Initial value	Unit	Accessi- bility	PDO assignme- nt	Change attribute	Rete- ntive
UINT	-	-	-	RO	Yes	-	No

Statusword indicates the current state of the drive. It consists of bits that indicate the state according to the drive and operation mode.

Bit	Function	Description
0	Ready to switch on	Refer to the description below of bits 0 to 7.
1	Switched on	
2	Operation enabled	
3	Fault	
4	Voltage enabled	
5	Quick stop	
6	Switch on disabled	
7	Warning	
8	–	Reserved
9	Remote	Processed as a Controlword (0x6040)
10	Operation mode specific	Refer to the description below of bits 10, 12 and 13.
11	Internal limit active	Refer to the description below of bit 11.
12 to 13	Operation mode specific	Refer to the description below of bits 10, 12 and 13.
14	ABS position valid	Refer to the description below of bit 14.
15	-	Reserved

#### Description of bits 0 to 7

- Bits 0 to 7: For the current state of the drive

Bit 7	Bit 6	Bit 5	Bit 4	Bit 3	Bit 2	Bit 1	Bit 0	Drive State
–	0	–	–	0	0	0	0	Not ready to switch on
–	1	–	–	0	0	0	0	Switch on disabled
–	0	1	–	0	0	0	1	Ready to switch on
–	0	1	–	0	0	1	1	Switched on
–	0	1	–	0	1	1	1	Operation enabled
–	0	0	–	0	1	1	1	Quick stop active
–	0	–	–	1	1	1	1	Fault reaction active
–	0	–	–	1	0	0	0	Fault
–	–	–	1	–	–	–	–	Main Power On
1	–	–	–	–	–	–	–	Warning is occurred

- Bits 10, 12 and 13: For CSP and CSV mode operation

Bit	State	Value	Description
10	Target reached	0	Unable to reach the target (position/velocity)
		1	Reached the target (position/velocity)
12	-	0	-
13	Following error	0	No position error (always 0 in Csv/Torque mode)
		1	Following error

- Bits 10, 12 and 13: For PP mode operation

Bit	State	Value	Description
10	Target reached	0	Halt (0x6040.8) = 0: Unable to reach the target position Halt (0x6040.8) = 1: deceleration
		1	Halt (0x6040.8) = 0: Reached the target position Halt (0x6040.8) = 1: Speed is 0
12	Set-point acknowledge	0	Prepares the previous set point and waits for a new set point.
		1	Changed from the previous set point to the new set point.
13	Following error	0	No following error
		1	Following error

- Bits 10, 12 and 13: For PV mode operation

Bit	State	Value	Description
10	Target reached	0	Halt (0x6040.8) = 0: Unable to reach the target speed Halt (0x6040.8) = 1: deceleration
		1	Halt (0x6040.8) = 0: Reached the target speed Halt (0x6040.8) = 1: Speed is 0
12	ZeroSpeed	0	Not in a zero speed state
		1	In a zero speed state
13	-	0	-

- Bits 10, 12 and 13: For homing mode operation

Bit 13	Bit 12	Bit 10	Description
Homing error	Homing attained	Target reached	

0	0	0	Homing in progress
0	0	1	Homing stopped or not started
0	1	0	Performed homing operation, but did not reach the target
0	1	1	Homing completed
1	0	0	Homing error; speed not equal to 0
1	0	1	Homing error; speed equal to 0

Description of bit 11

- Bit 11: Indicates whether to use an internal limit

Bit	State	Value	Description
11	Internal Limit Active	0	Not in software position limit status or does not use the software position limit function (0x2400).
		1	Software position limit status

Description of bit 14

- Bit 14: Absolute position valid

Bit	State	Value	Description
14	ABS Position Valid	0	Homing is not complete or an alarm related to the encoder has occurred.
		1	Homing is complete (applied when the drive is connected to EtherCAT communication).

0x605A	Quick Stop Option Code						ALL
Variable type	Setting range	Initial value	Unit	Accessi bility	PDO assignme nt	Change attribute	Rete ntive
INT	0 to 4	2	-	RW	No	Always	Yes

This sets the quick stop option code.

Settings	Description
0	Not used (transits into Switch On Disabled).
1	Slowly decelerates and then stops the drive according to the

	quick stop deceleration (0x6085) setting (Switch On Disabled)
2	Slowly decelerates and then stops the drive according to the quick stop deceleration (0x6085) setting (Switch On Disabled)
3	Stops using the torque limit value (Switch On Disabled)

0x605B	Shutdown Option Code						ALL
Variable type	Setting range	Initial value	Unit	Accessi bility	PDO assignme nt	Change attribute	Rete ntive
INT	0 to 1	0	-	RW	No	Always	Yes

This specifies the operation to shut down the servo drive (Operation Enabled state -> Ready to Switch On state).

Settings	Description
0	Not used
1	Decelerates to a stop; enters the Switch On Disabled state; enters the Ready state

0x605C	Disable Operation Option Code						ALL
Variable type	Setting range	Initial value	Unit	Accessi bility	PDO assignme nt	Change attribute	Rete ntive
INT	0 to 1	1	-	RW	No	Always	Yes

This specifies the Disable Operation state (Operation Enabled state → Switched On state) option code.

Settings	Description
0	Does not use the drive function.
1	Decelerates to a stop; moves to the Switch On Disabled state; moves to the Not Ready state

0x605D	Halt Option Code						ALL
Variable type	Setting range	Initial value	Unit	Accessi bility	PDO assignme nt	Change attribute	Rete ntive

					nt		
INT	0 to 4	0	-	RW	No	Always	Yes

The Halt option code sets the operation method used to move from the Operation Enabled state to the Switched On state.

Settings	Description
1	Decelerates to a stop; moves to the Operation Enabled state
2	Decelerates to a stop based on the quick stop deceleration time; move to the Operation Enabled state
3	Decelerates to a stop based on the torque limit; moves to the Operation Enabled state

0x605E	Fault Reaction Option Code						ALL
Variable type	Setting range	Initial value	Unit	Accessi- bility	PDO assignme- nt	Change attribute	Rete- ntive
INT	0	0	-	RW	No	Always	Yes

This sets the operation method that protects the drive system during fault reactions.

Settings	Description
0	Does not use the servo drive function. The motor will maintain the free-run state.

0x6060	Modes of Operation						ALL
Variable type	Setting range	Initial value	Unit	Accessi- bility	PDO assignme- nt	Change attribute	Rete- ntive
SINT	-1 to 10	-1	-	RW	Yes	Always	No

This sets the servo drive operation mode. The master sets the operation mode when the power is turned on.

This drive provides the following operation modes:

Settings	Name	Description
0	-	Mode not assigned
1	PP	Profile Position mode

2	-	Reserved
3	PV	Profile Velocity mode
4	PT	Profile Torque mode
6	HM	Homing mode
7	-	Reserved
8	CSP	Cyclic Synchronous Position mode
9	CSV	Cyclic Synchronous Velocity mode
10	CST	Cyclic Synchronous Torque mode
-1	-	Indexing Position
-2	-	Pulse Input Position
-3	-	Velocity
-4	-	Toqure
-5	-	Pulse Input Position & Indexing Position
-6	-	Pulse Input Position & Velocity
-7	-	Pulse Input Position & Toqure
-8	-	Velocity & Toqure
-9	-	Indexing Position & Velocity
-10	-	Indexing Position & Toqure
Other	-	Reserved

0x6061 Modes of Operation Display								ALL
Variable type	Setting range	Initial value	Unit	Accessi bility	PDO assignme nt	Change attribute	Rete ntive	
SINT	-	-	-	RO	Yes	-	No	

This displays the operation mode of the current drive.

0x6062 Position Demand Value								ALL
Variable type	Setting range	Initial value	Unit	Accessi bility	PDO assignme nt	Change attribute	Rete ntive	
DINT	-	-	UU	RO	Yes	-	No	

This displays the position demand value in the position units (UU) specified by the user.



0x6063	Position Actual Internal Value						ALL
Variable type	Setting range	Initial value	Unit	Accessi- bility	PDO assignme- nt	Change attribute	Rete- ntive
DINT	-	-	pulse	RO	Yes	-	No

This displays the actual internal position value in encoder pulses.

0x6064	Position Actual Value						ALL
Variable type	Setting range	Initial value	Unit	Accessi- bility	PDO assignme- nt	Change attribute	Rete- ntive
DINT	-	-	UU	RO	Yes	-	No

This displays the actual position value in user-defined position units (UU).

0x6065	Following Error Window						ALL
Variable type	Setting range	Initial value	Unit	Accessi- bility	PDO assignme- nt	Change attribute	Rete- ntive
UDINT	0 to 0x3FFFFFFF	600000	UU	RW	No	Always	Yes

This sets the position error range for checking the Following Error (AL-51).

Check the encoder resolution for the motor before motor operation and set the appropriate value.

E.g.) If the encoder pulse [0x2002] setting per parameter 1 rotation is 12000 and 3 motor rotations are set for the position error range, set to 36000.

0x6066	Following Error Timeout						ALL
Variable type	Setting range	Initial value	Unit	Accessi- bility	PDO assignme- nt	Change attribute	Rete- ntive
UINT	0 to 65535	0	ms	RW	No	Always	Yes

This specifies the timeout when checking the Following Error (AL-51).

0x6067	Position Window						ALL
Variable type	Setting range	Initial value	Unit	Accessi bility	PDO assignme nt	Change attribute	Rete ntive
UDINT	0 to 0x3FFFFFFF	100	UU	RW	No	Always	Yes

This specifies the position window for the target. If the position window range (0x6067) is maintained for the position window time (0x6068), the INPOS signal for Drive Status Output1 is output.

0x6068	Position Window Time						ALL
Variable type	Setting range	Initial value	Unit	Accessi bility	PDO assignme nt	Change attribute	Rete ntive
UINT	0 to 65535	0	ms	RW	No	Always	Yes

This sets the time it takes to reach the target position. If the position window range (0x6067) is maintained for the position window time (0x6068), the INPOS signal for Drive Status Output1 is output.

0x606B	Velocity Demand Value						ALL
Variable type	Setting range	Initial value	Unit	Accessi bility	PDO assignme nt	Change attribute	Rete ntive
DINT	-	-	UU/s	RO	Yes	-	No

This displays the output speed of the position controller or the command speed input to the speed controller.

0x606C	Velocity Actual Value						ALL
Variable type	Setting range	Initial value	Unit	Accessi bility	PDO assignme nt	Change attribute	Rete ntive

DINT	-	-	UU/s	RO	Yes	-	No
------	---	---	------	----	-----	---	----

This displays the actual velocity value in user-defined position units.

0x606D Velocity Window							
Variable type	Setting range	Initial value	Unit	Accessi- bility	PDO assignme- nt	Change attribute	Rete- ntive
UINT	0 to 65535	20000	UU/s	RW	No	Always	Yes

This specifies the velocity window. If the difference between the target speed and the actual speed remains within the velocity window (0x606D) for the velocity window time (0x606E), then the INSPD signal for Drive Status Output1 is output.

0x606E Velocity Window Time							
Variable type	Setting range	Initial value	Unit	Accessi- bility	PDO assignme- nt	Change attribute	Rete- ntive
UINT	0 to 65535	0	ms	RW	No	Always	Yes

This specifies the velocity window time. If the difference between the target speed and the actual speed remains within the velocity window (0x606D) for the velocity window time (0x606E), then the INSPD signal for Drive Status Output1 is output.

0x6071 Target Torque							
Variable type	Setting range	Initial value	Unit	Accessi- bility	PDO assignme- nt	Change attribute	Rete- ntive
INT	-5000 to 5000	0	0.1%	RW	Yes	Always	No

This specifies the target torque for the motor in 0.1% increments of the rated torque during torque control.

0x6072 Maximum Torque							
Variable type	Setting range	Initial value	Unit	Accessi- bility	PDO assignme- nt	Change attribute	Rete- ntive

UINT	0 to 5000	3000	0.1%	RW	Yes	Always	No
------	-----------	------	------	----	-----	--------	----

This sets the maximum torque that the motor can output in 0.1% increments of the rated torque.

0x6074 Torque Demand Value								ALL
Variable type	Setting range	Initial value	Unit	Accessi bility	PDO assignme nt	Change attribute	Rete ntive	
INT	-	-	0.1%	RO	Yes	-	No	

This displays the current torque demand value in 0.1% increments of the rated torque.

0x6076 Motor Rated Torque								ALL
Variable type	Setting range	Initial value	Unit	Accessi bility	PDO assignme nt	Change attribute	Rete ntive	
UINT	-	-	mNm	RO	Yes	-	No	

This displays the rated torque of the motor in mNm.

0x6077 Torque Actual Value								ALL
Variable type	Setting range	Initial value	Unit	Accessi bility	PDO assignme nt	Change attribute	Rete ntive	
INT	-	-	0.1%	RO	Yes	-	No	

This displays the actual torque value generated by the drive in 0.1% increments of the rated torque.

0x6078 Current Actual Value								ALL
Variable type	Setting range	Initial value	Unit	Accessi bility	PDO assignme nt	Change attribute	Rete ntive	
INT	-	-	0.1%	RO	Yes	-	No	

This displays the actual torque value generated by the drive in 0.1% increments of the rated torque. A value that is the same as the actual torque value [0x6077] is displayed.

0x6079	DC Link Circuit Voltage						ALL
Variable type	Setting range	Initial value	Unit	Accessibility	PDO assignment	Change attribute	Retentive
UINT	-	-	0.1V	RO	Yes	-	No

This displays the DC-link voltage supplied by the main power in 0.1 V units.

0x607C	Home Offset						ALL
Variable type	Setting range	Initial value	Unit	Accessibility	PDO assignment	Change attribute	Retentive
DINT	-536870912 to 536870911	0	UU	RW	No	Always	Yes

This sets the offset value for the origin of the absolute encoder or absolute external scale and the zero position of the actual position value (0x6064).

- Incremental Encoder

If it finds the home position or it is at the home position, then the position moved by the home offset value becomes the zero position.

- Absolute Encoder

If the absolute encoder is connected, then the home offset value is added to the absolute position (the actual position value).

0x607D	Software Position Limit						
SubIndex 0			Number of entries				
Variable type	Setting range	Initial value	Unit	Accessibility	PDO assignment	Change attribute	Retentive
USINT	-	2	-	RO	No	-	No
SubIndex 1			Min position limit				
Variable	Setting range	Initial value	Unit	Accessibility	PDO	Change	Retentive

type				ty	assignment	attribute	e
DINT	-1073741824 to 1073741823	-1000000000	UU	RW	No	Always	Yes
SubIndex 2		Max position limit					
Variable type	Setting range	Initial value	Unit	Accessibili ty	PDO assignment	Change attribute	Retentiv e
DINT	-1073741824 to 1073741823	1000000000	UU	RW	No	Always	Yes

This specifies the software position limit value. It limits the range of the position demand value (0x6062) and actual position value (0x6064) and checks the new target positions for the setting value at every cycle.

The minimum software limit value is the reverse rotation limit. The maximum software limit value is the forward rotation limit.

0x607F	Max Profile Velocity						ALL
Variable type	Setting range	Initial value	Unit	Accessi bility	PDO assignme nt	Change attribute	Rete ntive
UDINT	0 to 0x7FFFFFFF	0x7FFFFFFF	UU/s	RW	Yes	Always	Yes

This specifies the maximum profile speed for the PP mode operation.

0x6080	Max Motor Speed						ALL
Variable type	Setting range	Initial value	Unit	Accessi bility	PDO assignme nt	Change attribute	Rete ntive
UDINT	-	-	RPM	RO	Yes	Always	Yes

This represents the maximum speed of the motor.

0x6081	Profile Velocity						ALL
Variable	Setting range	Initial	Unit	Accessi	PDO	Change	Rete

type		value		bility	assignme nt	attribute	ntive
UDINT	0 to 0x7FFFFFFF	200000	UU/s	RW	Yes	Always	Yes

This specifies the profile speed for the PP mode operation.

0x6083	Profile Acceleration							ALL
Variable type	Setting range	Initial value	Unit	Accessi bility	PDO assignme nt	Change attribute	Rete ntive	
UDINT	0 to 0x7FFFFFFF	200000	UU/s <sup>2</sup>	RW	No	Always	Yes	

This specifies the profile acceleration for the PP mode operation.

0x6084	Profile Deceleration							ALL
Variable type	Setting range	Initial value	Unit	Accessi bility	PDO assignme nt	Change attribute	Rete ntive	
UDINT	0 to 0x7FFFFFFF	200000	UU/s <sup>2</sup>	RW	No	Always	Yes	

This specifies the profile deceleration for the PP mode operation.

0x6085	Quick Stop Deceleration							ALL
Variable type	Setting range	Initial value	Unit	Accessi bility	PDO assignme nt	Change attribute	Rete ntive	
UDINT	0 to 0x7FFFFFFF	200000	UU/s <sup>2</sup>	RW	No	Always	Yes	

The system uses quick stop deceleration if the quick stop option code (0x605A) is set to 2.

0x6087	Torque Slope							ALL
Variable type	Setting range	Initial value	Unit	Accessi bility	PDO assignme nt	Change attribute	Rete ntive	

UDINT	0 to 0x7FFFFFFF	1000	0.1%/s	RW	Yes	Always	Yes
-------	-----------------	------	--------	----	-----	--------	-----

This specifies the torque slope for the PT mode operation.

0x6091	Gear Ratio						
SubIndex 0		Number of entries					
Variable type	Setting range	Initial value	Unit	Accessibility	PDO assignment	Change attribute	Retentive
USINT	-	2	-	RO	No	-	No
SubIndex 1		Motor revolutions					
Variable type	Setting range	Initial value	Unit	Accessibility	PDO assignment	Change attribute	Retentive
UDINT	0 to 0x40000000	1	-	RW	No	Power cycling	Yes
SubIndex 2		Shaft revolutions					
Variable type	Setting range	Initial value	Unit	Accessibility	PDO assignment	Change attribute	Retentive
UDINT	0 to 0x40000000	1	-	RW	No	Power cycling	Yes

For more information, refer to 10.3 Electric Gear Setup.

0x6098	Homing Method							ALL
Variable type	Setting range	Initial value	Unit	Accessibility	PDO assignment	Change attribute	Retentive	
SINT	-128 to 127	34	-	RW	No	Always	Yes	

This sets the homing method. For more information, refer to 9.1 Homing.

Settings	Description
0	Disabled
1	Homing using the index pulse and reverse limit contact
2	Homing using the index pulse and forward limit contact
7 to 14	Homing using the index pulse and home contact
24	Same as method 8 (does not use the index pulse)
28	Same as method 12 (does not use the index pulse)
33, 34	Homing to the index pulse
35	Homing to the current position



-1	Homing using the negative stopper and index pulse
-2	Homing using the positive stopper and index pulse
-3	Homing using the negative stopper only
-4	Homing using the positive stopper only

0x6099		Homing Speeds						
SubIndex 0		Number of entries						
Variable type	Setting range	Initial value	Unit	Accessibili ty	PDO assignment	Change attribute	Retentiv e	
USINT	-	2	-	RO	No	-	No	
SubIndex 1		Speed during search for switch						
Variable type	Setting range	Initial value	Unit	Accessibili ty	PDO assignment	Change attribute	Retentiv e	
DINT	0 to 0x40000000	500000	UU/s	RW	No	Always	Yes	
SubIndex 2		Speed during search for zero						
Variable type	Setting range	Initial value	Unit	Accessibili ty	PDO assignment	Change attribute	Retentiv e	
DINT	0 to 0x40000000	100000	UU/s	RW	No	Always	Yes	

This specifies the operation speed for homing.

0x609A		Homing Acceleration					ALL
Variable type	Setting range	Initial value	Unit	Accessi bility	PDO assignme nt	Change attribute	Rete ntive
UDINT	0 to 0x40000000	200000	UU/s <sup>2</sup>	RW	No	Always	Yes

This specifies the operation acceleration for homing.

0x60B0		Position Offset					ALL
Variable type	Setting range	Initial value	Unit	Accessi bility	PDO assignme nt	Change attribute	Rete ntive
DINT	-2147483648 to 2147483647	0	UU	RW	Yes	Always	No

In CSP mode, this specifies the offset value added to the position command.

0x60B1		Velocity Offset					ALL
Variable type	Setting range	Initial value	Unit	Accessi- bility	PDO assignme- nt	Change attribute	Rete- ntive
DINT	-2147483648 to 2147483647	0	UU/s	RW	Yes	Always	No

In position control, this corresponds to the speed feedforward value.

0x60B2		Torque Offset					ALL
Variable type	Setting range	Initial value	Unit	Accessi- bility	PDO assignme- nt	Change attribute	Rete- ntive
INT	-5000 to 5000	0	0.1%	RW	Yes	Always	No

In position control, this corresponds to the torque feedforward value.

0x60B8		Touch Probe Function					ALL
Variable type	Setting range	Initial value	Unit	Accessi- bility	PDO assignme- nt	Change attribute	Rete- ntive
UINT	0 to 0xFFFF	0x0033	-	RW	Yes	Always	No

This sets the touch probe function.

Bit	Value	Description
0	0	Does not use touch probe 1.
	1	Uses touch probe 1.
1	0	Single trigger mode
	1	Continuous trigger mode
2	0	Triggered by the input of touch probe 1.
	1	Triggered by the index pulse signal.
3	-	Reserved
4	0	Does not capture the rising edge position value of touch

		probe 1.
	1	Captures the rising edge position value of touch probe 1.
5	0	Does not capture the falling edge position value of touch probe 1.
	1	Captures the falling edge position value of touch probe 1.
6 to 7	–	Reserved
8	0	Does not use touch probe 2.
	1	Uses touch probe 2.
9	0	Single trigger mode
	1	Continuous trigger mode
10	0	Triggered by the input of touch probe 2.
	1	Triggered by the index pulse signal.
11	–	Reserved
12	0	Does not capture the rising edge position value of touch probe 2.
	1	Captures the rising edge position value of touch probe 2.
13	0	Does not capture the falling edge position value of touch probe 2.
	1	Captures the falling edge position value of touch probe 2.
14 to 15	–	Reserved

0x60B9	Touch Probe Status						ALL
Variable type	Setting range	Initial value	Unit	Accessibility	PDO assignment	Change attribute	Retentive
UINT	-	-	-	RO	Yes	-	No

This displays the status of the touch probe.

Bit	Value	Description
0	0	Does not use touch probe 1.
	1	Uses touch probe 1.
1	0	Does not store the rising edge position value of touch probe 1.
	1	Stores the rising edge position value of touch probe 1.
2	0	Does not store the falling edge position value of touch probe 1.

	1	Stores the falling edge position value of touch probe 1.
3 to 5	–	Reserved
6	0, 1	Toggles when the rising edge position value of touch probe 1 is updated.
7	0, 1	Toggles when the falling edge position value of touch probe 1 is updated.
8	0	Does not use touch probe 2.
	1	Uses touch probe 2.
9	0	Does not store the rising edge position value of touch probe 2.
	1	Stores the rising edge position value of touch probe 2.
10	0	Does not store the falling edge position value of touch probe 2.
	1	Stores the falling edge position value of touch probe 2.
11 to 13	–	Reserved
14	0, 1	Toggles when the rising edge position value of touch probe 2 is updated.
15	0, 1	Toggles when the falling edge position value of touch probe 2 is updated.

In continuous trigger mode, you can toggle to save all update values for bits 6, 7, 14 and 15 on the rising/falling edge of the touch probe. To disable bits 1, 2, 9 and 10 (saving the position values on the rising/falling edges of touch probes 1 and 2) of the touch probe state (0x60B9), disable bits 4, 5, 12 and 13 (by sampling the rising/falling edges of touch probes 1 and 2) of the touch probe function (0x60B8) and enable them.

0x60BA	Touch Probe 1 Positive Edge Position Value						ALL
Variable type	Setting range	Initial value	Unit	Accessi bility	PDO assignme nt	Change attribute	Rete ntive
DINT	-	-	UU	RO	Yes	-	No

This represents the rising edge position value of touch probe 1.

0x60BB	Touch Probe 1 Negative Edge Position Value						ALL
Variable	Setting range	Initial	Unit	Accessi	PDO	Change	Rete

type		value		bility	assignme nt	attribute	ntive
DINT	-	-	UU	RO	Yes	-	No

This represents the falling edge position value of touch probe 1.

0x60BC	Touch Probe 2 Positive Edge Position Value							ALL
Variable type	Setting range	Initial value	Unit	Accessi bility	PDO assignme nt	Change attribute	Rete ntive	
DINT	-	-	UU	RO	Yes	-	No	

This represents the rising edge position value of touch probe 2.

0x60BD	Touch Probe 2 Negative Edge Position Value							ALL
Variable type	Setting range	Initial value	Unit	Accessi bility	PDO assignme nt	Change attribute	Rete ntive	
DINT	-	-	UU	RO	Yes	-	No	

This represents the falling edge position value of touch probe 2.

0x60E0	Positive Torque Limit Value							ALL
Variable type	Setting range	Initial value	Unit	Accessi bility	PDO assignme nt	Change attribute	Rete ntive	
UINT	0 to 5000	3000	0.1%	RW	Yes	Always	Yes	

This sets the limit for the forward torque values.

0x60E1	Negative Torque Limit Value							ALL
Variable type	Setting range	Initial value	Unit	Accessi bility	PDO assignme nt	Change attribute	Rete ntive	
UINT	0 to 5000	3000	0.1%	RW	Yes	Always	Yes	

This sets the limit for the reverse torque values.

0x60F4	Following Error Actual Value						ALL
Variable type	Setting range	Initial value	Unit	Accessi bility	PDO assignme nt	Change attribute	Rete ntive
DINT	-	-	UU	RO	Yes	-	No

This displays the actual position error during position control.

0x60FC	Position Demand Internal Value						ALL
Variable type	Setting range	Initial value	Unit	Accessi bility	PDO assignme nt	Change attribute	Rete ntive
DINT	-	-	pulse	RO	Yes	-	No

This represents the value entered as the command during position control.

0x60FD	Digital Inputs						ALL
Variable type	Setting range	Initial value	Unit	Accessi bility	PDO assignme nt	Change attribute	Rete ntive
UDINT	-	-	-	RO	Yes	-	No

They indicate the status of digital inputs.

Bit	Description
0	NOT (negative limit switch)
1	POT (positive limit switch)
2	HOME (origin sensor input)
3 to 15	Reserved
16	DI #1(I/O pin 12), 0:Open, 1:Close
17	DI #2(I/O pin 13), 0:Open, 1:Close
18	DI #3(I/O pin 14), 0:Open, 1:Close
19	DI #4(I/O pin 15), 0:Open, 1:Close
20 to 30	Reserved
31	Reserved

0x60FE		Digital Outputs					
SubIndex 0		Number of entries					
Variable type	Setting range	Initial value	Unit	Accessibility	PDO assignment	Change attribute	Retentive
USINT	-	2	-	RO	No	-	No
SubIndex 1		Physical outputs					
Variable type	Setting range	Initial value	Unit	Accessibility	PDO assignment	Change attribute	Retentive
UDINT	0 to 0xFFFFFFFF	0	-	RW	Yes	Always	No
SubIndex 2		Bit mask					
Variable type	Setting range	Initial value	Unit	Accessibility	PDO assignment	Change attribute	Retentive
UDINT	0 to 0xFFFFFFFF	0	-	RW	Yes	Always	Yes

They indicate the status of digital outputs.

- Description of physical outputs

Bit	Description
0 to 15	Reserved
16	Forced output (0: OFF, 1: ON) of DO #1 (I/O pins 35 and 36) Provided that the relevant bit mask (0x60FE:02.16) is set to 1.
17	Forced output (0: OFF, 1: ON) of DO #2 (I/O pins 37 and 38) Provided that the relevant bit mask (0x60FE:02.17) is set to 1.
18	Forced output (0: OFF, 1: ON) of DO #3 (I/O pins 39 and 40) Provided that the relevant bit mask (0x60FE:02.18) is set to 1.
19	Forced output (0: OFF, 1: ON) of DO #4 (I/O pins 41 and 42) Provided that the relevant bit mask (0x60FE:02.19) is set to 1.
20 to 23	Reserved
24	Output status of DO #1 (0: OFF, 1: ON)
25	Output status of DO #2 (0: OFF, 1: ON)
26	Output status of DO #3 (0: OFF, 1: ON)
27	Output status of DO #4 (0: OFF, 1: ON)
28 to 31	Reserved

- Description of bit mask

Bit	Description
0 to 15	Reserved
16	Forced output setting (0: Disable, 1: Enable) of DO #1 (I/O pins 35 and 36)
17	Forced output setting (0: Disable, 1: Enable) of DO #2 (I/O pins 37 and 38)
18	Forced output setting (0: Disable, 1: Enable) of DO #3 (I/O pins 39 and 40)
19	Forced output setting (0: Disable, 1: Enable) of DO #4 (I/O pins 41 and 42)
20 to 31	Reserved

0x60FF	Target Velocity						ALL
Variable type	Setting range	Initial value	Unit	Accessability	PDO assignment	Change attribute	Retentive
DINT	-2147483648 to 2147483647	0	UU/s	RW	Yes	Always	No

This specifies the target velocity in PV mode and CSV mode.

0x6502	Supported Drive Modes						ALL
Variable type	Setting range	Initial value	Unit	Accessability	PDO assignment	Change attribute	Retentive
UDINT	-	0x000003AD	-	RO	No	-	No

This displays the mode(s) supported by the drive.

Bit	Supported modes	Description
-1	IP (Indexing Position/Pulse Input Position)	1: Supported
0	PP (Profile Position)	0: Not supported
1	VI (Velocity)	0: Not supported
2	PV (Profile Velocity)	0: Not supported
3	PT (Torque Profile)	0: Not supported
4	Reserved	0
5	HM (Homing)	1: Supported
6	IP (Interpolated Position)	0: Not Supported



7	CSP (Cyclic Synchronous Position)	0: Not supported
8	CSV (Cyclic Synchronous Velocity)	0: Not supported
9	CST (Cyclic Synchronous Torque)	0: Not supported
10 to 31	Reserved	0





# 12. Maintenance and Inspection

## 12.1 Diagnosing and Troubleshooting Abnormalities





Alarms or warnings are generated if a problem occurs during operation. If this happens, check the applicable code and take appropriate action. If the problem persists, contact our service center.





## 12.2 Servo Alarm

If the drive detects a problem, it will trigger a servo alarm and transition to the servo off state to stop. In this case, the value of the emergency stop setting (0x2013) is used to stop the drive.

Alarm code name	Cause	Check list	Troubleshooting
 IPM fault (Overcurrent (Hardware))   Over current (Overcurrent (Software))   Current limit exceeded (Overcurrent (Hardware))	Motor cable failure	Check for wiring failure and short-circuits.	Replace the motor cable.
	Encoder cable failure	Check for wiring failure and short-circuits.	Replace the encoder cable.
	Parameter setting failure	Motor ID [0x2000], encoder type [0x2001], encoder type [0x2002], and third party parameter [0x2800~] settings should be the same as the motor information.	Modify the parameters so they match the motor information.
	Motor phase resistance failure	Inspect resistance between motor lines (U-V, V-W, W-U below several Ω)	Replace the motor.
	Apparatus status failure	Determine whether there is any conflict or restraint in the equipment.	Inspect the apparatus.
	Drive failure		If an alarm occurs continuously after power cycling, there may be a problem with the drive. Replace the drive.

Alarm code name	Cause	Check list	Troubleshooting
	Failure due to noise	Find a way to resolve the noise problem by checking the wiring and installation.	Check the FG wiring status. Adjust the FG wiring size so that it matches the size of the drive main circuit wiring.
 IPM temperature (IPM Overheat)	Ambient temperature	Check whether the ambient temperature is over 50 °C.	Lower the temperature around the drive.
	Continuous overload alarm	Check whether the load is below 100% in the accumulated drive overload rate [0x2603].	Change the capacity of the drive and motor. Adjust the gain.
	High-frequency regenerative operation or continuous regenerative operation	Check the accumulated regenerative overload rate [0x2606].	Adjust the regenerative resistance setting [0x2009]. Use the external regenerative resistance.
	Drive installation direction	Check the drive installation status.	Refer to Chapter 2. Wiring and Connection.
	Drive failure		If an alarm occurs continuously after power cycling, there may be a problem with the drive. Replace the drive.
 Current offset (Abnormal Current Offset)	Excessive current offset in motor U-phase and V-phase	Check whether the U, V, W phase current offsets [0x2015] - [0x2017] are 5% of the rated current or higher.	Adjust the phase current offset again.
	Drive failure		If an alarm occurs continuously after adjusting the phase current offset, there may be a problem with the drive. Replace the drive.
 Continuous overload (Continuous Overload)	The drive operates continuously, exceeding the rated load.	Continuous operation in the constant speed area or in the stopped state Check whether the load is below 100% in the load rate [0x2603].	Change the capacity of the drive and motor. Adjust the gain.
	Motor brake failure	Check whether the motor brake is open at SVON.	Supply power to the motor brake.

Alarm code name	Cause	Check list	Troubleshooting
	Parameter setting failure	Motor ID [0x2000], encoder type [0x2001], encoder type [0x2002], and third party parameter [0x2800~] settings should be the same as the motor information.	Modify the parameters so they match the motor information.
		Check the overload detection default load rate setting [0x200F].	Set it to an appropriate value.
	Apparatus status failure	Operation should be normal.	Inspect the apparatus.
	Motor cable failure	Check for wiring failure and short-circuits.	Replace the motor cable.
	Encoder cable failure	Check for wiring failure and short-circuits.	Replace the encoder cable.
 Drive temperature 1 (Drive Overheat 1)	Ambient temperature	Check whether the ambient temperature is over 50 °C.	Lower the temperature around the drive.
	Drive failure	In normal conditions, check if the drive temperature 1 [0x260B] is significantly different from the ambient temperature.	Replace the drive.
 Motor cable open (Motor Disconnection)	Motor cable failure	Check the cable disconnection.	Replace the motor cable.
	Motor failure	Check for a U, V, or W short-circuit in the motor. (U-V, V-W, W-U)	Replace the motor.
	Drive failure		If an alarm occurs continuously after SVON ON, there may be a problem with the drive. Replace the drive.
 Drive temperature 2 (Drive Overheat 2)	Ambient temperature	Check whether the ambient temperature is over 50 °C.	Lower the temperature around the drive.
	Drive failure	In normal conditions, check if the drive temperature 2 [0x260C] is significantly different from the ambient temperature.	Replace the drive.
 Encoder temperature (Encoder Overheat)	Reserved		
 Encoder	Encoder cable failure	Check for disconnection, wiring failure, or short-circuits.	Replace the encoder cable.





Alarm code name	Cause	Check list	Troubleshooting
communication (Serial Encoder Communication Error)   Encoder cable open (Encoder Cable Disconnection)   Encoder data (Encoder Data Error)   Encoder setting (Encoder Setting Error)	Parameter setting failure	Motor ID [0x2000], encoder type [0x2001], encoder type [0x2002], and third party parameter [0x2800~] settings should be the same as the motor information.	Modify the parameters so they match the motor information.
	Encoder failure		If an alarm occurs continuously after power cycling, there may be a failure in the motor. Replace the motor.
	Drive failure		If an alarm occurs continuously after power cycling, there may be a problem with the drive. Replace the drive.
 Motor setting (Motor ID Setting Error)	Motor ID setting	The [0x2000] setting should be the same as the motor label information.	Modify the parameter so it matches the motor label information. The alarm can be deactivated by turning off and on the power after modifying the parameter.
	Drive failure		If an alarm occurs continuously after power cycling, there may be a problem with the drive. Replace the drive.
 Z phase open (Encoder Z-phase Disconnection)	Encoder cable failure	Check for wiring failure or short-circuits.	Replace the encoder cable.
	Encoder failure		If an alarm occurs continuously after power cycling, there may be a failure in the motor. Replace the motor.
	Drive failure		If an alarm occurs continuously after power cycling, there may be a problem with the drive. Replace the drive.

Alarm code name	Cause	Check list	Troubleshooting	
<b>AL-35</b> Low battery (Low Voltage of Encoder Battery)	Parameter setting failure	Check the [0x2005] setting.	If you want to use an absolute encoder as an incremental encoder, set it to 1 so the alarm does not occur.	
	Battery connection failure or no connection	Check the battery connection status.	Properly connect the battery.	
	The battery voltage is low	Check whether the battery voltage is 3.3 V or higher.	Replace the battery.	
<b>AL-36</b> Sinusoidal ENC amplitude (Encoder Sine Wave Amplitude Error)	Encoder cable failure	Check for disconnection, wiring failure, or short-circuits.	Replace the encoder cable.	
	Drive failure		If an alarm occurs continuously after power cycling, there may be a problem with the drive. Replace the drive.	
	<b>AL-37</b> Sinusoidal ENC frequency (Encoder Sine Wave Frequency Error)	Resolver failure		If an alarm occurs continuously after power cycling, there may be a problem with the resolver. Replace the resolver.
		Encoder failure		If an alarm occurs continuously after power cycling, there may be a failure in the motor. Replace the motor.
<b>AL-40</b> Under voltage (Low Voltage) *The alarm occurs when SVON is on.	Main power input voltage failure	Check whether the main power voltage is DC 24 V or higher.	Inspect the power again.	
		Check whether the [0x2605] value is 24 - 80 V while the main power is being applied normally.	Replace the drive.	
	Parameter setting failure	Check the undervoltage fault level [0x2032] setting.	Set parameters suitable for the main power input status.	
<b>AL-41</b> Over voltage (Overvoltage)	Main power input voltage failure	Check whether the main power voltage is DC 90 V or lower.	Inspect the power again.	
		Check whether the [0x2605] value is 24 - 80 V while the main power is	Replace the drive.	

Alarm code name	Cause	Check list	Troubleshooting
		being applied normally.	
	Parameter setting failure	Check the undervoltage fault level [0x2032] setting.	Set parameters suitable for the main power input status.
	Acceleration/Deceleration settings	When acceleration/deceleration is frequent	Set a long acceleration/deceleration time.
	Drive failure		If an alarm occurs continuously after power cycling, there may be a problem with the drive. Replace the drive.
 Over speed limit (Overspeed)	Motor cable failure	Check for wiring failure and short-circuits.	Replace the motor cable.
	Encoder cable failure	Check for wiring failure and short-circuits.	Replace the encoder cable.
	Parameter setting failure	Motor ID [0x2000], encoder type [0x2001], encoder type [0x2002], and third party parameter [0x2800~] settings should be the same as the motor information.	Modify the parameters so they match the motor information.
		Check the [0x6091] setting.	Set the electronic gear ratio low.
		Check the settings for [0x2100] - [0x211F].	Readjust the gain according to the operation condition.
	Encoder failure		If an alarm occurs continuously after power cycling, there may be a failure in the motor. Replace the motor.
Drive failure		If an alarm occurs continuously after power cycling, there may be a problem with the drive. Replace the drive.	
 POS following (Excessive Position Error)	Parameter setting failure	Check the settings for [0x3000], [0x3003], and [0x3004].	Readjust the parameter according to the operation condition.
		Check the [0x6091] setting.	Set the electronic gear ratio low.
		Check the settings for position error range [0x6065] and position error	Readjust the parameter according to the operation



Alarm code name	Cause	Check list	Troubleshooting
		overtime [0x6066].	condition.
	Apparatus status failure	Check whether there is any restraint on the driving part.	Inspect the apparatus.
	Drive failure		If an alarm occurs continuously after power cycling, there may be a problem with the drive. Replace the drive.
<b>AL-52</b> Emergency stop (Emergency Stop)	Reserved		
<b>AL-53</b> Excessive SPD deviation (Excessive Speed Error)	Motor cable failure	Check for disconnection, wiring failure, and short-circuits.	Replace the motor cable.
	Encoder cable failure	Check for disconnection, wiring failure, and short-circuits.	Replace the encoder cable.
	Parameter setting failure	Motor ID [0x2000], encoder type [0x2001], encoder type [0x2002], and third party parameter [0x2800~] settings should be the same as the motor information.	Modify the parameters so they match the motor information.
		Check the [0x6091] setting.	Set the electronic gear ratio low.
	Apparatus status failure	Check whether there is any restraint on the driving part. Check the operation status of the limit contact sensor.	Inspect the apparatus.
	Encoder failure		If an alarm occurs continuously after power cycling, there may be a failure in the motor. Replace the motor.
Drive failure		If an alarm occurs continuously after power cycling, there may be a problem with the drive. Replace the drive.	
<b>AL-54</b> Encoder2 POS difference (Excessive Position)	Motor cable failure	Check for disconnection, wiring failure, and short-circuits.	Replace the motor cable.
	Encoder cable failure	Check for disconnection, wiring failure, and short-circuits.	Replace the encoder cable.



Alarm code name	Cause	Check list	Troubleshooting
Error of External Encoder)	Parameter setting failure	Motor ID [0x2000], encoder type [0x2001], encoder type [0x2002], and third party parameter [0x2800~] settings should be the same as the motor information.	Modify the parameters so they match the motor information.
		Set the load encoder scale (numerator/denominator)[0x2025, 0x2026], load encoder type [0x2021], load encoder direction [0x2022], load encoder position error level [0x2027], and load encoder position error initialization [0x2028] settings so they match the load encoder information and device characteristics.	Modify the parameter so it matches the load encoder information and device characteristics.
	Apparatus status failure	Check whether there is any restraint on the driving part.	Inspect the apparatus.
	Encoder failure		If an alarm occurs continuously after power cycling, there may be a failure in the encoder. Replace the encoder.
	Drive failure		If an alarm occurs continuously after power cycling, there may be a problem with the drive. Replace the drive.
 USB communication (USB Communication Error)	Reserved		
 reserved	Reserved		
 reserved	Reserved		
 Parameter checksum (Parameter Error)	When changing O/S	Check the parameter whose setting is set to the maximum value of the variable type.	Restore the initial parameter (0x1011). If you carry out the restoration, the parameter value changes to the initial value. Set the parameter before operation.
	Drive failure		If an alarm occurs continuously after power cycling, there may be a problem with the drive. Replace the drive.



Alarm code name	Cause	Check list	Troubleshooting	
<b>AL-64</b> Parameter range (Parameter Range Error)	Reserved			
<b>AL-70</b> Drive motor combination (Abnormal Combination of Drive and Motor)	Reserved			
<b>AL-71</b> Factory setting (Invalid Factory Settings)	Drive failure	Contact our service center.	If an alarm occurs continuously after power cycling, there may be a problem with the drive. Replace the drive.	
<b>AL-72</b> GPIO setting (Abnormal Input/Output Contact Setting)	Reserved			
<b>AL-80</b> Enc2 communication (Load Encoder Communication Error)	Load encoder cable failure	Check for disconnection, wiring failure, and short-circuits.	Replace the encoder cable.	
	Parameter setting failure	The load encoder type [0x2021] and load encoder setting [0x202B] parameter settings should be the same as the encoder information.	Modify the parameters so they match the motor information.	
	<b>AL-81</b> Enc2 cable open (Load Encoder Cable Disconnection)	Load encoder failure		If an alarm occurs continuously after power cycling, there may be a problem with the motor. Replace the motor.
<b>AL-83</b> Enc2 Z phase open (Load Encoder Z-phase Disconnection)	Drive failure		If an alarm occurs continuously after power cycling, there may be a problem with the drive. Replace the drive.	

## 12.3 Servo Warning

If the drive detects an error that is classified as a servo warning, it will trigger a warning. In this case, the drive will maintain normal operating conditions. After the cause of the warning is eliminated, the warning will be cleared automatically. You can specify if each warning is checked with a warning mask configuration (0x2014). Masking servo warnings does not remove risks associated with the warnings. There is a risk that the drive may burn out. Keep this in mind when configuring the mask settings.

Bit	Warning code	Warning name
1	W02	Low voltage of encoder battery
2	W04	Software position limit
4	W10	Operation overload
5	W20	Abnormal combination of drive and motor
6	W40	Low voltage
7	W80	Emergency signal input
14	AL-34	Alarm mask for encoder Z-phase loss

Warning state (Code)	Cause	Check list	
 LOW_BATT (Low Voltage of Encoder Battery)	Parameter setting failure	Check the [0x2005] setting.	If you want to use an absolute encoder as an incremental encoder, set it to 1 so the alarm does not occur.
	Battery connection failure or no connection	Check the battery connection status.	Properly connect the battery.
	The battery voltage is low	Check whether the battery voltage is 3.3 V or higher.	Replace the battery.
 SW_POS_LMT (Software Position)		When the software position limit function is used, a position command that is larger than the limit has been input.	

Limit)			
 OV_LOAD (Operation Overload)	The drive operates continuously, exceeding the rated load.	Continuous operation in the constant speed area or in the stopped state Check whether the load is below 100% in the load rate [0x2603].	Change the capacity of the drive and motor. Adjust the gain.
	Motor brake failure	Check whether the motor brake is open at SVON.	Supply power to the motor brake.
	Parameter setting failure	Motor ID [0x2000], encoder type [0x2001], and encoder type [0x2002] settings should be the same as the motor label information.	Modify the parameters so they match the motor label information.
		Check the overload detection default load rate setting [0x200F].	Set it to an appropriate value.
	Apparatus status failure	Operation should be normal.	Inspect the apparatus.
	Motor cable failure	Check for wiring failure and short-circuits.	Replace the motor cable.
	Encoder cable failure	Check for wiring failure and short-circuits.	Replace the encoder cable.
 SETUP (Setting Failure)	Abnormal combination of drive and motor	Check whether the current capacity of the motor is larger than the drive's current capacity.	Lower the torque limit value or replace the motor to one that has a lower current capacity than the drive.
	IO setting failure	Check whether the signal allocation has overlapped in the digital input signal setting [0x2200] - digital output signal 8 setting [0x2217].	Set the parameters properly according to the operation status.
	Main power	Check whether the main power voltage is DC 24 V or higher.	Inspect the power again.

UD_VTG (Low Voltage)	input voltage failure	Check whether the [0x2605] value is 24 - 80 V while the main power is being applied normally.	Replace the drive.
	Power voltage drops during operation	Check the wiring status of the main power.	Use the 3-phase supply voltage.
 EMG (Emergency Signal Input)	EMG contact failure	Emergency stop occurred by an EMG contact. Check the settings of the wiring and drive parameters (drive control input 1 [0x211F], digital input signal 1 setting [0x2200] - digital input signal 16 setting [0x220F]).	Set the wiring and parameters properly according to the operation status.
	Drive failure		If an alarm occurs continuously after power cycling, there may be a problem with the drive. Replace the drive.

## 12.4 Servo Drive Overload Curve

### ■ Servo Drive Overload Graphs

Capacity	3A		6A	
	16[kHz]	48[kHz]	16[kHz]	48[kHz]
Load factor (%)	Operation & Stall	Operation & Stall	Operation & Stall	Operation & Stall
100%	∞	∞	∞	∞
110%	31536000	31536000	31536000	31536000
120%	31536000	56192	1808384	1924
130%	31457280	28096	904192	962
140%	15728640	14048	452096	480
150%	7864320	7024	226048	400
160%	3932160	3512	113024	214
170%	1966080	1756	56512	114
180%	983040	878	28256	90
190%	491520	439	14128	79

200%	245760	237	7064	66
210%	122880	130	3532	56
220%	61440	93	1766	40
230%	30720	73	883	27
240%	15360	66	66	20
250%	7680	60	60	19
260%	3840	50	50	17
270%	1920	43	43	17
280%	960	37	37	16
290%	595	35	35	15
300%	313	32	32	12

■ PHOX03-080NS-XX00 (16 kHz) Overload Graphs

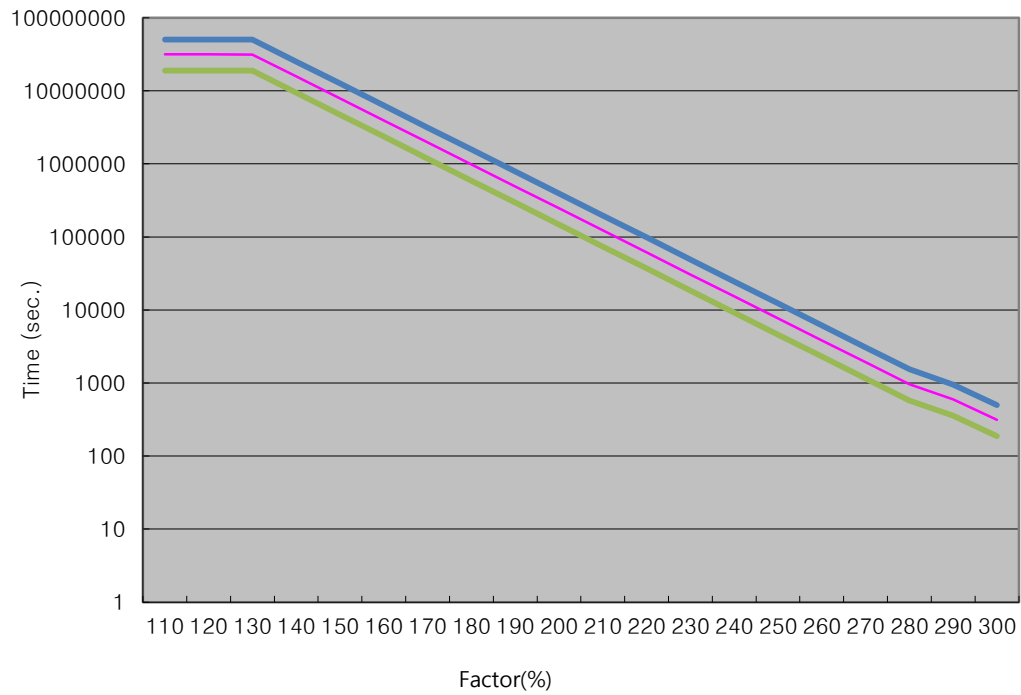

■ PHOX03-080NS-XX00 (48 kHz) Overload Graphs

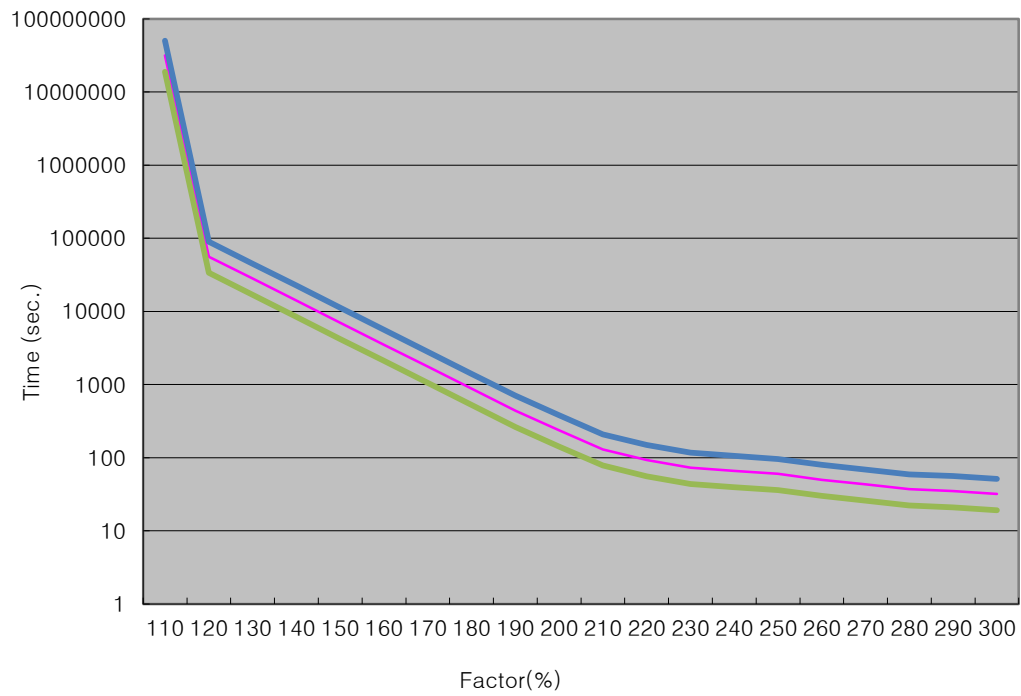

■ PHOX06-080NS-XX00 (16 kHz) Overload Graphs



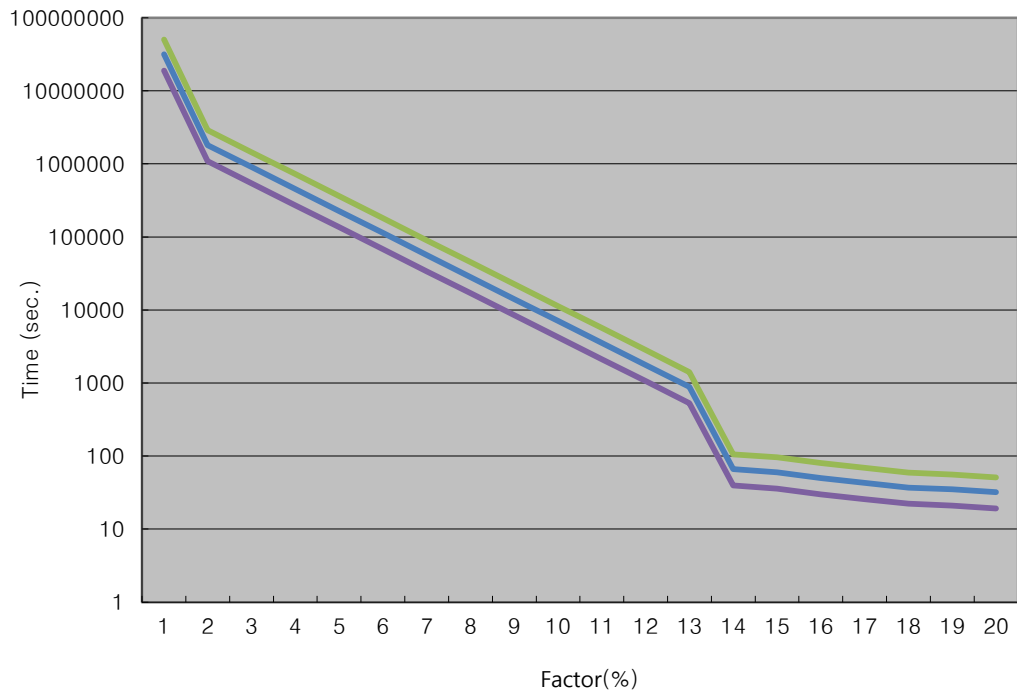



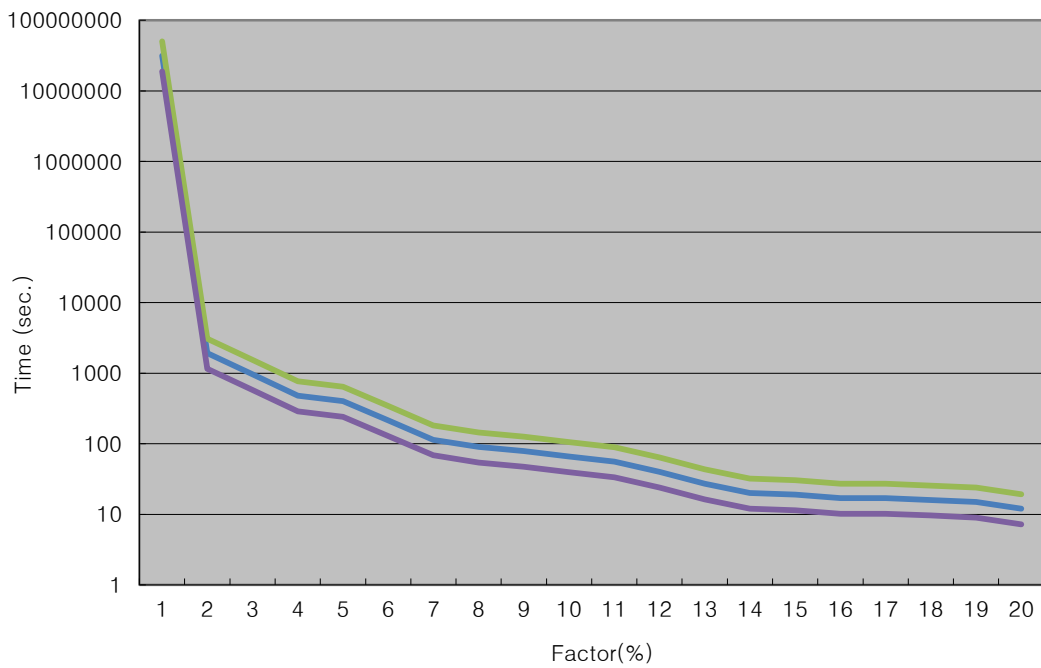

■ PHOX06-080NS-XX00 (48 kHz) Overload Graphs





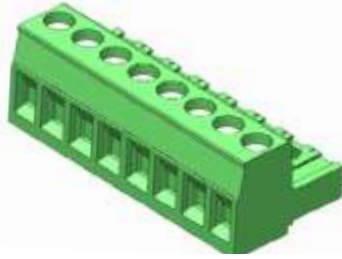
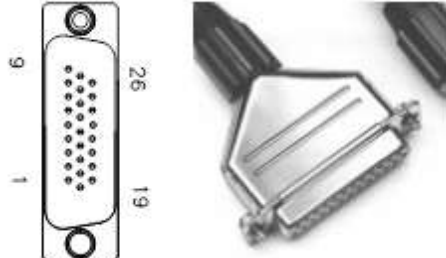

## 12.3 Options and Peripheral Devices

### ■ Option Specifications

Type	Product Name	Name (Note 1)	Applicable Drive	Specifications
For power	POWER Connector	MSTB 2,5/ 8-ST-5,08	PHOENIX SERIES	 <p>- Connector : MSTB 2.5/8-ST-5.08</p>
For I/O	I/O Connector	10090769-P264ALF	PHOENIX SERIES	 <p>- Connector : 10090769-P264ALF - Housing : 3357-9215</p>
For brake	Brake Connector	IPD1-02-D-K	PHOENIX SERIES	 <p>- <b>PLUG:</b> IPD1-02-D-K</p>
For STO	STO Connector	IPD1-03-D-K	PHOENIX SERIES	 <p>- <b>PLUG:</b> IPD1-03-D-K</p>
For brake and STO Terminal	Terminal	CC79L-2024-01	PHOENIX SERIES	

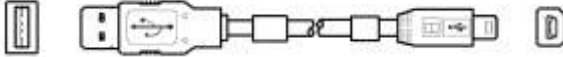
Type	Product Name	Model name	Applicable Drive	Specifications
For signaling	ENCODER (A) Connector	10090769-P154ALF	PHOENIX SERIES	 <p>- Connector : 10090769-P154ALF - Housing: 3357-9209</p>
For signaling	ENCODER (B) Connector	10090770-S154ALF	PHOENIX SERIES	 <p>- Connector 10090770-S154ALF - Housing: 3357-9209</p>
For signaling	Communication cable	APCS-CN5L7U	PHOENIX SERIES & L7 SERIES	<p>[PC - USB Port]                      [Servo Drive - Mini USB]</p>  <p>1. PC connection: USB A Plug  a. Drive connection (USB): Mini USB 5P plug  b. Electrical requirements:  Double shielded, twisted pair, EMI filter installation  (similar product: KU-AMB518 by SANWA)</p>

## 13. Test Drive

For a safe and proper test drive, make sure to check the following prior to the test drive. If there is a problem, take appropriate measures before the test drive.

### ■ Servo Motor State

Is the motor correctly installed and wired?

Is each connecting part secured tightly?

For a motor with oil seals fittings, is there any damage to the oil seal?

Has oil been properly applied?

If you test drive a servo motor that has been stored for an extended period, make sure to check the motor according to the maintenance and inspection methods for the servo motor. For more information on maintenance and inspection, refer to Chapter 12. Maintenance and Inspection.

### ■ Servo Drive State

Is the drive correctly installed, wired, and connected?

Is the supply voltage for the servo drive correct?

## 13.1 Preparation for Operation

Perform the test drive in the following order:

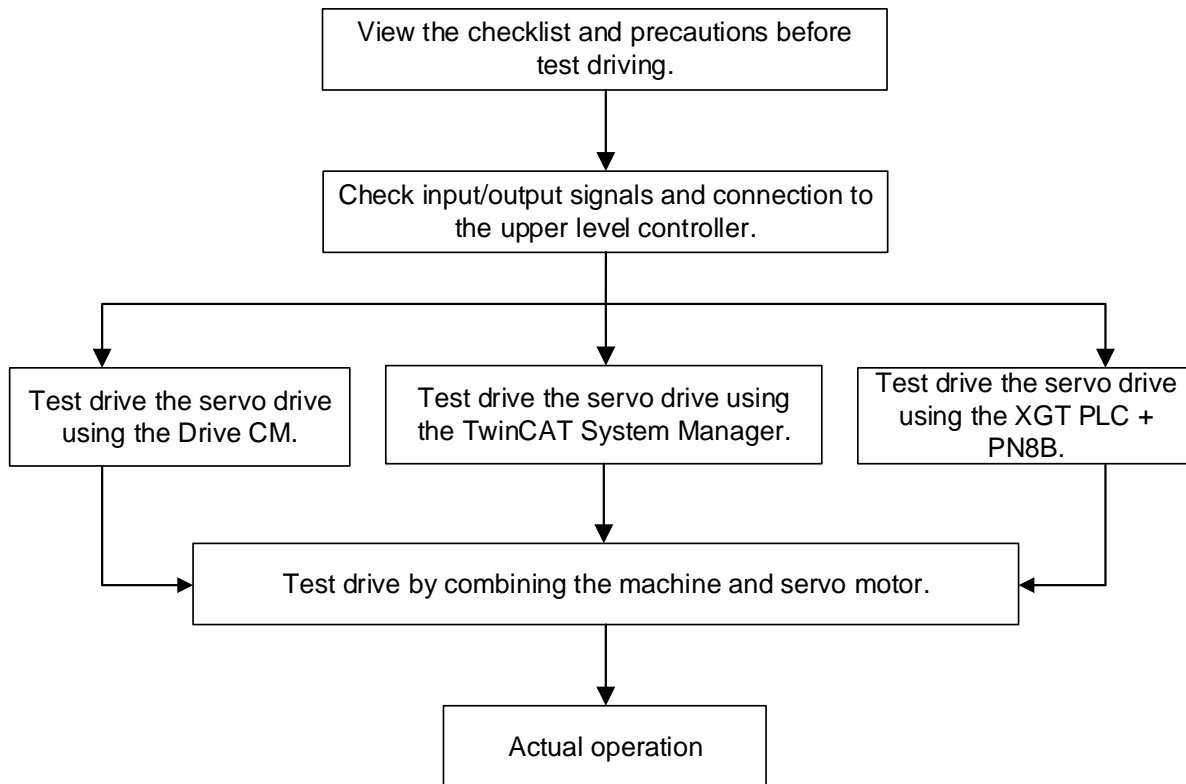

Before the test drive, check that the upper level controller and the servo drive are correctly wired, and the objects of the servo drive are correctly configured.

## 13.2 Test Drive using Drive CM

### ■ Test Drive Procedure

Order	Handling	Notes
1	Run the drive CM.	

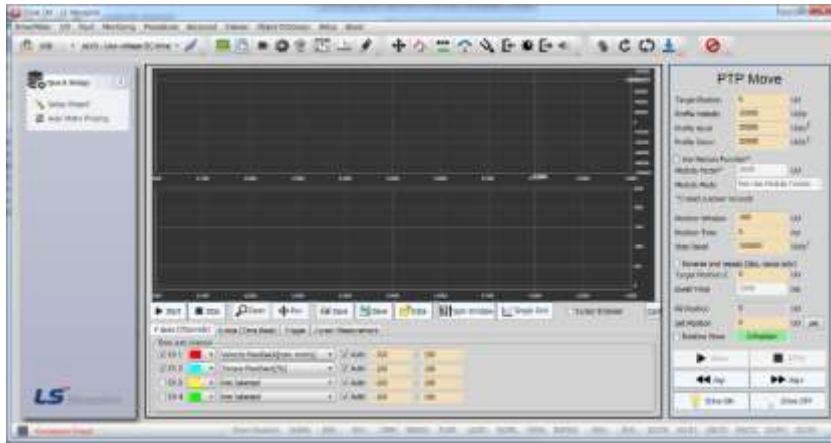

Select the connection method and drive type and click the Connect button.

2

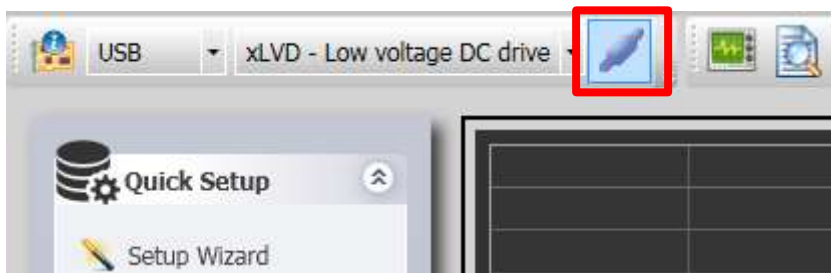
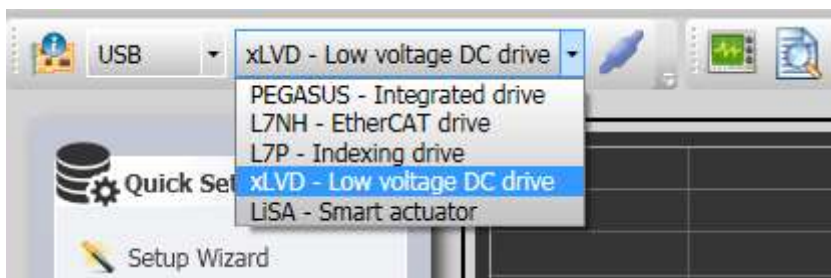

If the drive and PC are connected normally, a "Connected" message and green light are displayed at the bottom-left corner of the program as shown below.



3

To set the motor and encoder, click Motor Encoder in the Drive/Motor menu.

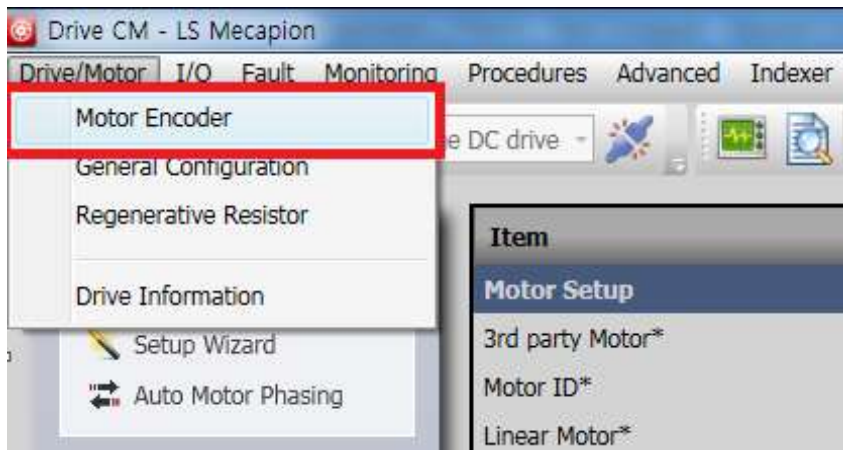

4 Enter a parameter in Motor Setup.  
If you are not using our motor, select the 3<sup>rd</sup> Party Motor check box.

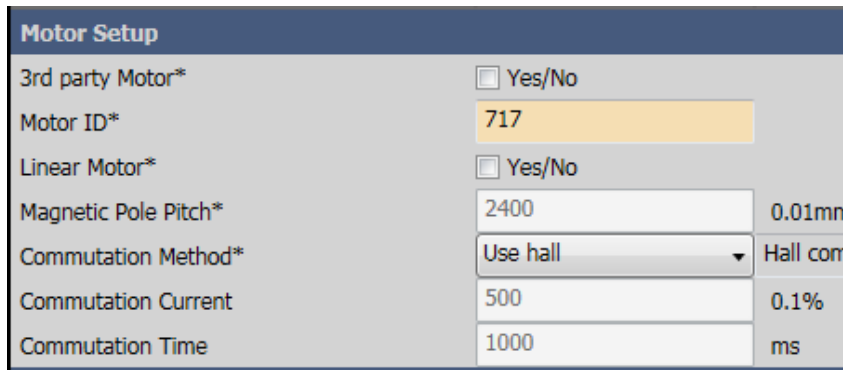

5 Enter a parameter in Encoder Setup.  
To quickly set the encoder, click the Quick Setup button.

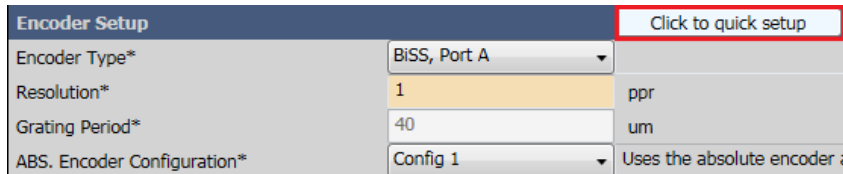

6 Select a motor type and click Next.



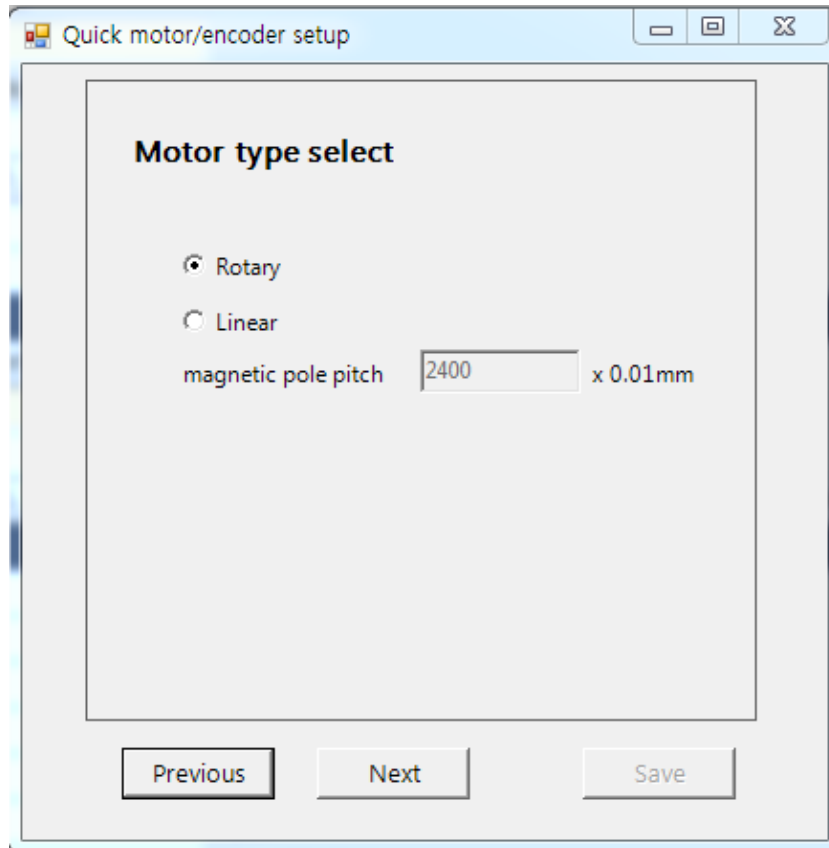

Set the encoder type, connecting port, resolution, number of bits, communication method, and bit position, and click Next.

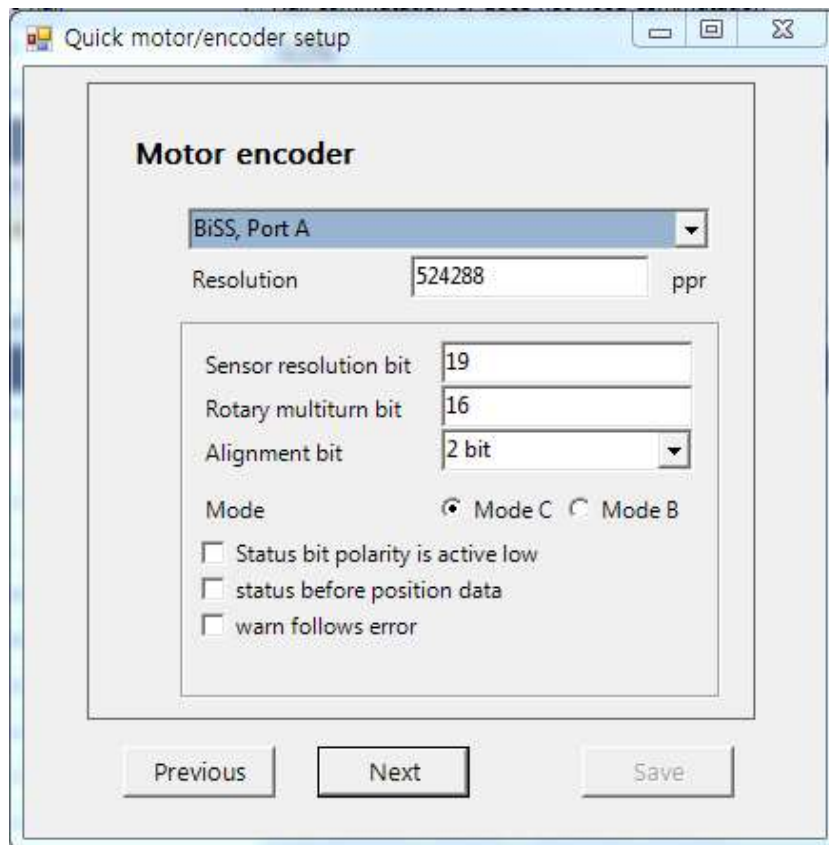

Set the load-side encoder. If it is not a full-closed operation, select Not Selected and click Next.

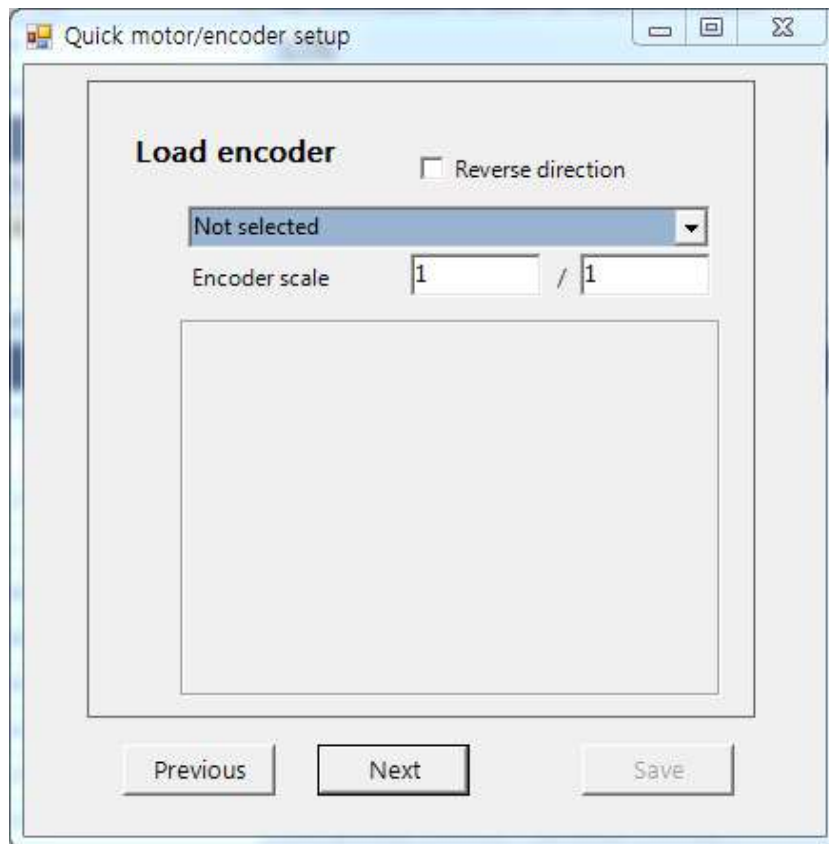

Set the parameters regarding the motor overheat prevention using the motor thermal time constant and I2T algorithm and click Save. Then, close the window.

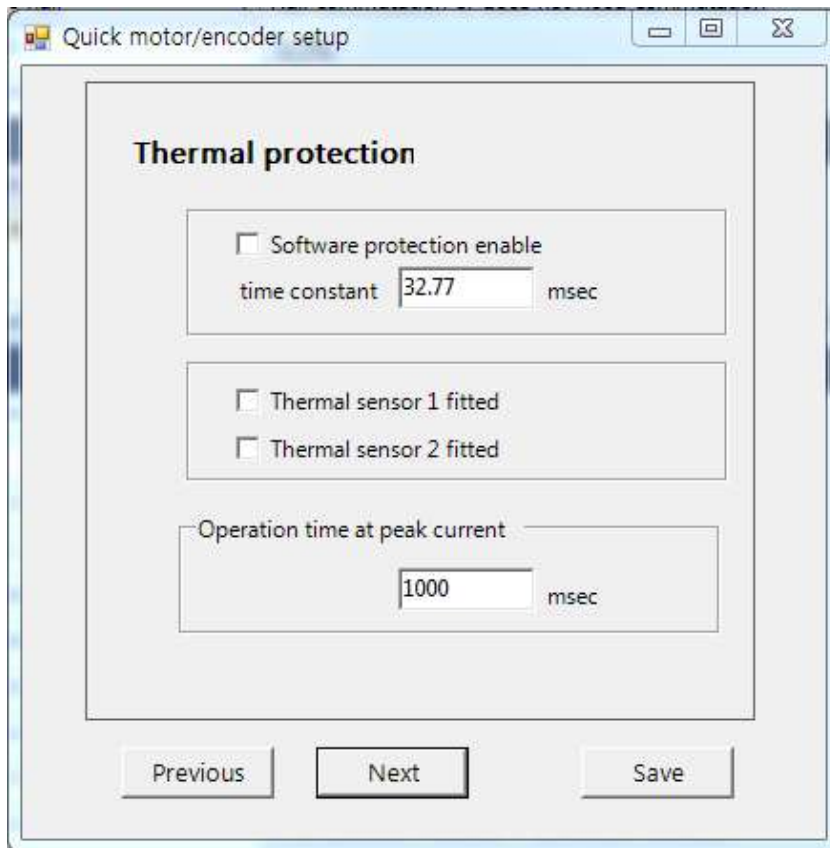

If you are not using our motor, set the 3<sup>rd</sup> Party Motor Setup. (If you do not check the 3<sup>rd</sup> Party Motor check box in Motor Setup, it is not activated.)

7

3rd Party Motor Setup		
Type*	Rotary	
Number of poles*	8	
Rated Current*	5.37	Arms
Maximum Current*	16.1	Arms
Rated Speed*	3000	rpm
Maximum Speed*	5000	rpm
Inertia or Mass*	1.927	Kg•m <sup>2</sup>
Torque or Force constant*	0.616812	Nm/A
Phase Resistance(Y wound)*	0.373	ohm, Rph
Phase Inductance(Y wound)*	2.519	mH, Lph
TN curve data 1*	3000	rpm
TN curve data 2*	60	%
Hall Offset*	0	deg
Motor thermal time constant*	32.77	ms

8

Select the operation method you want to use from the Procedures tab and perform the test drive.

(\*Secure enough operation area for the motor before the test drive.)

9	<p>If you perform the test drive using the Procedure function, refer to Chapter 8. Procedure Function.</p>	

### 13.3 Test Drive Using TwinCAT System Manager

■ Test Drive Procedure

Order	Handling	Notes
1	<p>Before launching the TwinCAT System Manager, copy the servo drive XML file into the schema folder (C:\TwinCAT\Io\EtherCAT).</p>	
2	<p>Launch the TwinCAT System Manager.</p>	
3	<p>Select the target system. When performing the test drive using a remote system, select the device.</p>	
4	<p>Restart the TwinCAT System with Config Mode. Using the Set/Reset TwinCAT to Config Mode icon under the TwinCat System Manager, you can restart the system with Config Mode.</p>	

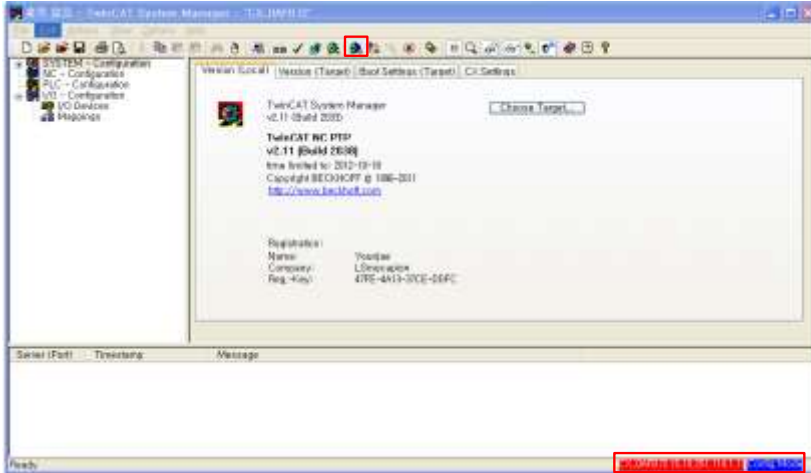

Search for EtherCAT communication-based devices connected to the system.

Right-click I/O Devices in the Work Space pane of the TwinCAT system, and then click Scan Devices.

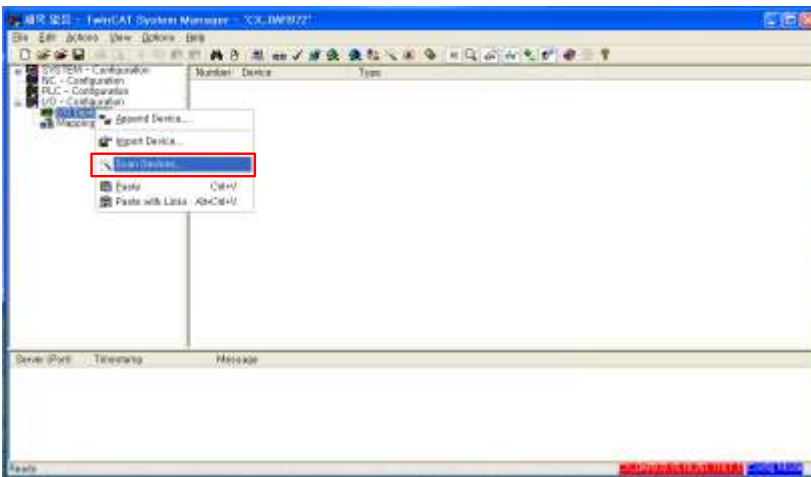

5

If the dialog window below appears in the TwinCAT System Manager, click OK.

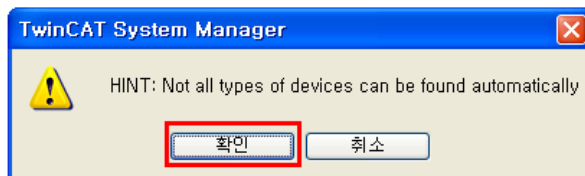

If the New I/O devices found dialog window appears, select the device or servo drive that needs to be test driven and click OK.

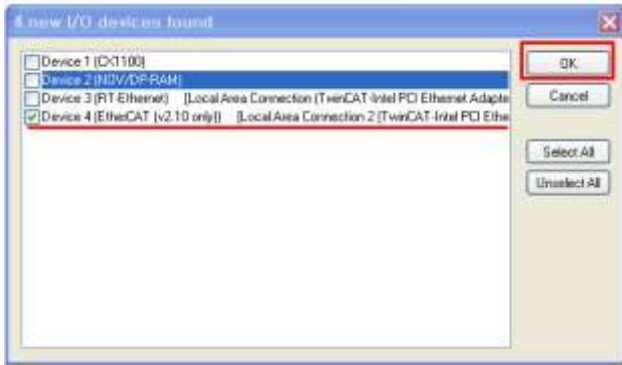

If the dialog window below appears, click Yes.

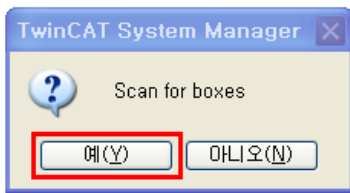

6

Add the servo drive's NC Task to the NC-Configuration.  
If the dialog window below appears, click Yes.

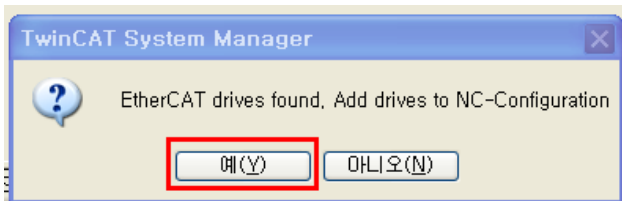

7

Switch the TwinCAT System Manager to a free run state to allow it to control devices independently of the TwinCAT PLC and so on.  
If the dialog window below appears, click Yes.

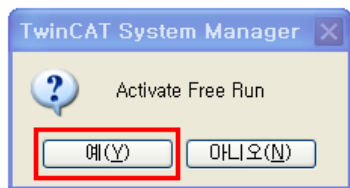

8

Make sure NC Task is added to the NC-Configuration tree in the workspace on the left, and the servo drive is registered to the I/O-Configuration tree.  
If the connected servo drive is registered, select it.  
Click the Online tab on the right side to verify that Current State and Requested State are in the SAFEOP state.

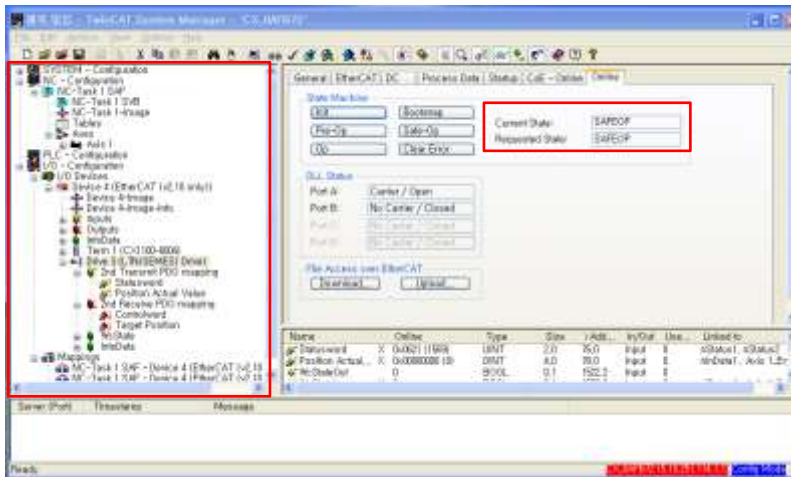

Switch the EtherCAT communication state from SafeOP to OP, enabling MailBox Communication and Process Data Communication. Click the Generate Mappings icon on the menu bar. Map the images defined in NC Task and I/O Device.



9

Click the Check Configuration icon on the menu bar. Check if the currently set configuration is valid.



Click the Activate Configuration icon on the menu bar. Save Project Configuration in Windows Registry.



10

Verify if the EtherCAT communication state has switched from SafeOP to OP. Check the communication LED. The Link/Activity LED is flickering. The RUN LED is on. Check the online state of the I/O device of the TwinCAT system. In the I/O-Configuration tree of the workspace, click the servo drive, and then click the Online tab to check if Current State and Requested State are in the OP state.

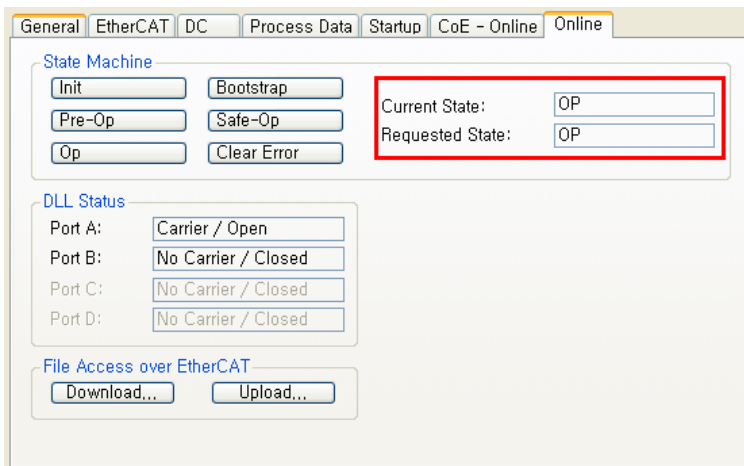

Verify if the state displayed at the bottom-right of the TwinCAT System Manager menu window is in the Run state.



11

We have finished adding NC-Task and I/O Devices (servo drive) to the TwinCAT System Manager.

■ **Setting NC-Task Axis Parameters**

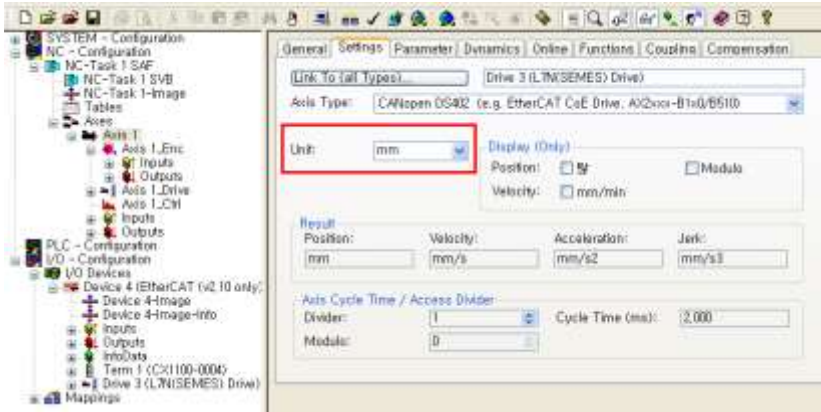
Order	Handling	Notes
1	<p>Set the display units for the relevant axis.                      Select Axis1.                      Click the Settings tab.                      Click the display units for position and speed.</p>  <p>Note: Remember the actual units will not be converted even if the units shown in the figure above was converted to mm or degrees.                      Note: Change the units and tune the Axis Scaling Factor below.</p>	



2

Set the Axis Scaling Factor. The Axis Scaling Factor determines the distance of the axial load movement while the motor shaft makes one revolution.

Select Axis1.

Click the Parameter tab.

Set the Scaling Factor.

Then, download the settings.

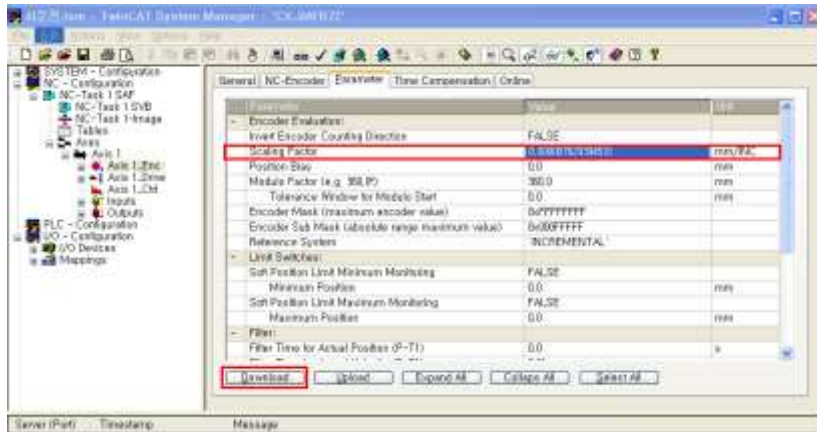

Note: The default is 0.0001 if the scaling factor is not set.

Note: After configuring the settings, download them.

3

Set the speed parameter of the test drive axis.

Select Axis 1.

Click the Parameter tab.

Set Maximum Velocity, Manual Velocity (Fast), and Manual Velocity (Slow). Then, download the settings.

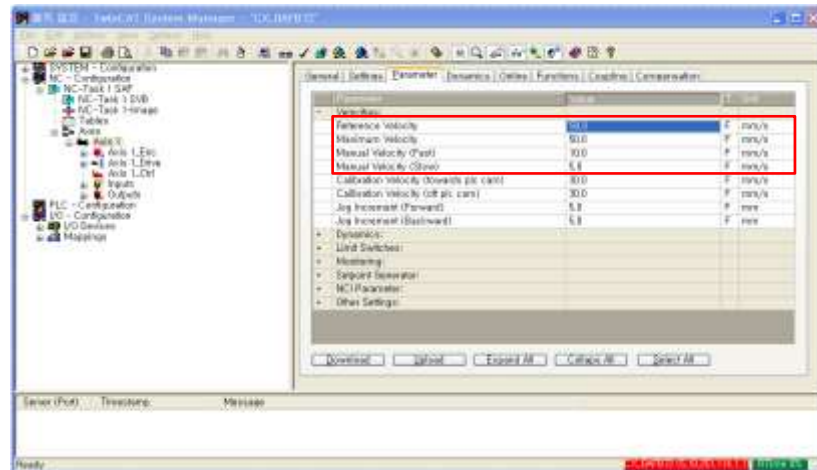

4

Set the speed, acceleration, and jerk of the test drive axis.

Set the acceleration, deceleration, and jerk directly for the test drive axis; the TwinCAT NC can calculate the acceleration based on the configured profile timing.

Select Axis 1.

Click the Dynamics tab.

Set the acceleration, deceleration, and jerk directly.

Select the Direct button.

Set the acceleration, deceleration, and jerk.

Download the settings.

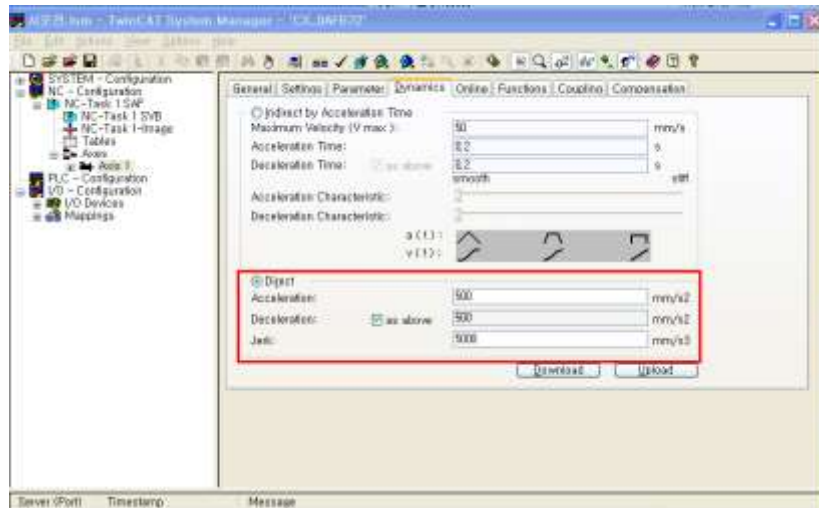

Set the acceleration, deceleration, and jerk indirectly.

Set the acceleration, deceleration, and jerk indirectly by setting the acceleration time. If you change the acceleration time, the acceleration value will automatically be changed.

Select the Indirect by Acceleration Time button.

Set the acceleration, deceleration, and jerk.

Download the settings.

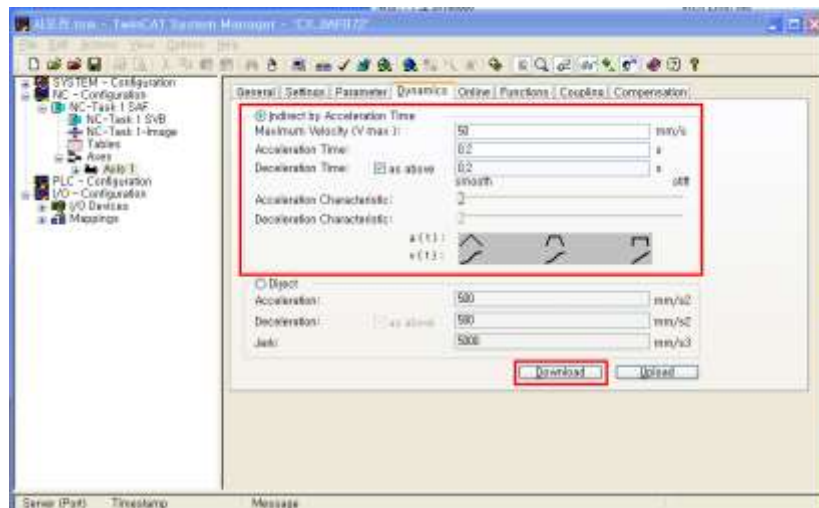

5

Set the Position Lag Monitoring (Following Error).

Select Axis 1.

Click the Parameter tab.

Set the Position Lag Monitoring.

Set the Position Lag Filter Time.  
Download the settings.

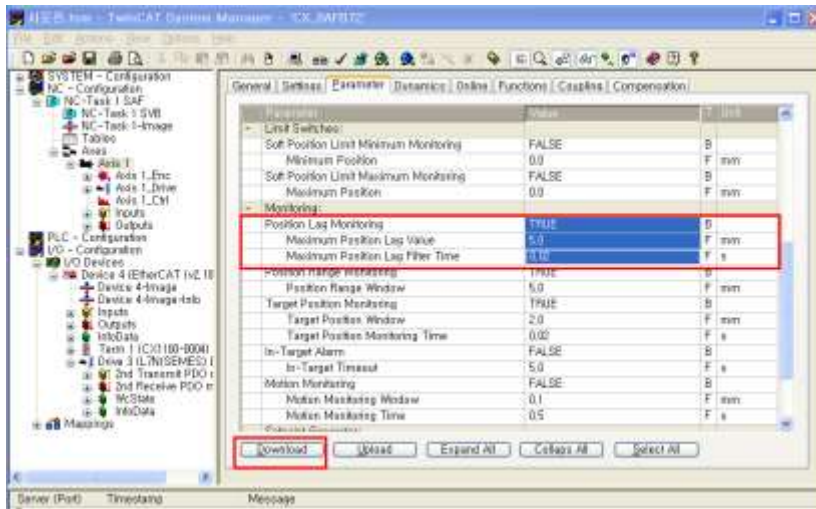

Note: The Position Lag Monitoring is the difference between the position reference and the actual position at a given cycle time. When Position Lag Monitoring is enabled, the TwinCAT NC generates an alarm if the position error exceeds the settings.

■ Test Drive the Servo Drive Using TwinCAT NC Axis

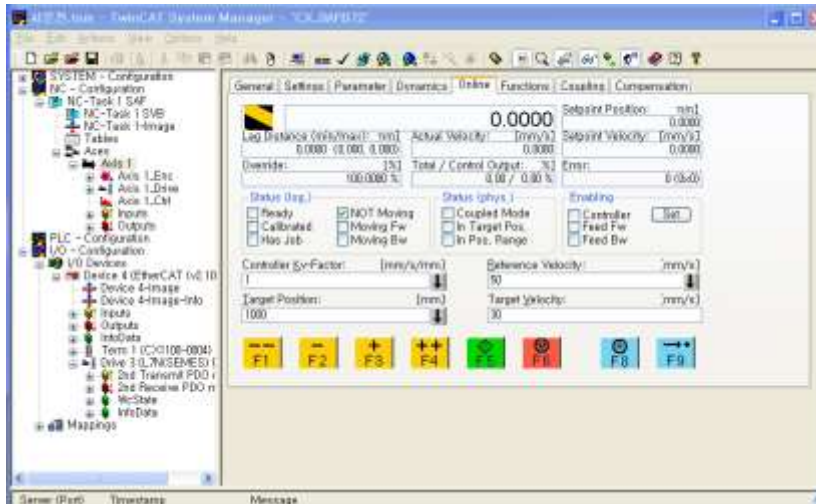
Order	Handling	Note
1	<p>Make sure TwinCAT NC axis is "Servo On." Select Axis 1. Click the Online tab.</p>  <p>Click the Set button.</p>	

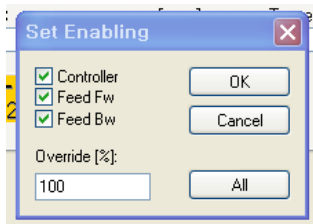

Click to select Controller, Feed Fw, and Feed Bw in Enabling.  
Set the Override to 100%.  
Click OK.

Use the buttons shown below to manually perform the test drive (JOG).

2

	Perform a reverse rotation at the specified Manual Velocity (Fast).
	Perform a reverse rotation at the specified Manual Velocity (Slow).
	Perform a forward rotation at the specified Manual Velocity (Slow).
	Perform a forward rotation at the specified Manual Velocity (Fast).

Perform the test drive with relative coordinates.  
Set the Target Position.  
Set the Target Velocity.  
Click the F5 button.

3

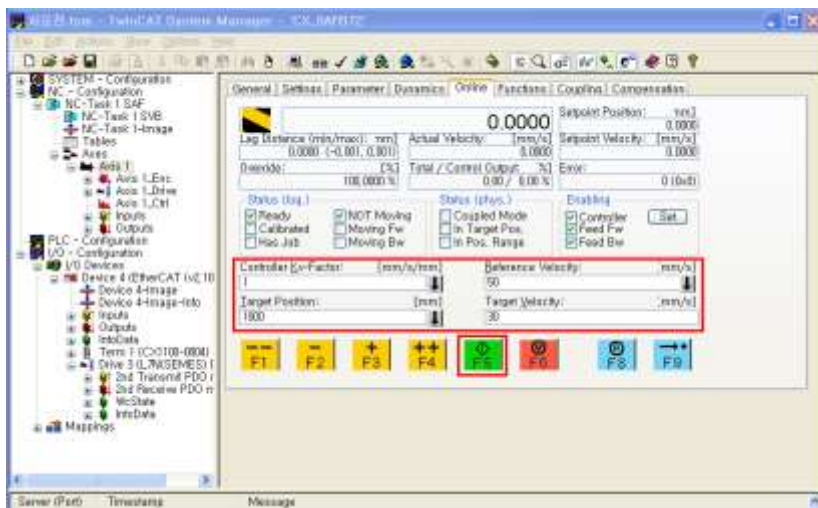

Move it to the Target Position from the current position, decelerating to a stop.  
After moving it to the Target Position, verify if the Set Position is the same as the Target Position.

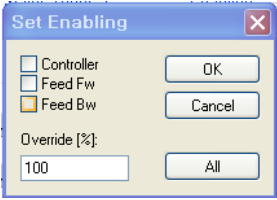
	<p>Click the F6 button to stop driving with relative coordinates.                  When the alarm goes off, click the F8 button to reset the alarm.                  Note: If the position limit is enabled, set the Target Position within the limit.</p>	
4	<p>Make sure the TwinCAT NC axis is "Servo Off."                  Click Set.                  Click to clear Controller, Feed Fw, and Feed Bw in Enabling.                  Click OK.</p> 	
5	<p>Test driving the drive using the TwinCAT NC axis is completed.</p>	

## 13.4 Test Drive Using LSI PLC (XGT + PN8B)

### ■ Test Drive Procedure

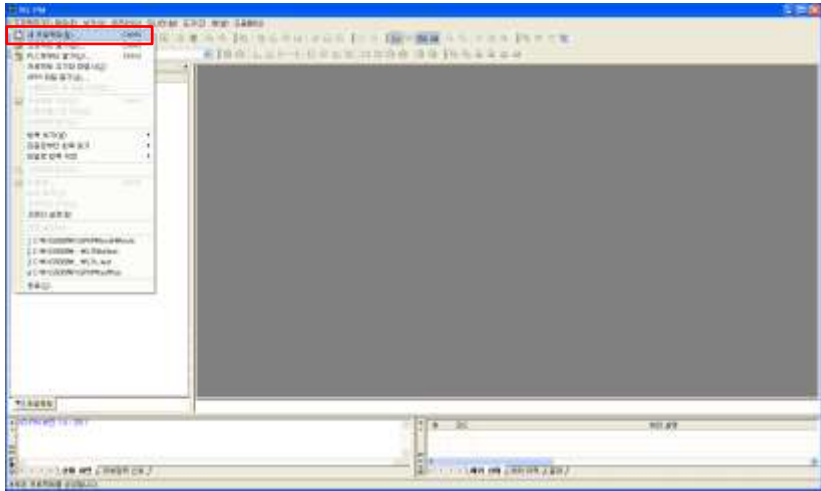
Order	Handling	Note
1	<p>Launch the XG-PM.</p>	
2	<p>Create a new project.                  On the menu bar, click Project → New Project.</p> 	
3	<p>Name the new project.</p>	

Select the PLC series and the CPU type.  
 Select the module type (XGF-PN8B), and click OK.

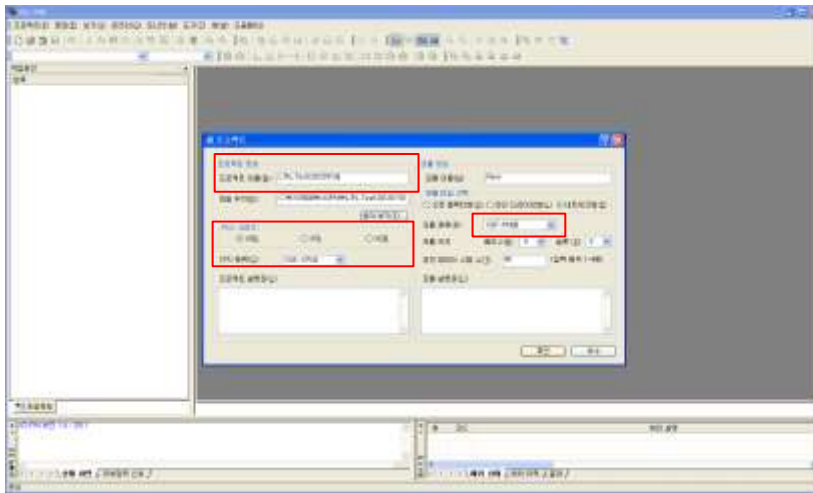

The PC and the PLC are connected for communication.  
 On the menu bar, click Online → Connection.

4

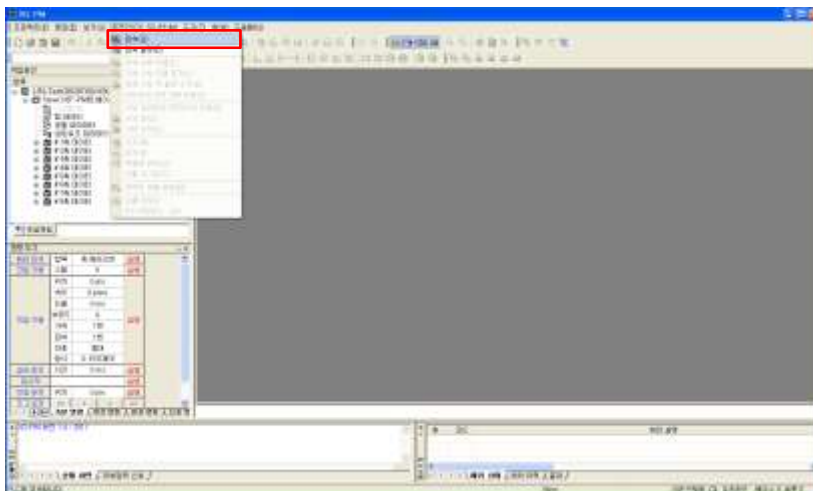

When the PC and the PLC are connected, the connection between the PLC and the servo drive will be enabled as shown in the figure below.

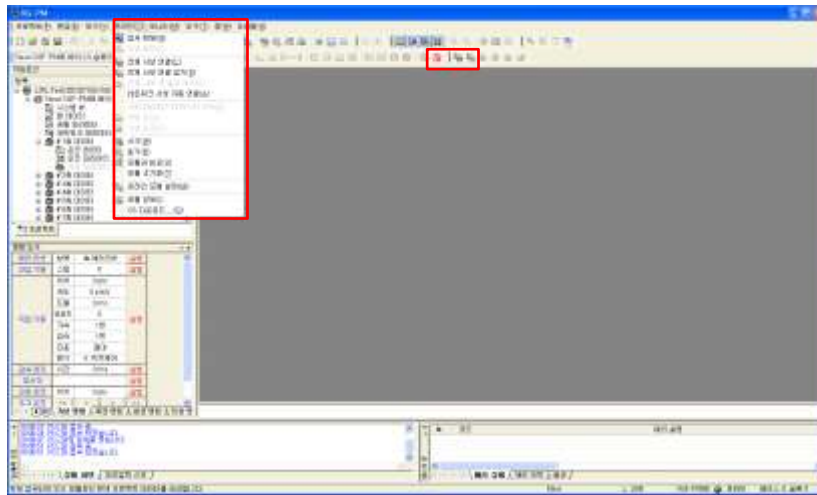

Connect the PLC with the servo drive.  
 For the first connection, enable the network parameters and servo parameters in the workspace on the left through Connect Network Servo Automatically.  
 After the servo drive and the PLC are connected, the servo parameters and the motor test drive function will be enabled.  
 Connecting multiple shafts enables as many servo parameters as the number of connected shafts.

5

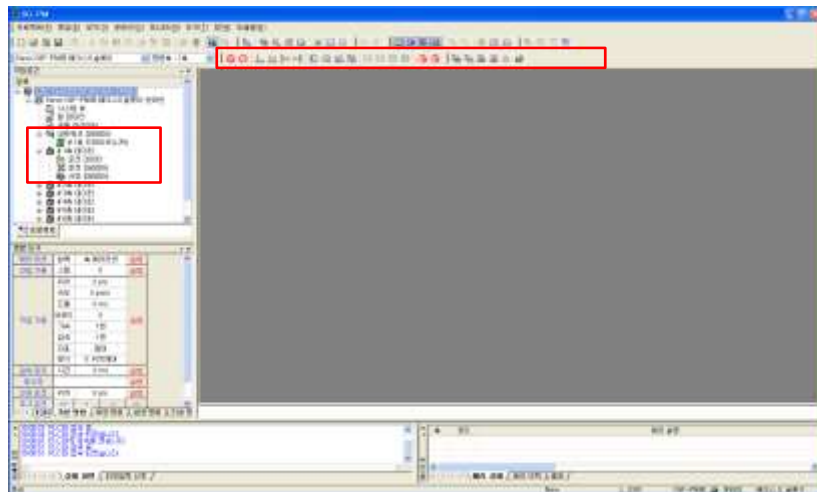

Check the state of the status LEDs.  
 The Link/Activity LED is flickering.  
 The RUN LED is on.  
 Note: Automatic connection of the network servo registers the device connected to the XGT, and initializes the parameters of the connected device.  
 Note: For subsequent connections, connect or disconnect the XGT and the servo drive by connecting the entire servo or disconnecting

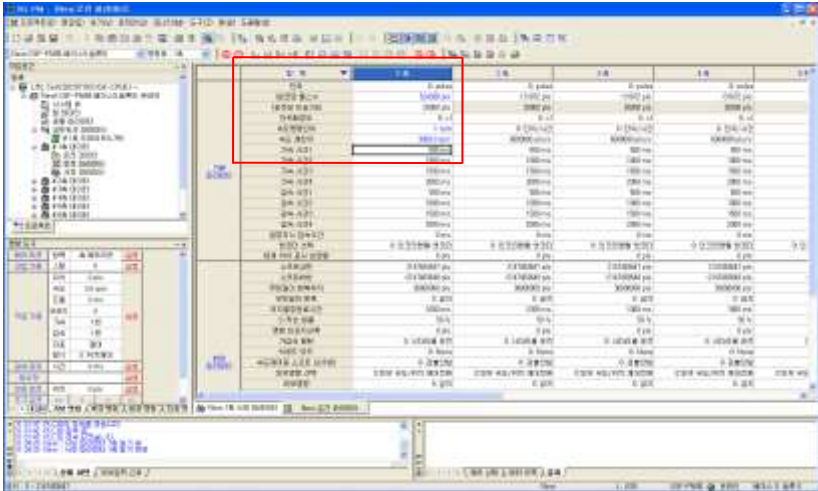

	<p>them respectively, since the device has been registered and its parameters initialized through automatic servo connection.</p> <p>Note: In case there is any change in the XGT-connected device, initialize the parameters of the device connected by the automatic servo connection.</p>	
<p>6</p>	<p>Set the Driving Parameters of the Test Drive Axis → Basic Parameters.</p> <p>Enter the number of encoder pulses per motor revolution.</p> <p>Encoder resolution of the 19-bit = 524288</p> <p>Check the motor specifications, and then configure the appropriate settings.</p> <p>Set the units for the speed command.</p> <p>It can be set as rpm or mm/s.</p> <p>Set the speed limit.</p> <p>Check the motor specifications, and then configure the appropriate settings.</p> 	
<p>8</p>	<p>Set the Driving Parameters of the Test Drive Axis → Manual Operation (Jog) Parameters.</p>	



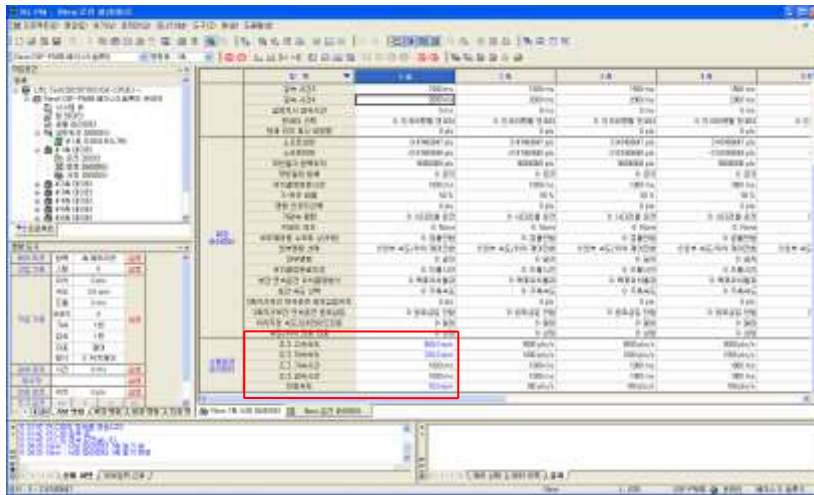

Set the servo parameters of the test drive axis.

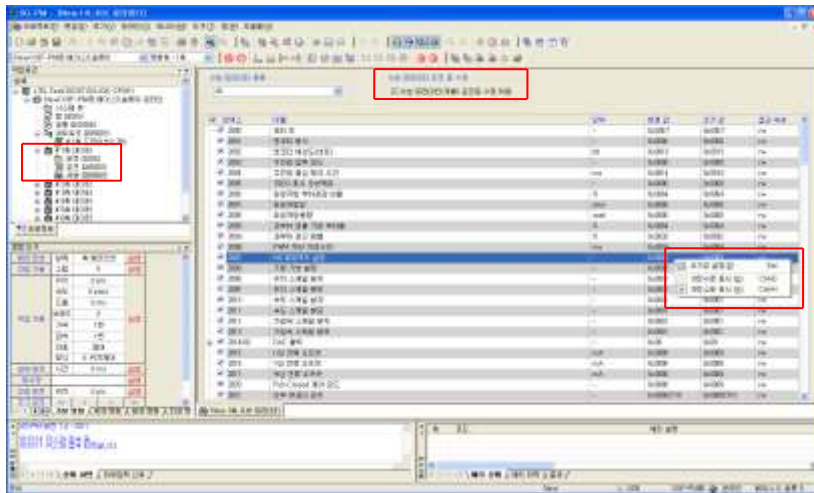

9

Select parameters that you want to change, and then change them. To change the parameters during operation, click to select the Allow to Modify Servo Parameters During Operation checkbox at the top of the pane.

You can display parameter values as decimals or hexadecimals.

11

Save the configured parameters.

On the menu bar, click → Online → Write.

With the Write Project dialog window enabled, click to select the Operation Data of Test Drive Axis, the Operation Parameters, and the Servo Parameters checkboxes, and then click OK to save the configured parameters.

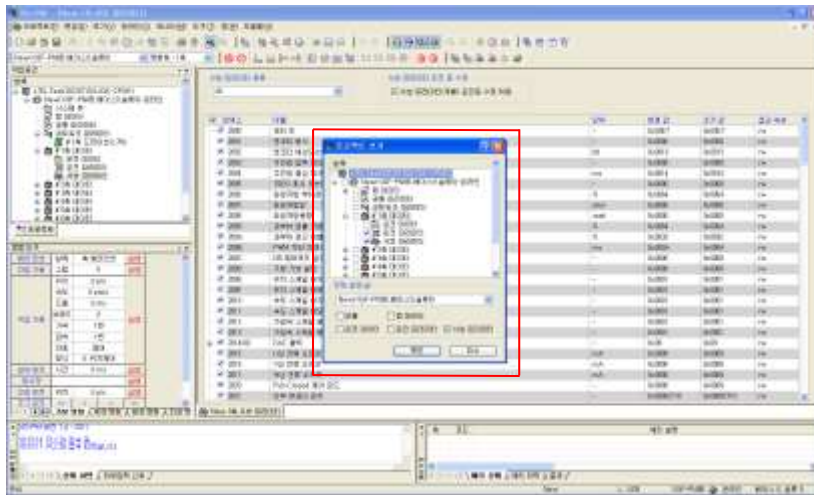

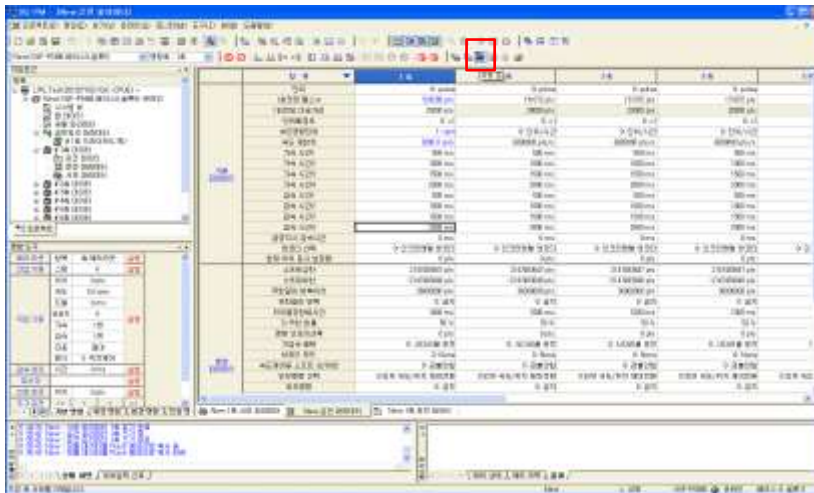

12

Turn on the servo.  
On the menu bar, click the Servo ON icon to turn on the servo of the servo drive of the test drive axis.

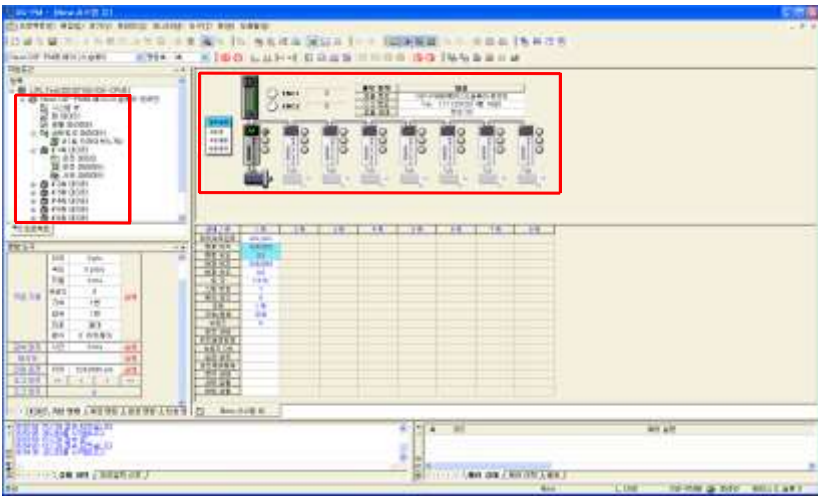

13

Save the configured parameters.  
Click the System View tab and the Basic Command tab in the workspace to check the state of the servo drive as shown in the figure below.

		
<p>14</p>		<p>Test drive using jog operation and inching operation</p> <p>For the jog operation, the motor is driven with the settings of the operation parameters.</p> <p>For the inching operation, the motor moves to the entered position. After entering the position value, click the Run button to perform the test drive.</p>
<p>15</p>	<p>Point to Point Test Drive</p> <p>Select Workspace → Command Tool → Point Command tab.</p> <p>Set the operation data.</p> <p>On the Point Command tab in the workspace, specify the number of point operations and the order.</p> <p>On the menu bar, click Online → Write to store the operation data.</p> <p>On the Point Command tab, click the Run button to perform the</p>	

test drive.

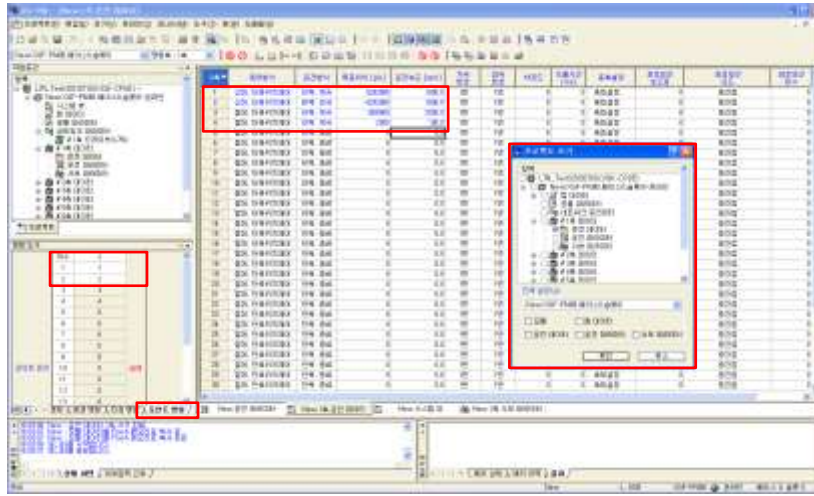

16 Test driving the drive using the XGT is completed.

## 13.5 Preparation for Indexing Operation

Perform the test drive in the following order:

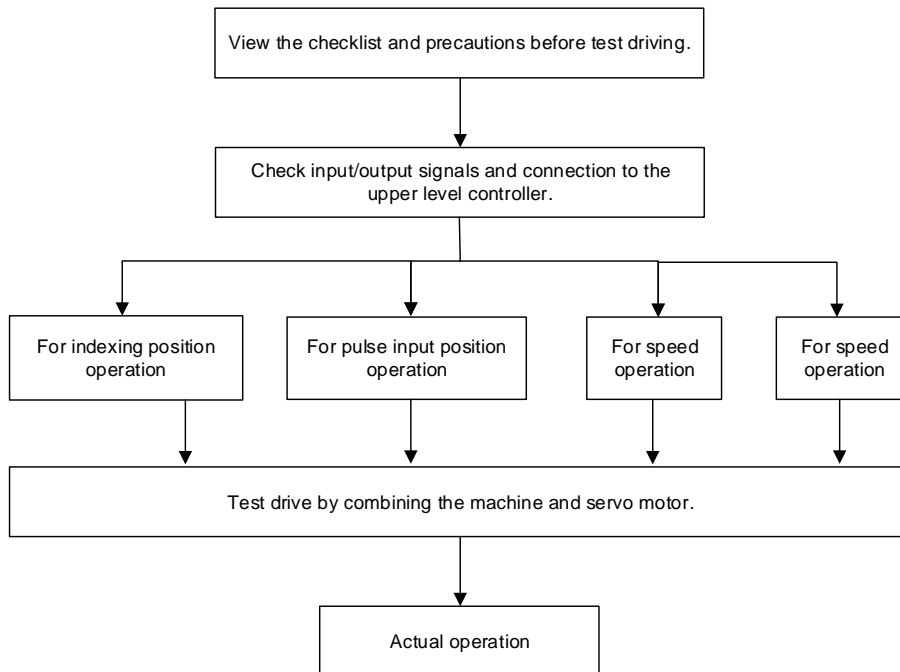

Before the test drive, check that the upper level controller and the servo drive are correctly wired, and the parameters of the servo drive are correctly configured.

## 13.5.1 Indexing Position Mode

Order	Handling	Notes
1	Check the power and input signal circuit again and turn on the control power of the servo drive.	
2	Set the Index 00 - Index 63 according to the index you wish to operate.	
3	For safety, set 1/10 of the value you wish to set for Velocity and Registration Velocity.	
4	Adjust the electronic gear ratio of the device to the upper device and set the [0x6091] gear ratio.	
5	Turn on the main circuit power of the servo drive.	
6	Turn on the SVON input signal.	
7	Turn the Start input signal ON->OFF.	
8	Check if the distance and registration distance values are displayed with the values set through the [0x6062] demand position value.	
9	Check the actual rotation amount of the motor with the [0x6064] actual position value.	
10	Check if steps 8 and 9 satisfy the formula shown below. $[0x6062] = [0x6064] \times [0x6091]$	
11	Check if the servo motor has performed the index operation in the commanded direction.	
12	Turn off the SVON input signal and change Velocity and Registration Velocity to the value that you wish to set. Then, perform steps 6 to 11.	
13	Turn off the SVON input signal.	

■ Objects to Inspect before the Test Drive

Index	Sub Index	Name	Variable type	Accessibility	PDO Assignment	Unit
0x2000	-	Motor ID	UINT	RW	No	-
0x2001	-	Encoder Type	UINT	RW	No	-
0x2002	-	Encoder Pulse per Revolution	UDINT	RW	No	pulse
0x2003	-	Node ID	UINT	RO	No	-
0x2004	-	Rotation Direction Select	UINT	RW	No	-
0x2013	-	Emergency Stop Configuration	UINT	RW	No	-
0x202A	-	Motor Encoder Configuration	UDINT	RW	No	-
0x2110	-	Torque Limit Function Select	UINT	RW	No	-
0x2111	-	External Positive Torque Limit Value	UINT	RW	No	-
0x2112	-	External Negative Torque Limit Value	UINT	RW	No	-
0x2113	-	Emergency Stop Torque	UINT	RW	No	0.1%
0x211F	-	Drive Control Input1	UINT	RW	No	-
0x2120	-	Drive Control Input2	UINT	RW	No	-
0x2121	-	Drive Status Output 1	UINT	RW	No	-
0x2121	-	Drive Status Output 2	UINT	RW	No	-
0x2200	-	Digital Input Signal 1 Selection	UINT	RW	No	-
0x2201	-	Digital Input Signal 2 Selection	UINT	RW	No	-
0x2202	-	Digital Input Signal 3 Selection	UINT	RW	No	-
0x2203	-	Digital Input Signal 4 Selection	UINT	RW	No	-
0x2210	-	Digital Output Signal 1 Selection	UINT	RW	No	-
0x2211	-	Digital Output Signal 2 Selection	UINT	RW	No	-
0x2212	-	Digital Output Signal 3 Selection	UINT	RW	No	-
0x2213	-	Digital Output Signal 4 Selection	UINT	RW	No	-
0x221C	-	Analog Torque Input(command/limit) Scale	UINT	RW	No	0.1%/V
0x221D	-	Analog Torque Input(command/limit) Offset	INT	RW	No	mV
0x221E	-	Analog Velocity Override Mode	UINT	RW	No	-

0x221F	-	Analog Input(command/override) Offset	Velocity	INT	RW	No	mV
0x222B	-	Analog Input Function Select		UINT	RW	No	-
0x240C	-	Modulo Factor		DINT	RW	No	-
0x3000	-	Control Mode		UINT	RW	No	-
0x3001	-	Coordinate Select		UINT	RW	No	-
0x3002	-	Baud Rate Select		UINT	RW	No	-
0x3006	-	Encoder Output Pulse		UDINT	RW	No	Pulse
0x3007	-	Encoder Output Mode		UINT	RW	No	
0x3008	-	Start Index Number(0~63)		UINT	RW	No	-
0x3009	-	Index Buffer Mode		UINT	RW	No	-
0x300A	-	IOUT Configuration		UINT	RW	No	-
0x2018	-	Magnetic Pole Pitch		UINT	RW	No	0.01mm
0x2019	-	Linear Scale Resolution		UINT	RW	No	nm
0x201A	-	Commutation Method		UINT	RW	No	-
0x201A	-	Commutation Method		UINT	RW	No	-
0x201B	-	Commutation Current		UINT	RW	No	0.1%
0x201C	-	Commutation Time		UINT	RW	No	ms
0x2020	-	Motor Hall Phase Config		UINT	RW	No	-
0x2800	-	[Third Party Motor] Type		UINT	RW	No	-
0x2801	-	[Third Party Motor] Number of Poles		UINT	RW	No	-
0x2802	-	[Third Party Motor] Rated Current		FP32	RW	No	Arms
0x2803	-	[Third Party Motor] Maximum Current		FP32	RW	No	Arms
0x2804	-	[Third Party Motor] Rated Speed		UINT	RW	No	rpm
0x2805	-	[Third Party Motor] Maximum Speed		FP32	RW	No	rpm
0x2806	-	[Third Party Motor] Inertia		FP32	RW	No	Kg.m2. 10-4
0x2807	-	[Third Party Motor] Torque Constant		FP32	RW	No	Nm/A
0x2808	-	[Third Party Motor] Phase resistance		FP32	RW	No	ohm
0x2809	-	[Third Party Motor] Phase Inductance		FP32	RW	No	mH
0x280A	-	[Third Party Motor] TN Curve Data 1		UINT	RW	No	rpm
0x280B	-	[Third Party Motor] TN Curve Data 2		FP32	RW	No	%
0x280C	-	[Third Party Motor] Hall Offset		UINT	RW	No	deg

Index	Sub Index	Name	Variable type	Accessibility	PDO Assignment	Unit
0x3100	-	Index 00	-	-	-	-
	0	Number of entries	USINT	RO	No	-
	1	Index Type	UINT	RW	No	-
	2	Distance	DINT	RW	No	UU
	3	Velocity	DINT	RW	No	UU/s
	4	Acceleration	DINT	RW	No	UU/s <sup>2</sup>
	5	Deceleration	DINT	RW	No	UU/s <sup>2</sup>



	6	Registration Distance	DINT	RW	No	UU
	7	Registration Velocity	DINT	RW	No	UU/s
	8	Repeat Count	UINT	RW	No	-
	9	Dwell Time	UINT	RW	No	ms
	10	Next Index	UINT	RW	No	-
	11	Action	UINT	RW	No	-
0x3101	-	Index 01	-	-	-	-
~						
0x313F	-	Index 63	-	-	-	-

## 13.5.2 Pulse Input Position Mode

### ■ Test Drive Procedure

Order	Handling	Notes
1	Check the power and input signal circuit again and turn on the control power of the servo drive.	
2	Set the [0x3003] input pulse logic according to the pulse output shape of the upper device.	
3	Set the command unit and adjust the electronic gear ratio [0x6091] according to the upper level device.	
4	Turn on the main circuit power of the servo drive.	
5	Turn on the SVON input signal.	
6	With the motor rotation amount that is easy to check, output the low speed pulse command to the upper level device. Set the motor speed for a command pulse speed less than 100 rpm for safety.	
7	With the [0x6062] demand position value, check the number of command pulses that are received.	
8	Check the actual rotation amount of the motor with the [0x6064] actual position value.	
9	Check if steps 7 and 8 satisfy the formula shown below. $[0x6062] = [0x6064] \times [0x6091]$	
10	Check if the servo motor has rotated in the commanded direction.	
11	Output the pulse command in the upper level device with the speed requested by the device.	
12	Check the speed, demand position value, and actual position value of the servo motor.	
13	Stop the pulse command and turn off the SVON input signal.	

■ Objects to Inspect before the Test Drive

Index	Sub Index	Name	Variable type	Accessability	PDO Assignment	Unit
0x2000	-	Motor ID	UINT	RW	No	-
0x2001	-	Encoder Type	UINT	RW	No	-
0x2002	-	Encoder Pulse per Revolution	UDINT	RW	No	pulse
0x2003	-	Node ID	UINT	RO	No	-
0x2004	-	Rotation Direction Select	UINT	RW	No	-
0x2013	-	Emergency Stop Configuration	UINT	RW	No	-
0x202A	-	Motor Encoder Configuration	UDINT	RW	No	-
0x2110	-	Torque Limit Function Select	UINT	RW	No	-
0x2111	-	External Positive Torque Limit Value	UINT	RW	No	-
0x2112	-	External Negative Torque Limit Value	UINT	RW	No	-
0x2113	-	Emergency Stop Torque	UINT	RW	No	0.1%
0x211F	-	Drive Control Input1	UINT	RW	No	-
0x2120	-	Drive Control Input2	UINT	RW	No	-
0x2121	-	Drive Status Output 1	UINT	RW	No	-
0x2121	-	Drive Status Output 2	UINT	RW	No	-
0x2200	-	Digital Input Signal 1 Selection	UINT	RW	No	-
0x2201	-	Digital Input Signal 2 Selection	UINT	RW	No	-
0x2202	-	Digital Input Signal 3 Selection	UINT	RW	No	-
0x2203	-	Digital Input Signal 4 Selection	UINT	RW	No	-
0x2210	-	Digital Output Signal 1 Selection	UINT	RW	No	-
0x2211	-	Digital Output Signal 2 Selection	UINT	RW	No	-
0x2212	-	Digital Output Signal 3 Selection	UINT	RW	No	-
0x2213	-	Digital Output Signal 4 Selection	UINT	RW	No	-
0x3000	-	Control Mode	UINT	RW	No	-
0x3001	-	Coordinate Select	UINT	RW	No	-

0x3002	-	Baud Rate Select	UINT	RW	No	-
0x3003	-	Pulse Input Logic Select	UINT	RW	No	-
0x3004	-	Pulse Input Filter Select	UINT	RW	No	-
0x3005	-	PCLEAR Mode Select	UINT	RW	No	-
0x3006	-	Encoder Output Pulse	UDINT	RW	No	Pulse
0x3007	-	Encoder Output Mode	UINT	RW	No	
0x2018	-	Magnetic Pole Pitch	UINT	RW	No	0.01m m
0x2019	-	Linear Scale Resolution	UINT	RW	No	nm
0x201A	-	Commutation Method	UINT	RW	No	-
0x201A	-	Commutation Method	UINT	RW	No	-
0x201B	-	Commutation Current	UINT	RW	No	0.1 %
0x201C	-	Commutation Time	UINT	RW	No	ms
0x2020	-	Motor Hall Phase Config	UINT	RW	No	-
0x2800	-	[Third Party Motor] Type	UINT	RW	No	-
0x2801	-	[Third Party Motor] Number of Poles	UINT	RW	No	-
0x2802	-	[Third Party Motor] Rated Current	FP32	RW	No	Arms
0x2803	-	[Third Party Motor] Maximum Current	FP32	RW	No	Arms
0x2804	-	[Third Party Motor] Rated Speed	UINT	RW	No	rpm
0x2805	-	[Third Party Motor] Maximum Speed	FP32	RW	No	rpm
0x2806	-	[Third Party Motor] Inertia	FP32	RW	No	Kg.m <sup>2</sup> · 10 <sup>-4</sup>
0x2807	-	[Third Party Motor] Torque Constant	FP32	RW	No	Nm/A
0x2808	-	[Third Party Motor] Phase resistance	FP32	RW	No	ohm
0x2809	-	[Third Party Motor] Phase Inductance	FP32	RW	No	mH
0x280A	-	[Third Party Motor] TN Curve Data 1	UINT	RW	No	rpm
0x280B	-	[Third Party Motor] TN Curve Data 2	FP32	RW	No	%
0x280C	-	[Third Party Motor] Hall Offset	UINT	RW	No	deg

## 13.5.3 Speed Mode

### ■ Test Drive Procedure

Order	Handling	Notes
1	Check the power and input signal circuit again and turn on the control power of the servo drive.	
2	Set the [0x231A] speed command switch select function according to the control method.	
3	When controlling with a digital input signal, set the multi-stage operation speed and digital input signal setting parameters. In an analog speed operation, set the [0x2229] analog speed command scale and the [0x222A] analog speed command clamp level parameter. Set the value 1/10 lower than the actual operation speed.	
4	Turn on the main circuit power of the servo drive.	
5	Turn on the SVON input signal.	
6	Send the command signal to the servo drive and check the actual operating speed and command speed.	
7	Check if the servo motor has rotated in the commanded direction.	
8	Output it in the upper level device with the speed requested by the device.	
9	Check the speed of the servo motor.	
10	Stop the command and turn off the SVON input signal.	

**■ Objects to Inspect before the Test Drive**

Index	Sub Index	Name	Variable type	Accessi- bility	PDO Assign- ment	Unit
0x2000	-	Motor ID	UINT	RW	No	-
0x2001	-	Encoder Type	UINT	RW	No	-
0x2002	-	Encoder Pulse per Revolution	UDINT	RW	No	pulse
0x2003	-	Node ID	UINT	RO	No	-
0x2004	-	Rotation Direction Select	UINT	RW	No	-
0x2013	-	Emergency Stop Configuration	UINT	RW	No	-
0x202A	-	Motor Encoder Configuration	UDINT	RW	No	-
0x2110	-	Torque Limit Function Select	UINT	RW	No	-
0x2111	-	External Positive Torque Limit Value	UINT	RW	No	-
0x2112	-	External Negative Torque Limit Value	UINT	RW	No	-
0x2113	-	Emergency Stop Torque	UINT	RW	No	0.1%
0x211F	-	Drive Control Input1	UINT	RW	No	-
0x2120	-	Drive Control Input2	UINT	RW	No	-
0x2121	-	Drive Status Output 1	UINT	RW	No	-
0x2121	-	Drive Status Output 2	UINT	RW	No	-
0x2200	-	Digital Input Signal 1 Selection	UINT	RW	No	-
0x2201	-	Digital Input Signal 2 Selection	UINT	RW	No	-
0x2202	-	Digital Input Signal 3 Selection	UINT	RW	No	-
0x2203	-	Digital Input Signal 4 Selection	UINT	RW	No	-
0x2210	-	Digital Output Signal 1 Selection	UINT	RW	No	-
0x2211	-	Digital Output Signal 2 Selection	UINT	RW	No	-
0x2212	-	Digital Output Signal 3 Selection	UINT	RW	No	-
0x2213	-	Digital Output Signal 4 Selection	UINT	RW	No	-
0x221C	-	Analog Torque Input(command/limit) Scale	UINT	RW	No	0.1%/V
0x221D	-	Analog Torque Input(command/limit) Offset	INT	RW	No	mV
0x221E	-	Analog Velocity Override Mode	UINT	RW	No	-
0x221F	-	Analog Velocity Input(command/override) Offset	INT	RW	No	mV

0x2227	-	Analog Velocity Command Filter Time Constant	UINT	RW	No	0.1ms
0x222A	-	Analog Velocity Command Clamp Level	UINT	RW	No	rpm
0x222B	-	Analog Input Function Select	UINT	RW	No	-
0x2301	-	Speed Command Acceleration Time	UINT	RW	No	ms
0x2302	-	Speed Command Deceleration Time	UINT	RW	No	ms
0x2303	-	Speed Command S-curve Time	UINT	RW	No	ms
0x230D	-	Speed Limit Funcion Select	UINT	RW	No	-
0x2312	-	Multi-Step Operation Speed1	INT	RW	No	rpm
0x2313	-	Multi-Step Operation Speed2	INT	RW	No	rpm
0x2314	-	Multi-Step Operation Speed3	INT	RW	No	rpm
0x2316	-	Multi-Step Operation Speed5	INT	RW	No	rpm
0x2317	-	Multi-Step Operation Speed6	INT	RW	No	rpm
0x2318	-	Multi-Step Operation Speed7	INT	RW	No	rpm
0x2319	-	Multi-Step Operation Speed8	INT	RW	No	rpm
0x231A	-	Velocity Command Switch Select	UINT	RW	No	-
0x3000	-	Control Mode	UINT	RW	No	-
0x3002	-	Baud Rate Select	UINT	RW	No	-
0x3006	-	Encoder Output Pulse	UDINT	RW	No	Pulse
0x3007	-	Encoder Output Mode	UINT	RW	No	
0x2018	-	Magnetic Pole Pitch	UINT	RW	No	0.01m m
0x2019	-	Linear Scale Resolution	UINT	RW	No	nm
0x201A	-	Commutation Method	UINT	RW	No	-
0x201A	-	Commutation Method	UINT	RW	No	-
0x201B	-	Commutation Current	UINT	RW	No	0.1%
0x201C	-	Commutation Time	UINT	RW	No	ms
0x2020	-	Motor Hall Phase Config	UINT	RW	No	-
0x2800	-	[Third Party Motor] Type	UINT	RW	No	-
0x2801	-	[Third Party Motor] Number of Poles	UINT	RW	No	-
0x2802	-	[Third Party Motor] Rated Current	FP32	RW	No	Arms
0x2803	-	[Third Party Motor] Maximum Current	FP32	RW	No	Arms
0x2804	-	[Third Party Motor] Rated Speed	UINT	RW	No	Rpm
0x2805	-	[Third Party Motor] Maximum Speed	FP32	RW	No	Rpm
0x2806	-	[Third Party Motor] Inertia	FP32	RW	No	Kg.m2 10-4

0x2807	-	[Third Party Motor] Torque Constant	FP32	RW	No	Nm/A
0x2808	-	[Third Party Motor] Phase resistance	FP32	RW	No	Ohm
0x2809	-	[Third Party Motor] Phase Inductance	FP32	RW	No	mH
0x280A	-	[Third Party Motor] TN Curve Data 1	UINT	RW	No	rpm
0x280B	-	[Third Party Motor] TN Curve Data 2	FP32	RW	No	%
0x280C	-	[Third Party Motor] Hall Offset	UINT	RW	No	deg



## 13.5.4 Torque Operation

### ■ Test Drive Procedure

Order	Handling	Notes
1	Check the power and input signal circuit again and turn on the control power of the servo drive.	
2	Set the [0x221C] analog torque command scale.	
3	Set the limit speed value for [0x230E] torque control. Set the value to 1/10 of the actual operation voltage.	
4	Turn on the main circuit power of the servo drive.	
5	Turn on the SVON input signal.	
6	Apply analog voltage to the servo drive to check the speed and command torque values.	
7	Check if the servo motor has rotated in the commanded direction.	
8	Output it in the upper level device with the speed requested by the device.	
9	Check the speed of the servo motor and command torque value.	
10	Stop the command and turn off the SVON input signal.	

**■ Objects to Inspect before the Test Drive**

Index	Sub Index	Name	Variable type	Accessi- bility	PDO Assign- ment	Unit
0x2000	-	Motor ID	UINT	RW	No	-
0x2001	-	Encoder Type	UINT	RW	No	-
0x2002	-	Encoder Pulse per Revolution	UDINT	RW	No	pulse
0x2003	-	Node ID	UINT	RO	No	-
0x2004	-	Rotation Direction Select	UINT	RW	No	-
0x2013	-	Emergency Stop Configuration	UINT	RW	No	-
0x202A	-	Motor Encoder Configuration	UDINT	RW	No	-
0x2110	index-	Torque Limit Function Select	UINT	RW	No	-
0x2111	index-	External Positive Torque Limit Value	UINT	RW	No	-
0x2112	index-	External Negative Torque Limit Value	UINT	RW	No	-
0x2113	index-	Emergency Stop Torque	UINT	RW	No	0.1%
0x211F	-	Drive Control Input1	UINT	RW	No	-
0x2120	-	Drive Control Input2	UINT	RW	No	-
0x2121	-	Drive Status Output 1	UINT	RW	No	-
0x2121	-	Drive Status Output 2	UINT	RW	No	-
0x2200	-	Digital Input Signal 1 Selection	UINT	RW	No	-
0x2201	-	Digital Input Signal 2 Selection	UINT	RW	No	-
0x2202	-	Digital Input Signal 3 Selection	UINT	RW	No	-
0x2203	-	Digital Input Signal 4 Selection	UINT	RW	No	-
0x220D	-	Digital Input Signal 13 Selection	UINT	RW	No	-
0x220E	-	Digital Input Signal 14 Selection	UINT	RW	No	-
0x220F	-	Digital Input Signal 15 Selection	UINT	RW	No	-
0x2210	-	Digital Output Signal 1 Selection	UINT	RW	No	-
0x2211	-	Digital Output Signal 2 Selection	UINT	RW	No	-
0x2212	-	Digital Output Signal 3 Selection	UINT	RW	No	-
0x2213	-	Digital Output Signal 4 Selection	UINT	RW	No	-
0x221C	-	Analog Torque Input(command/limit) Scale	UINT	RW	No	0.1%/V
0x221D	-	Analog Torque Input(command/limit) Offset	INT	RW	No	mV
0x2228	-	Analog Torque Command Filter Time Constant	UINT	RW	No	0.1ms

0x222B	-	Analog Input Function Select	UINT	RW	No	-
0x2301	-	Speed Command Acceleration Time	UINT	RW	No	ms
0x2302	-	Speed Command Deceleration Time	UINT	RW	No	ms
0x2228	-	Analog Torque Command Filter Time Constant	UINT	RW	No	0.1ms
0x230E	-	Speed Limit Value at Torque Control Mode	UINT	RW	No	-
0x3000	-	Control Mode	UINT	RW	No	-
0x3002	-	Baud Rate Select	UINT	RW	No	-
0x3006	-	Encoder Output Pulse	UDINT	RW	No	Pulse
0x3007	-	Encoder Output Mode	UINT	RW	No	
0x2018	-	Magnetic Pole Pitch	UINT	RW	No	0.01m m
0x2019	-	Linear Scale Resolution	UINT	RW	No	nm
0x201A	-	Commutation Method	UINT	RW	No	-
0x201A	-	Commutation Method	UINT	RW	No	-
0x201B	-	Commutation Current	UINT	RW	No	0.1%
0x201C	-	Commutation Time	UINT	RW	No	ms
0x2020	-	Motor Hall Phase Config	UINT	RW	No	-
0x2800	-	[Third Party Motor] Type	UINT	RW	No	-
0x2801	-	[Third Party Motor] Number of Poles	UINT	RW	No	-
0x2802	-	[Third Party Motor] Rated Current	FP32	RW	No	Arms
0x2803	-	[Third Party Motor] Maximum Current	FP32	RW	No	Arms
0x2804	-	[Third Party Motor] Rated Speed	UINT	RW	No	rpm
0x2805	-	[Third Party Motor] Maximum Speed	FP32	RW	No	rpm
0x2806	-	[Third Party Motor] Inertia	FP32	RW	No	Kg.m2 .10-4
0x2807	-	[Third Party Motor] Torque Constant	FP32	RW	No	Nm/A
0x2808	-	[Third Party Motor] Phase resistance	FP32	RW	No	ohm
0x2809	-	[Third Party Motor] Phase Inductance	FP32	RW	No	mH
0x280A	-	[Third Party Motor] TN Curve Data 1	UINT	RW	No	rpm
0x280B	-	[Third Party Motor] TN Curve Data 2	FP32	RW	No	%
0x280C	-	[Third Party Motor] Hall Offset	UINT	RW	No	deg

# 14. Appendix

## 14.1 Firmware Update

### 14.1.1 Use of USB OTG

The drive performs a USB host function to search for firmware files in the USB memory and download them to the flash memory inside the drive. You can easily update the firmware using the USB memory and OTG cable without a PC. The update procedure is as follows:

- (1) Prepare a download cable (USB OTG cable) and a USB memory.

Use a USB OTG cable, consisting of a USB Female Plug Type A and USB Mini B 5 pins, as the download cable.



- (2) Copy the firmware file (PHOX\_FW.bin) to update to the USB memory.

**\*Note: The USB memory should be formatted in "FAT32". Also, there should be the PHOX\_FW.bin file in the root directory and the entire name including file extension should match. (However, the file name is not case-sensitive.)**

- (3) After connecting the USB memory to the USB OTG cable, connect it to the USB terminal and power on the drive.
- (4) If the servo status display LED is flickering red, the firmware is being updated. If the servo status display LED returns to normal, remove the USB OTG cable and USB memory.
- (5) Turn on the power again, and verify if the firmware is updated.

## 14.1.2 Use of Drive CM

'Drive CM allows the OS upgrade for the drive through the PC's USB port. The transmission time depends on the PC performance, but it usually takes several seconds to several minutes.



From the top menu, click Setup -> FIRMWARE UPGRADE -> OS Download.

### ■ Precautions for Firmware Upgrade

- Do not turn off the PC or drive during transmission.
- Do not unplug the USB cable or close the firmware program during transmission.
- Do not run other applications on the PC during transmission.
- The parameter (object) settings in the drive can be initialized. Be sure to save the settings for the drive parameters (objects) before upgrading.

## ■ Firmware Download

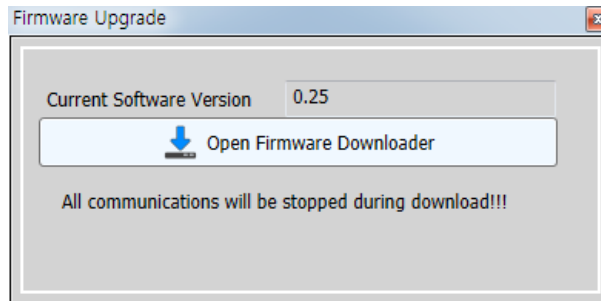

(1) Click the Open Firmware Downloader button.

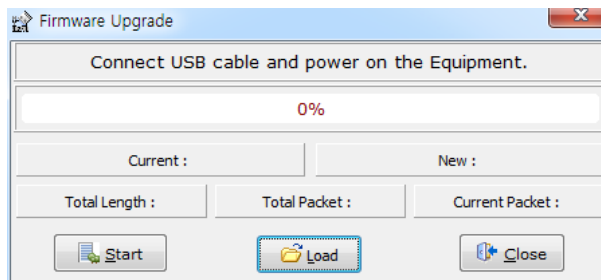

(2) To load the appropriate firmware file, click the Load button.

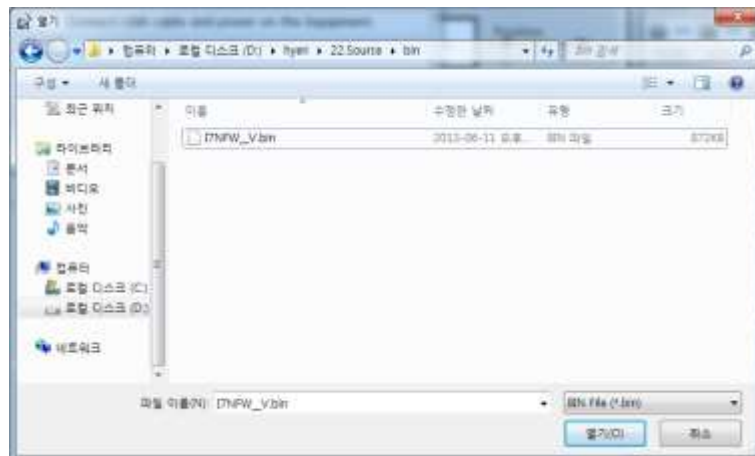

(3) Select the BIN file of the firmware to transmit and click Open.

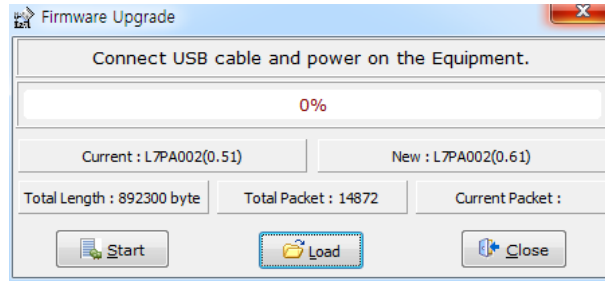

- (4) The loaded firmware's total length and total packet are displayed. Compare the current name with the new name to check the drive type, capacity, and firmware version.

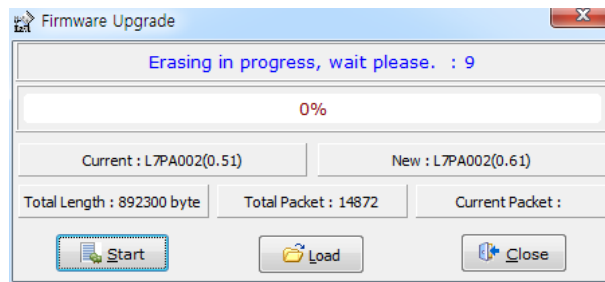

- (5) Click Start to begin transmission. 10 seconds are counted down to clear the internal memory in the drive. (For L7NH and L7P, the segment 7 should display "USB". For PEGASUS, a red "ERR" LED should be illuminated.)

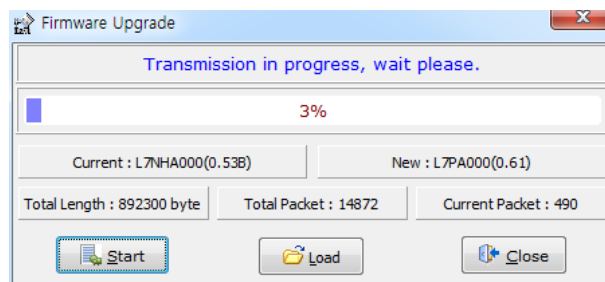

- (6) After clearing, the firmware is transmitted automatically, and the progress bar and "Current Packet" display the current transmission status. (The transmission time depends on the PC performance, but it usually takes several seconds to several minutes.)

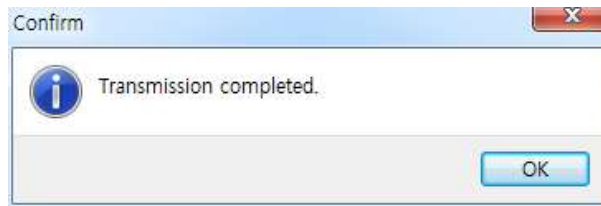

- (7) When the transmission is completed, a "Transmission completed" dialog box appears. (When transmission to the PC is completed, turn the drive off and on to restart.)

### ■ An Error Occurs During Transmission

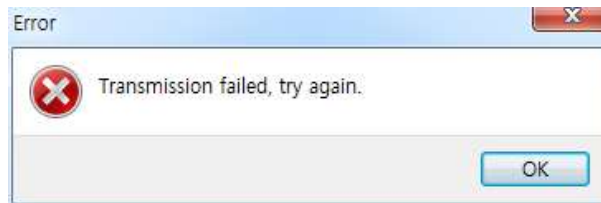

- (1) Turn the drive off and on and repeat the above process from (2) to (7).

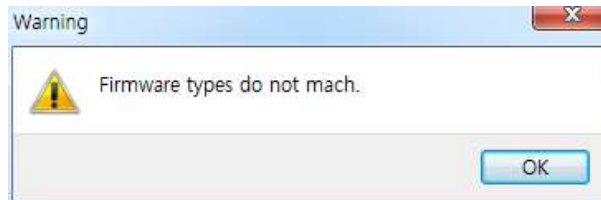

- (1) Check the drive type and capacity of the firmware you wish to transmit.



- (1) Check the firmware version. You cannot download a version that is lower than the current version.



# Quality Assurance

<b>Product Name</b>	LS Mecapion Servo Drive		<b>Date of Installation</b>	
<b>Model name</b>	<i>PHOENIX Series</i>		<b>Warranty Period</b>	
<b>Customer</b>	<b>Name</b>			
	<b>Address</b>			
	<b>Phone</b>			
<b>Retailer</b>	<b>Name</b>			
	<b>Address</b>			
	<b>Phone</b>			

This product was produced using strict quality control and testing procedures developed by LS Mecapion technicians.  
 The warranty applies for 12 months after the date of installation. The warranty is valid for 18 months after the date of manufacture if the installation date is not filled out. However, the term of this warranty may change depending on the terms of the contract.

### Free Technical Support

If the drive malfunctions under proper usage conditions and the product warranty is still valid, contact one of our agencies or designated service centers. We will repair the drive free of charge.

### Paid Technical Support

The warranty does not cover technical support if:

- The malfunction is the result of negligence on the part of the consumer.
- The malfunction is the result of inappropriate voltage or defects in the machines connected to the product.
- The malfunction is the result of an act of god (fire, flood, gas, earthquake, etc.).
- The product was modified or repaired by someone other than our agency or service center.
- The LS Mecapion name tag is not attached to the product.
- The warranty has expired.

※ After installing the servo, fill out this quality assurance form and send it to our quality assurance department (technical support).

Send to: LS Mecapion Quality Assurance Service  
 Phone: 82.53.593.0066 (154) Fax: 82.53.591.8614

Visit the LS Mecapion homepage (<http://www.lsmecapion.com>) for more information and services.

# User Manual Revision History

Number	Date issued	Revised content	Version number	Notes
1	2016.06.16	First edition was distributed	1.0	
2				
3				
4				
5				
6				
7				
8				
9				

<h3 style="text-align: center;">Green Management</h3> <p>LS Mecapion considers protecting the environment a high priority. We work hard to protect the Earth.</p>		<h3 style="text-align: center;">Product Disposal</h3> <p>The LS Mecapion servo drive is environmentally friendly. You can disassemble the drive and recycle the iron, aluminum, bronze, and synthetic resin (cover) components.</p>
---	--	---