

# Shift Chain - Enclosed roller skid type

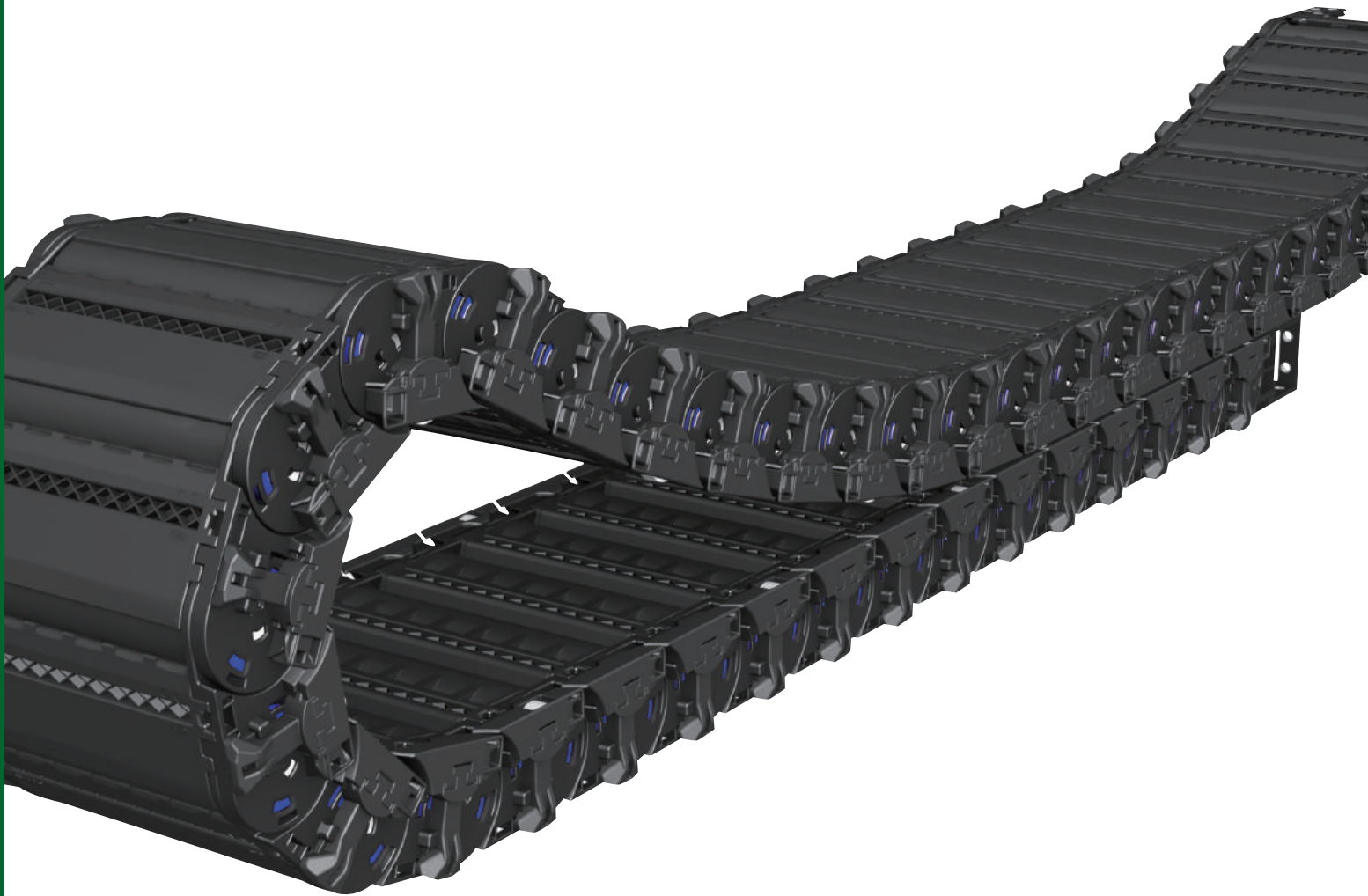

## » General information

Item	Value
Material	CPS-Amid(PA6+GF), RoHs
Speed	3m/s
Acceleration	10m/s <sup>2</sup>
Temperature	-30°C ~+130°C
Certificate	CE, ATEX(Ex)

## » Calculation table

Item	Value
Length of Cable Chain	$L = \frac{1}{2} \times LS + LP$
Bending Radius	
The biggest Cable inserted	Multiply 8~10 and the biggest cable
The biggest Hydraulic Hose inserted	Multiply 15~20 and the biggest hose

## » Dimension table

Shift Chain ERS Type	Pitch	Bending Radius (R)	Weight kg/m	Speed m/s	Temperature °C	Clearance				Frame style	Divider possible with frame
						A	B	C	D		
ST 044ERS	44	70, 90, 120, 150	1.07	3	-30 ~ +130	73	40.5	35	24.5		
			1.16			93		55			
			1.23			113		75			
			1.33			138		100			
ST 072ERS	72	120, 145, 200, 250, 300	2.53	3	-30 ~ +130	104	69	50	44		
			2.65			129		75			
			2.77			154		100			
			2.89			179		125			
			3.01			204		150			
ST 095ERS	95	150, 200, 230, 280, 400	4.20	3	-30 ~ +130	168	85	100	55		
			4.45			193		125			
			4.70			218		150			
			4.95			243		175			
			5.19			268		200			
ST 120ERS	120	200, 250, 300, 350, 400, 500	5.17	3	-30 ~ +130	218	112	150	76		
			5.48			268		200			
			5.78			318		250			
			6.09			368		300			
ST 150ERS	150	305, 405, 505, 605	10.23	3	-30 ~ +130	287	145	200	110		
			10.84			337		250			
			11.45			387		300			
			12.06			437		350			
			12.67			487		400			

(Dimensions in mm)

## » Ordering

**ST 044ERS, 100, R120 / F - 1500L : 10ST**

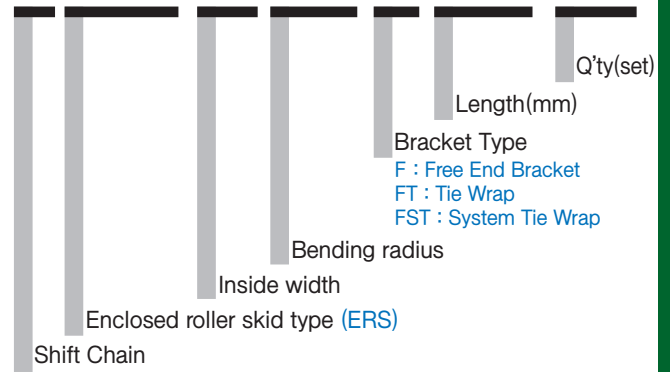

## » Bracket type

- ST044, ST072, ST095, ST120

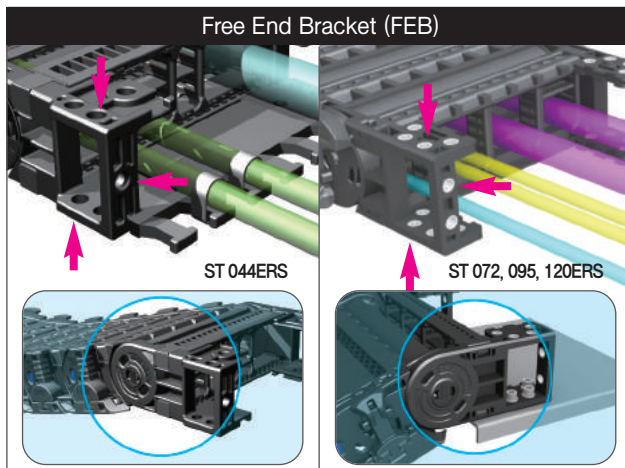

- ▶ BR should not be inserted in the joint of side band and Free End Bracket.
- ▶ Normal Frame, not FRU/FRD, is inserted into Free End Bracket.

# Shift Chain - Enclosed roller skid type

## >> Part of Shift Chain Enclosed Roller skid type

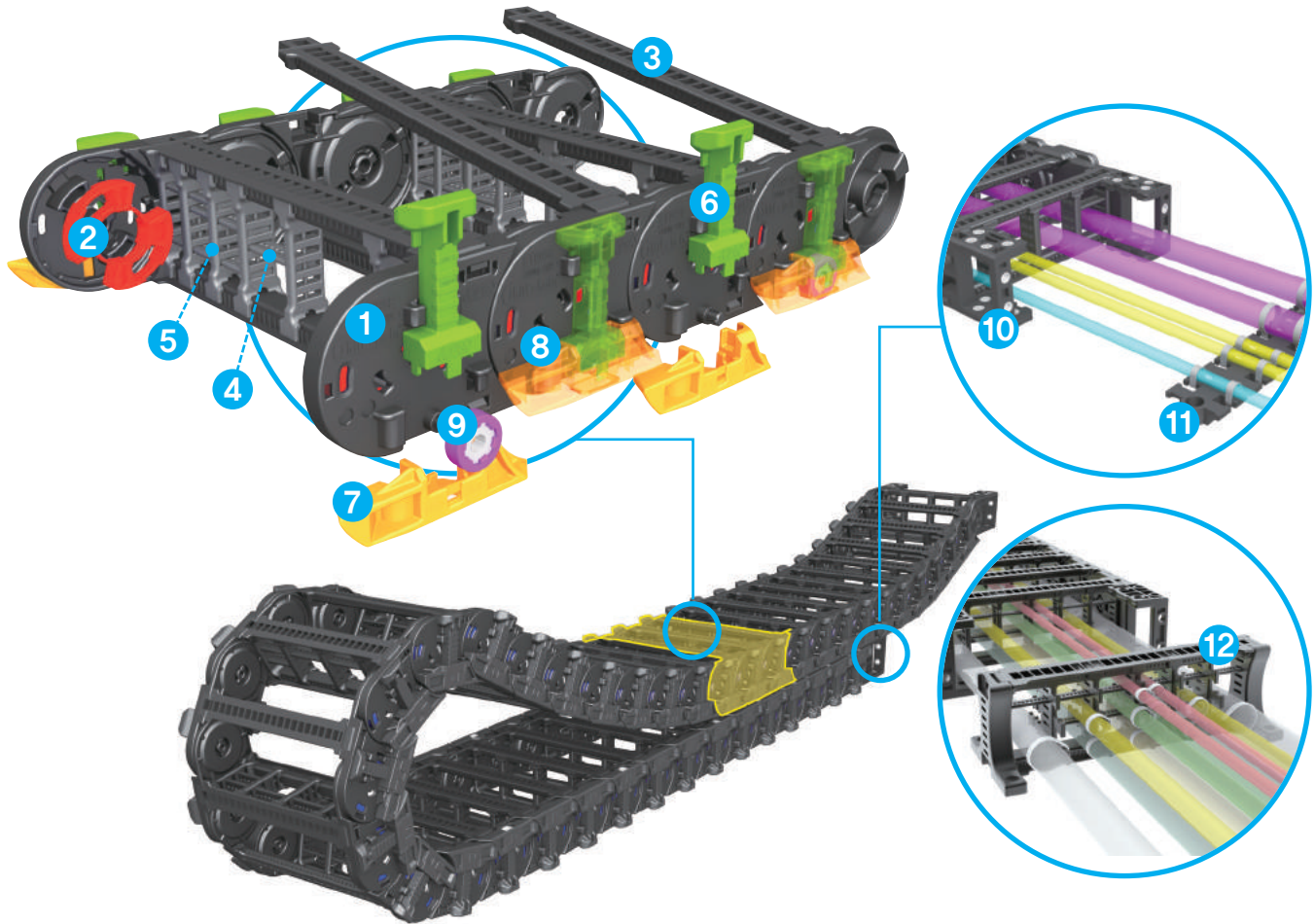

### 1 Side Band (SB)

A unit that connects each side band and between them BR is inserted to strengthen clamping force.

### 2 Bending Radius Unit (BR)

A unit that inserted between each side band, There are 6 supporting points to create durability.

### 3 FRU, FRD [FRU(D) Enclosed type applicable]

A unit that connects left and right side band and there are 2 types of frame : FRU, FRD.

### 4 Separator (SP)

A unit that divides inserted cables vertically to prevent twisting and breaking problem.

### 5 Divider (DV-S, M, R, T)

A unit that divides inserted cables horizontally.

### 6 Support

A unit that supports skid & roller skid which makes skid & roller skid move up and down.

### 7 8 Skid, Roller Skid

Skid : A unit that minimizes friction between upper and lower cable chain.  
Roller Skid : A unit that minimizes friction between upper and lower cable chain, while roller is combined type..

### 9 Roller

A unit that minimizes friction between upper and lower cable chain. It contains bearing in the core.

### 10 Free End Bracket (FEB)

A unit that connects at last side band (left&right). It can be fixed stronger using steel washers.

### 11 Tie Wrap (TW)

A unit that ties cables to maintain straightness of them. It can be assembled to bracket directly or installed separately from bracket.

### 12 System Tie Wrap (STW)

System-Tie Wrap has to be assembled on fixing and moving point of bracket and can be assembled without any tie wrap plate. This tie wrap is used to stay the cables on several floors prevent the cables from being twisted and it can also be assemble without any tools or bolt. This tie wrap has two types, one is to assemble inside bracket the other one is outside.



## » Assembly procedure of Shift Chain Enclosed Roller skid type

Assembly procedure of Shift chain ERS-type is as follows. The assembling process of shift Chain ERS-type is like below and users must use rubber hammer with careful combination of Divider and Separator. (Disassembly process for repair and replacement is in reverse order)



**1**  
Insert BR Unit into each Side Band.  
(Side Band is divided into right and left side according to the direction.)

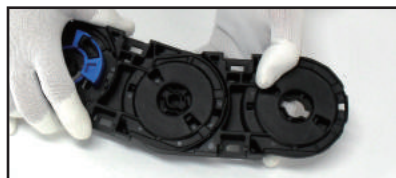

**2**  
Continue to insert BR Unit into Side Band as you want to make it, Assembly Side Band which is inserted BR Unit as above.



**3**  
Continue to connect each Side Band as long as you want to make it.



**4**  
Connect the Side Band as many as you need.

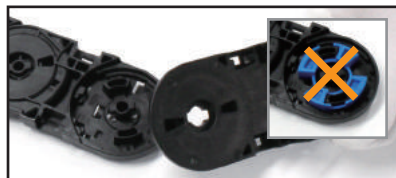

**5**  
Assemble the F.FEB according to the direction of right and left side. (Do not insert the BR Unit to Side Band connected to F.FEB, Side of F.FEB is not enclosed.)

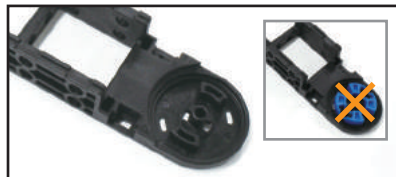

**6**  
Do not insert a BR to M.FEB.  
(M.FEB will be making a turn to up and down.)



**7**  
Assemble the M.FEB according to the direction of right and left side.  
(Side of M.FEB is not enclosed.)

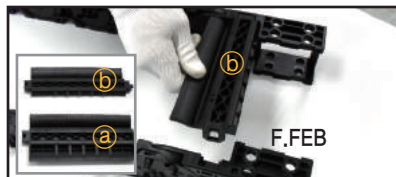

**8**  
Insert one (b) Shaped-FRD into F.FEB. (a: Normal FRD (b): Built-up only for F.FEB) Find one (b) shaped-FRD and insert it with the hinge facing RH direction, as above.

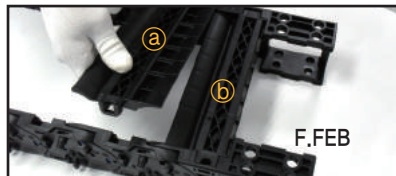

**9**  
Continue to insert the FRD (a: Normal FRD) with the hinge facing RH direction.  
(Assemble the from F.FEB to M.FEB in order.)



**10**  
Insert the frame as many as you need and insert them one by one with the hinge facing RH direction, as above.  
(M.FEB is not turned to up and down when FRD assembling.)



**11**  
Insert the (b) shaped-FRD inserted to F.FEB and insert it with the hinge facing RH direction, as above. (a: Normal FRD (b): Built-up only for F.FEB) Insert the divider with separator to divide the inside of chain.

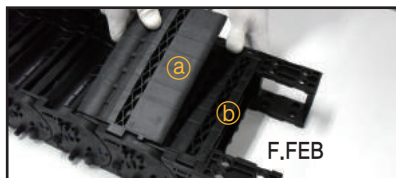

**12**  
Continue to insert the FRU (a: Normal FRU) with the hinge facing RH direction. (Assemble the from F.FEB to M.FEB in order.)

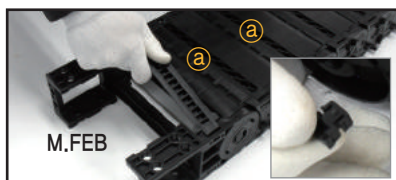

**13**  
Insert (a) Normal FRU as many as you need and insert them one by one with the hinge facing RH direction, as above. Insert Frame-pin into the hole which is seen where the end of FRU and Side Band meet. (M.FEB is not turning to up and down when FRU assembling.)



**14**  
Insert Roller into mounted Side Band.



**15**  
Continue to insert Roller into Side Band.  
Basically, you insert one roller per 4 Link.



**16**  
Insert Roller Skid into Side Band where roller inserted in.  
Skid is divided into Roller Skid (Skid with mount for roller) and normal Skid. (Skid without mount)

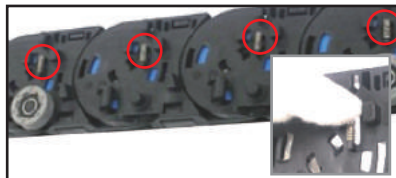

**17**  
Insert support into groove of side band until you hear the "click". (Same support for both LH and RH.)

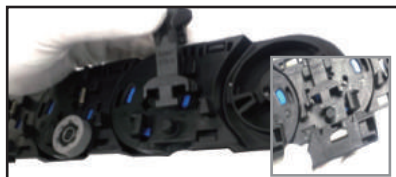

**18**  
Insert a normal Skid into Side Band which is not inserted a roller.



**19**  
Insert Skid and Support into all Side Band links. (Check that Skid is working up-and-down properly when you push the assembled Skids by hands.)

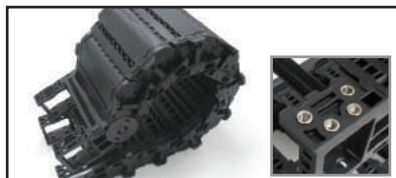

**20**  
Insert steel washers into M.FEB and F.FEB.



# Shift Chain - Enclosed roller skid type

## » Part of Shift Chain Enclosed Roller skid type

- Composition of Cable chain(Standard)  
= Side band(RH) + Frame + Side band(LH) + Bending radius Unit + Free end bracket
- M divider(normal divider) should be applied every second frames to make a section composition.
- ※ Please refer to below part list and description to understand composition of cable chain.

Model	Classification	Part number	Description
ST044ERS	SIDE BAND	ST-SB044S(LH) ST-SB044S(RH)	Left side band of ST044S Right side band of ST044S
	BENDING RADIUS	ST-BRS044.R70, 90, 120, 150	Bending radius unit for side band
	SKID	ST-SK044RS(LH-N) ST-SK044RS(LH-R) ST-SK044RS(RH-N) ST-SK044RS(RH-R)	Skid for long travel(Applied to side band)
	SPRING	ST-SPR044	Supporter to fix skid unit
	SUPPORT	ST-SUP044	Spring with roller
	ROLLER	ST-RL044	Roller for long travel(Applied to side band)
	FRAME(DOWN) FRAME(UP)	ST-FRD044.35 ST-FRU044.35 ST-FRD044.55 ST-FRU044.55 ST-FRD044.75 ST-FRU044.75 ST-FRD044.100 ST-FRU044.100	Inside frame, 35mm Outside frame, 35mm Inside frame, 55mm Outside frame, 55mm Inside frame, 75mm Outside frame, 75mm Inside frame, 100mm Outside frame, 100mm
	FRAME(DOWN-FIXING END) FRAME(UP-FIXING END) FRAME(DOWN-MOVING END) FRAME(UP-MOVING END)	ST-FRD044.35,55,75,100 ST-FRU044.35,55,75,100 ST-FRD044.35,55,75,100 ST-FRU044.35,55,75,100	Inside half-frame for fixing end bracket Outside half-frame for fixing end bracket Inside half-frame for moving end bracket Outside half-frame for moving end bracket
	FREE END BRACKET	ST-FEB044E	End bracket of ST044E
	DIVIDER	sb-DV028/M sb-DV028/S	Normal divider To fix separstors at the both side section
	SEPARATOR	S-SP/M.35 S-SP/M.50 S-SP/M.75 S-SP/M.100	Separator, 35mm Separator, 50mm Separator, 75mm Separator, 100mm
	TIE WRAP	S-TW036/025CR.35 S-TW036/025CR.55 S-TW036/025CR.75 S-TW036/025CR.100 S-TW036/025CR.125	Tie wrap for end bracket to fix cables, 35mm Tie wrap for end bracket to fix cables, 55mm Tie wrap for end bracket to fix cables, 75mm Tie wrap for end bracket to fix cables, 100mm Tie wrap for end bracket to fix cables, 125mm
	SYSTEM TIE WRAP	sb-DV028/W S-TW.EB028	Divider for fixing cables at end bracket System tie wrap to arrange for cables right after moving bracket or fixing bracket

Model	Classification	Part number	Description
ST072ERS	SIDE BAND	ST-SB072S(LH) ST-SB072S(RH)	Left side band of ST072S Right side band of ST072S
	BENDING RADIUS	ST-BRS072. R120,145,200,250,300	Bending radius unit for side band
	SKID	ST-SK072RS(LH-N) ST-SK072RS(LH-R) ST-SK072RS(RH-N) ST-SK072RS(RH-R)	Skid for long travel(Applied to side band)
	SPRING	ST-SPR072	Supporter to fix skid unit
	SUPPORT	ST-SUP072	Spring with roller
	ROLLER	ST-RL072	Roller for long travel(Applied to side band)
	FRAME PIN	S-FP/S1	Frame pin
	FRAME(DOWN) FRAME(UP)	ST-FRD072.50 ST-FRU072.50 ST-FRD072.75 ST-FRU072.75 ST-FRD072.100 ST-FRU072.100 ST-FRD072.125 ST-FRU072.125 ST-FRD072.150 ST-FRU072.150	Inside frame, 50mm Outside frame, 50mm Inside frame, 75mm Outside frame, 75mm Inside frame, 100mm Outside frame, 100mm Inside frame, 125mm Outside frame, 125mm Inside frame, 150mm Outside frame, 150mm
	FRAME(DOWN-FIXING END) FRAME(UP-FIXING END) FRAME(DOWN-MOVING END) FRAME(UP-MOVING END)	ST-FRD072.50,75,100,125,150 ST-FRU072.50,75,100,125,150 ST-FRD072.50,75,100,125,150 ST-FRU072.50,75,100,125,150	Inside half-frame for fixing end bracket Outside half-frame for fixing end bracket Inside half-frame for moving end bracket Outside half-frame for moving end bracket
	FREE END BRACKET	ST-FEB072 sb-FEB/WH045	End bracket of ST072E Steel washer for end bracket
	DIVIDER	sb-DV045/M sb-DV045/S	Normal divider To fix separstors at the both side section
	SEPARATOR	sb-SP/400.400 SP-PIN045	Separator, 400mm Separator pin to fix
	TIE WRAP	S-TW50 S-TW75 S-TW100 S-TW125 S-TW150	Tie wrap for end bracket to fix cables, 50mm Tie wrap for end bracket to fix cables, 75mm Tie wrap for end bracket to fix cables, 100mm Tie wrap for end bracket to fix cables, 125mm Tie wrap for end bracket to fix cables, 150mm
SYSTEM TIE WRAP	sb-DV045/W S-TW.EB045	Divider for fixing cables at end bracket System tie wrap to arrange for cables right after moving bracket or fixing bracket	

Model	Classification	Part number	Description
ST095ERS	SIDE BAND	ST-SB095S(LH) ST-SB095S(RH)	Left side band of ST095S Right side band of ST095S
	BENDING RADIUS	ST-BR095.R150,200,230,280,400	Bending radius unit for side band
	SKID	ST-SK095RS(LH-N) ST-SK095RS(LH-R) ST-SK095RS(RH-N) ST-SK095RS(RH-R)	Skid for long travel(Applied to side band)
	SPRING	ST-SPR095	Supporter to fix skid unit
	SUPPORT	ST-SUP095	Spring with roller
	ROLLER	ST-RL095	Roller for long travel(Applied to side band)
	FRAME PIN	S-FP/S1	Frame pin
	FRAME(DOWN) FRAME(UP)	ST-FRD095,100 ST-FRU095,100 ST-FRD095,125 ST-FRU095,125 ST-FRD095,150 ST-FRU095,150 ST-FRD095,175 ST-FRU095,175 ST-FRD095,200 ST-FRU095,200	Inside frame, 100mm Outside frame, 100mm Inside frame, 125mm Outside frame, 125mm Inside frame, 150mm Outside frame, 150mm Inside frame, 175mm Outside frame, 175mm Inside frame, 200mm Outside frame, 200mm
	FRAME(DOWN-FIXING END) FRAME(UP-FIXING END) FRAME(DOWN-MOVING END) FRAME(UP-MOVING END)	ST-FRD095,100,125,150,175,200 ST-FRU095,100,125,150,175,200 ST-FRD095,100,125,150,175,200 ST-FRU095,100,125,150,175,200	Inside half-frame for fixing end bracket Outside half-frame for fixing end bracket Inside half-frame for moving end bracket Outside half-frame for moving end bracket
	FREE END BRACKET	ST-FEB095E	End bracket of ST095E
	DIVIDER	sb-DV060/M sb-DV060/S	Normal divider To fix separstors at the both side section
	SEPARATOR	sb-SP/400,400 SP-PIN060	Separator, 400mm Separator pin to fix
	TIE WRAP	S-TW50 S-TW75 S-TW100 S-TW125 S-TW150	Tie wrap for end bracket to fix cables, 50mm Tie wrap for end bracket to fix cables, 75mm Tie wrap for end bracket to fix cables, 100mm Tie wrap for end bracket to fix cables, 125mm Tie wrap for end bracket to fix cables, 150mm
	SYSTEM TIE WRAP	sb-DV060/W S-TW.EB060	Divider for fixing cables at end bracket System tie wrap to arrange for cables right after moving bracket or fixing bracket

Model	Classification	Part number	Description
ST120ERS	SIDE BAND	ST-SB120S(LH) ST-SB120S(RH)	Left side band of ST120E Right side band of ST120E
	BENDING RADIUS	ST-BR120.R180,200,250,300,350,400,500	Bending radius unit for side band
	SKID	ST-SK120RS(LH-N) ST-SK120RS(LH-R) ST-SK120RS(RH-N) ST-SK120RS(RH-R)	Skid for long travel(Applied to side band)
	SPRING	ST-SPR120 ST-SUP120	Supporter to fix skid unit
	SUPPORT	ST-SUP120	Spring with roller
	ROLLER	ST-RL120	Roller for long travel(Applied to side band)
	FRAME PIN	S-FP/S2	Frame pin
	FRAME(DOWN) FRAME(UP)	ST-FRD120,150 ST-FRU120,150 ST-FRD120,200 ST-FRU120,200 ST-FRD120,250 ST-FRU120,250 ST-FRD120,300 ST-FRU120,300	Inside frame, 150mm Outside frame, 150mm Inside frame, 200mm Outside frame, 200mm Inside frame, 250mm Outside frame, 250mm Inside frame, 300mm Outside frame, 300mm
	FRAME(DOWN-FIXING END) FRAME(UP-FIXING END) FRAME(DOWN-MOVING END) FRAME(UP-MOVING END)	ST-FRD120,150,200,250,300 ST-FRU120,150,200,250,300 ST-FRD120,150,200,250,300 ST-FRU120,150,200,250,300	Inside half-frame for fixing end bracket Outside half-frame for fixing end bracket Inside half-frame for moving end bracket Outside half-frame for moving end bracket
	FREE END BRACKET	ST-FEB120E sb-FEB/WH075	End bracket of ST120E Steel washer for end bracket
	DIVIDER	sb-DV075/M sb-DV075/S	Normal divider To fix separstors at the both side section
	SEPARATOR	sb-SP/400,400 SP-PIN075	Separator, 400mm Separator pin to fix
	TIE WRAP	S-TW50 S-TW75 S-TW100 S-TW125 S-TW150	Tie wrap for end bracket to fix cables, 50mm Tie wrap for end bracket to fix cables, 75mm Tie wrap for end bracket to fix cables, 100mm Tie wrap for end bracket to fix cables, 125mm Tie wrap for end bracket to fix cables, 150mm
	SYSTEM TIE WRAP	sb-DV075/W S-TW.EB075	Divider for fixing cables at end bracket System tie wrap to arrange for cables right after moving bracket or fixing bracket

# ST 044ERS

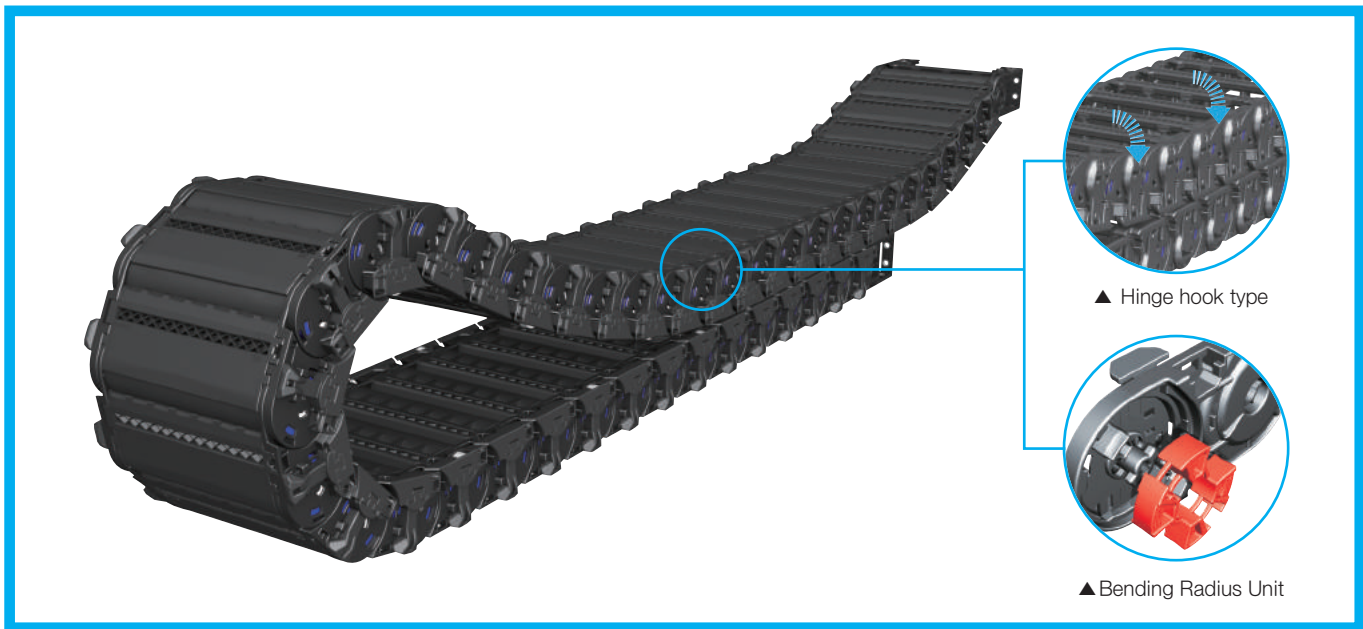

## Layout of the chain

Ls: Stroke

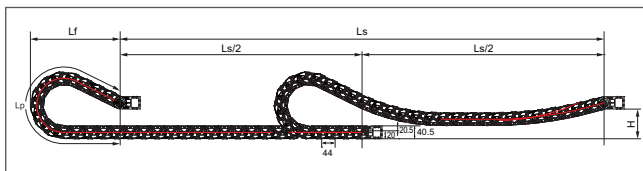

Bending Radius (R)	Lp Loop Length	Lf Loof Projection	H Moving Height
70	544	249	110
90	662	289	
120	926	393	
150	1,190	497	

(Dimensions in mm)

## Chain cross section

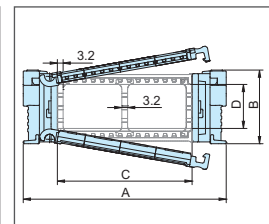
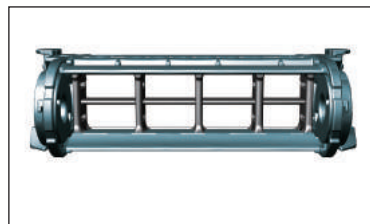

Chain Type	A Width(Outer)	B Height(Outer)	C Frame	D Height(Inner)	Weight kg/m
ST 044ERS	73	40.5	35	24.5	1.07
	93		55		1.16
	113		75		1.23
	138		100		1.33

(Dimensions in mm)

## Dividers(DV)

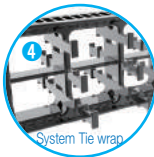
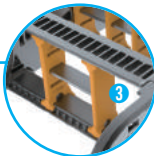
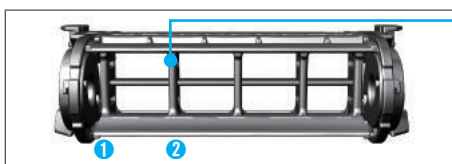

Assemble divider every second frame.  
 DV.M : Normal Divider.  
 DV.W : Applicable to System Tie Wrap or FEB.

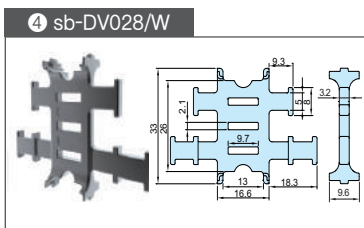
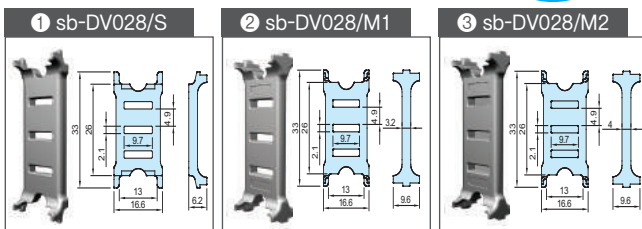

(Dimensions in mm)

## Separators(SP)

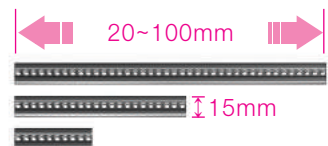
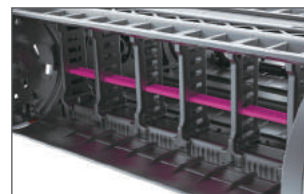

Chain Type	Ordering NO.	Frame
ST 044ERS	S-SP/M.35	35
	S-SP/M.55	55
	S-SP/M.75	75
	S-SP/M.100	100

(Dimensions in mm)



## Free end bracket

**Moving point**

**Fixing point**

Chain Type	A Width(Outer)	B Height(Outer)	C Frame	D Height(Inner)	E M,EB Bolt hole width	Hole Type
ST 044ERS	73	40.5	35	24.5	0.4	M5 Bolt Holes
	93		55		20.4	
	113		75		40.4	
	138		100		65.4	

(Dimensions in mm)

## System tie wrap (STW)

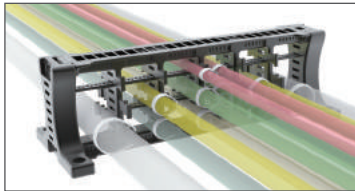

It is a unit to classify each cable for preventing entanglement of cables. It can either be installed to free end bracket or installed separately according to its application environment.

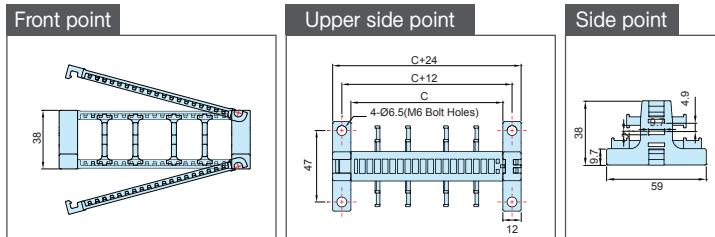

Chain Type	Ordering No.	C Frame	Hole Type
ST 044ERS	S-TW,EB028,35	35	M6 Bolt Holes
	S-TW,EB028,55	55	
	S-TW,EB028,75	75	
	S-TW,EB028,100	100	

(Dimensions in mm)

## Tie wrap (TW)

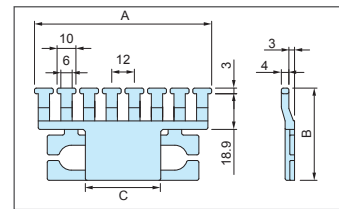
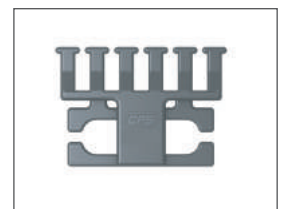
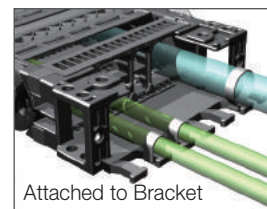

Chain Type	Ordering No.	A	B	
ST 044ERS	S-TW036/025CR,35	46	35.4	-
	S-TW036/025CR,55	70	48.9	20
	S-TW036/025CR,75	94	48.9	40
	S-TW036/025CR,100	118	48.9	65

(Dimensions in mm)

## Guide channel

**A - Zone**

**C - Zone**

**Housing (U-Shape)**

**Side Panel**

(Dimensions in mm)

# ST 072ERS

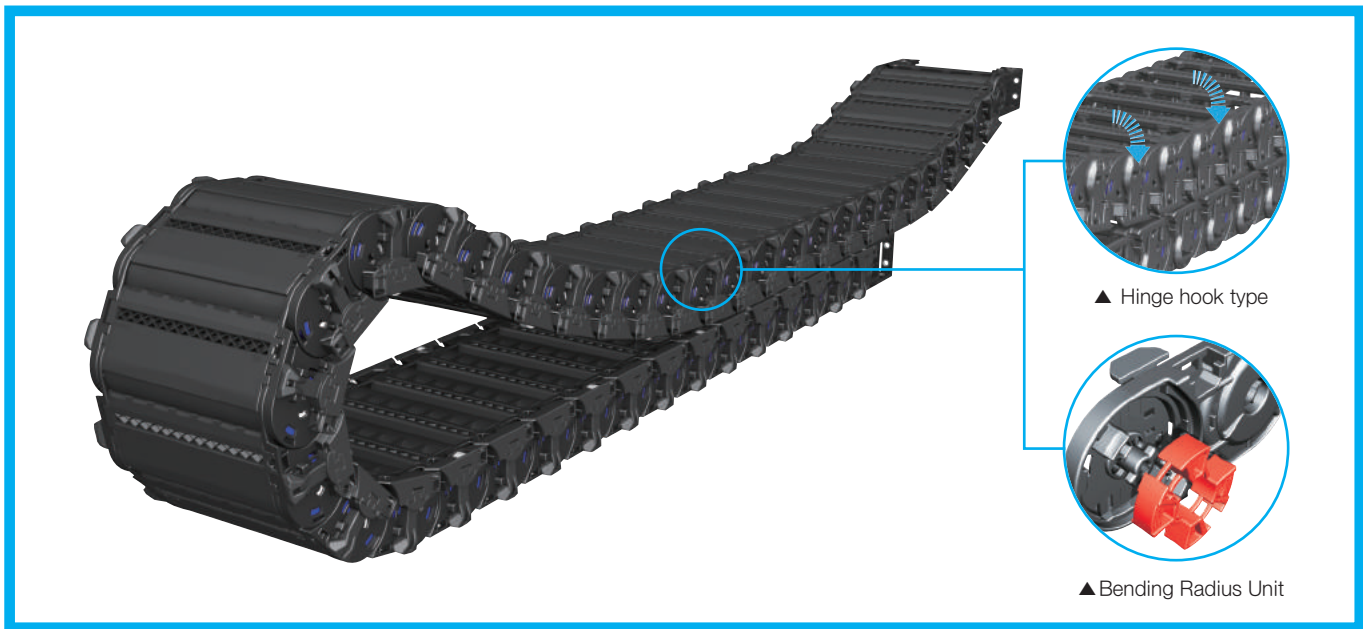

## Layout of the chain

Ls: Stroke

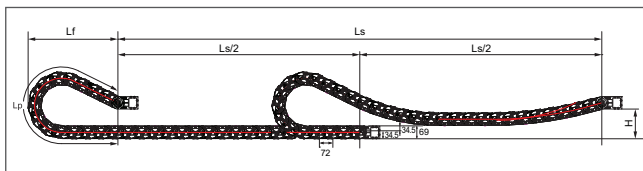

Bending Radius (R)	Lp Loop Length	Lf Loof Projection	H Moving Height
120	917	420	180
145	1,063	470	
200	1,400	580	
250	1,840	752	
300	2,280	924	

(Dimensions in mm)

## Chain cross section

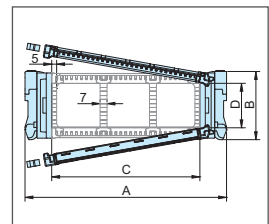
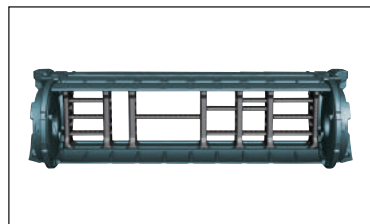

Chain Type	A Width(Outer)	B Height(Outer)	C Frame	D Height(Inner)	Weight kg/m
ST 072ERS	104	69	50	44	2.53
	129		75		2.65
	154		100		2.77
	179		125		2.89
	204		150		3.01

(Dimensions in mm)

## Dividers(DV)

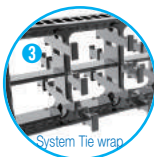
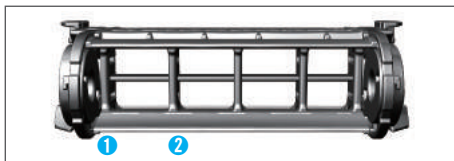

Assemble divider every second frame.  
 DV.M : Normal Divider.  
 DV.W : Applicable to System Tie Wrap or FEB.

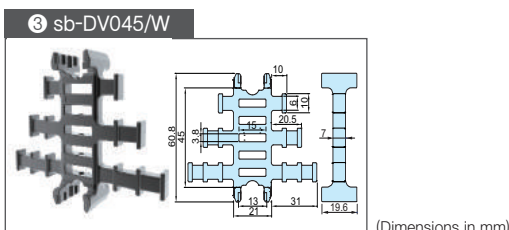
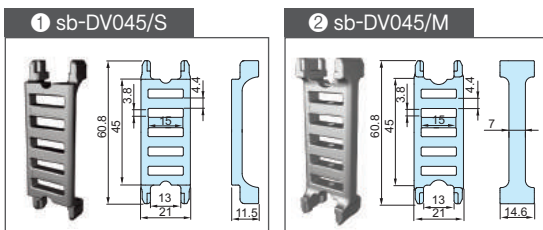

(Dimensions in mm)

## Separators(SP)

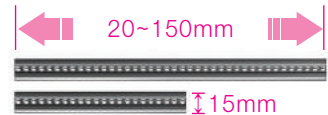
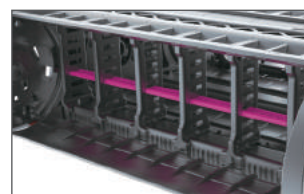

Chain Type	Ordering NO.
ST 072ERS	sb-SP/400,400

## Free end bracket

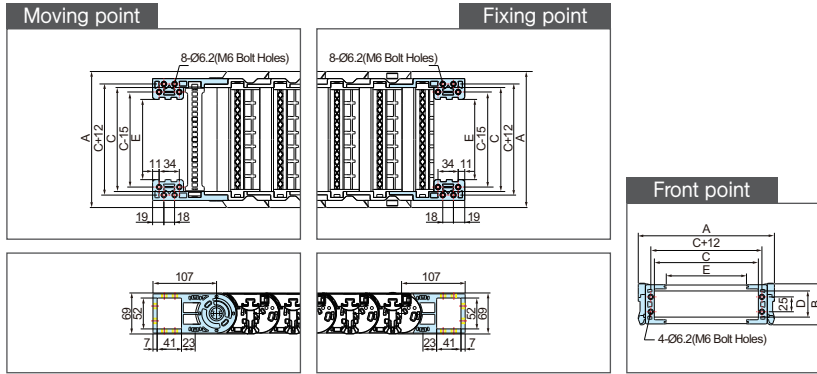

Chain Type	A Width(Outer)	B Height(Outer)	C Frame	D Height(Inner)	E M,EB Bolt hole width	Hole Type
ST 072ERS	104	69	50	44	10	M6 Bolt Holes
	129		75		35	
	154		100		60	
	179		125		85	
	204		150		110	

(Dimensions in mm)

## System tie wrap (STW)

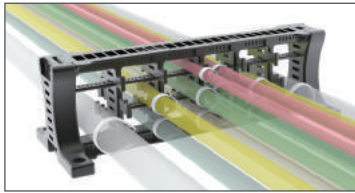

It is a unit to classify each cable for preventing entanglement of cables. It can either be installed to free end bracket or installed separately according its application environment.

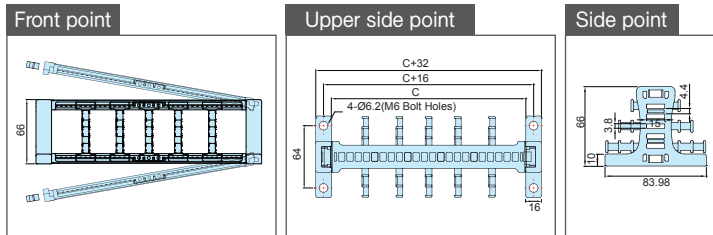

Chain Type	Ordering No.	C Frame	Hole Type
ST 072ERS	S-TW,EB045,50	50	M6 Bolt Holes
	S-TW,EB045,75	75	
	S-TW,EB045,100	100	
	S-TW,EB045,125	125	
	S-TW,EB045,150	150	

(Dimensions in mm)

## Tie wrap (TW)

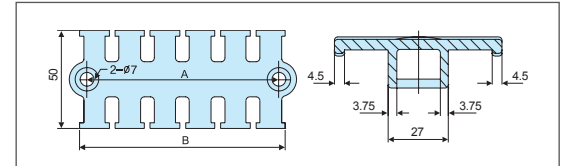
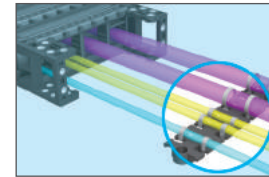

Chain Type	Ordering No.	A	B
ST 072ERS	S-TW50	58	65
	S-TW75	75	82
	S-TW100	98	105
	S-TW125	122	129
	S-TW150	141	148

(Dimensions in mm)

## Guide channel

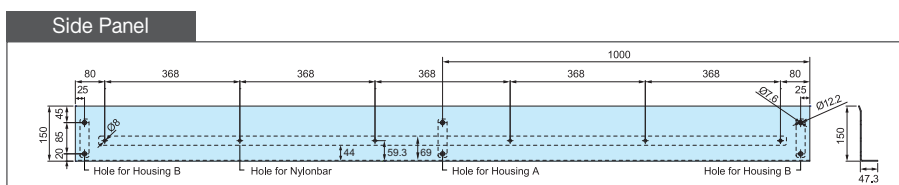
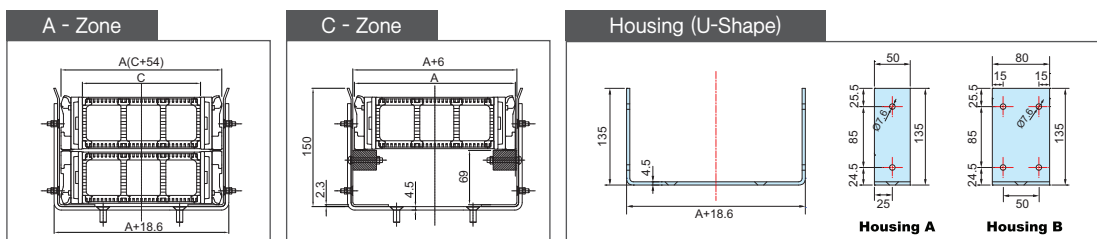

(Dimensions in mm)



# ST 095ERS

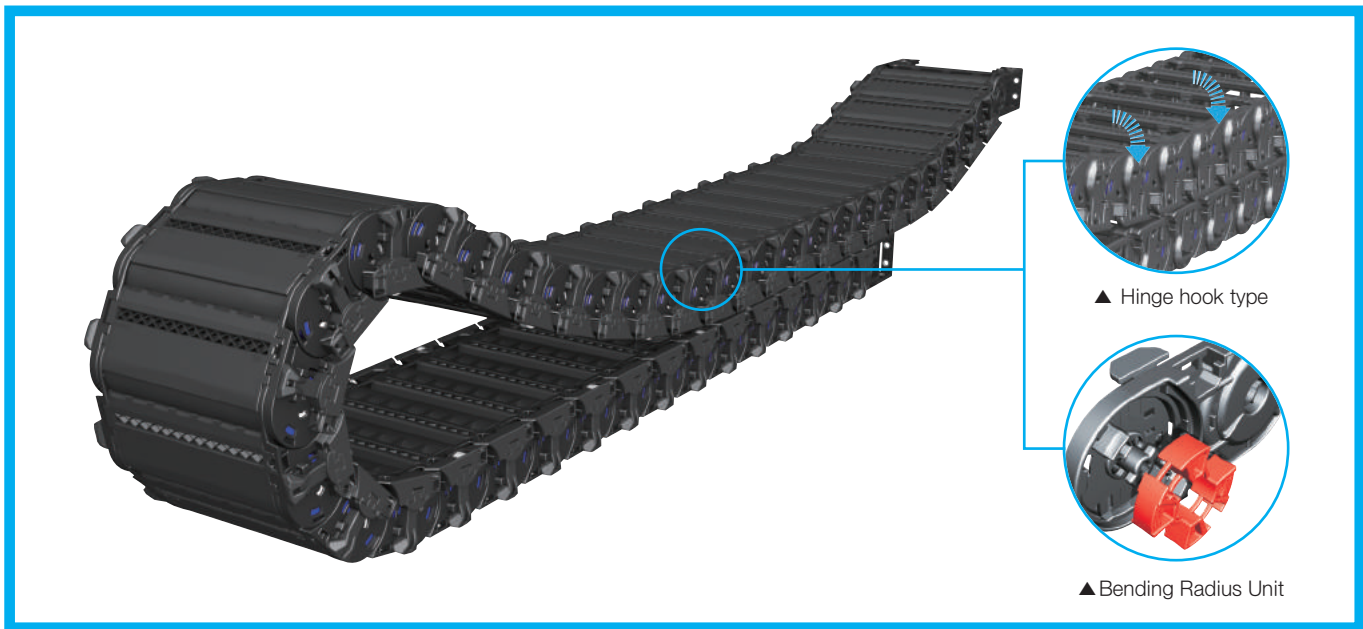

## Layout of the chain

Ls: Stroke

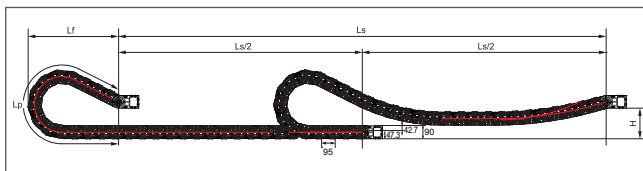

Bending Radius (R)	Lp Loop Length	Lf Loof Projection	H Moving Height
150	1,178	534	210
200	1,479	634	
230	1,666	694	
280	2,146	889	
400	3,232	1,319	

(Dimensions in mm)

## Chain cross section

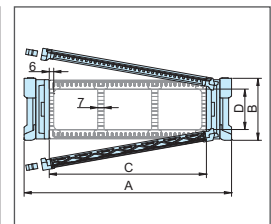
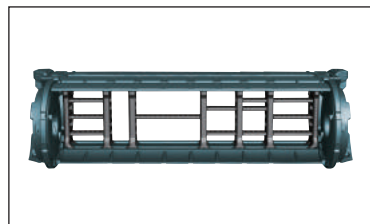

Chain Type	A Width(Outer)	B Height(Outer)	C Frame	D Height(Inner)	Weight kg/m
ST 095ERS	168	90	100	55	4.20
	193		125		4.45
	218		150		4.70
	243		175		4.95
	268		200		5.19

(Dimensions in mm)

## Dividers(DV)

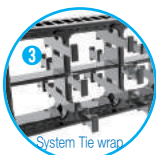
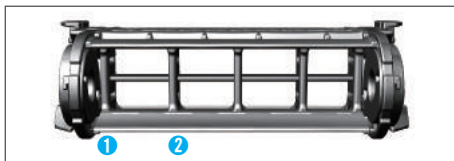

Assemble divider every second frame.  
 DV.M : Normal Divider.  
 DV.W : Applicable to System Tie Wrap or FEB.

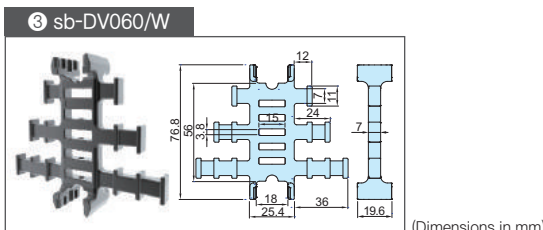
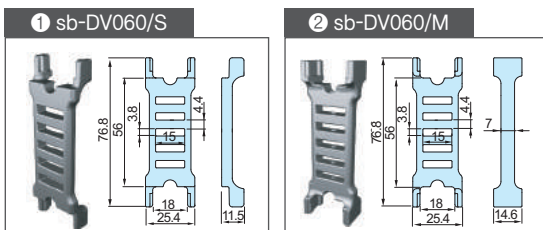

(Dimensions in mm)

## Separators(SP)

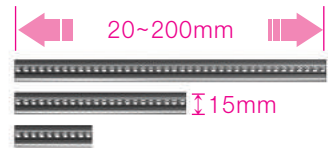
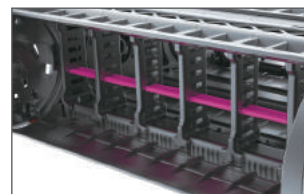

Chain Type	Ordering NO.
ST 095ERS	sb-SP/400,400

## Free end bracket

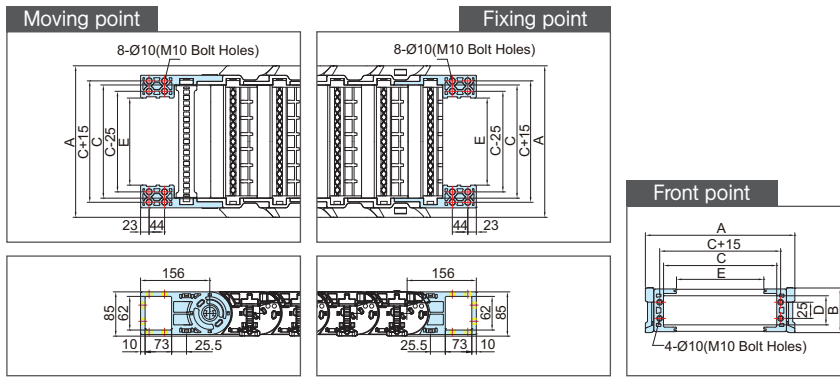

Chain Type	A Width(Outer)	B Height(Outer)	C Frame	D Height(Inner)	E M,EB Bolt hole width	Hole Type
ST 095ERS	168	90	100	55	49	M10 Bolt Holes
	193		125		74	
	218		150		99	
	243		175		124	
	268		200		149	

(Dimensions in mm)

## System tie wrap (STW)

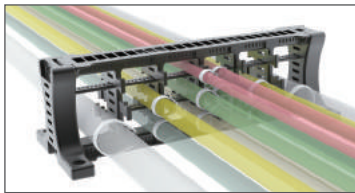

It is a unit to classify each cable for preventing entanglement of cables. It can either be installed to free end bracket or installed separately according its application environment.

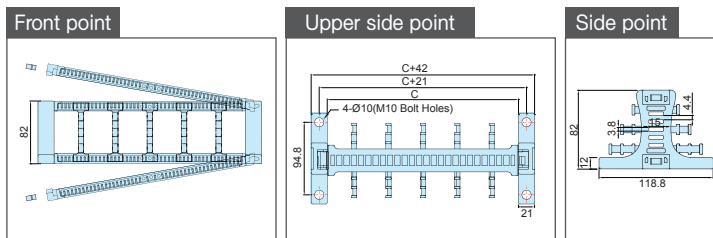

Chain Type	Ordering No.	C Frame	Hole Type
ST 095ERS	S-TW,EB060,100	100	M10 Bolt Holes
	S-TW,EB060,125	125	
	S-TW,EB060,150	150	
	S-TW,EB060,175	175	
	S-TW,EB060,200	200	

(Dimensions in mm)

## Tie wrap (TW)

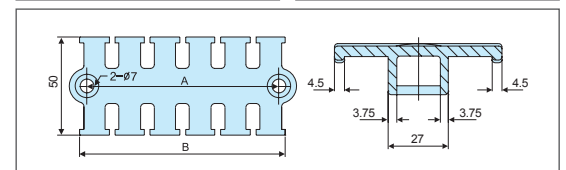
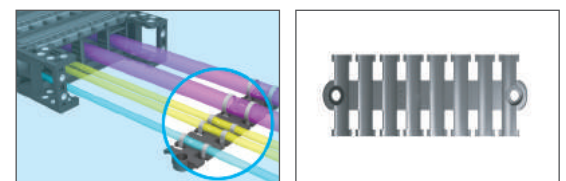

Chain Type	Ordering No.	A	B
ST 095ERS	S-TW50	58	65
	S-TW75	75	82
	S-TW100	98	105
	S-TW125	122	129
	S-TW150	141	148

(Dimensions in mm)

## Guide channel

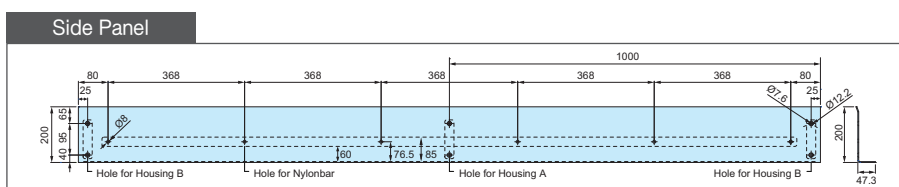
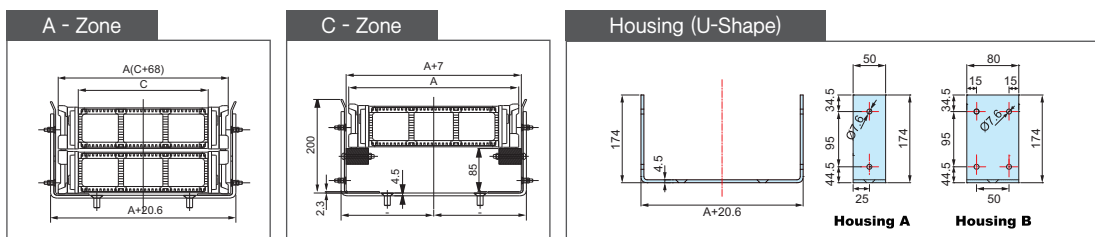

(Dimensions in mm)

# ST 120ERS

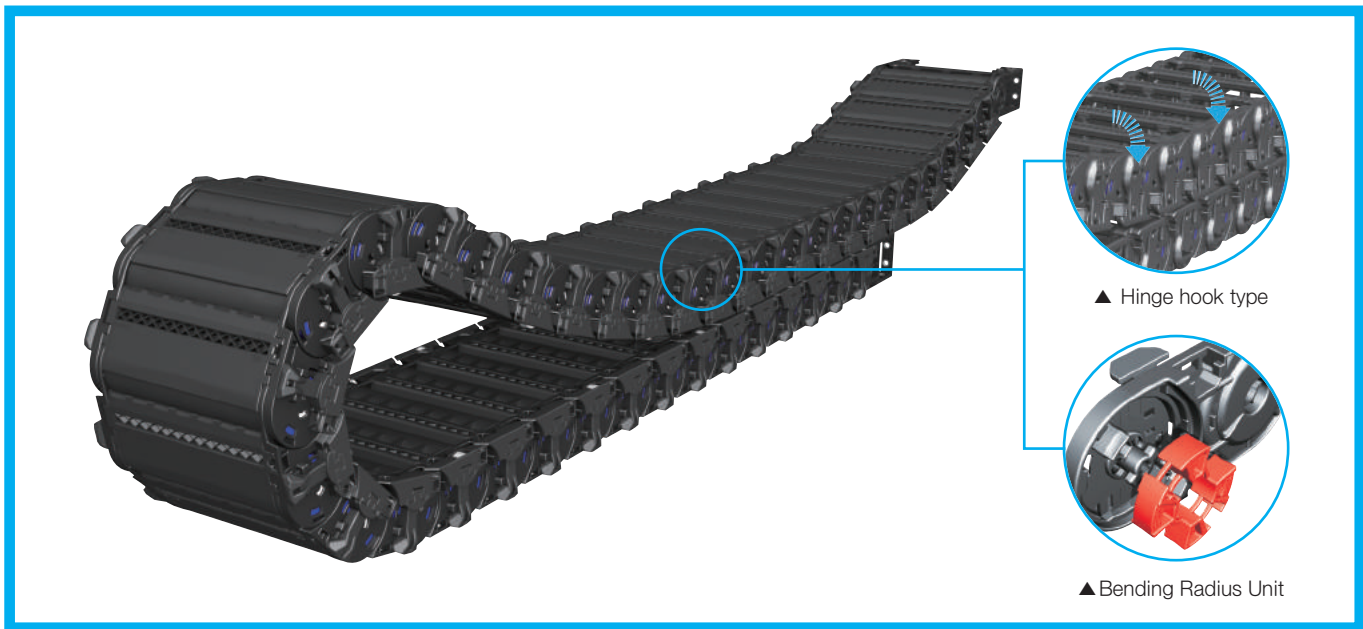

## Layout of the chain

Ls: Stroke

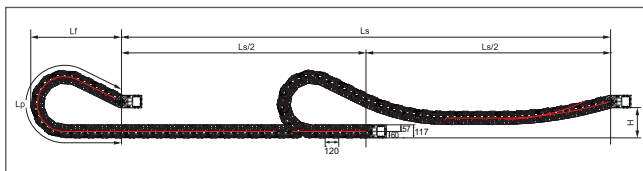

Bending Radius (R)	Lp Loop Length	Lf Loof Projection	H Moving Height
200	1,559	694	260
250	1,864	794	
300	2,178	894	
350	2,701	1,114	
400	3,225	1,334	
500	4,062	1,654	

(Dimensions in mm)

## Chain cross section

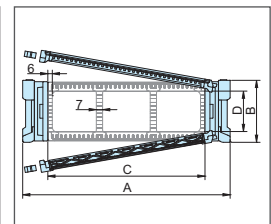
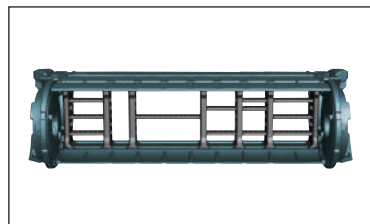

Chain Type	A Width(Outer)	B Height(Outer)	C Frame	D Height(Inner)	Weight kg/m
ST 120ERS	218	117	150	76	5.17
	268		200		5.48
	318		250		5.78
	368		300		6.09

(Dimensions in mm)

## Dividers(DV)

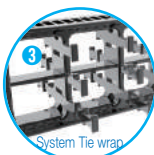
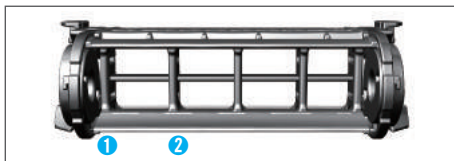

Assemble divider every second frame.  
 DV.M : Normal Divider.  
 DV.W : Applicable to System Tie Wrap or FEB.

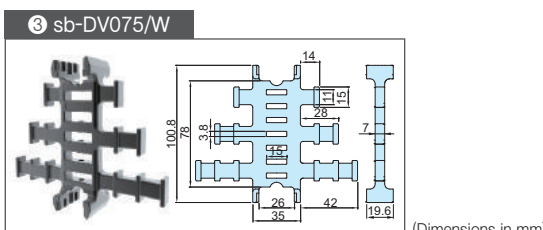
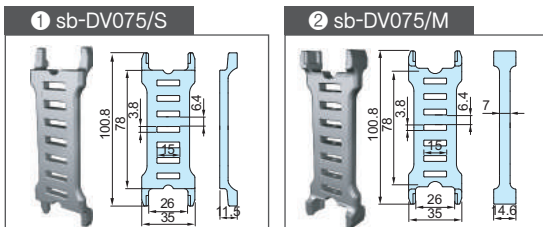

(Dimensions in mm)

## Separators(SP)

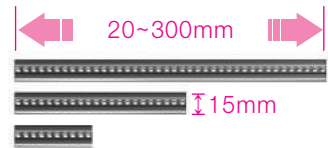
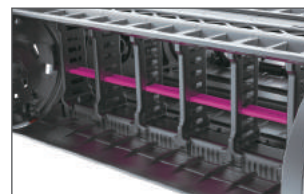

Chain Type	Ordering NO.
ST 120ERS	sb-SP/400,400



## Free end bracket

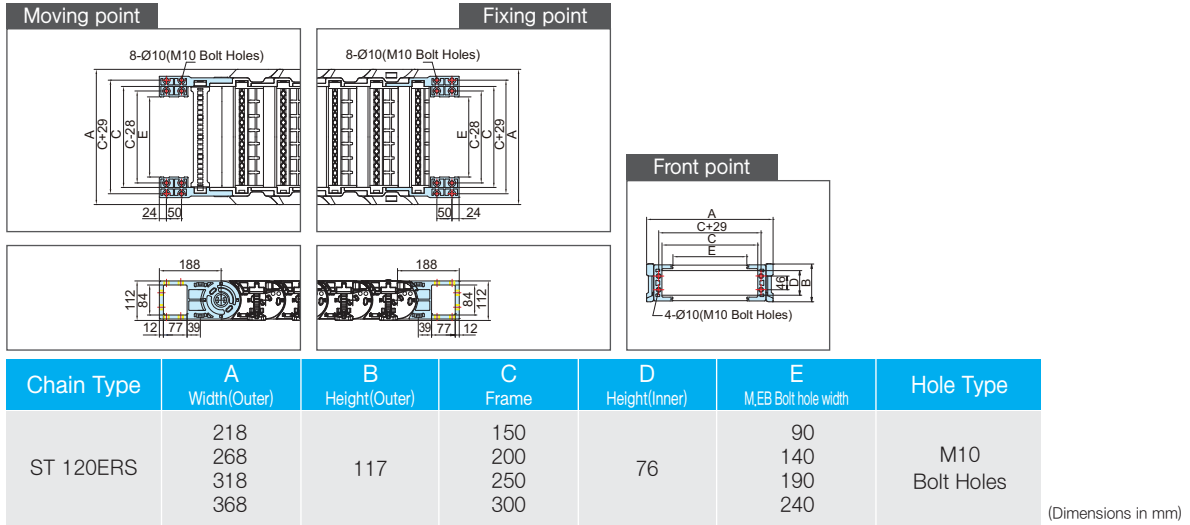

## System tie wrap (STW)

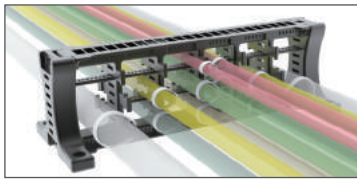

It is a unit to classify each cable for preventing entanglement of cables. It can either be installed to free end bracket or installed separately according its application environment.

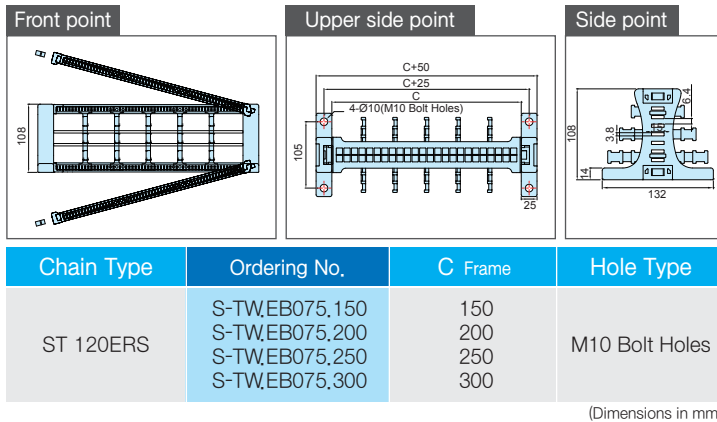

## Tie wrap (TW)

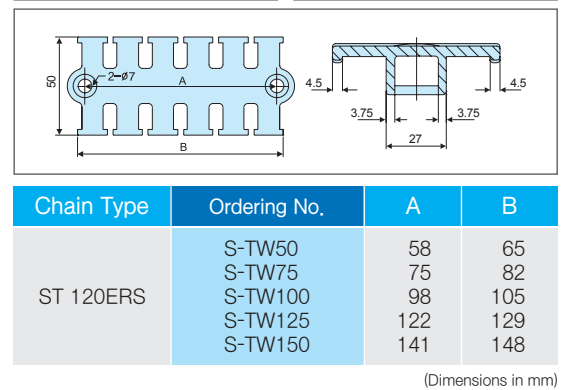
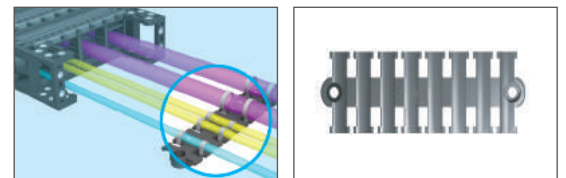

## Guide channel

