

DATENBLATT / DATA SHEET	Seite 1 von 2
Motor-Drossel 15Z1F04-1010	Rev. D



ALLGEMEINE BESCHREIBUNG / GENERAL DESCRIPTION

Filtertyp	<i>type of filter</i>	Motor-Drossel / motor choke
Leiteranzahl	<i>number of phases</i>	3 Ph. + PE / ground
Anschlussquerschnitt / Klemme Anzugmoment	<i>conductor cross section / terminal torque</i>	10,0mm ² 2,0 Nm / 17.7 lb-inch
Anschlussquerschnitt PE Anzugmoment	<i>conductor cross section PE torque</i>	M4 3,3 Nm / 29.2 lb-inch
Approbation	<i>approvals</i>	CE, cURus (UL-file: E312146)

ELEKTRISCHE DATEN AUSGANGS - DROSSEL / ELECTRICAL DATA OUTPUT - CHOKE

Bemessungsspannung <i>nominal voltage</i>	[V _{AC}]	3 x 400 (max. 530)
Bemessungsstrom / Nennstrom <i>nominal current (I_N at T_{max})</i>	[A]	24
Max. Strom <i>max. current (t_{max} ≤ 30sec)</i>	[A]	36
Max. Motor-Frequenz <i>max. motor-frequency</i>	[Hz]	100
Induktivität <i>rated inductance</i>	[mH]	0,5
Max. Umgebungstemperaturen <i>max. ambient temperatures</i>	[°C]	-10...45
Spannungsabfall bei I _N <i>voltage loss at I_N, 50Hz</i>	[%]	4
DC-Widerstand <i>DC-resistance</i>	[mΩ]	14,2
Verlustleistung <i>power dissipation (at I_N, f_N)</i>	[W]	47
Schutzklasse <i>protection class</i>		IP20
Klimakategorie <i>Category for climate (as EN60721-3-3)</i>		3K3

Erstellt:	Breitenbach	Geprüft:	Erasmie	Freigegeben:	Breitenbach
Datum:	23.02.2015	Datum:	23.02.2015	Datum:	05.04.2012

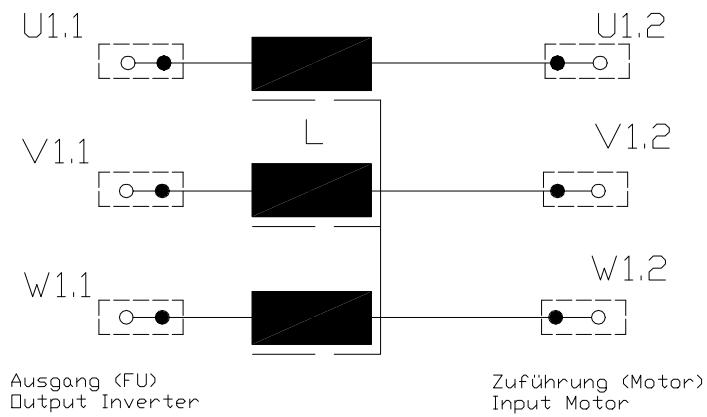
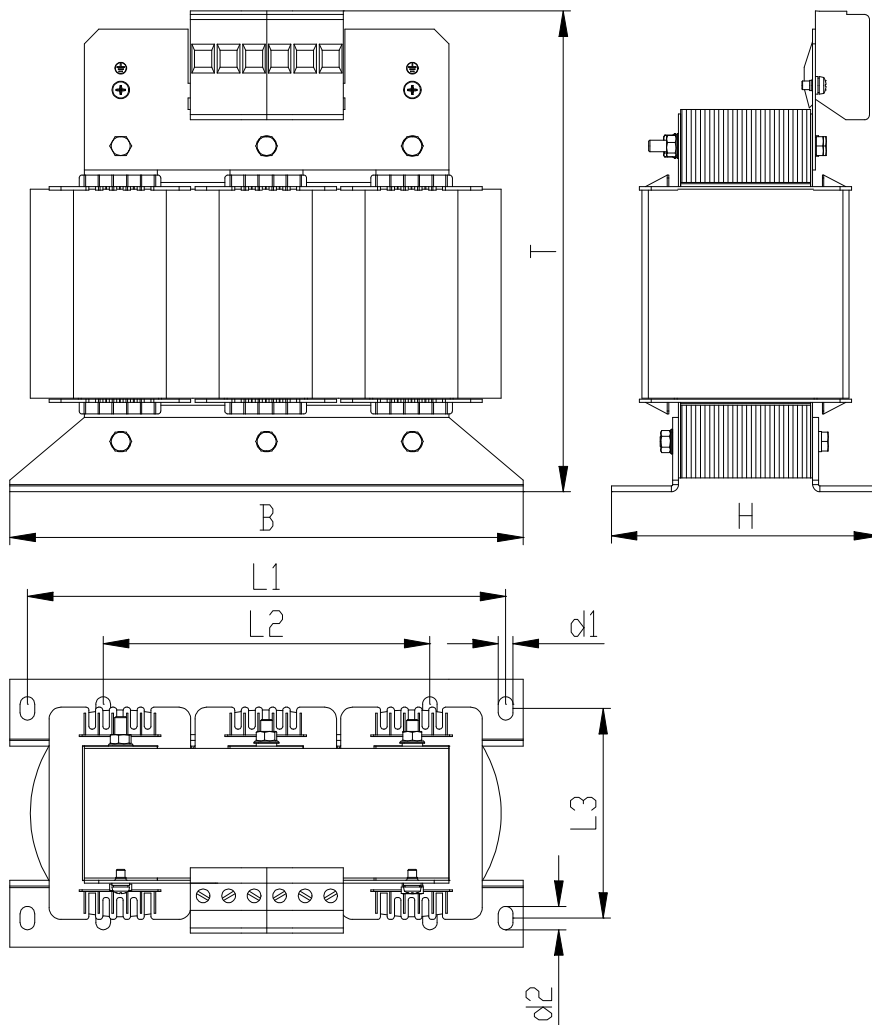
SCHALTBILD / CIRCUIT DIAGRAM**MECHANISCHER AUFBAU / MECHANICAL OUTLINE**

Maß B in mm	Maß H in mm	Maß T in mm	Maß L1 in mm	Maß L2 in mm	Maß L3 in mm	Maß d1 in mm	Maß d2 in mm	Gewicht in kg	CU in kg
178	72	178	166	113	53	4,8	8	3,9	1,25