

DATENBLATT / DATA SHEET	Seite 1 von 2
<b>Motor-Drossel 18Z1F04-1010</b>	Rev. D



### ALLGEMEINE BESCHREIBUNG / GENERAL DESCRIPTION

Filtertyp	<i>type of filter</i>	<b>Motor-Drossel / motor choke</b>
Leiteranzahl	<i>number of phases</i>	3 Ph. + PE / ground
Anschlussquerschnitt / Klemme Anzugmoment	<i>conductor cross section / terminal torque</i>	35,0mm <sup>2</sup> 5,0 Nm / 44.25 lb-inch
Anschlussquerschnitt PE Anzugmoment	<i>conductor cross section PE torque</i>	M6 6,0 Nm / 53.1 lb-inch
Approbation	<i>approvals</i>	CE, cURus (UL-file: E312146)

### ELEKTRISCHE DATEN AUSGANGS - FILTER / ELECTRICAL DATA OUTPUT - FILTER

Bemessungsspannung <i>nominal voltage</i>	[V <sub>AC</sub> ]	3 x 400 (max. 530)
Bemessungsstrom / Nennstrom <i>nominal current (I<sub>N</sub> at T<sub>max</sub>)</i>	[A]	50
Max. Strom <i>max. current (t<sub>max</sub> ≤ 30sec)</i>	[A]	75
Max. Motor-Frequenz <i>max. motor-frequency</i>	[Hz]	100
Induktivität <i>rated inductance</i>	[mH]	0,24
Max. Umgebungstemperaturen <i>max. ambient temperatures</i>	[°C]	-10...45
Spannungsabfall bei I <sub>N</sub> <i>voltage loss at I<sub>N</sub>, 50Hz</i>	[%]	4
DC-Widerstand <i>DC-resistance</i>	[mΩ]	4,4
Verlustleistung <i>power dissipation (at I<sub>N</sub>, f<sub>N</sub>)</i>	[W]	65
Schutzklasse <i>protection class</i>		IP20
Klimakategorie <i>Category for climate (as EN60721-3-3)</i>		3K3

Erstellt:	Breitenbach	Geprüft:	Erasmie	Freigegeben:	Breitenbach
Datum:	24.02.2015	Datum:	24.02.2015	Datum:	15.02.2012

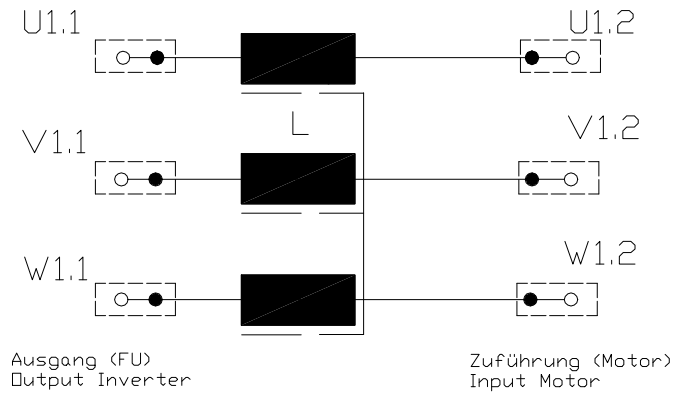
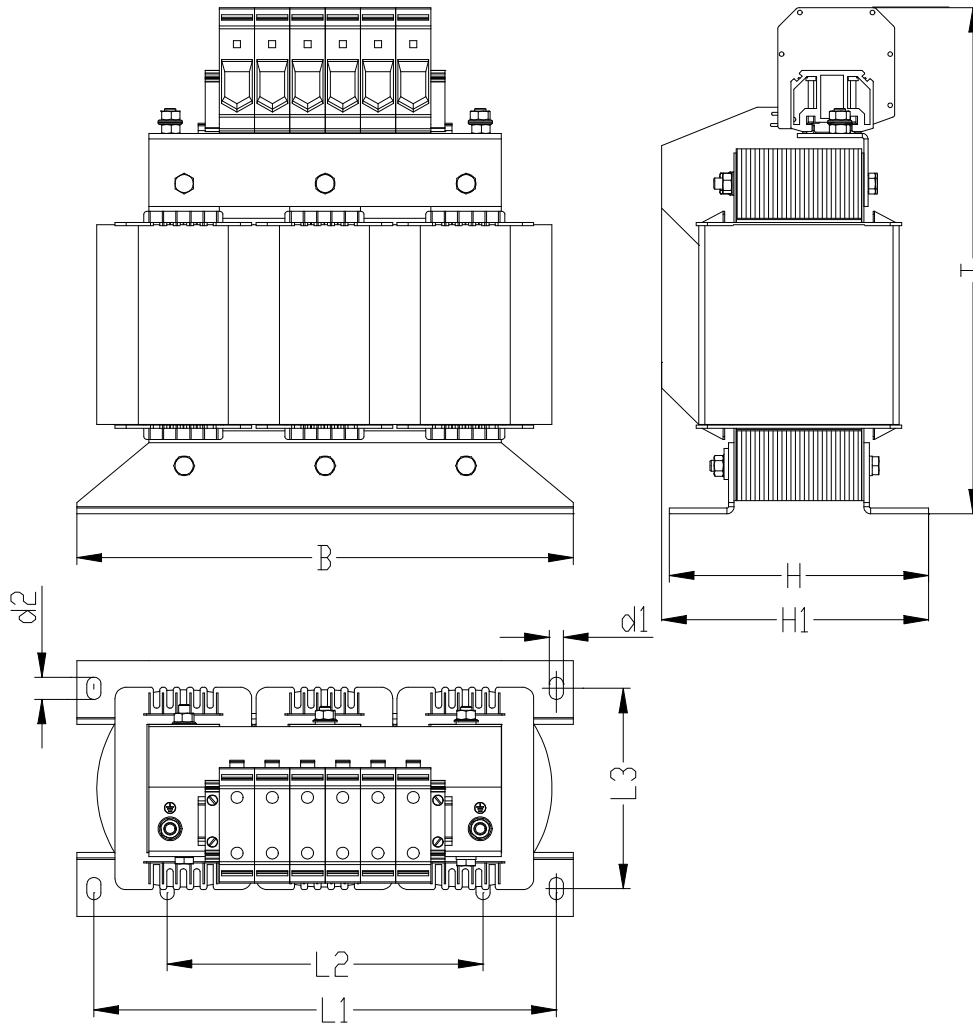
**SCHALTBILD / CIRCUIT DIAGRAM****MECHANISCHER AUFBAU / MECHANICAL OUTLINE**

Maß B in mm	Maß H in mm	Maß H1 in mm	Maß T in mm	Maß L1 in mm	Maß L2 in mm	Maß L3 in mm	Maß d1 in mm	Maß d2 in mm	Gewicht in kg	CU in kg
219	110	110	220	201	136	81	7	12	8,5	2,4