

DATENBLATT / DATA SHEET	Seite 1 von 2
Motor-Drossel 30Z1F04-1010	Rev. A



ALLGEMEINE BESCHREIBUNG / GENERAL DESCRIPTION

Filtertyp	<i>type of filter</i>	Motor-Drossel / motor choke
Leiteranzahl	<i>number of phases</i>	3 Ph. + PE / <i>ground</i>
Anschlussquerschnitt / Klemme Anzugmoment	<i>conductor cross section / terminal torque</i>	M12 (185,0mm ²) 56 Nm / 495.6 lb-inch
Anschlussquerschnitt PE Anzugmoment	<i>conductor cross section PE torque</i>	M8 16 Nm / 141.6 lb-inch
Approbation	<i>approvals</i>	CE, cURus (UL-file: E312146)

ELEKTRISCHE DATEN AUSGANGS - FILTER / ELECTRICAL DATA OUTPUT - FILTER

Bemessungsspannung <i>nominal voltage</i>	[V _{AC}]	3 x 400 (max. 530)
Bemessungsstrom / Nennstrom <i>nominal current (I_N at T_{max})</i>	[A]	570
Max. Strom <i>max. current (t_{max} ≤ 30sec)</i>	[A]	713
Max. Motor-Frequenz <i>max. motor-frequency</i>	[Hz]	100
Induktivität <i>rated inductance</i>	[μH]	21
Max. Umgebungstemperaturen <i>max. ambient temperatures</i>	[°C]	-10...45
Spannungsabfall bei I _N <i>voltage loss at I_N, 50Hz</i>	[%]	4
DC-Widerstand <i>DC-resistance</i>	[mΩ]	0,209
Verlustleistung <i>power dissipation (at I_N, f_N)</i>	[W]	650
Schutzklasse <i>protection class</i>		IP00
Klimakategorie <i>Category for climate (as EN60721-3-3)</i>		3K3

Erstellt:	Breitenbach	Geprüft:	Erasmie	Freigegeben:	
Datum:	24.02.2015	Datum:	24.02.2015	Datum:	

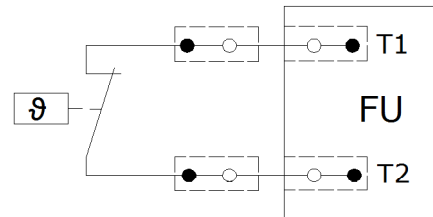
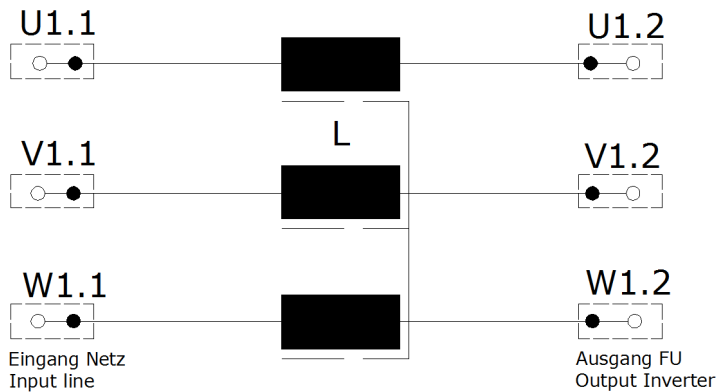
SCHALTBILD / CIRCUIT DIAGRAM

Der TempSchalter (Öffner) kann auch, falls benötigt, zur Temperatur-Erfassung des Motors in Reihe geschaltet werden.
The temperature contact (opener) also may be connected in series with the temperature-acquisition of the motor, if required.

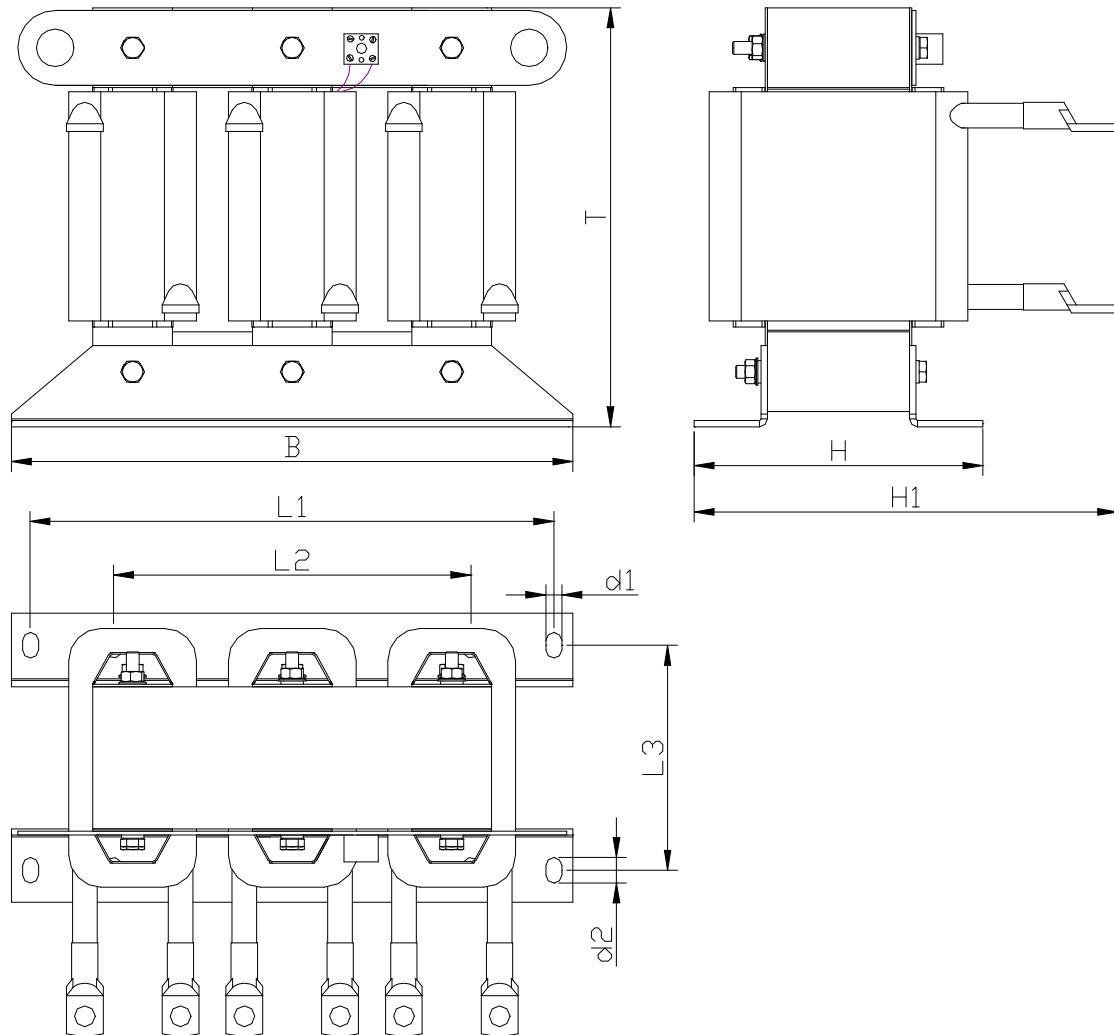
MECHANISCHER AUFBAU / MECHANICAL OUTLINE

Maß B in mm	Maß H in mm	Maß H1 in mm	Maß T in mm	Maß L1 in mm	Maß L2 in mm	Maß L3 in mm	Maß d1 in mm	Maß d2 in mm	Gewicht in kg	CU in kg
412	167	257	325	388	264	128	10	16	ca. 52	11,5