

## IS620 Series - Single Axis Servo

For general purpose applications

**EtherCAT**  **CANopen**

**Pulse/analog input**  
**Embedded motion**



# IS620 series servos

High-performance servo system for motion control applications



## IS620 series servo drive - key features

### High performance

- Current loop bandwidth > 4 kHz
- Speed loop bandwidth: 1.2 kHz

### Wide range

- Supply voltage
  - Single-phase 220 V
  - Three-phase 220 V
  - Three-phase 380 V

- 0.1 kW to 7.5 kW

### Network compatibility

- Pulse/analog – IS620P series servo
- EtherCAT – IS620N series servo
- CANopen – IS620P-CO series servo

### Easy-to-use

- Easy commissioning with keypad
- Fine tuning with PC software (InoServoShop)

### Smart tuning

- Inertia auto-tuning (on-line/off-line)
- Automatic gain tuning
- Adaptive notch filter
- Automatic/manual damping filter for low frequency resonance

## MS1 series servo motor - key features

### High precision

- 23-bit resolution multi-turn absolute encoder

### Reliable operation

- IP67 rating (shaft opening fulfills IP65 rating with oil seal option)
- Low cogging torque – 1% of rated torque

### Wide selection

- Motor frame – 40, 60, 80, 100, 130, 180
- Rated torques from 0.16 Nm to 48.0 Nm
- Low and medium inertia selection
- Rated speed 1,500 rpm or 3,000 rpm

### Powerful performance

- Rated torque 350% (750 W or less MS1 motor)

# IS620 series highlights

The IS620 series is engineered to achieve the highest possible performance and reliability – enabling users to maximize the productivity of their automation systems

## High accuracy - multi-turn absolute encoder with 23 bit resolution

Proprietary Inovance algorithm

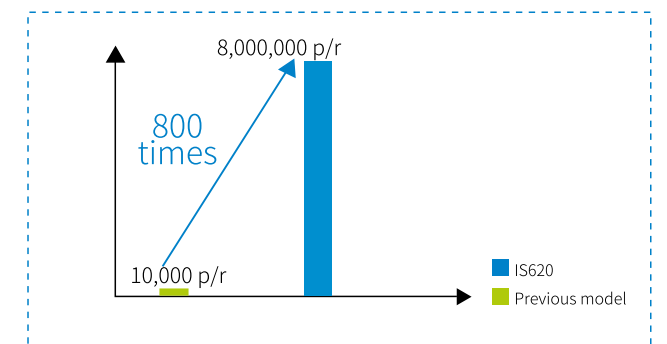
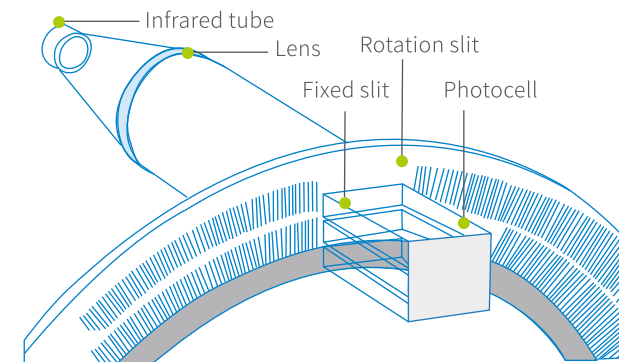

The 23-bit multi-turn absolute encoder, developed by WeTon, an Inovance subsidiary, has a resolution of 8 million pulses per revolution for extremely precise positioning applications such as industrial robots, machine tools and semiconductor manufacturing machinery.

The system's battery ensures data is backed-up at servo drive power-off and calculates the mechanical absolute position after servo drive power-on. It does not need to repeat the homing operation.

## Smaller footprint, higher performance

The built-in encoder has been developed in-house and is designed to achieve the smallest possible footprint, so the flange is kept the same all along the motor. The MS1H1 and MS1H4 motors are suitable for equipment requiring high torque (maximum torque of 350%).

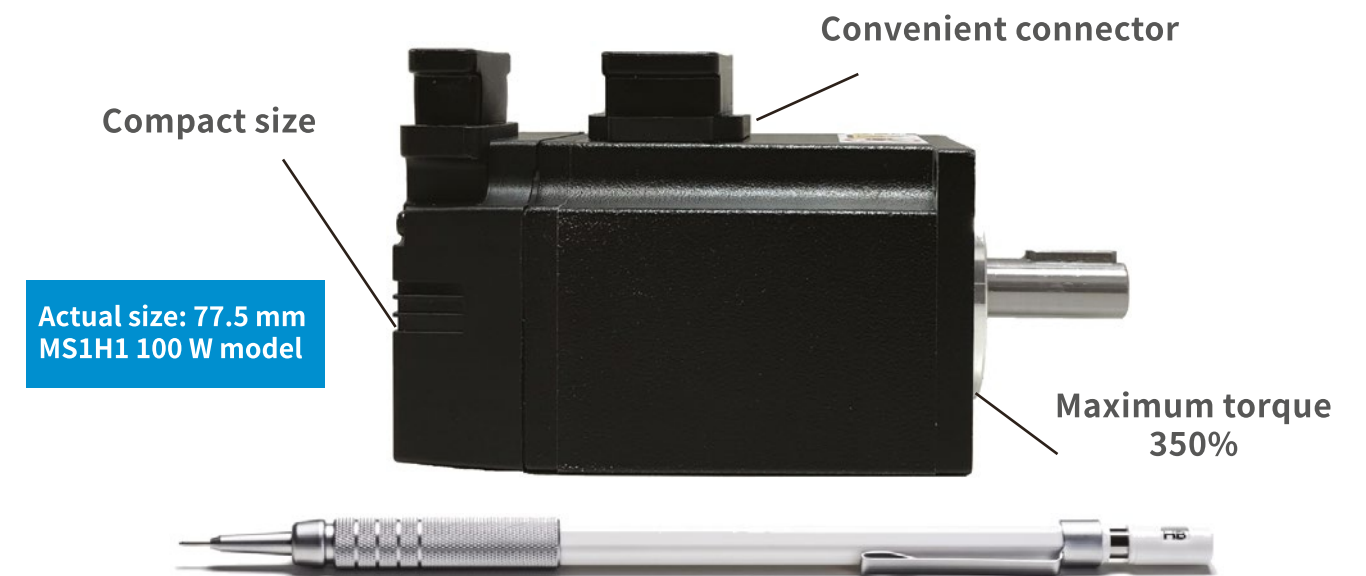

# IS620 series highlights

Engineered for performance and reliability in a compact footprint

## Improved performance – speed loop bandwidth 1.2 kHz

Speed loop bandwidth is a measure of how fast the motor can respond. High response control based on torque feed forward can reduce the settling time of machines. The settling time of IS620's position control is only 5.0-6.0 ms.

- Shorter settling time
- Reduced positioning time
- Higher throughput

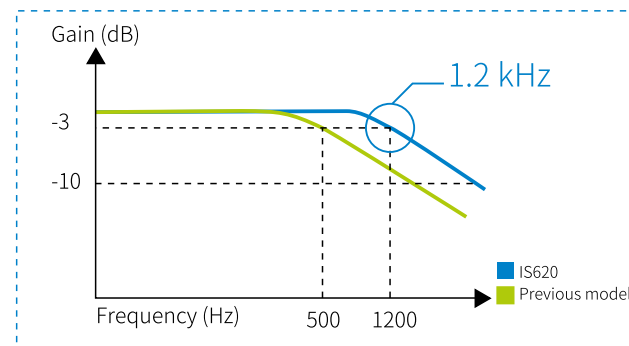

## Smart tuning – easy commissioning with new tuning function

The machine can be automatically optimized using the automatic gain tuning function based on the stiffness level to achieve fast response and stability.

- **Load inertia identification:** on-line and off-line inertia identification
- **Automatic gain adjustment:** speed and position loop gains can be automatically adjusted by setting the stiffness level
- **Self-adaptive notch filter:** The vibration frequency can be automatically detected and the notch filter can be automatically set
- **Damping filter:** suppresses vibration from 1 to 100 Hz

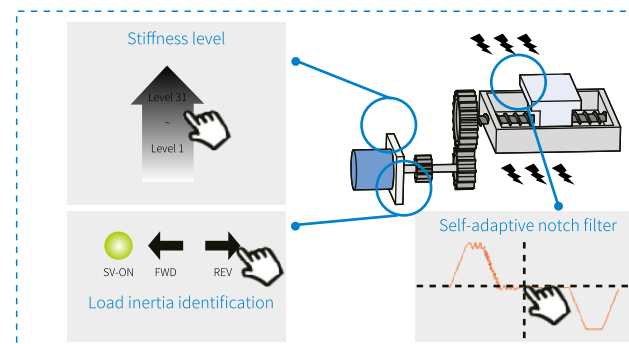

## Wide protocol – pulse/analog, EtherCAT, MODBUS, CANopen

The IS620 family of servo drives support a variety of protocols for your system.

- IS620P servo drive
  - Pulse/analog input;
  - MODBUS RTU: RS232/RS485
  - Internal positioning: up to 16 positions can be stored
  - Supports point-to-point positioning using a simple digital input from the controller
- IS620N servo drive
  - EtherCAT: complies with CiA 402 drive profile
- IS620P-CO servo drive
  - CANopen: device profile specification for embedded systems

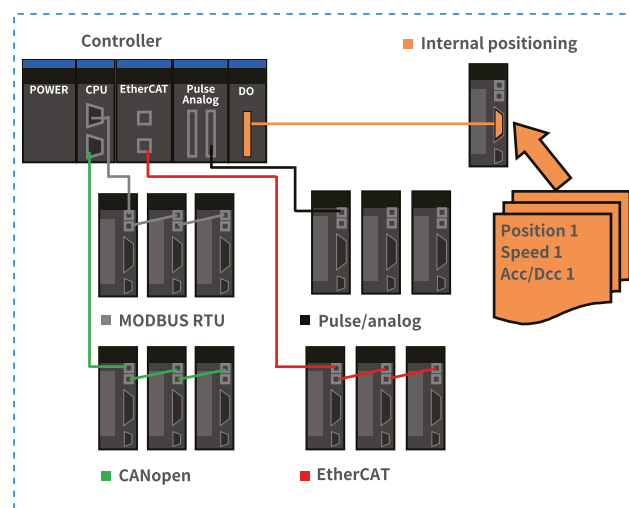

# IS620 servo drive technical data

Servo drive for position, speed, and torque control via pulse/analog, EtherCAT

## IS620 P S 5R5 I - A - INT

① Series IS620 servo drive	④ Rated output current 1R6: 1.6 A ... 021: 21 A 026: 26 A	⑥ Customized function A: 16-bit analog input C: CANlink CO: CANopen
② Product type P: pulse/analog N: EtherCAT	⑤ Installation I: base mount	⑦ Version INT: international
③ Voltage class S: 220 Vac T: 400 Vac		

## Servo drive specifications

Single-phase 220 V

Frame size	SIZE-A		
Model no.	S1R6	S2R8	S5R5
Rated current (A)	1.6	2.8	5.5
Maximum current (A)	5.8	10.1	16.9
Input voltage	Single-phase 200 to 240 Vac, +10 to -15%, 50/60 Hz		
Internal DBR	No	50Ω / 50 W	

Three-phase 220 V

SIZE-A	SIZE-C	
S5R5	S7R6	S012
5.5	7.6	11.6
16.9	17	28
Three-phase 200 to 240 Vac, +10 to -15%, 50/60 Hz		
50Ω / 50 W	25Ω / 80 W	

Three-phase 380 V

Frame size	SIZE-C				SIZE-E		
Model no.	T3R5	T5R4	T8R4	T012	T017	T021	T026
Rated current (A)	3.5	5.4	8.4	11.9	16.5	20.8	25.7
Maximum current (A)	8.5	14.0	20.0	24.0	42.0	55.0	65.0
Input voltage	Three-phase 380 to 440 Vac, +10 to -15%, 50/60 Hz						
Internal DBR	100Ω / 80 W		50Ω / 80 W		40Ω / 100 W		

Notes: internal DBR is built-in regenerative resistor specification

Models S1R6 and S2R8 are not configured with a built-in regenerative resistor. Use an external regenerative resistor if necessary

## Servo drive dimensions

Size	L (mm)	H (mm)	D (mm)	L1 (mm)	H1 (mm)	D1 (mm)	Screw hole	Tightening torque (Nm)
A	50	160	173	40	150	75	2-M4	0.6 to 1.2
C	90	160	184	80	150	75	4-M4	0.6 to 1.2
E	100	250	230	90	240	75	4-M4	0.6 to 1.2

# IS620P servo drive configuration

Wiring example for single-phase 220 V system

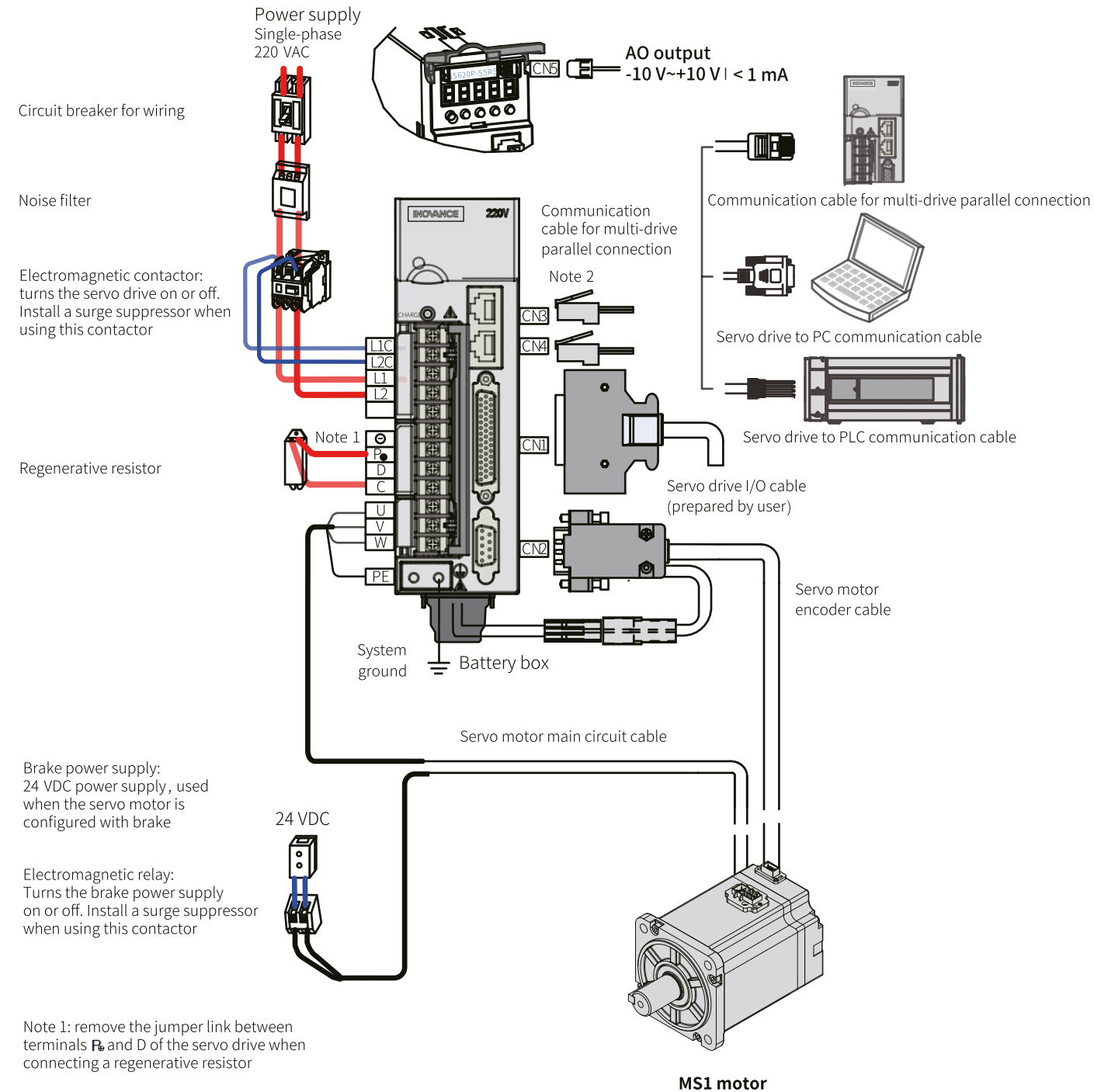

Pulse/analog

# IS620P servo drive configuration

Wiring example for three-phase 220 V/380 V system

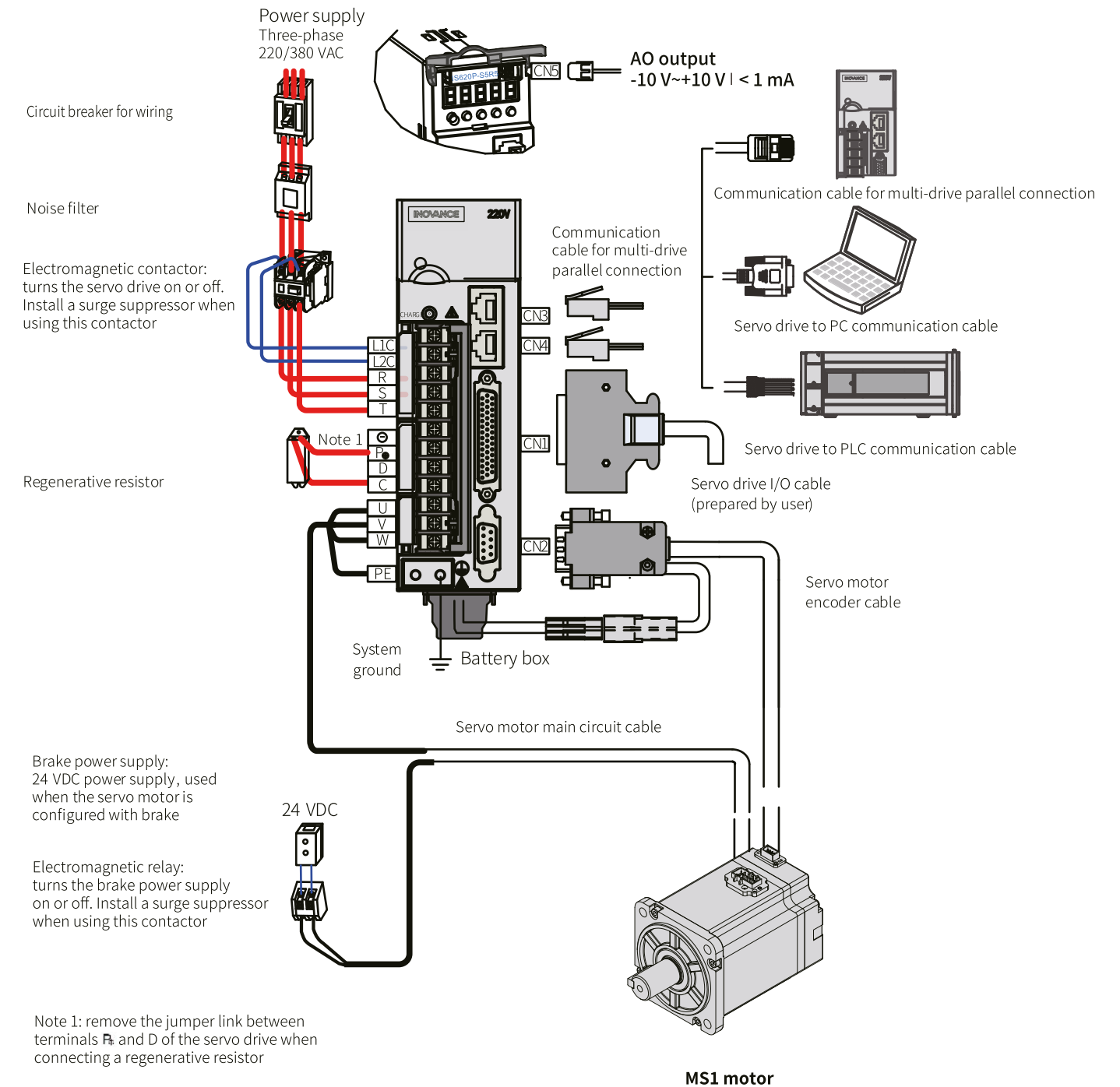

Pulse/analog

# IS620P servo drive connection diagram

Standard wiring for pulse train input, analog input

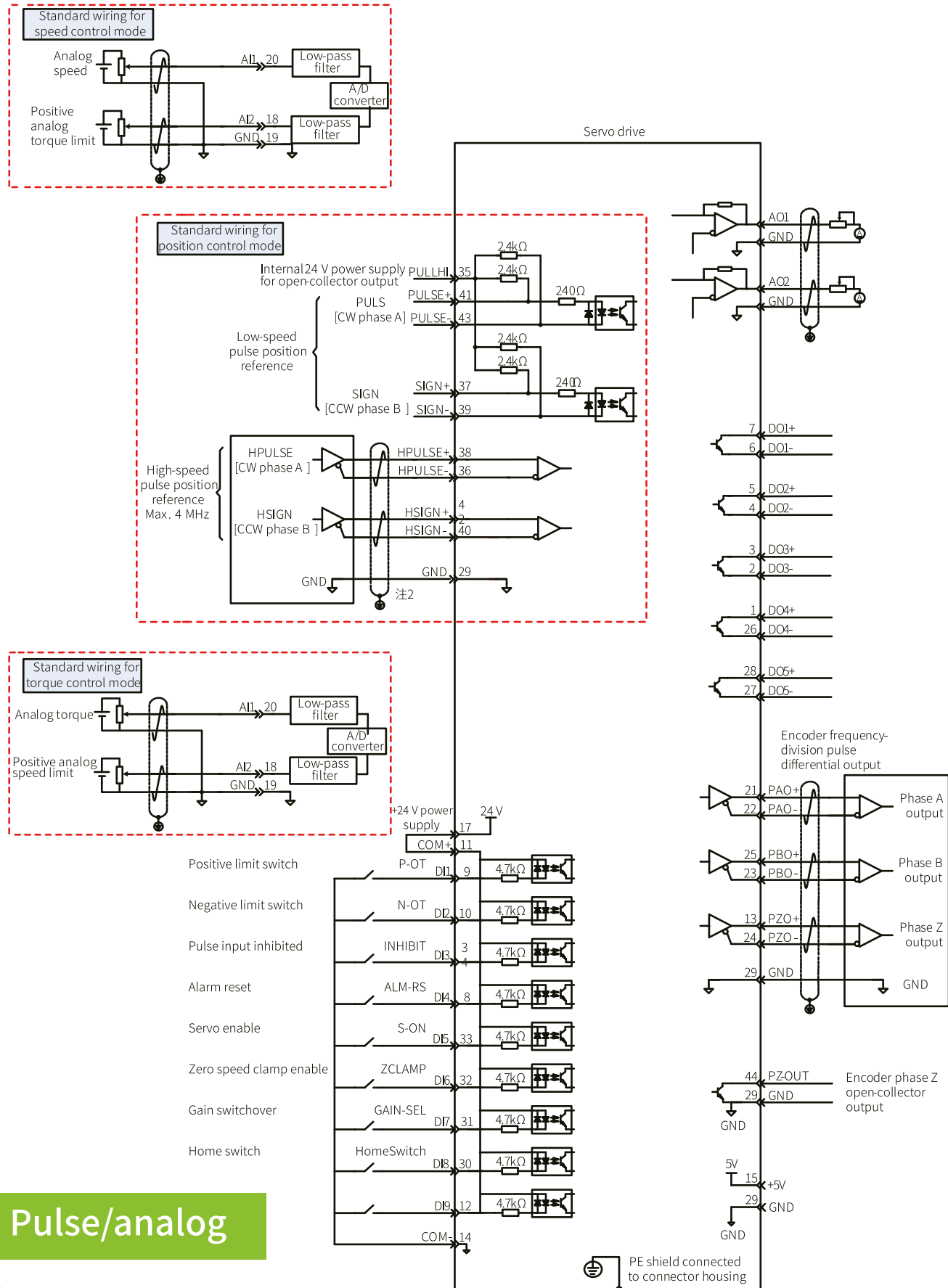

Pulse/analog

# IS620N servo drive configuration

Wiring example for single-phase 220 V system with EtherCAT network

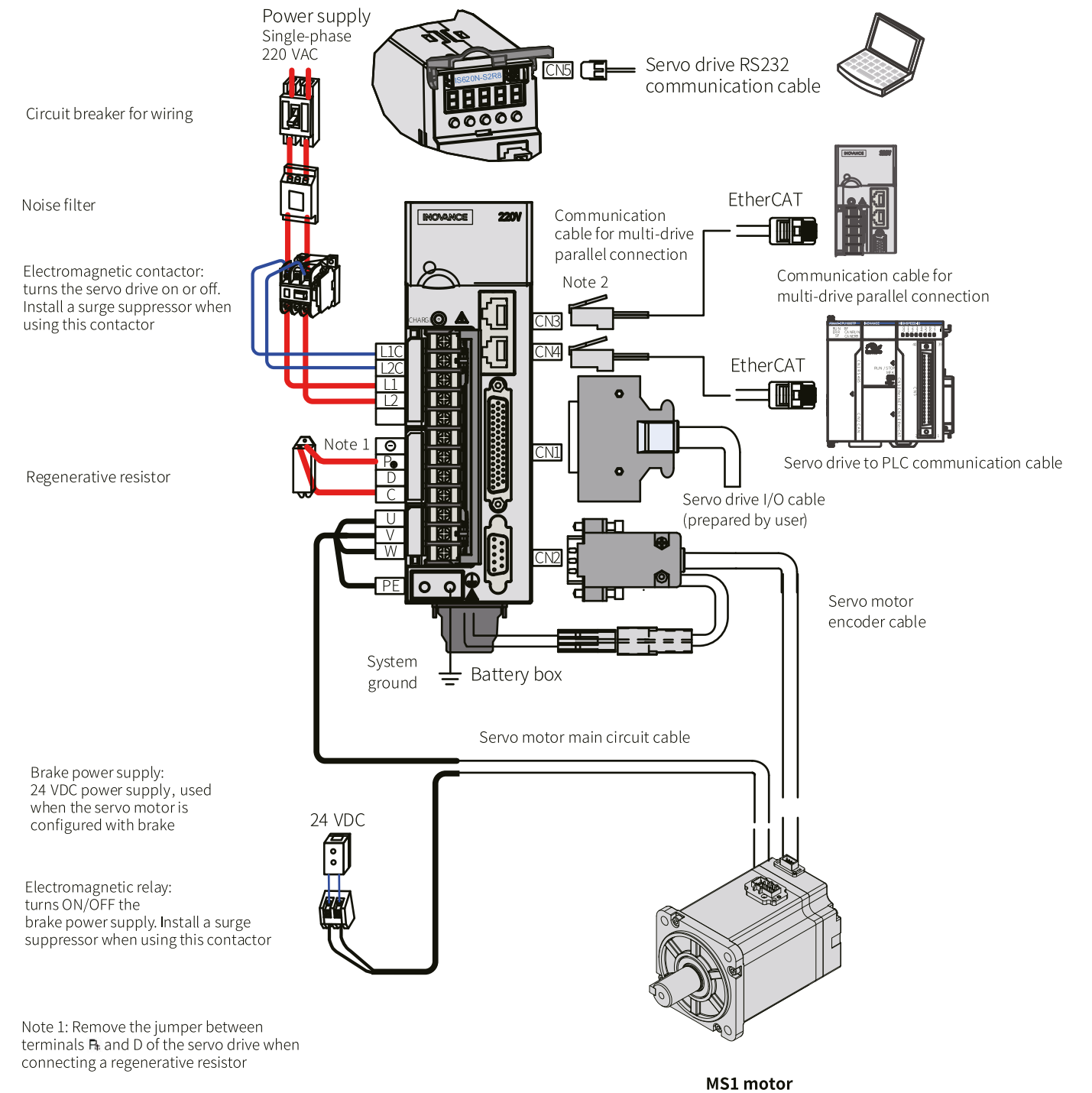

EtherCAT

# IS620N servo drive configuration

Wiring example for three-phase 220 V/380 V system with EtherCAT network

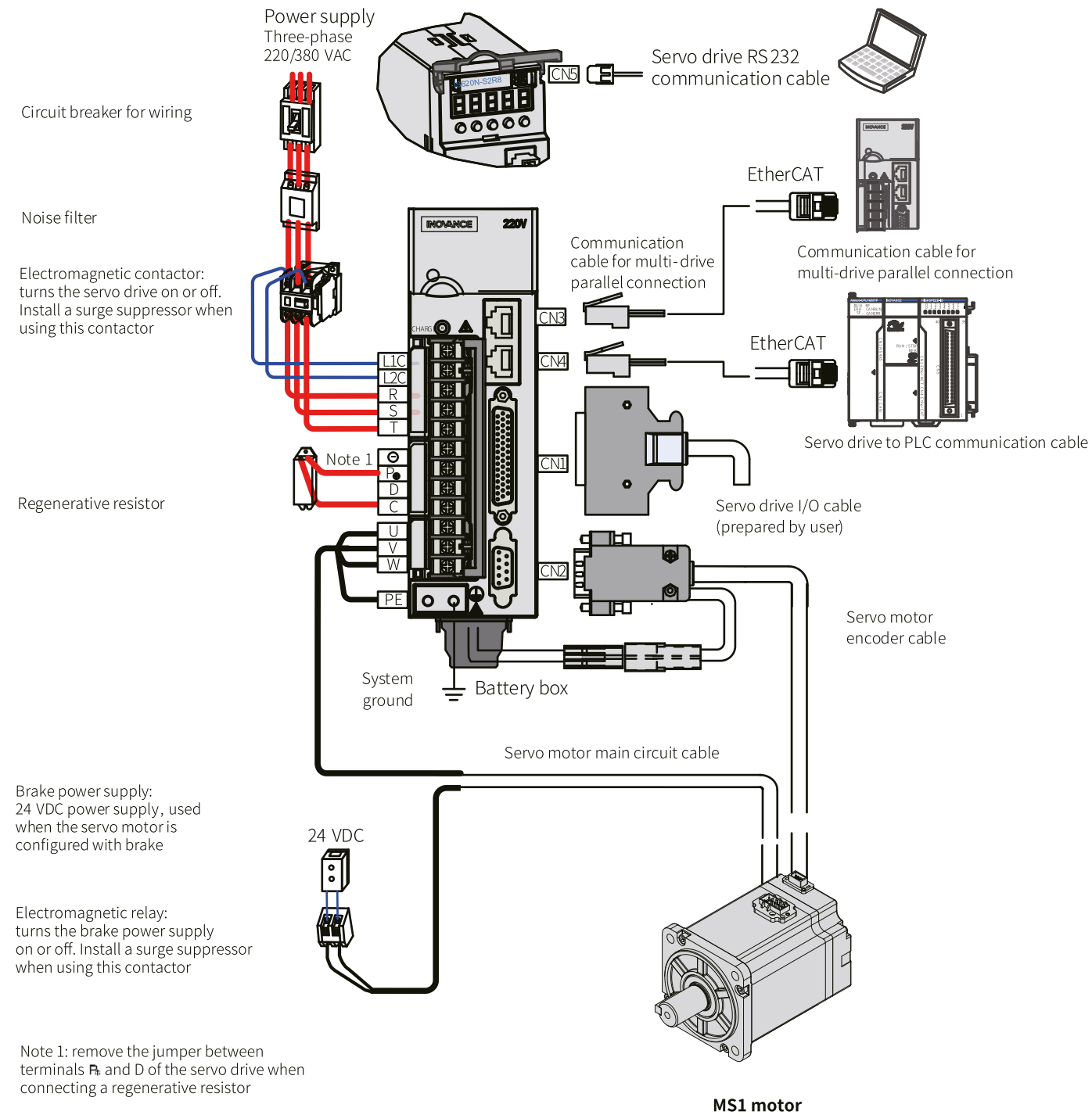

# IS620N servo drive connection diagram

Standard wiring for EtherCAT communication

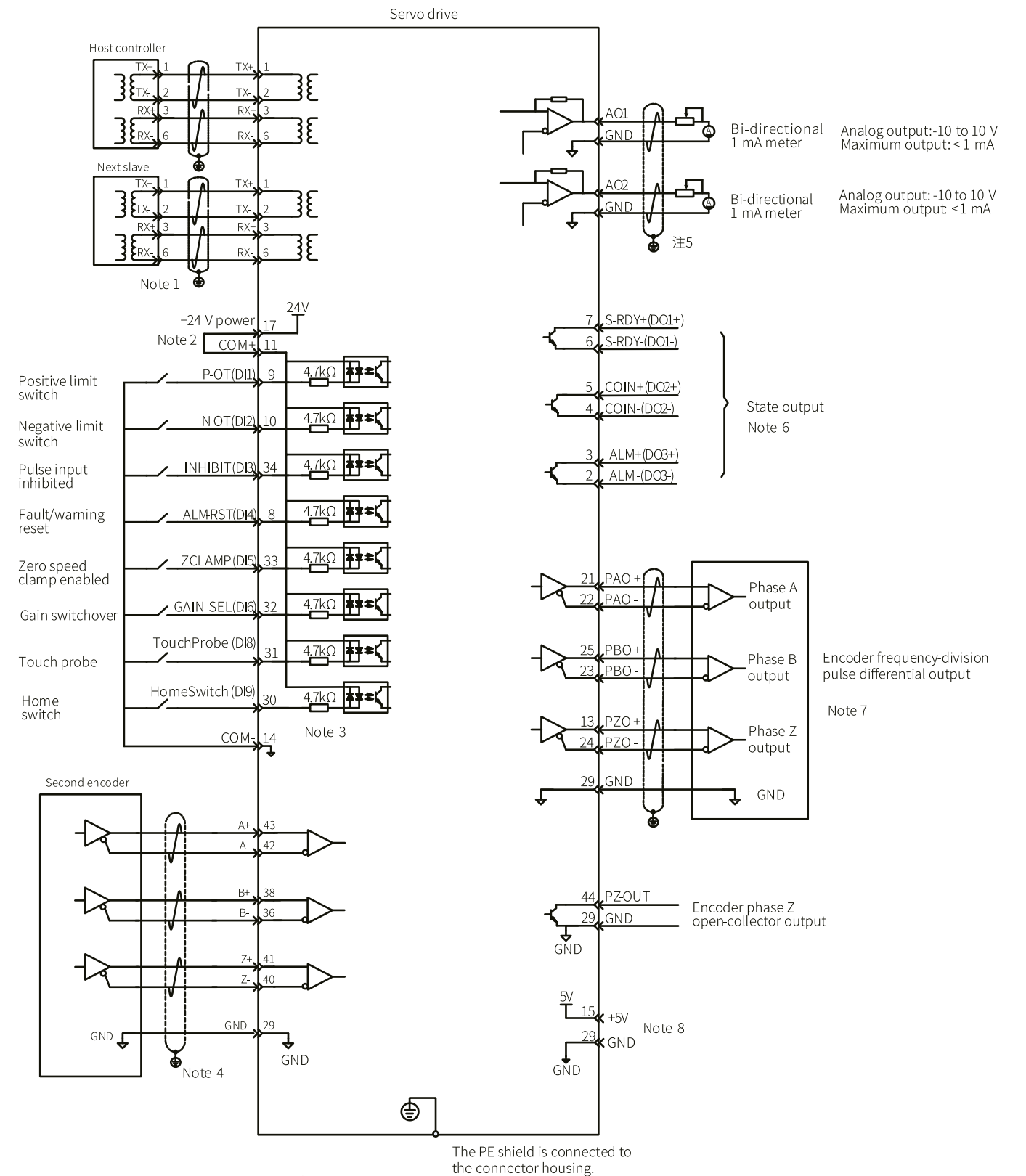

# IS620N EtherCAT overview



EtherCAT is a high performance, flexible, cost-effective technology

## Open technology

EtherCAT is a high-performance, easy-to-use industrial Ethernet technology with a flexible topology. CoE (CAN application protocol over EtherCAT) is the most commonly used EtherCAT communication protocol for acyclic data access. CoE also provides a mechanism to configure PDOs for cyclic data exchange.

The drive profile CiA402 (IEC61800-7-201) is mapped to EtherCAT. Our IS620N servo drive complies with the CiA 402 profile.

CiA 402 profile type (CoE)	
■ Profile position mode (PP)	
■ Profile velocity mode (PV)	
■ Profile torque mode (PT)	
■ Homing mode (HM)	
■ Cyclic synchronous position mode (CSP)	
■ Cyclic synchronous velocity mode (CSV)	
■ Cyclic synchronous torque mode (CST)	

## Example of EtherCAT network system with IS620N servo drive

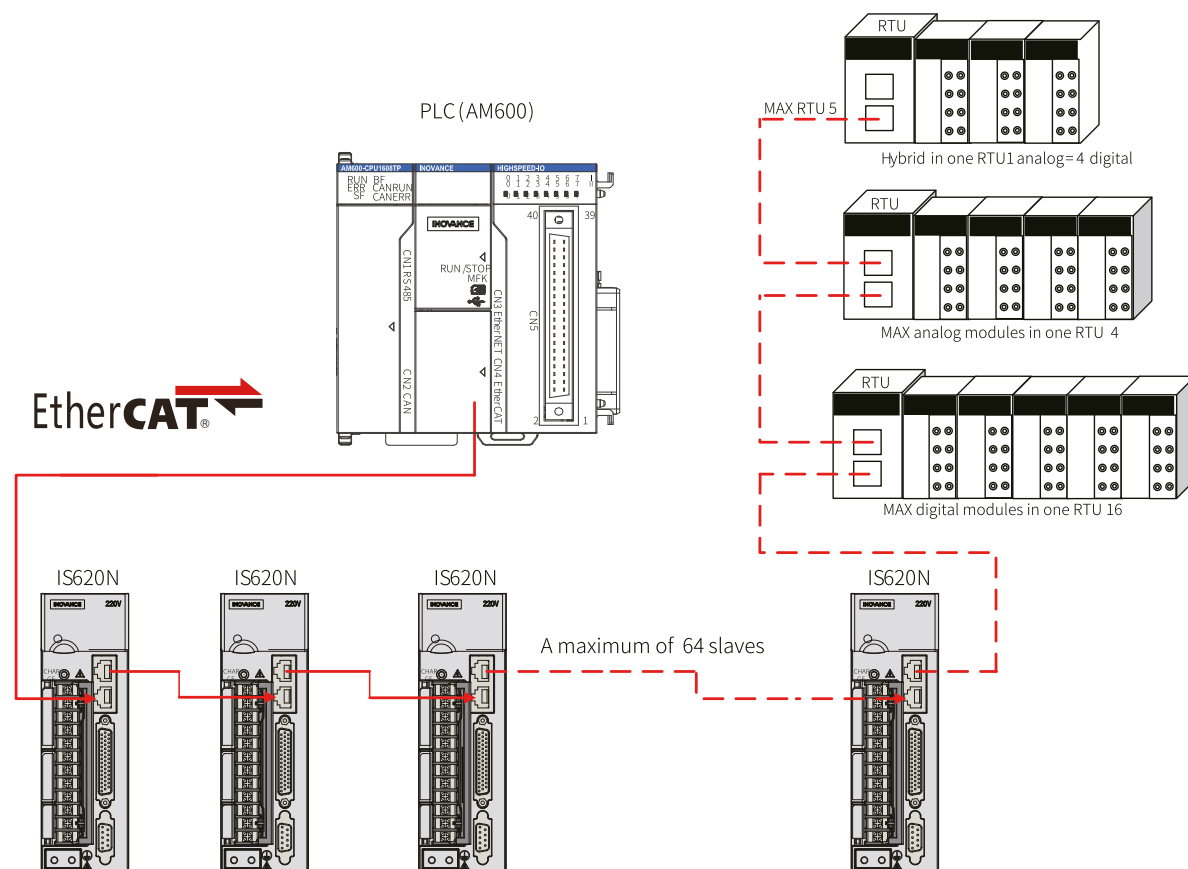

# IS620N EtherCAT overview



## Network configuration using TwinCAT platform with IS620N

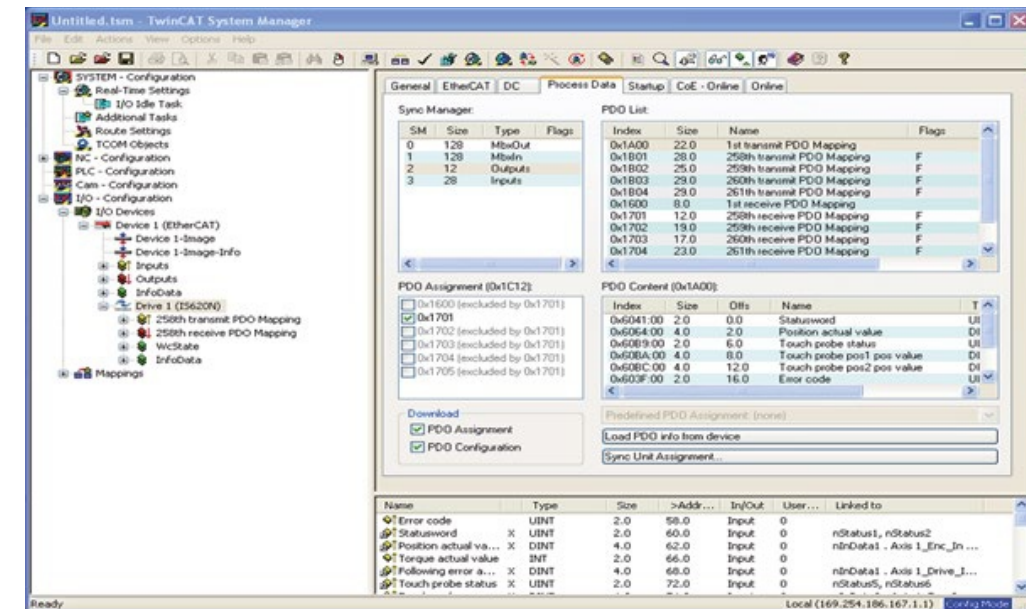

Configuration of the IS620N drive is automatically recognized by the controller using the XML library related to the drives.

## Network configuration using third party controller platform with IS620N

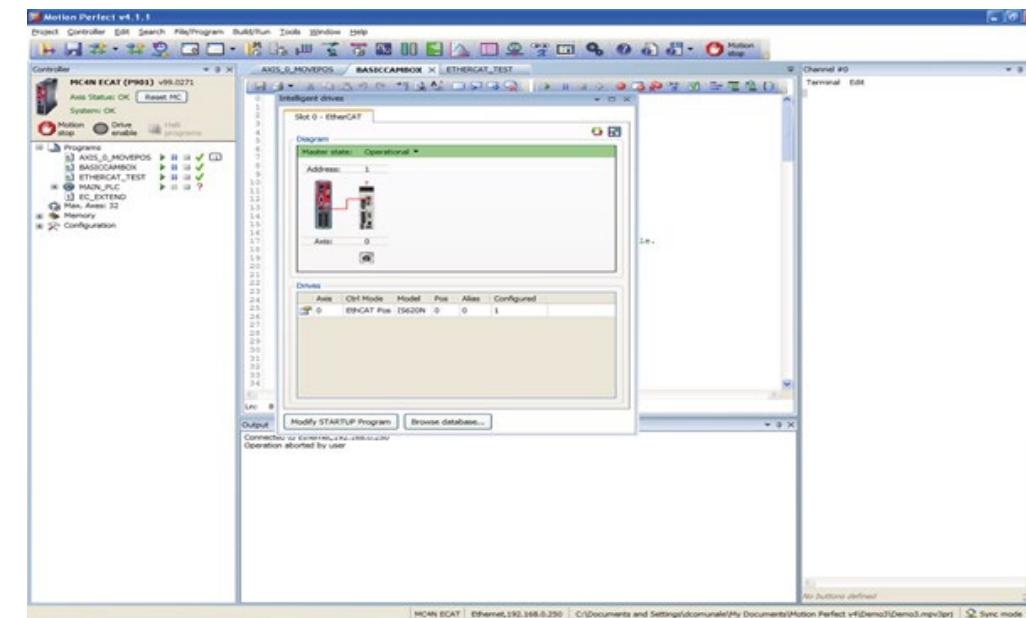

Configuration of the IS620N drive is automatically recognized by the controller using the XML library related to the drives.

# IS620N EtherCAT overview



EtherCAT is a high performance, flexible, cost-effective technology

## Network configuration using AM600 platform with IS620N

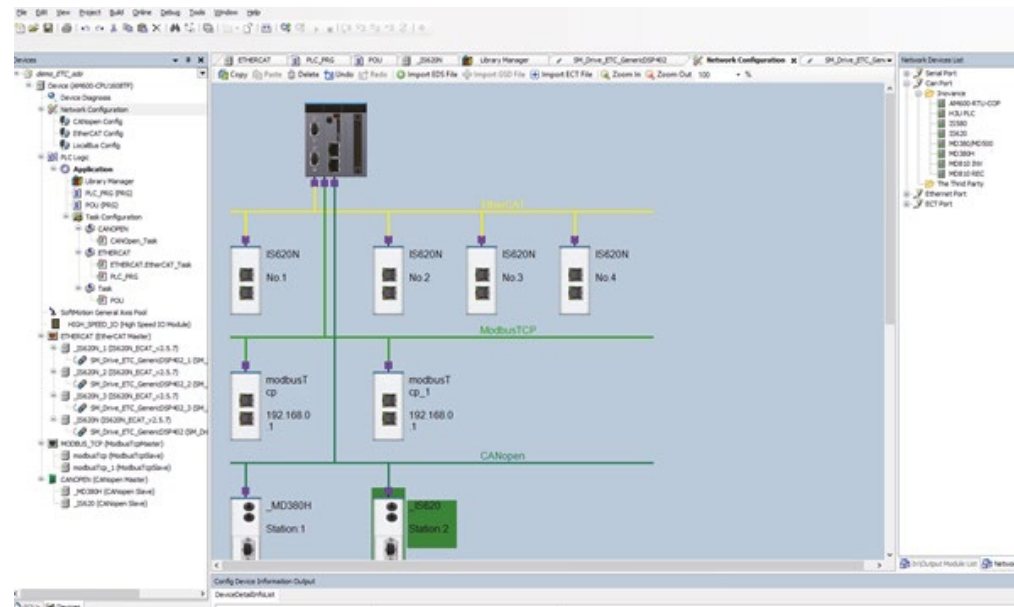

AM600 platform example of EtherCAT configuration + CANopen module + Modbus TCP/IP for service and commissioning.

# IS620P-CO CANopen overview



CANopen networks are used in many embedded machine control systems

The internationally standardized CiA 402 device profile for drives and motion controllers (IEC 61800-7-201/301) is the most widely implemented solution.

The CiA 402 profile specifies several operation modes in detail. They are selectable by means of a command, and confirmed at the application level.

CANopen supports master/slave mode, the IS620P only supports slave mode. It supports only one master node in the network, the address of master/slave nodes is between 1 and 63, different for each node.

- CiA 402
- 0-Speed mode
  - 1-Position mode
  - 2-Torque mode
  - 3-Speed mode<->Torque mode
  - 4-Position mode<->Speed mode
  - 5-Position mode<->Torque mode
  - 6-Position<->speed<->Torque mode

Modes 3-6 can be changed on the fly

# PC software: InoServoShop

Easy to use engineering tool for commissioning and diagnostics

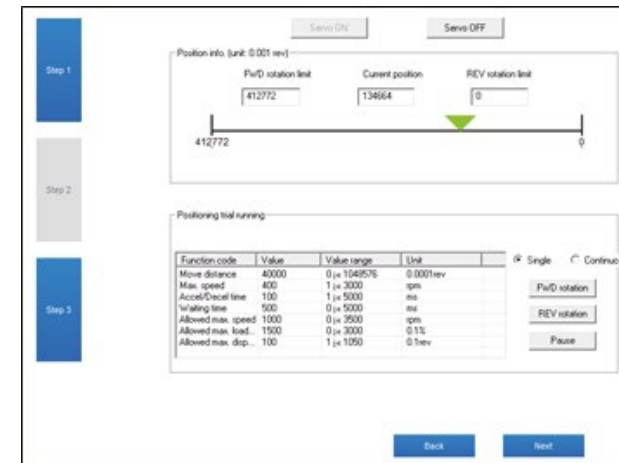

Easy auto-tuning using position JOG and self-adjustment

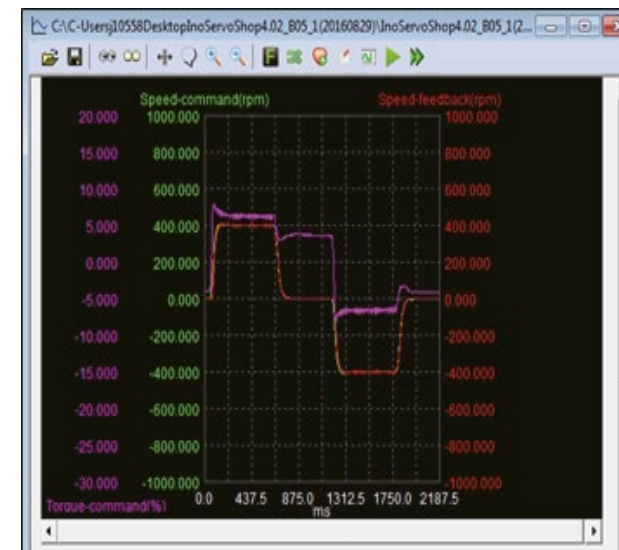

Oscilloscope function to monitor servo motor performance

### Function – setting, monitoring

- Read/write parameters
- Real-time monitoring parameters
- DI/DO graphic configuration
- Oscilloscope (trace)
- Software reset
- JOG run
- Automatic U-V current phase calibration

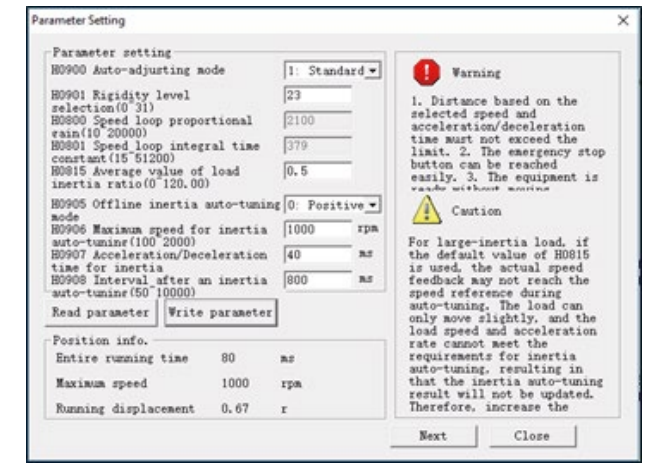

Inertia auto-tuning calculates estimated inertia of load

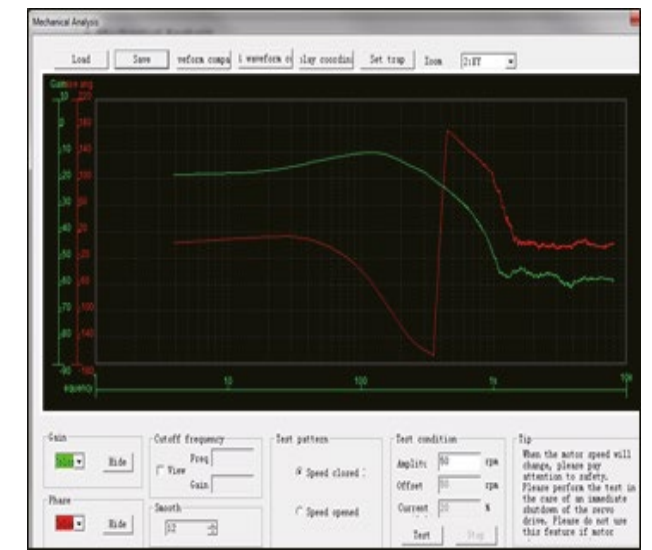

Mechanical analysis to diagnose natural frequency of system

### Function – adjustment

- Automatic gain tuning
  - Inertia auto-tuning
  - Mechanical analysis
- ### Advanced function
- Electronic CAM



# MS1 servo motor technical data

Reliable operation, wide selection

## Model designation

**MS1 H1 - 75B 30C B - A3 3 1 Z - INT**

① ② ③ ④ ⑤ ⑥ ⑦ ⑧ ⑨ ⑩

① Series: MS1 series servo motor	④ Rated speed A: x 1 B: x 10 C: x 100 D: x 1,000 E: x 10,000 E.g. 30C : 3,000 RPM	⑦ Motor shaft 1: plain 2: keyed 3: keyed + tapped hole 5: tapped hole
② Inertia H1: low inertia, 40/60/80 mm flange H2: low inertia, 100/130 mm flange H3: medium inertia 130/180 mm flange H4: medium inertia 60/80 mm flange	⑤ Voltage class B: 220 V D: 380 V	⑧ Brake, oil sealing 0: none 1: oil sealing 2: brake 4: brake + oil sealing
③ Rated power A: x 1 B: x 10 C: x 100 D: x 1,000 E: x 10,000 E.g. 75B: 750 W; 15C: 1,500 W	⑥ Encoder type A3: 23-bit multi-turn absolute	⑨ Motor configuration Y: 8 pole Z: 10 pole
		⑩ INT: international version

Servo motor model	Rated output [kW]	Rated torque [Nm]	Peak torque [Nm]	Rated current [Arms]	Peak current [Arms]	Rated speed [RPM]	Peak speed [RPM]	Torque constant [Nm/Arms]	Rotor inertia [10 <sup>-3</sup> kgm <sup>2</sup> ]	Voltage [V]	
MS1H1 (N <sub>rated</sub> = 3,000 RPM, N <sub>max</sub> = 6,000 RPM)											
MS1H1-05B30CB-XXXXZ-INT	0.05	0.16	0.56	1.3	4.7	3,000	6,000	0.15	0.026 (0.028)	220	
MS1H1-10B30CB-XXXXZ-INT	0.1	0.32	1.12	1.3	4.7			0.26	0.041 (0.043)		
MS1H1-20B30CB-XXXXZ-INT	0.2	0.64	2.24	1.5	5.8			0.46	0.207 (0.220)		
MS1H1-40B30CB-XXXXZ-INT	0.4	1.27	4.46	2.8	10.1			0.53	0.376 (0.390)		
MS1H1-55B30CB-XXXXZ-INT	0.55	1.75	6.13	3.8	15.0			0.49	1.06		
MS1H1-75B30CB-XXXXZ-INT	0.75	2.39	8.36	4.8	16.9			0.58	1.38 (1.43)		
MS1H1-10C30CB-XXXXZ-INT	1.0	3.18	11.1	7.6	28			0.46	1.75		
MS1H2 (N <sub>rated</sub> = 3,000 RPM, N <sub>max</sub> = 5,000/6,000 RPM)											
MS1H2-10C30CB-XXXXZ-INT	1.0	3.18	9.54	7.5	23	3,000	6,000	0.43	1.87 (3.12)	220	
MS1H2-15C30CB-XXXXZ-INT	1.5	4.9	14.7	10.8	32		5,000	0.45	2.46 (3.71)		
MS1H2-10C30CD-XXXXZ-INT	1.0	3.18	9.54	3.65	11		5,000	6,000	0.87	1.87 (3.12)	380
MS1H2-15C30CD-XXXXZ-INT	1.5	4.9	14.7	4.5	14			1.09	2.46 (3.71)		
MS1H2-20C30CD-XXXXZ(-S4)-INT	2.0	6.36	19.1	5.89	20			1.08	3.06 (4.31)		
MS1H2-25C30CD-XXXXZ(-S4)-INT	2.5	7.96	23.9	7.56	25			1.05	3.65 (4.9)		
MS1H2-30C30CD-XXXXZ(-S4)-INT	3.0	9.8	29.4	10	30			0.98	7.72 (7.72)		
MS1H2-40C30CD-XXXXZ(-S4)-INT	4.0	12.6	37.8	13.6	40.8			0.93	12.1 (14.6)		
MS1H2-50C30CD-XXXXZ(-S4)-INT	5.0	15.8	47.6	16	48			1.07	15.4 (17.9)		
MS1H3 (N <sub>rated</sub> = 1,500 RPM, N <sub>max</sub> = 3,000 RPM)											
MS1H3-85B15CB-XXXXZ-INT	0.85	5.39	13.5	6.6	16.5	1,500	3,000	0.9	13.3 (14)	220	
MS1H3-13C15CB-XXXXZ-INT	1.3	8.34	20.85	10	25			0.9	17.8 (18.5)		
MS1H3-85B15CD-XXXXZ-INT	0.85	5.39	13.5	3.3	8.25			1.75	13.3 (14)	380	
MS1H3-13C15CD-XXXXZ-INT	1.3	8.34	20.85	5	12.5			1.78	17.8 (18.5)		
MS1H3-18C15CD-XXXXZ-INT	1.8	11.5	28.75	6.6	16.5			1.8	25 (25.7)		
MS1H3-29C15CD-XXXXZ-INT	2.9	18.6	37.2	11.9	28			1.7	55 (57.2)		
MS1H3-44C15CD-XXXXZ-INT	4.4	28.4	71.1	16.5	40.5			1.93	88.9 (90.8)		
MS1H3-55C15CD-XXXXZ-INT	5.5	35	87.6	20.85	52			1.8	107 (109.5)		
MS1H3-75C15CD-XXXXZ-INT	7.5	48	119	25.7	65			1.92	141 (143.1)		
MS1H4 (N <sub>rated</sub> = 3,000 RPM, N <sub>max</sub> = 6,000 RPM)											
MS1H4-40B30CB-XXXXZ-INT	0.4	1.27	4.46	2.8	10.1	3,000	6,000	0.53	0.657 (0.667)	220	
MS1H4-75B30CB-XXXXZ-INT	0.75	2.39	8.36	4.8	16.9			0.58	2 (2.012)		

Notes: the brake version can only work in S4 duty, for example ISMH2-20C30CD-A334Z-S4-INT.

# Servo motor and servo drive combination

	1-phase 220 V		1/3-phase 220 V		3-phase 220 V		
Servo drive							
	SIZE A		SIZE A		SIZE C		
Servo motor	IS620-S1R6I	IS620-S2R8I	IS620-S5R5I	IS620-S7R6I	IS620-S012I		
	MS1H1-05B30CB MS1H1-10B30CB MS1H1-20B30CB	MS1H1-40B30CB MS1H4-40B30CB	MS1H1-55B30CB (no brake) MS1H1-75B30CB MS1H4-75B30CB	MS1H1-10C30CB (no brake) MS1H2-10C30CB MS1H3-85B15CB	MS1H3-13C15CB MS1H2-15C30CB		
Servo drive	3-phase 380 V						
Servo motor	SIZE C			SIZE E			
	IS620-T3R5I	IS620-T5R4I	IS620-T8R4I	IS620-T012I	IS620-T017I	IS620-T021I	IS620-T026I
	MS1H3-85B15CD	MS1H3-13C15CD MS1H2-10C30CD MS1H2-15C30CD	MS1H3-18C15CD MS1H2-20C30CD MS1H2-25C30CD	MS1H3-29C15CD MS1H2-30C30CD	MS1H3-44C15CD MS1H2-40C30CD MS1H2-50C30CD	MS1H3-55C15CD	MS1H3-75C15CD

# Application examples

## Double position loop control

The encoder on the velocity measurement roller reports material speed and position. The servo drive uses closed-loop position control to deliver materials smoothly to pre-set positions, compensating for material slippage and adjusting conveyor gaps. Algorithms in the drive offer dual-PG full closed-loop control; while the drive's filter allows adjustment of speed and position control. To ensure reliable material conveying, runaway protection kicks in when there is a large difference between internal and external loop positions.

Example applications: steel plate cutting, pipe bending, wire stripping

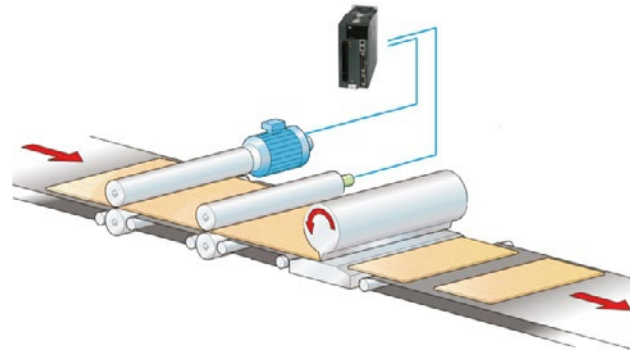

## Changing position control on-the-fly

After an external DI interruption, the motor runs to a pre-set length at the existing speed. This function is given highest priority and, when it is triggered, the servo motor ignores all other position commands.

Example applications: material laying, bearing tube cutting

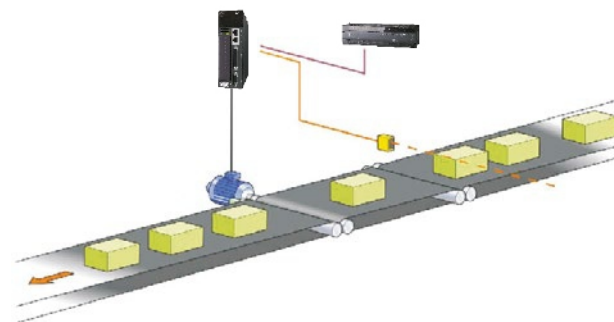

## CANlink communication (optional)

CANlink is an open Inovance protocol, based on CAN bus that can be used to network Inovance HMIs, PLCs and servo and AC drives. It offers simple networking and improved reliability and security, and is suitable for applications with large numbers of DIs and DOs. CANlink 3.0 uses a master/slave model with a maximum of 62 slaves and a highest communication rate of 1M. Standard CANopen is also supported.

Example applications: hoop bending, film cutting, automatic screwing, stacking, plastic injection molding

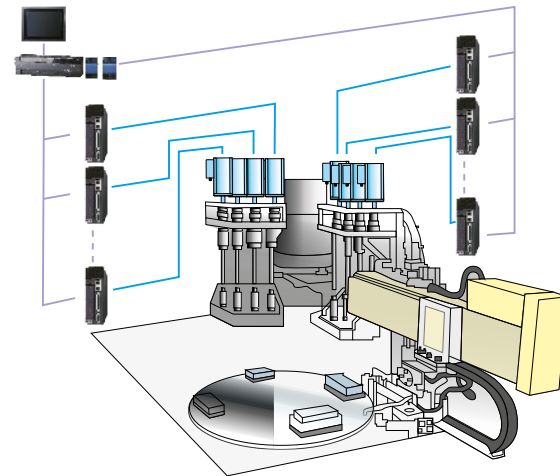

## Multi-position control

Up to 16 relative or absolute positions can be controlled via PLC or manually. This function requires a servo motor with multi-turn absolute encoder to perform the home seek operation. Position-reach signals indicate completion of each phase.

Example applications: longitudinal line cutting, multi-station switching, servo tool holder

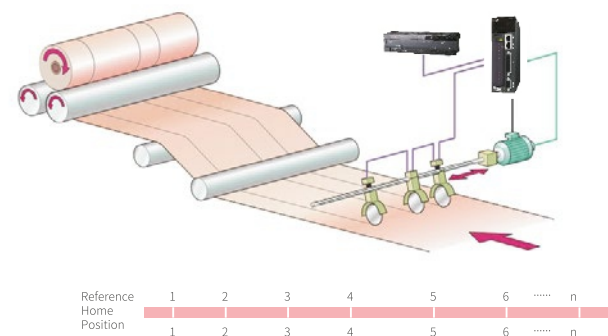

# Servo motor dimensions and drawings

## MS1H1/MS1H4 mounting dimensions ( $N_{rated} = 3,000 \text{ RPM}$ , $N_{max} = 6,000 \text{ RPM}$ )

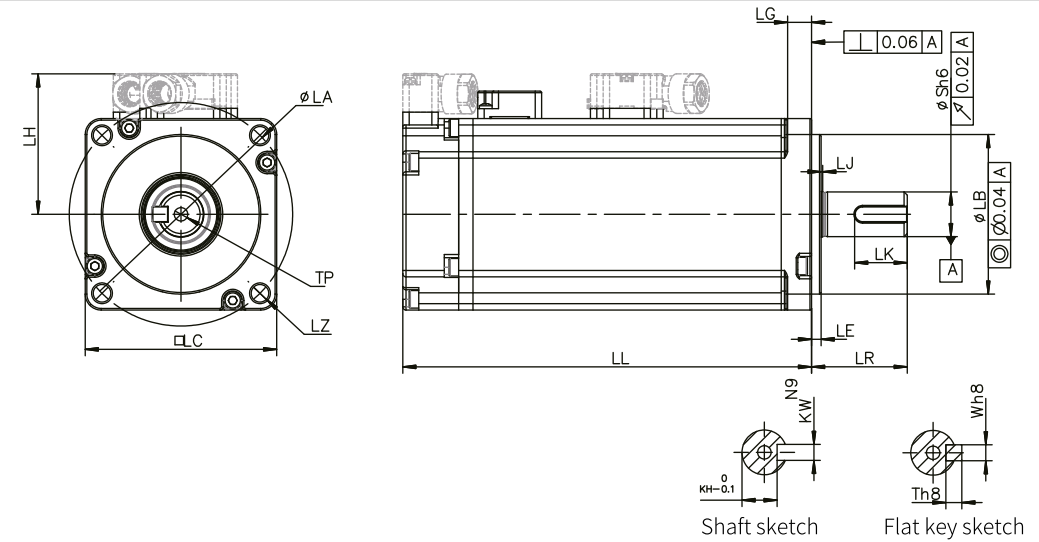

Model	LC (mm)	LL (mm)	LR (mm)	LA (mm)	LZ (mm)	LH (mm)	LG (mm)	LE (mm)	LJ (mm)
MS1H1-05B30CB-XXXXZ-INT	40	65 (96)*	25±0.5	46	2-Φ4.5	34	5	2.5±0.5	0.5±0.35
MS1H1-10B30CB-XXXXZ-INT	40	77.5 (109)*	25±0.5	46	2-Φ4.5	34	5	2.5±0.5	0.5±0.35
MS1H1-20B30CB-XXXXZ-INT	60	72.5 (100)*	30±0.5	70	4-Φ5.5	44	7.5	3±0.5	0.5±0.35
MS1H1-40B30CB-XXXXZ-INT	60	91 (119)*	30±0.5	70	4-Φ5.5	44	7.5	3±0.5	0.5±0.35
MS1H1-55B30CB-XX31Z-INT	80	96.2	35±0.5	90	4-Φ7	54	7.7	3±0.5	0.5±0.35
MS1H1-75B30CB-XXXXZ-INT	80	107 (140)*	35±0.5	90	4-Φ7	54	7.7	3±0.5	0.5±0.35
MS1H1-10C30CB-XX31Z-INT	80	118.2	35±0.5	90	4-Φ7	54	7.7	3±0.5	0.5±0.35
MS1H4-40B30CB-XXXXZ-INT	60	105 (128)*	30±0.5	70	4-Φ5.5	44	7.5	3±0.3	0.5±0.35
MS1H4-75B30CB-XXXXZ-INT	80	117.5 (147.5)*	35±0.5	90	4-Φ7	54	7.7	3±0.3	0.5±0.35

Model	LB (mm)	S (mm)	TP (mm)	LK (mm)	KH (mm)	KW (mm)	W (mm)	T (mm)	Weight (kg)
MS1H1-05B30CB-XXXXZ-INT	30	8	M3×6	15.5	6.2	3	3	3	0.39 (0.50)*
MS1H1-10B30CB-XXXXZ-INT	30	8	M3×6	15.5	6.2	3	3	3	0.45 (0.64)*
MS1H1-20B30CB-XXXXZ-INT	50	14	M5×8	16.5	11	5	5	5	0.78 (1.16)*
MS1H1-40B30CB-XXXXZ-INT	50	14	M5×8	16.5	11	5	5	5	1.11 (1.48)*
MS1H1-55B30CB-XX31Z-INT	70	19	M6×20	25	15.5	6	6	6	1.85
MS1H1-75B30CB-XXXXZ-INT	70	19	M6×20	25	15.5	6	6	6	2.18 (2.82)*
MS1H1-10C30CB-XX31Z-INT	70	19	M6×20	25	15.5	6	6	6	2.55
MS1H4-40B30CB-XXXXZ-INT	50	14	M5×8	16.5	11.0	5	5	5	1.27 (1.62)*
MS1H4-75B30CB-XXXXZ-INT	70	19	M6×20	25	15.5	6	6	6	2.40 (3.04)*

\*Refers to braked version of the motor

# Servo motor dimensions and drawings

MS1H2 mounting dimensions ( $N_{rated} = 3,000 \text{ RPM}$ ,  $N_{max} = 5,000/6,000 \text{ RPM}$ )

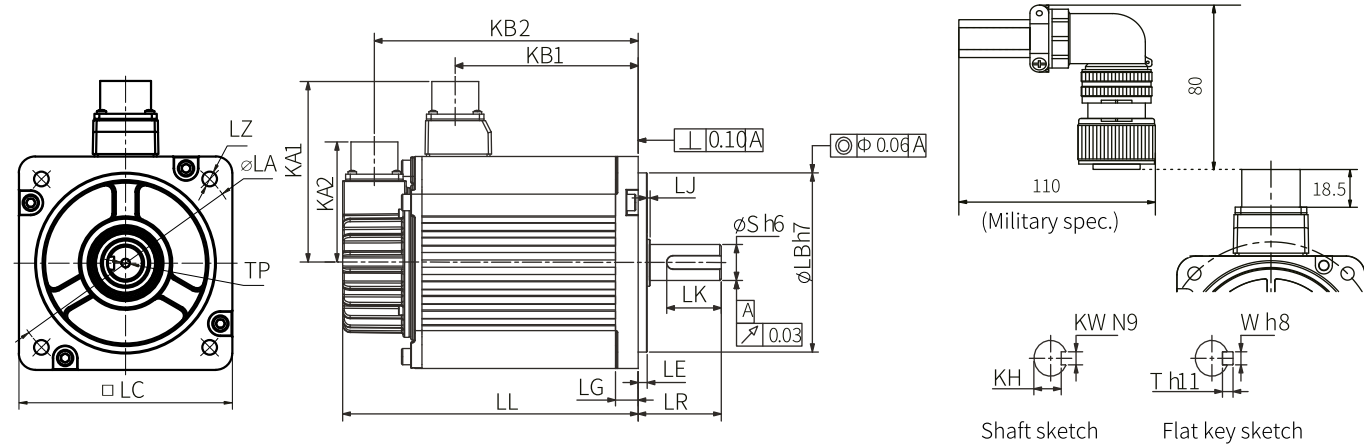

Model	LC (mm)	LL (mm)	LR (mm)	LA (mm)	LZ (mm)	KA1 (mm)	KB1 (mm)	KA2 (mm)	KB2 (mm)	LG (mm)	LE (mm)	LJ (mm)	LB (mm)
MS1H2-10C30CB(D)-XXXXZ-INT	100	164 (213.5)*	45±1	115	4-Φ7	88	94.5 (101)*	74	143.5 (192.5)*	10	5±0.3	2.5±0.75	95
MS1H2-15C30CB(D)-XXXXZ-INT	100	189 (239)*	45±1	115	4-Φ7	88	119.5 (128)*	74	168.5 (219.5)*	10	5±0.3	2.5±0.75	95
MS1H2-20C30CD-XXXXZ(-S4)-INT	100	214 (265)*	45±1	115	4-Φ7	88	144.5 (153)*	74	193.5 (244)*	10	5±0.3	2.5±0.75	95
MS1H2-25C30CD-XXXXZ(-S4)-INT	100	240.5 (290)*	45±1	115	4-Φ7	88	169.5 (178)*	74	218.5 (269)*	10	5±0.3	2.5±0.75	95
MS1H2-30C30CD-XXXXZ(-S4)-INT	130	209.5 (265.5)*	63±1	145	4-Φ9	103	136 (139)*	74	188.5 (244.5)*	14	6±0.3	0.5±0.75	110
MS1H2-40C30CD-XXXXZ(-S4)-INT	130	252 (308)*	63±1	145	4-Φ9	103	178.5 (181.5)*	74	231 (287)*	14	6±0.3	0.5±0.75	110
MS1H2-50C30CD-XXXXZ(-S4)-INT	130	294.5 (350.5)*	63±1	145	4-Φ9	103	221 (224)*	74	273.5 (329.5)*	14	6±0.3	0.5±0.75	110

Model	S (mm)	TP (mm)	LK (mm)	KH (mm)	KW (mm)	W (mm)	T (mm)	Weight (kg)	Connector	Power side (incl. power brake side)	Encoder side
MS1H2-10C30CB(D)-XXXXZ-INT	24	M8×16	36	20 <sup>0</sup> <sub>-0.2</sub>	8	8	7	5.11 (6.41)*	Aviation plug	MI-DTL-5015 3102E20-18P	MI-DTL-5015 3102E20-29P
MS1H2-15C30CB(D)-XXXXZ-INT	24	M8×16	36	20 <sup>0</sup> <sub>-0.2</sub>	8	8	7	6.22 (7.52)*			
MS1H2-20C30CD-XXXXZ(-S4)-INT	24	M8×16	36	20 <sup>0</sup> <sub>-0.2</sub>	8	8	7	7.39 (8.7)*			
MS1H2-25C30CD-XXXXZ(-S4)-INT	24	M8×16	36	20 <sup>0</sup> <sub>-0.2</sub>	8	8	7	8.55 (9.8)*			
MS1H2-30C30CD-XXXXZ(-S4)-INT	28	M8×20	54	24 <sup>0</sup> <sub>-0.2</sub>	8	8	7	10.73 (13.2)*	Aviation plug	MI-DTL-5015 3102E20-18P	MI-DTL-5015 3102E20-29P
MS1H2-40C30CD-XXXXZ(-S4)-INT	28	M8×20	54	24 <sup>0</sup> <sub>-0.2</sub>	8	8	7	15.43 (17.9)*			
MS1H2-50C30CD-XXXXZ(-S4)-INT	28	M8×20	54	24 <sup>0</sup> <sub>-0.2</sub>	8	8	7	16.2 (18.7)*			

\*Refers to braked version of the motor

# Servo motor dimensions and drawings

MS1H3 mounting dimensions ( $N_{rated} = 1,500 \text{ RPM}$ ,  $N_{max} = 3,000 \text{ RPM}$ )

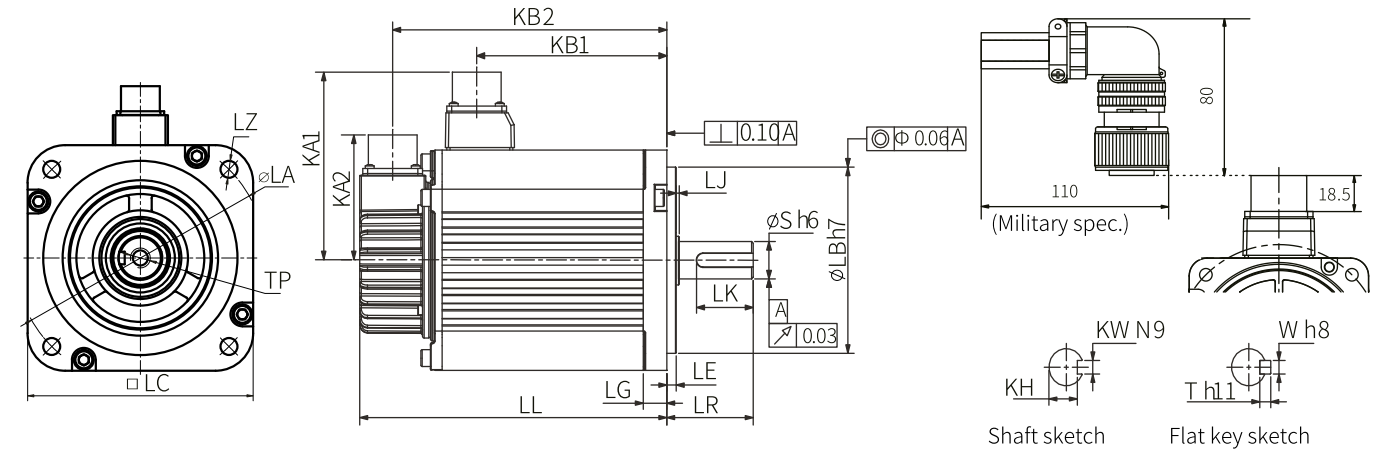

Model	LC (mm)	LL (mm)	LR (mm)	LA (mm)	LZ (mm)	KA1 (mm)	KB1 (mm)	KA2 (mm)	KB2 (mm)	LG (mm)	LE (mm)	LJ (mm)	LB (mm)
MS1H3-85B15CB(D)-XXXXZ-INT	130	146 (182)*	55±1	145	4-Φ9	103	72.5	74	125 (161)*	14	4	0.5±0.75	110
MS1H3-13C15CB(D)-XXXXZ-INT	130	163 (199)*	55±1	145	4-Φ9	103	89.5	74	142 (178)*	14	4	0.5±0.75	110
MS1H3-18C15CD-XXXXZ-INT	130	181 (217)*	55±1	145	4-Φ9	103	107.5	74	160 (196)*	14	4	0.5±0.75	110
MS1H3-29C15CD-XXXXZ-INT	180	197 (273)*	79±1	200	4-Φ13.5	138	136 (134)*	74	177 (253)*	18	3.2±0.3	0.3±0.75	114.3
MS1H3-44C15CD-XXXXZ-INT	180	230 (307)*	79±1	200	4-Φ13.5	138	169 (167)*	74	210 (286)*	18	3.2±0.3	0.3±0.75	114.3
MS1H3-55C15CD-XXXXZ-INT	180	274 (350)*	113±1	200	4-Φ13.5	138	213 (211)*	74	254 (330)*	18	3.2±0.3	0.3±0.75	114.3
MS1H3-75C15CD-XXXXZ-INT	180	330 (407)*	113±1	200	4-Φ13.5	138	269 (267)*	74	310 (386)*	18	3.2±0.3	0.3±0.75	114.3

Model	S (mm)	TP (mm)	LK (mm)	KH (mm)	KW (mm)	W (mm)	T (mm)	Weight (kg)	Connector	Power side (incl. power brake side)	Encoder side
MS1H3-85B15CB(D)-XXXXZ-INT	22	M6×20	36	18 <sup>0</sup> <sub>-0.2</sub>	8	8	7	7 (8)*	Aviation plug	MI-DTL-5015 3102E20-18P	MI-DTL-5015 3102E20-29P
MS1H3-13C15CB(D)-XXXXZ-INT	22	M6×20	36	18 <sup>0</sup> <sub>-0.2</sub>	8	8	7	8 (9.5)*			
MS1H3-18C15CD-XXXXZ-INT	22	M6×20	36	18 <sup>0</sup> <sub>-0.2</sub>	8	8	7	9.5 (11)*			
MS1H3-29C15CD-XXXXZ-INT	35	M12×25	65	30 <sup>0</sup> <sub>-0.2</sub>	10	10	8	15 (25)*	Aviation plug	MI-DTL-5015 3102E20-22P	MI-DTL-5015 3102E20-29P
MS1H3-44C15CD-XXXXZ-INT	35	M12×25	65	30 <sup>0</sup> <sub>-0.2</sub>	10	10	8	19.5 (30)*			
MS1H3-55C15CD-XXXXZ-INT	42	M16×32	96	37 <sup>0</sup> <sub>-0.2</sub>	12	12	8	28 (38)*			
MS1H3-75C15CD-XXXXZ-INT	42	M16×32	96	37 <sup>0</sup> <sub>-0.2</sub>	12	12	8	32 (42)*			

\*Refers to braked version of the motor

# Servo motor torque VS speed graph

A (continuous operation area) & B (short term operation area)

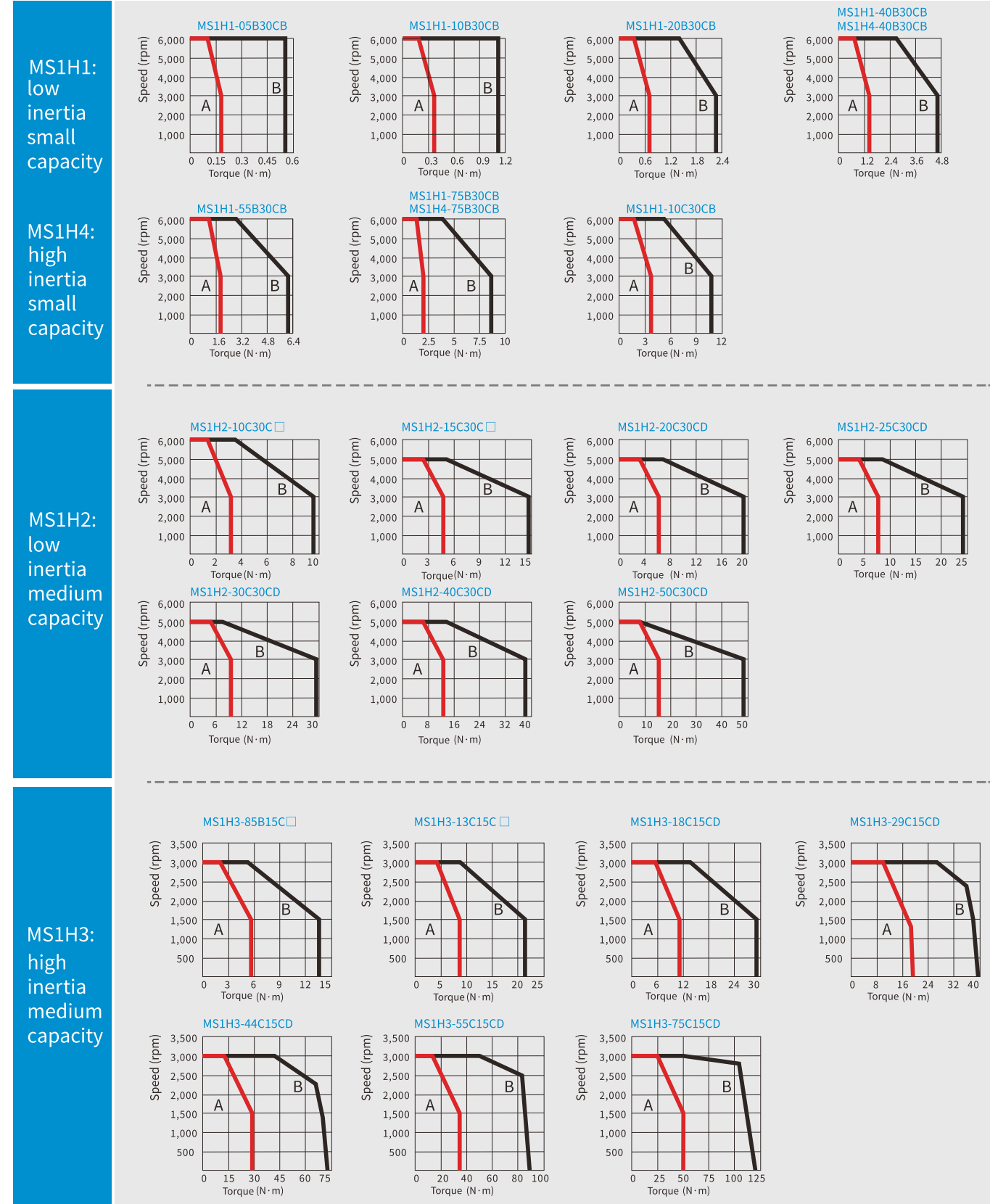

# Servo motor overload characteristics graph

## MS1H1/MS1H2/MS1H3/MS1H4

Load in %	Deceleration time(s)
120	230
130	80
140	40
150	30
160	20
170	17
180	15
190	12
200	10
210	8.5
220	7
230	6
240	5.5
250	5
300	3
350	2

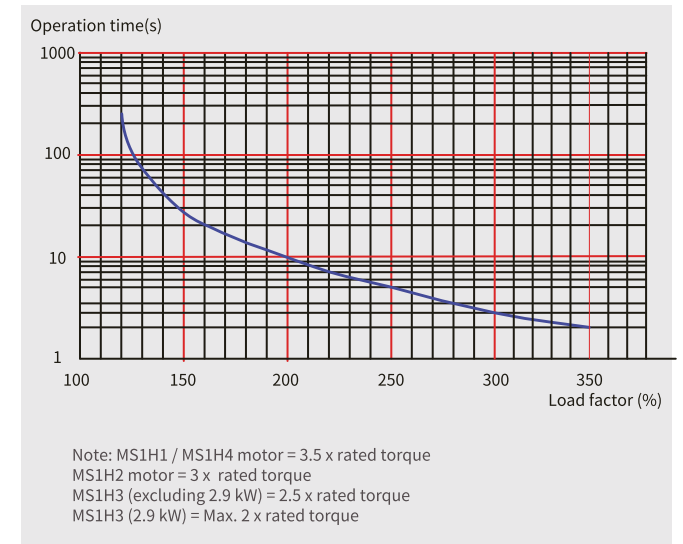

## Allowable radial load, axial load

Servo motor model	Allowable radial load (N)	Allowable axial load (N)
MS1H1-05B30CB-A3XXZ-INT	78	54
MS1H1-10B30CB-A3XXZ-INT	78	54
MS1H1-20B30CB-A3XXZ-INT	245	74
MS1H1-40B30CB-A3XXZ-INT	245	74
MS1H1-55B30CB-A3X1Z-INT	392	147
MS1H1-75B30CB-A3XXZ-INT	392	147
MS1H1-10C30CB-A3X1Z-INT	392	147
MS1H2-10C30CX-A3X1Z-INT	686	196
MS1H2-15C30CX-A3X1Z-INT	686	196
MS1H2-20C30CD-A3XXZ(-S4)-INT	686	196
MS1H2-25C30CD-A3XXZ(-S4)-INT	686	196
MS1H2-30C30CD-A3XXZ(-S4)-INT	980	392
MS1H2-40C30CD-A3XXZ(-S4)-INT	1,176	392
MS1H2-50C30CD-A3XXZ(-S4)-INT	1,176	392
MS1H3-85B15CX-A3XXZ-INT	686	196
MS1H3-13C15CX-A3XXZ-INT	686	196
MS1H3-18C15CD-A3XXZ-INT	686	196
MS1H3-29C15CD-A3XXZ-INT	1,470	490
MS1H3-44C15CD-A3XXZ-INT	1,470	490
MS1H3-55C15CD-A3XXZ-INT	1,764	588
MS1H3-75C15CD-A3XXZ-INT	1,764	588
MS1H4-40B30CB-A3XXZ-INT	245	74
MS1H4-75B30CB-A3XXZ-INT	392	147

## Brake specifications

Model	Holding torque (Nm)	Input voltage (V) (±10%)	Resistance (Ω)	Input current (A)(±7%)	Opening time (ms)	Closing time (ms)	Power (W)
MS1H1-05/10B	0.3	24	96	0.23~0.27	10	30	6.1
MS1H1-20B/40B	1.5		82.3	0.25~0.34	20	50	7.6
MS1H1-75B	2.5		50.1	0.40~0.57	25	60	8
MS1H2-10C/15C/20C/25C	8		25	0.81~1.14	30	90	20
MS1H2-30C/40C/50C	16		21.3	0.95~1.33	60	120	19.4
MS1H3-85B/13C/18C	12		21.3	0.95~1.33	60	120	19.4
MS1H3-29C/44C/55C/75C	48		13.7	1.47~2.07	100	230	40
MS1H4-40B	1.5		82.3	0.25~0.34	20	50	7.6
MS1H4-75B	2.5		50.1	0.40~0.57	25	60	8

# Servo motor encoder and power wiring details

## Motor connection descriptions

-40, -60, -80 frame size motor end connector



Motor end power 6-pin connector

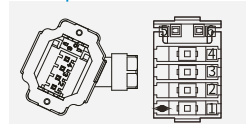

Pin No.	Signal
1	PE
2	W
3	V
4	U
5	Brake (no polarity)
6	

Motor end encoder 7-pin connector

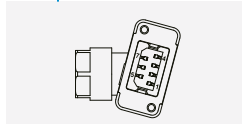

Pin No.	Signal
1	PS+
2	PS-
3	DC+
4	DC-
5	+5V
6	0V
7	PE

-100, -130 frame size motor end connector



Motor end power 20-18 military connector

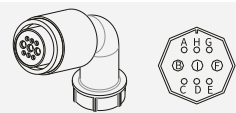

MIL-DTL-5015 series 3108E20-18S			
Y-series terminal		Z-series terminal	
Pin No.	Signal	Pin No.	Signal
B	U	B	U
I	V	I	V
F	W	F	W
G	PE	G	PE
C	Brake (no polarity)		
E			

-180 frame size motor end connector

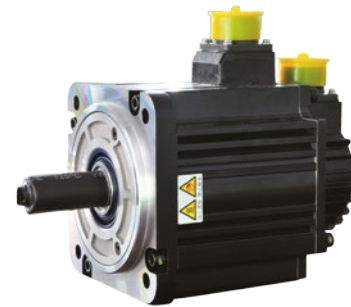

Motor end power 20-22 military connector

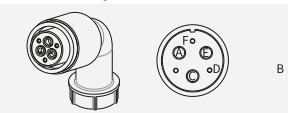

MIL-DTL-5015 series 3108E20-22S			
Y-series terminal		Z-series terminal	
Pin No.	Signal	Pin No.	Signal
A	U	A	U
C	V	C	V
E	W	E	W
F	PE	F	PE
		B	Brake (no polarity)
		D	

# Motor power cable item codes

Model	Servo motor power cable (front outlet)					
	Without brake			With brake		
	L = 3.0 m	L = 5.0 m	L = 10.0 m	L = 3.0 m	L = 5.0 m	L = 10.0 m
MS1H1	S6-L-M007-3.0	S6-L-M007-5.0	S6-L-M007-10.0	S6-L-B007-3.0	S6-L-B007-5.0	S6-L-B007-10.0
MS1H4	S6-L-M007-3.0	S6-L-M007-5.0	S6-L-M007-10.0	S6-L-B007-3.0	S6-L-B007-5.0	S6-L-B007-10.0

Model	Servo motor power cable (back outlet)					
	Without brake			With brake		
	L = 3.0 m	L = 5.0 m	L = 10.0 m	L = 3.0 m	L = 5.0 m	L = 10.0 m
MS1H1	S6-L-M008-3.0	S6-L-M008-5.0	S6-L-M008-10.0	S6-L-B008-3.0	S6-L-B008-5.0	S6-L-B008-10.0
MS1H4	S6-L-M008-3.0	S6-L-M008-5.0	S6-L-M008-10.0	S6-L-B008-3.0	S6-L-B008-5.0	S6-L-B008-10.0

Model	Servo motor power cable					
	Without brake			With brake		
	L = 3.0 m	L = 5.0 m	L = 10.0 m	L = 3.0 m	L = 5.0 m	L = 10.0 m
MS1H2	S6-L-M011-3.0	S6-L-M011-5.0	S6-L-M011-10.0	S6-L-B011-3.0	S6-L-B011-5.0	S6-L-B011-10.0
MS1H3 (1.8 kW & below)	S6-L-M011-3.0	S6-L-M011-5.0	S6-L-M011-10.0	S6-L-B011-3.0	S6-L-B011-5.0	S6-L-B011-10.0
MS1H3 (2.9 kW)	S6-L-M012-3.0	S6-L-M012-5.0	S6-L-M012-10.0	S6-L-B012-3.0	S6-L-B012-5.0	S6-L-B012-10.0
MS1H3 (above 2.9 kW)	S6-L-M022-3.0	S6-L-M022-5.0	S6-L-M022-10.0	S6-L-B022-3.0	S6-L-B022-5.0	S6-L-B022-10.0

## Motor encoder cable item codes

Model	Servo motor encoder cable (front outlet)					
	23-bit encoder (single turn)			23-bit encoder (multi-turn)		
	L = 3.0 m	L = 5.0 m	L = 10.0 m	L = 3.0 m	L = 5.0 m	L = 10.0 m
MS1H1	S6-L-P014-3.0	S6-L-P014-5.0	S6-L-P014-10.0	S6-L-P024-3.0	S6-L-P024-5.0	S6-L-P024-10.0
MS1H4	S6-L-P014-3.0	S6-L-P014-5.0	S6-L-P014-10.0	S6-L-P024-3.0	S6-L-P024-5.0	S6-L-P024-10.0

Model	Servo motor encoder cable (back outlet)					
	23-bit encoder (single turn)			23-bit encoder (multi-turn)		
	L = 3.0 m	L = 5.0 m	L = 10.0 m	L = 3.0 m	L = 5.0 m	L = 10.0 m
MS1H1	S6-L-P015-3.0	S6-L-P015-5.0	S6-L-P015-10.0	S6-L-P025-3.0	S6-L-P025-5.0	S6-L-P025-10.0
MS1H4	S6-L-P015-3.0	S6-L-P015-5.0	S6-L-P015-10.0	S6-L-P025-3.0	S6-L-P025-5.0	S6-L-P025-10.0

Model	Servo motor encoder cable					
	23-bit encoder (single turn)			23-bit encoder (multi-turn)		
	L = 3.0 m	L = 5.0 m	L = 10.0 m	L = 3.0 m	L = 5.0 m	L = 10.0 m
MS1H2	S6-L-P011-3.0	S6-L-P011-5.0	S6-L-P011-10.0	S6-L-P021-3.0	S6-L-P021-5.0	S6-L-P021-10.0
MS1H3 (1.8 kW & below)	S6-L-P011-3.0	S6-L-P011-5.0	S6-L-P011-10.0	S6-L-P021-3.0	S6-L-P021-5.0	S6-L-P021-10.0
MS1H3 (2.9 kW)	S6-L-P011-3.0	S6-L-P011-5.0	S6-L-P011-10.0	S6-L-P021-3.0	S6-L-P021-5.0	S6-L-P021-10.0
MS1H3 (above 2.9 kW)	S6-L-P011-3.0	S6-L-P011-5.0	S6-L-P011-10.0	S6-L-P021-3.0	S6-L-P021-5.0	S6-L-P021-10.0

Model	Connector kit	Battery set for absolute encoder back-up
MS1H2	S6-C2 (CN1 & CN2 terminal, 20-18 pin & 20-29 pin connector)	S6-C4 (battery & battery case)
MS1H3 (1.8 kW & below)	S6-C2 (CN1 & CN2 terminal, 20-18 pin & 20-29 pin connector)	
MS1H3 (2.9 kW)	S6-C3 (CN1 & CN2 terminal, 20-22 pin & 20-29 pin connector)	
MS1H3 (above 2.9 kW)		

## Appearance of cables

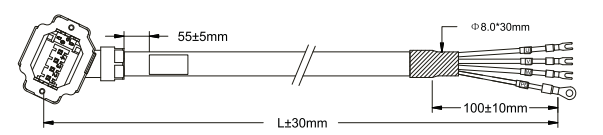
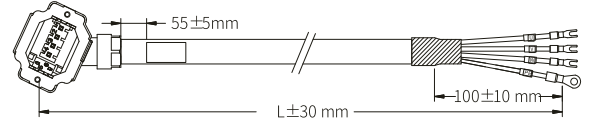
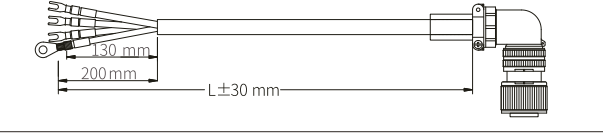
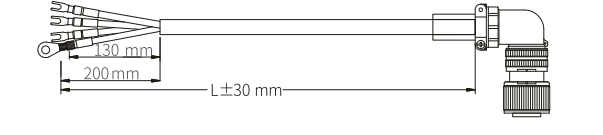
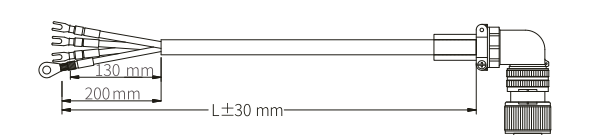
Cable type	Item code	L (mm)	Appearance
MS1H1/H4 motor power cable without brake (front outlet)	S6-L-M007-3.0	3,000	
	S6-L-M007-5.0	5,000	
	S6-L-M007-10.0	10,000	
MS1H1/H4 motor power cable without brake (back outlet)	S6-L-M008-3.0	3,000	
	S6-L-M008-5.0	5,000	
	S6-L-M008-10.0	10,000	
MS1H2/H3 motor power cable without brake	S6-L-M011-3.0	3,000	
	S6-L-M011-5.0	5,000	
	S6-L-M011-10.0	10,000	
MS1H3 motor power cable without brake	S6-L-M012-3.0	3,000	
	S6-L-M012-5.0	5,000	
	S6-L-M012-10.0	10,000	
MS1H3 motor power cable without brake	S6-L-M022-3.0	3,000	
	S6-L-M022-5.0	5,000	
	S6-L-M022-10.0	10,000	

# Appearance of cables

Cable type	Item code	L (mm)	Appearance
MS1H1/H4 motor power cable with brake (front outlet)	S6-L-B007-3.0	3,000	
	S6-L-B007-5.0	5,000	
	S6-L-B007-10.0	10,000	
MS1H1/H4 motor power cable with brake (back outlet)	S6-L-B008-3.0	3,000	
	S6-L-B008-5.0	5,000	
	S6-L-B008-10.0	10,000	
MS1H2/H3 motor power cable with brake	S6-L-B011-3.0	3,000	
	S6-L-B011-5.0	5,000	
	S6-L-B011-10.0	10,000	
MS1H3 motor power cable with brake	S6-L-B012-3.0	3,000	
	S6-L-B012-5.0	5,000	
	S6-L-B012-10.0	10,000	
MS1H3 motor power cable with brake	S6-L-B022-3.0	3,000	
	S6-L-B022-5.0	5,000	
	S6-L-B022-10.0	10,000	
MS1H1/H4 motor encoder cable (front outlet) for 23 bit encoder (single turn)	S6-L-P014-3.0	3,000	
	S6-L-P014-5.0	5,000	
	S6-L-P014-10.0	10,000	
MS1H1/H4 motor encoder cable (back outlet) for 23 bit encoder (single turn)	S6-L-P015-3.0	3,000	
	S6-L-P015-5.0	5,000	
	S6-L-P015-10.0	10,000	
MS1H2/H3 motor encoder cable for 23 bit encoder (single turn)	S6-L-P011-3.0	3,000	
	S6-L-P011-5.0	5,000	
	S6-L-P011-10.0	10,000	
MS1H1/H4 motor encoder cable (front outlet) for 23 bit encoder (multi-turn)	S6-L-P024-3.0	3,000	
	S6-L-P024-5.0	5,000	
	S6-L-P024-10.0	10,000	
MS1H1/H4 motor encoder cable (back outlet) for 23 bit encoder (multi-turn)	S6-L-P025-3.0	3,000	
	S6-L-P025-5.0	5,000	
	S6-L-P025-10.0	10,000	

Cable type	Item code	L (mm)	Appearance
MS1H2/H3 motor encoder cable for 23 bit encoder (multi-turn)	S6-L-P021-3.0	3,000	
	S6-L-P021-5.0	5,000	
	S6-L-P021-10.0	1,000	
IS620P servo drive to PC communication cable	S6-L-T00-3.0	3,000	
IS620P servo drive CAN and RS485 multi-axis communication cable	S6-L-T01-0.3	300	
PLC ↔ IS620P servo drive CAN & RS485 communication cable	S6-L-T02-2.0	2,000	
IS620P servo drive CAN & RS485 termination resistor	S6-L-T03-0.0		
IS620P servo drive analog output (CN5) cable	S5-L-A01-1.0	1,000	
IS620N servo drive EtherCAT communication cable	S6-L-T04-0.3	300	
	S6-L-T04-3.0	3,000	
IS620N servo drive to PC communication cable	S6N-L-T00-3.0	3,000	
Absolute encoder battery	S6-C4		
Switch cable when replacing old ISMH1/ISMH4 motors with new MS1H1/MS1H4 motors	S6-C23	500	
IS620 servo drive CN1 connector	S6-C8 (DB44)		

# IS620 servo drive and motor selection table

Power supply voltage	Motor frame size (mm)	Motor power (W)	Motor rated speed (RPM)	Motor rated torque (Nm)	Motor peak torque (Nm)	Motor brake	IS620 drive H x W x D (mm)	Motor model	IS620P pulse/analog drive	IS620N EtherCAT drive
Single-phase 220 V	40	50	3,000	0.16	0.56		160 x 50 x 173	MS1H1-05B30CB-A330Z-INT	IS620PS1R6I-INT	IS620NS1R6I-INT
		50		0.16	0.56	Brake		MS1H1-05B30CB-A332Z-INT		
		100		0.32	1.12			MS1H1-10B30CB-A330Z-INT		
		100		0.32	1.12	Brake		MS1H1-10B30CB-A332Z-INT		
	60	200		0.64	2.24			MS1H1-20B30CB-A331Z-INT		
		200		0.64	2.24	Brake		MS1H1-20B30CB-A334Z-INT		
		400		1.27	4.46			MS1H1-40B30CB-A331Z-INT		
		400		1.27	4.46	Brake		MS1H1-40B30CB-A334Z-INT		
	60	400		1.27	4.46			MS1H4-40B30CB-A331Z-INT		
		400		1.27	4.46	Brake		MS1H4-40B30CB-A334Z-INT		
		400		1.27	4.46			MS1H4-40B30CB-A331Z-INT		
		400		1.27	4.46	Brake		MS1H4-40B30CB-A334Z-INT		
Single-phase & Three-phase 220 V	80	550	3,000	1.75	6.13		160 x 50 x 173	MS1H1-55B30CB-A331Z-INT	IS620PS5R5I-INT	IS620NS5R5I-INT
		750		2.39	8.36			MS1H1-75B30CB-A331Z-INT		
		750		2.39	8.36	Brake		MS1H1-75B30CB-A334Z-INT		
		750		2.39	8.36			MS1H4-75B30CB-A331Z-INT		
		750		2.39	8.36	Brake		MS1H4-75B30CB-A334Z-INT		
		750		2.39	8.36	Brake		MS1H4-75B30CB-A334Z-INT		
Three-phase 220 V	130	850	1,500	5.39	13.5		160 x 90 x 183	MS1H3-85B15CB-A331Z-INT	IS620PS7R6I-INT	IS620NS7R6I-INT
		850		5.39	13.5	Brake		MS1H3-85B15CB-A334Z-INT		
		1,300		8.34	20.85			MS1H3-13B15CB-A331Z-INT		
		1,300		8.34	20.85	Brake		MS1H3-13B15CB-A334Z-INT		
Three-phase 220 V	80	1,000	3,000	3.18	11.1		160 x 90 x 183	MS1H1-10C30CB-A331Z-INT	IS620PS7R6I-INT	IS620NS7R6I-INT
		1,000		3.18	7.21			MS1H2-10C30CB-A331Z-INT		
		1,000		3.18	7.21	Brake		MS1H2-10C30CB-A334Z-INT		
		1,000		3.18	9.54			MS1H2-10C30CB-A331Z-INT		
	1,000	3.18		9.54	Brake	MS1H2-10C30CB-A334Z-INT				
	1,500	4.9		12.70		MS1H2-15C30CB-A331Z-INT				
	1,500	4.9		12.70	Brake	MS1H2-15C30CB-A334Z-INT				
	1,500	4.9		12.70	Brake	MS1H2-15C30CB-A334Z-INT				

Power supply voltage	Motor frame size (mm)	Motor power (W)	Motor rated speed (RPM)	Motor rated torque (Nm)	Motor peak torque (Nm)	Motor brake	IS620 drive H x W x D (mm)	Motor model	IS620P pulse/analog drive	IS620N EtherCAT drive
Three-phase 400 V	130	850	1,500	5.39	13.5		160 x 90 x 183	MS1H3-85B15CD-A331Z-INT	IS620PT3R5I-INT	IS620NT3R5I-INT
		850		5.39	13.5	Brake		MS1H3-85B15CD-A334Z-INT		
		1,300		8.34	20.85			MS1H3-13C15CD-A331Z-INT		
		1,300		8.34	20.85	Brake		MS1H3-13C15CD-A334Z-INT		
		1,800		11.5	28.75			MS1H3-18C15CD-A331Z-INT		
		1,800		11.5	28.75	Brake		MS1H3-18C15CD-A334Z-INT		
	180	2,900		18.6	37.2			MS1H3-29C15CD-A331Z-INT		
		2,900		18.6	37.2	Brake		MS1H3-29C15CD-A334Z-INT		
		4,400		28.4	71.1			MS1H3-44C15CD-A331Z-INT		
		4,400		28.4	71.1	Brake		MS1H3-44C15CD-A334Z-INT		
		5,500		35	87.6			MS1H3-55C15CD-A331Z-INT		
		5,500		35	87.6	Brake		MS1H3-55C15CD-A334Z-INT		
	250	7,500		48	119			MS1H3-75C15CD-A331Z-INT		
		7,500		48	119	Brake		MS1H3-75C15CD-A334Z-INT		
		1,000		3.18	9.54			MS1H2-10C30CD-A331Z-INT		
		1,000		3.18	9.54	Brake		MS1H2-10C30CD-A334Z-INT		
		1,500		4.9	14.7			MS1H2-15C30CD-A331Z-INT		
		1,500		4.9	14.7	Brake		MS1H2-15C30CD-A334Z-INT		
Three-phase 400 V	100	2,000	3,000	6.36	19.1		160 x 90 x 183	MS1H2-20C30CD-A331Z-INT	IS620PT5R4I-INT	IS620NT5R4I-INT
		2,000		6.36	19.1	Brake		MS1H2-20C30CD-A334Z-S4-INT		
		2,500		7.96	23.90			MS1H2-25C30CD-A331Z-INT		
		2,500		7.96	23.90	Brake		MS1H2-25C30CD-A334Z-S4-INT		
		130		3,000	9.8	29.4			MS1H2-30C30CD-A331Z-INT	
				3,000	9.8	29.4		Brake	MS1H2-30C30CD-A334Z-S4-INT	
	4,000			12.6	37.8			MS1H2-40C30CD-A331Z-INT		
	4,000			12.6	37.8	Brake		MS1H2-40C30CD-A334Z-S4-INT		
	5,000			15.8	47.6			MS1H2-50C30CD-A331Z-INT		
	5,000			15.8	47.6	Brake		MS1H2-50C30CD-A334Z-S4-INT		



# Driven by Technology

☒☒☒☒☒☒☒☒



☒☒☒☒☒☒☒☒☒☒☒☒



☒☒☒☒☒☒☒☒



☒☒☒☒☒☒☒☒☒☒☒☒☒☒☒☒☒☒



☒☒☒☒☒☒☒☒☒☒☒☒☒☒☒☒☒☒

EtherCAT<sup>®</sup>



☒☒☒☒☒☒☒☒☒☒☒☒☒☒☒☒☒☒



☒☒☒☒☒☒☒☒



☒☒☒☒☒☒☒☒☒☒☒☒☒☒☒☒☒☒

EtherCAT<sup>®</sup>



☒☒☒☒☒☒☒☒☒☒☒☒☒☒☒☒☒☒

