

SV820 Multi-Axes Servo Drive

For high performance and high precision automated machines

- Single/ three phase supply voltage: 200-240 V
- Single & dual axes modules: 2.8-4.6 A
- Common power supply module: 1 kW-2 kW
- SV820 is designed to work seamlessly with the MS1 - a compact IP67 servo motor



The SV820 servo drive

The SV820 is a multi-axes servo platform, available in 3 or 4 axes versions, with a common power supply module. The drive features an ultra-fast control loop regulator and high dynamic response. SV820 is the result of a joint development project between Inovance's European and global R&D centres. The high performance servo offering has built-in safety and offers simple commissioning and maintenance in an efficient, compact package that is designed for robustness and reliability in harsh environments. SV820 is suited for demanding applications, such as SCARA robots, CNC and packaging, across a variety of industries including the mobile phone, semiconductor, touchscreen and LED manufacturing industries.

Easy commissioning and maintenance

- Built-in LED keypad
- Simple installation procedure requires only three screws
- Rapid, easy wiring due to removable connectors and spring-type connector terminals
- Fault isolation avoids chain reactions
- Built-in shorting device servomotor windings
- Simple fan replacement (with no tools required)
- Front or back outlet cables supported (same motor uses different cable fittings)
- Skilled engineers not required for set-up
- Fewer external components required (e.g. no external brake relay)
- Multiple axes in the same network segment can be commissioned simultaneously
- Torque compensation
- Adaptive notch filter
- Additional filter for low resonance suppression (elastic load)
- InoDriveStudio:
 - Software package designed for easy set-up

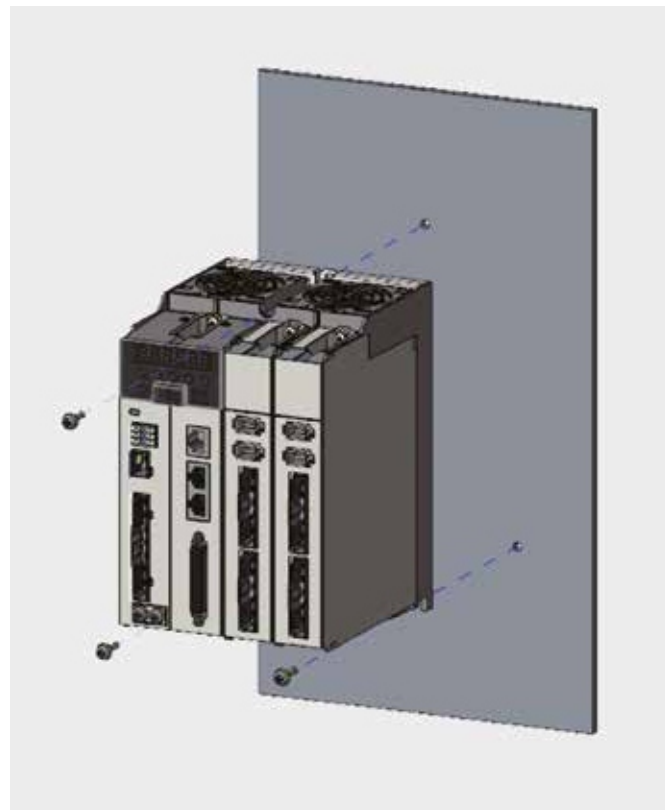

High performance

- Ultra-fast current loop bandwidth: >4 kHz
- Fast speed loop bandwidth: >2.5 kHz
- 350% maximum peak torque
- 23-bit absolute encoder
- Advanced vibration suppression function improves performance with elastic load
- Improved efficiency with load sharing between axes on the common DC bus

Onboard safety

- Dual input Safe Torque Off (STO) function (SIL3, PL e)
- CE certified
- The STO version (also known as the FS variant) is the default model of SV820

The STO function disables all axes at the same time. A variant without STO is also available.

Robust and reliable for harsh environments

- Class 2 conformal coating (as defined in IPC-A-610F); resistant to 3C2 and 3S2 environments (acc. to IEC 60721-3-3)
- Isolated cooling channels prevent dust contamination of internal electrical components
- Fully compatible with the IP67-rated MS1 motor
- The FH variant of SV820 is particularly strongly protected against harsh environments with enhanced conformal coating and an IP55-rated fan

Compact size

SV820 - the palm-sized, flexible drive



With SV820, a common DC supply means the drive footprint is reduced by up to 50% compared with the single axis IS620 drive



The SV820 servo drive

Product overview

MS1 motor features:

- 0.16-3.2 N·m
- Easy motor and encoder connections
- 23-bit motor encoder feedback (+/- 15 arcsec)
- 350% maximum peak current
- Motor torque ripple: <0.5%
- IP67 rated

Digital I/Os
24 digital inputs (16 fast & 8 standard) + 6 digital outputs
Power supply range
Single or three phase supply voltage - 200-240 V (-15% + 10%)
Network
EtherCAT – CiA 402 motion profile
Ethernet Modbus TCP/IP
Ethernet IP
Smart tuning
Inertia auto-tuning
Automatic loop gain
Adaptive notch filter
Automatic/manual damping filter for low frequency resonance suppression
Motors supported
Rotative servo motors
3 or 4 axes versions available
SV820 is available in 3 or 4 axes versions with a common power supply

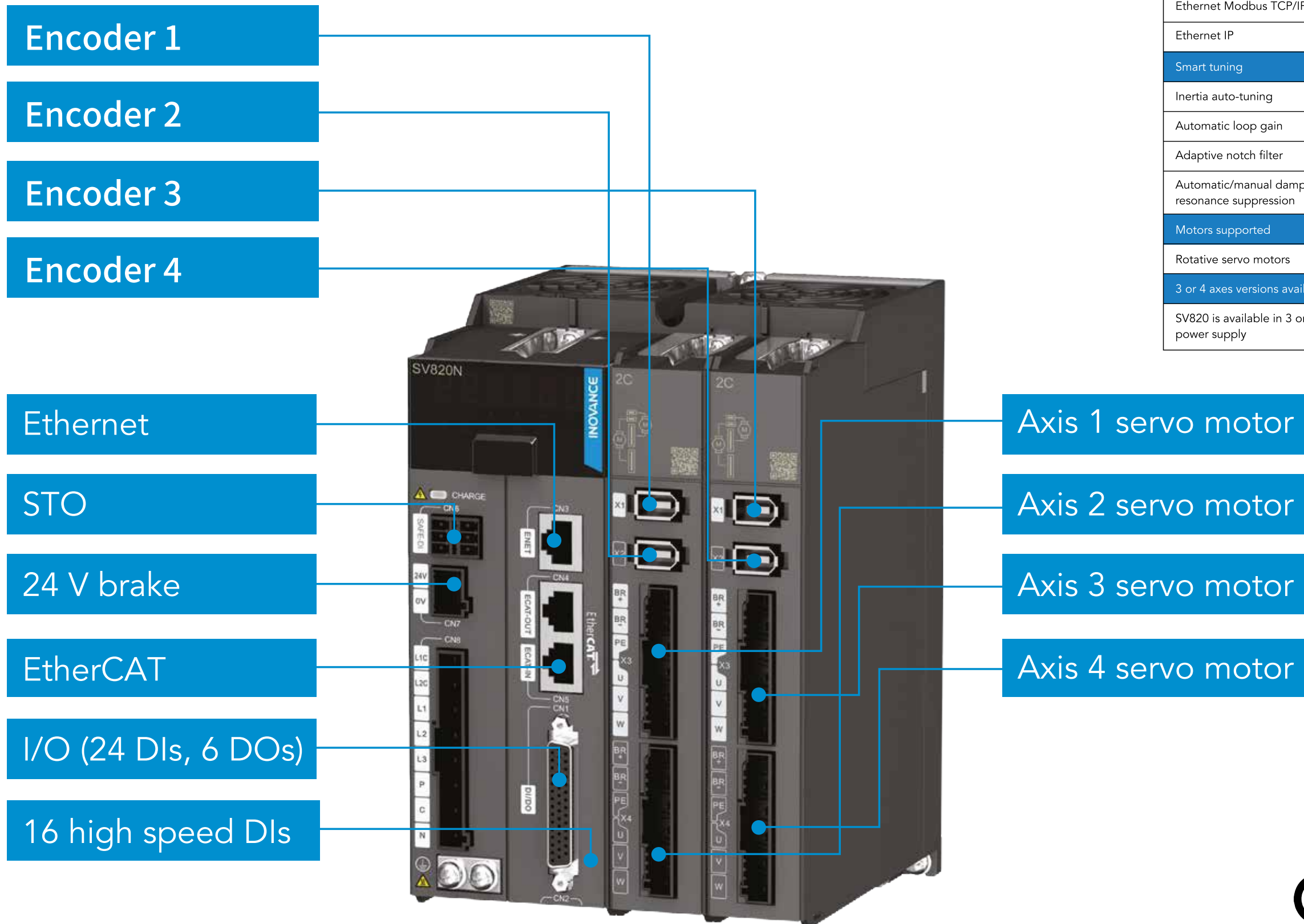

Application examples

The SV820 has been designed to suit the most demanding modern manufacturing applications such as SCARA robots, CNC, packaging, automated warehouse manipulators, and sorting and labelling machines.

SCARA robot solution

SCARA robot product benefits

Easy installation and wiring

Skilled engineers are not required for installation because the SV820 features modularized units and plug and play terminals. Additionally, system cables can be manufactured in advance to reduce wiring errors.

Fewer components required

In an SV820 system solution with a common DC supply, only one braking resistor is required per SCARA controller. Additionally, no external mechanical brake relay is required; and built-in digital I/O can be used as bus I/O to reduce system costs.

Rapid response

A maximum torque output of 350% plus high speed loop bandwidth of 3.0 kHz ensures that the Takt time of a 400 mm SCARA arm is 0.4 s, while for a 600 mm SCARA arm it is 0.5 s.

High reliability

The built-in dynamic brake can stop a SCARA robot within 80 ms when needed (e.g. when a servo error occurs). Quick and precise positioning is enabled by advanced algorithms which suppress resonance caused by high speed robot movement. Meanwhile, spring-type connector terminals enhance shock-proof performance.

Designed to work with the MS1 servo motor

The MS1 motor series has been designed with SCARA robots in mind, and meets mandatory requirements for motor installation dimensions for SCARA robot applications.

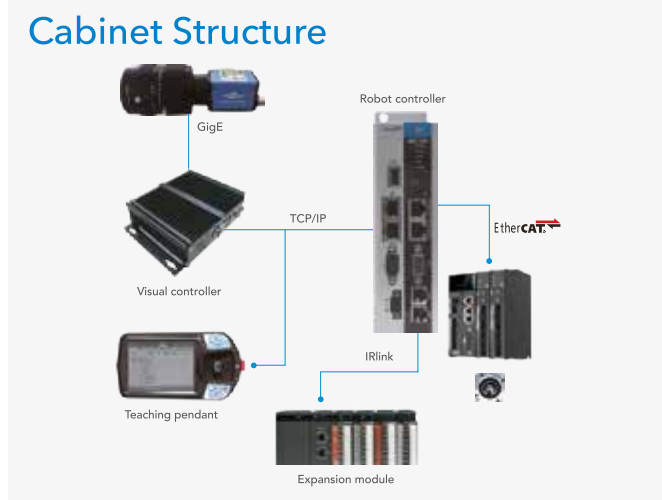
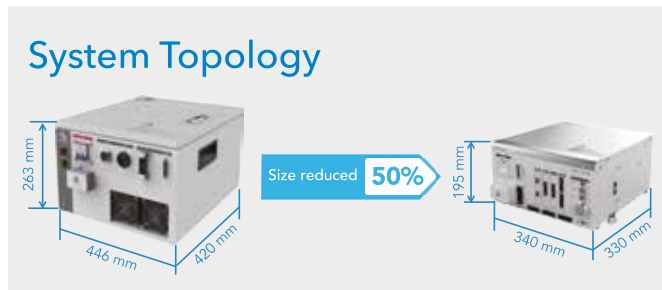

Simple system configuration and wiring

CNC system configuration is simplified, and complex operations (such as homing after power-up) are eliminated through the use of a 23-bit absolute encoder, reducing the required number of machine overtravel switches. Additionally, system powering is also simplified and wiring efficiency improved because SV820's built-in brake relay means the Z axis brake relay is eliminated.

Easy maintenance

The SV820's modular design allows for rapid fan replacement without removing the drive from the machine. Fault isolation for power supply and drive units avoids fault chain reactions, and each unit can be easily maintained simply by removing two screws.

Example laser cutting machine architecture



Packaging machine solution

Packaging product benefits

Compact size

SV820's common DC supply reduces drive footprint by up to 50% compared with the single axis IS620. The availability of dual-axes modules further reduces overall machine size, and combining the power supply unit with two dual-axes modules results in a single 4-axes unit of only 122 mm width.

High performance

Packaging machinery often requires a combination of low power alongside high speed and high performance. SV820 is ideally suited to these requirements due to the ultra-high performance of its 2.8-4.6 A single or dual axes modules, its single or three phase supply voltage of 200-240 V, and its power supply unit which ranges from 1-2 kW.

Safety

SV820's high safety standards are ideal for the high safety requirements of packaging machines, particularly cutting applications. The drive has CE certification, as well as a dual input Safe Torque Off (STO) function (SIL3).

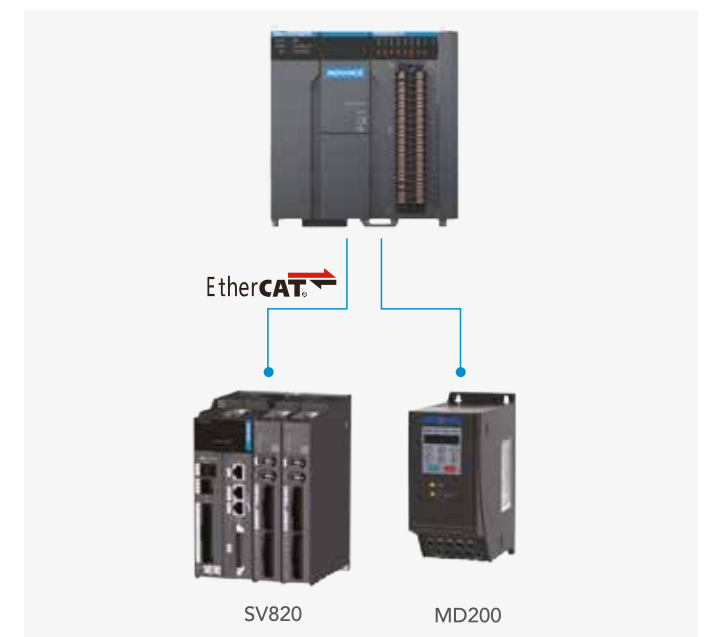

CNC solution

SV820 has a specialised high protection model - the FH variant, designed specifically for CNC applications

CNC product benefits

Robust and reliable

Isolated cooling channels reduce contamination of internal electrical components. Additionally, conformal coating offers an even higher layer of protection to PCB components. Meanwhile, the SV820's sister servo motor - the MS1 - is IP67-rated and has simple, 2-step connector terminals.

PC software tools

InoDriveStudio

InoDriveStudio is a PC-based software offering based on a familiar Windows™ interface. InoDriveStudio has adaptive adjustment for vibration free performance across a wide load inertia, and features a variety of other functions:

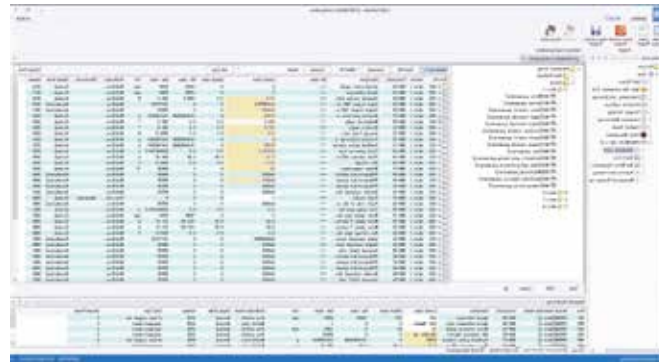

Upload parameters from the drive

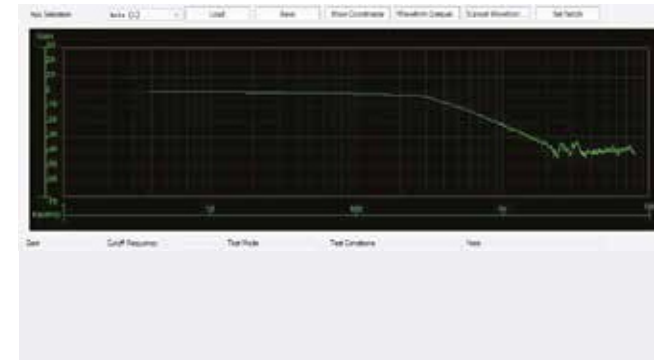

Mechanical analysis

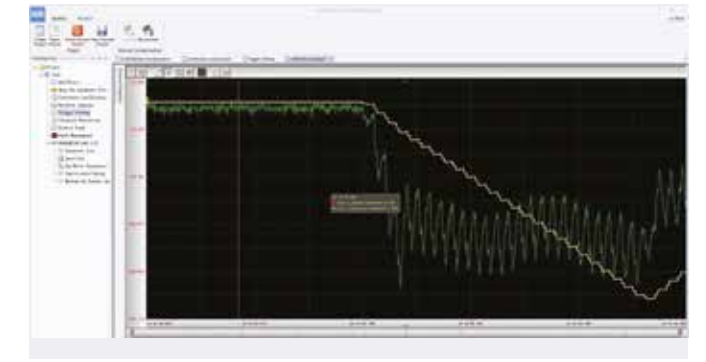

Trigger scope mode

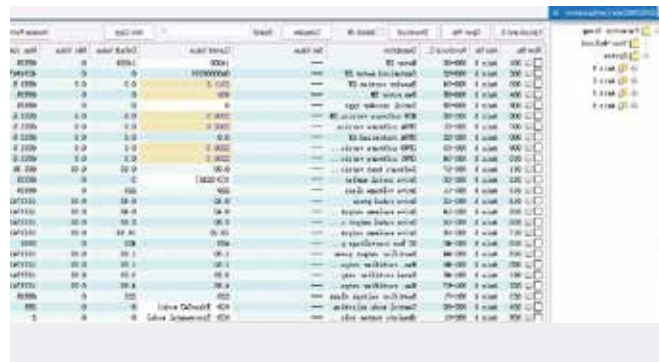

Parameter monitoring

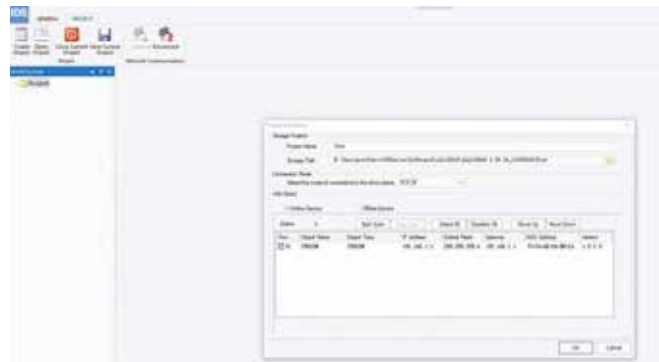

Auto drive discovery

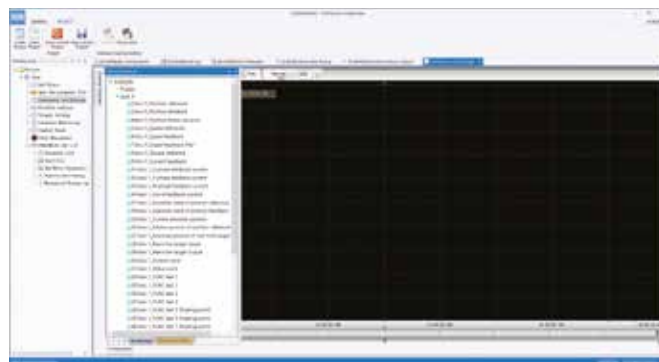

Scope channel settings



Waveform analyser (FFT)

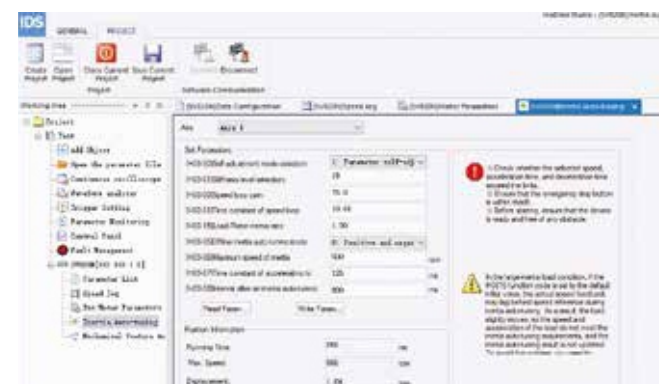

Inertia auto-tuning

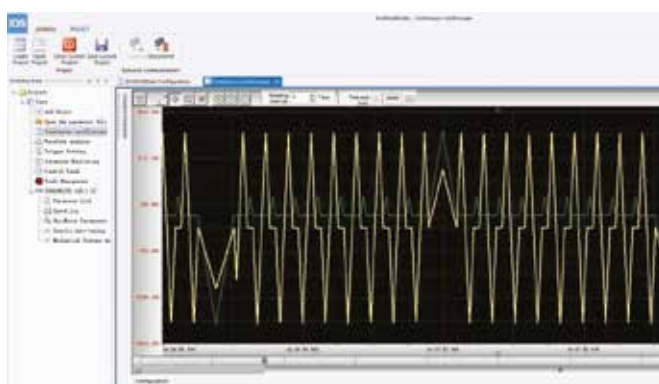

Continuous scope trace

SV820 servo drive technical data

Product ordering code

SV820 - N 1S 2C 2C FS

① ② ③ ④ ⑤ ⑥

- ① **Drive series:**
SV820 series
- ② **Control board type:**
N: EtherCAT
- ③ **Power supply unit type:**
1S: 1 kW
2S: 2 kW
- ④ **Drive unit 1**
Dual axes drive unit (rated current per axis)
2C: 2.8 A (400 W)
2D: 4.6 A (750 W)
- ⑤ **Drive unit 2**
Single axis drive unit (rated current)
1C: 2.8 A (400 W)
1D: 4.6 A (750 W)

Dual axes drive unit (rated current per axis)
2C: 2.8 A (400 W)
2D: 4.6 A (750 W)
- ⑥ **Variant**
Blank: No STO
FS: STO version (default variant)
FH: robust design for harsh environments

Please confirm specific models with Inovance's sales personnel before ordering.

MS1 H1 - 40B 30C B - A3 3 1 Z

① ② ③ ④ ⑤ ⑥ ⑦ ⑧ ⑨

- ① **Motor series:**
MS1 series
- ② **Type:**
H1: low inertia, small capacity
H4: medium inertia, small capacity
- ③ **Rated power (W)**
Comprised of a letter and a number
A: x1
B: x10
C: x100
D: x1000
E: x10000
e.g. 40B: 400 W
- ④ **Rated speed (rpm)**
Comprised of a letter and a number
A: x1
B: x10
C: x100
D: x1000
E: x10000
e.g. 30C: 3000 rpm
- ⑤ **Voltage rating**
B: 220 V
- ⑥ **Encoder type**
Comprised of a letter and a number
A3: 23 bit multi-turn absolute encoder
U3: 23 bit single-turn absolute encoder
- ⑦ **Shaft type**
1: Plain shaft
2: Solid and keyed
3: Oil sealed, and tapped holes
5: Solid and tapped holes
- ⑧ **Brake and oil sealing**
0: None
1: Oil sealing
2: Brake
4: Oil sealing + brake
- ⑨ **Motor specification**
Z: Z series motor

SV820 servo drive specifications

EtherCAT Drive Model	Axes	Input Power 220 V AC	Rated Output Power of Power Supply Unit	Axis 1 Output Current	Axis 2 Output Current	Peak Output Current (3 s)	Axis 3 Output Current	Axis 4 Output Current	Peak Output Current (3 s)
Power supply unit				Drive unit 1			Drive unit 2		
SV820N2S2C2C	4 axes	Three phase	2 kW	2.8 A	2.8 A	8.4 A	2.8 A	2.8 A	8.4 A
SV820N2S2C2D	4 axes	Three phase	2 kW	2.8 A	2.8 A	8.4 A	4.6 A	4.6 A	13.8 A
SV820N1S2C1C	3 axes	Single/three phase	1 kW	2.8 A	2.8 A	8.4 A	2.8 A	-	8.4 A
SV820N2S2C1D	3 axes	Three phase	2 kW	2.8 A	2.8 A	8.4 A	4.6 A	-	13.8 A
SV820N2S2D1D	3 axes	Three phase	2 kW	4.6 A	4.6 A	13.8 A	4.6 A	-	13.8 A

2.8 A axis controls up to 400 Watt motors
4.6 A axis controls up to 750 Watt motors

Product dimensions

Single and dual axes drive unit dimensions

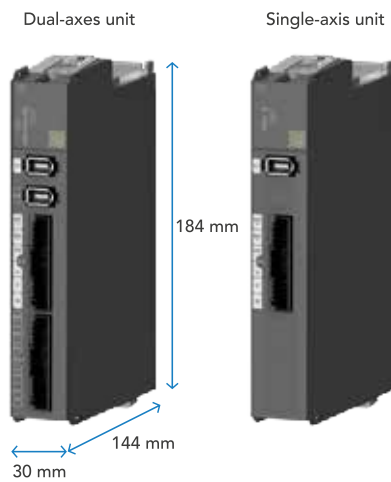

Power supply unit dimensions

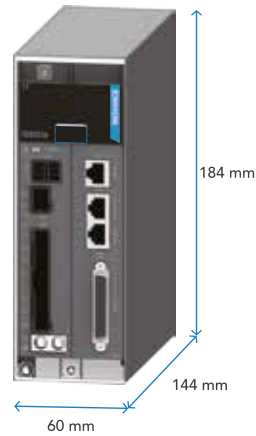

4 axes unit dimensions

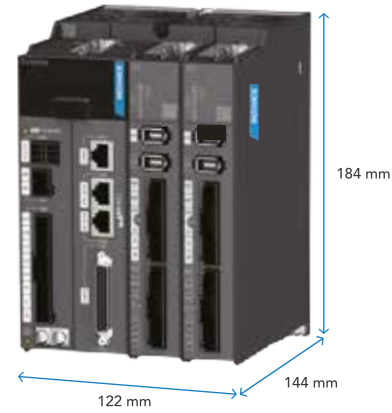

Please note: there is a 1 mm gap between each module in the 4 axes unit.

Optional extras

Connection cable kits

Usage	Item	Type Code (static PVC)	Type Code (flexible PVC)	Length (m)	
Terminal type (z) motor cables (front outlet)	Main circuit cable (without brake)	S6-L-M107-3.0	S6-L-M107-3.0-TS	3.0	
		S6-L-M107-5.0	S6-L-M107-5.0-TS	5.0	
		S6-L-M107-10.0	S6-L-M107-10.0-TS	10.0	
	Main circuit cable (with brake)	S6-L-B107-3.0	S6-L-B107-3.0-TS	3.0	
		S6-L-B107-5.0	S6-L-B107-5.0-TS	5.0	
		S6-L-B107-10.0	S6-L-B107-10.0-TS	10.0	
	Absolute encoder cable	S6-L-P124-3.0	S6-L-P124-3.0-T	3.0	
		S6-L-P124-5.0	S6-L-P124-5.0-T	5.0	
	Terminal type (z) motor cables (back outlet)	Motor power cable (without brake)	S6-L-M108-3.0	S6-L-M108-3.0-TS	3.0
			S6-L-M108-5.0	S6-L-M108-5.0-TS	5.0
S6-L-M108-10.0			S6-L-M108-10.0-TS	10.0	
Motor power cable (with brake)		S6-L-B108-3.0	S6-L-B108-3.0-TS	3.0	
		S6-L-B108-5.0	S6-L-B108-5.0-TS	5.0	
		S6-L-B108-10.0	S6-L-B108-10.0-TS	10.0	
Absolute encoder cable		S6-L-P125-3.0	S6-L-P125-3.0-T	3.0	
		S6-L-P125-5.0	S6-L-P125-5.0-T	5.0	
Communication cable for multi-drive parallel connection		Incremental encoder cable	S6-L-P114-3.0	S6-L-P114-3.0-T	3.0
			S6-L-P114-5.0	S6-L-P114-5.0-T	5.0
	S6-L-P114-10.0		S6-L-P114-10.0-T	10.0	
	Communication cable for multi-drive parallel connection	S6-L-T04-0.2		0.2	
		S6-L-T04-0.3		0.3	
		S6-L-T04-0.5		0.5	
		S6-L-T04-1.0		1.0	
		S6-L-T04-2.0		2.0	
		S6-L-T04-3.0		3.0	
		S6-L-T04-5.0		5.0	
S6-L-T04-10.0		10.0			

Connector kits

Item	Connector kit model
SV820 I/O connector kit	S6-C8 (DB44 connector kit for servo drive I/O connection)
SV820 battery	SV82-C4 (encoder back-up battery box kit)
MS1 motor connectors	S6-C21 (connector kit for servo motor cables without brake)
	S6-C22 (connector kit for servo motor cables with brake)

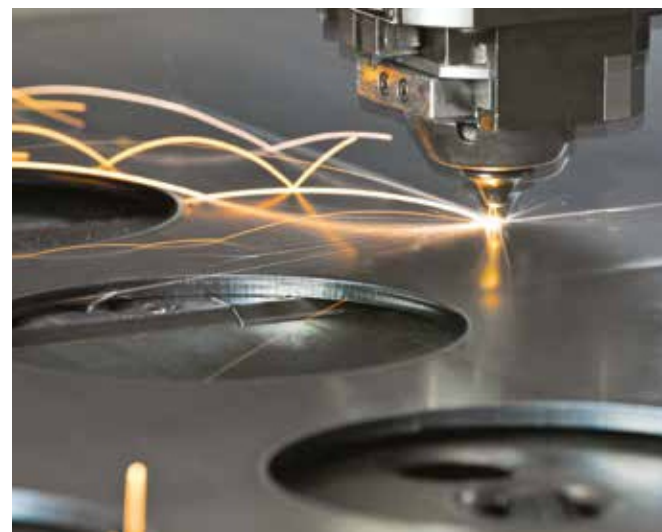

MS1 motor specifications

Motor Type	Rated Output (kW)	Rated Torque (N·m)	Maximum Torque (N·m)	Rated Current (Arms)	Maximum Current (Arms)	Rated Speed (rpm)	Maximum Speed (rpm)	Torque Constant (N·m/Arms)	Rotor Inertia Moment (10 ⁻⁴ kg·m ²)	Voltage (V)
Low inertia										
MS1H1-05B30CB	0.05	0.16	0.56	1.3	4.7	3000	6000	0.15	0.026	220
									0.028	
MS1H1-10B30CB	0.1	0.32	1.12	1.3	4.7				0.041	
									0.043	
MS1H1-20B30CB	0.2	0.64	2.24	1.5	5.8				0.207	
						0.22				
MS1H1-40B30CB	0.4	1.27	4.46	2.8	10.1			0.376		
								0.39		
Medium inertia										
MS1H1-55B30CB	0.55	1.75	6.13	3.8	15	3000	6000	0.49	1.06	220
									1.38	
MS1H1-75B30CB	0.75	2.39	8.36	4.8	16.9				1.43	
									1.75	
MS1H4-40B30CB	0.4	1.27	4.46	2.8	10.1				0.657	
						0.667				
MS1H4-75B30CB	0.75	2.39	8.36	4.8	16.9			2		
								2.012		

Servo motor dimensions and drawings

MS1H1 / MS1H4 mounting dimensions (N_{rated} = 3,000 rpm, N_{max} = 6,000 rpm)

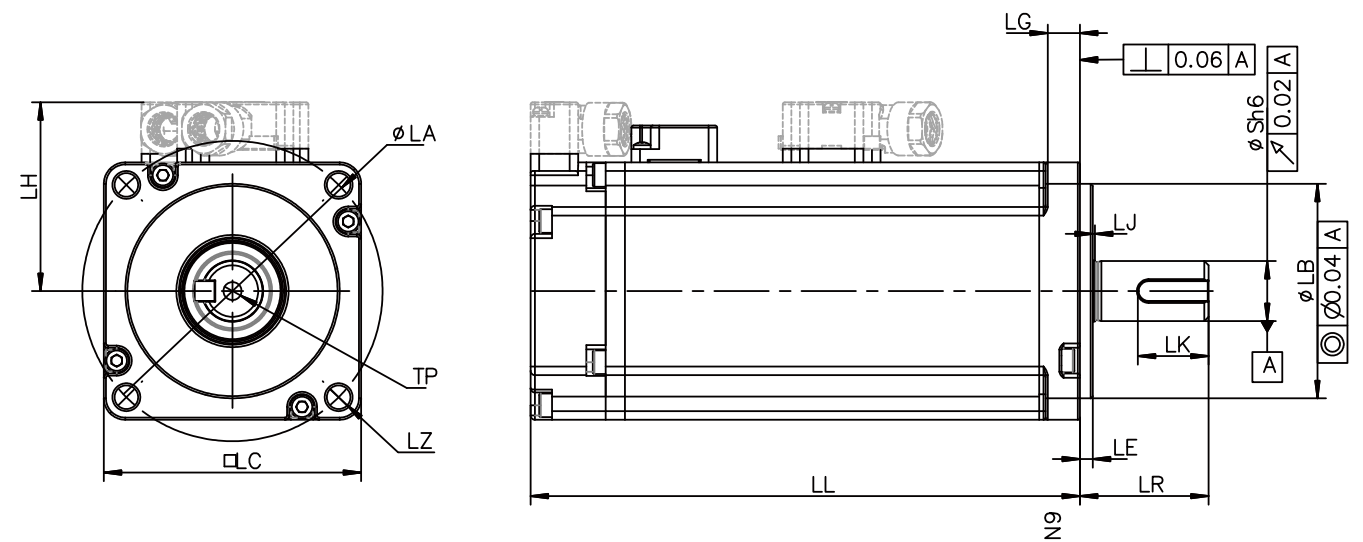

Model	LC (mm)	LL (mm)	LR (mm)	LA (mm)	LZ (mm)	LH (mm)	LG (mm)	LE (mm)
MS1H1-05B30CB-xxxxZ-INT	40	65 (96)	25±0.5	46	2-Ø4.5	34	5	2.5±0.5
MS1H1-10B30CB-xxxxZ-INT	40	77.5 (109)	25±0.5	46	2-Ø4.5	34	5	2.5±0.5
MS1H1-20B30CB-xxxxZ-INT	60	72.5 (100)	30±0.5	70	4-Ø5.5	44	7.5	3±0.5
MS1H1-40B30CB-xxxxZ-INT	60	91 (119)	30±0.5	70	4-Ø5.5	44	7.5	3±0.5
MS1H1-55B30CB-xx31Z-INT	80	96.2	35±0.5	90	4-Ø7	54	7.7	3±0.5
MS1H1-75B30CB-xxxxZ-INT	80	107 (140)	35±0.5	90	4-Ø7	54	7.7	3±0.5
MS1H4-40B30CB-xxxxZ-INT	60	105 (128)	30±0.5	70	4-Ø5.5	44	7.5	3±0.3
MS1H4-70B30CB-xxxxZ-INT	60	117.5 (147.5)	30±0.5	90	4-Ø7	54	7.7	3±0.3

Model	LJ (mm)	LB (mm)	S (mm)	TP (mm)	LK (mm)	KH (mm)	T (mm)	Weight (kg)
MS1H1-05B30CB-xxxxZ-INT	0.5±0.35	30	8	M3 X 6	15.5	6.2	3	0.39 (0.50)
MS1H1-10B30CB-xxxxZ-INT	0.5±0.35	30	8	M3 X 6	15.5	6.2	3	0.45 (0.64)
MS1H1-20B30CB-xxxxZ-INT	0.5±0.35	50	14	M5 X 8	16.5	11.0	5	0.78 (1.16)
MS1H1-40B30CB-xxxxZ-INT	0.5±0.35	50	14	M5 X 8	16.5	11.0	5	1.11 (1.48)
MS1H1-55B30CB-xx31Z-INT	0.5±0.35	70	19	M6 X 20	25	15.5	6	1.85
MS1H1-75B30CB-xxxxZ-INT	0.5±0.35	70	19	M6 X 20	25	15.5	6	2.18 (2.82)
MS1H4-40B30CB-xxxxZ-INT	0.5±0.35	50	14	M5 X 8	16.5	11.0	5	1.27 (1.62)
MS1H4-70B30CB-xxxxZ-INT	0.5±0.35	70	19	M6 X 20	25	15.5	6	2.40 (3.04)