

User Guide

AM403 Series PLC (NPN)



Suzhou Inovance Technology Co.,Ltd

Address: No.16 Youxiang Road, Yuexi, Wuzhong District, Suzhou 215104

Customer service hotline: 4000-300124

Website: <http://www.inovance.com>



Technical support APP



Document Download



19011278A00

Thank you for purchasing the AM400 series PLC developed and manufactured independently by Inovance.

The AM400 series PLC is a CoDeSys-based medium-sized PLC, which fully supports the IEC61131-3 programming system, real-time EtherCAT fieldbus, and cam synchronous motion control. It has a unique high-speed IO port adapted for high-speed applications.

This guide mainly describes the specifications, characteristics, and usage of the AM400 series PLC. Read this guide carefully before using to fully understand the product and ensure safety. Visit our website (www.inovance.com) for the latest version of the guide.

1 Safety Instructions

1.1 Safety Precautions

1. Before installing, using, and maintaining this equipment, read the safety information and precautions thoroughly, and comply with them during operations.
2. To ensure the safety of humans and equipment, follow the signs on the equipment and all the safety instructions in this user guide.
3. The “CAUTION”, “WARNING” and “DANGER” signs are only supplements to the safety instructions.
4. Use this equipment according to the designated environment requirements. Damage caused by improper usage is not covered by warranty.
5. Inovance shall take no responsibility for any personal injuries or property damage caused by improper usage.

1.2 Safety Levels and Definitions

 **Warning**: Indicates that failure to comply with the notice may result in severe personal injuries or even death.

 **Caution**: The “CAUTION” sign indicates that failure to comply with the notice may result in minor or moderate personal injury or damage to the equipment.

Keep this guide well so that it can be read when necessary and forward this guide to the end user.

During control system design



- ◆ Provide a safety circuit outside the PLC so that the control system can still work safely once external power failure or PLC fault occurs.
- ◆ Add a fuse or circuit breaker because the module may smoke or catch fire due to long-time overcurrent caused by operation above rated current or load short-circuit.



- ◆ An emergency stop circuit, a protection circuit, a forward/reverse operation interlocked circuit, and an upper position limit and lower position limit interlocked circuit must be set in the external circuits of PLC to prevent damage to the machine.
- ◆ To ensure safe operation, for the output signals that may cause critical accidents, design external protection circuit and safety mechanism;
- ◆ Once PLC CPU detects abnormality in the system, all outputs may be closed; however, when a fault occurs in the controller circuit, the output may not be under control. Therefore, it is necessary to design an appropriate external control circuit to ensure normal operation;
- ◆ If the PLC output units such as relays or transistors are damaged, the output may fail to switch between ON and OFF states according to the commands;
- ◆ The PLC is designed to be used in indoor electrical environment (overvoltage category II). The power supply must have a system-level lightning protection device, assuring that overvoltage due to lightning shock cannot be applied to the PLC power supply input terminals, signal input terminals and output terminals and so forth, so as to avoid damage to the equipment.

Installation



- ◆ Installation must be carried out by the specialists who have received the necessary electrical training and understood enough electrical knowledge.
- ◆ Disconnect all external power supplies of the system before removing/installing the module. Failure to do so may result in electric shock, module fault or malfunction.
- ◆ Do not use the PLC where there are dust, oil smoke, conductive dust, corrosive or combustible gases, or exposed to high temperature, condensation, wind & rain, or subject to vibration and impact. Electric shock, fire and malfunction may also result in damage or deterioration to the product.
- ◆ The PLC is open-type equipment that must be installed in a control cabinet with lock (cabinet housing protection > IP20). Only the personnel who have received the necessary electrical training and understood enough electrical knowledge can open the cabinet.



Caution

- ◆ Prevent metal filings and wire ends from dropping into The ventilation holes of the PLC during installation. Otherwise it may result in fire, fault and malfunction.
- ◆ Ensure there are no foreign matters on ventilation surface. Failure to comply may result in poor ventilation, which may cause fire, fault and malfunction.
- ◆ Ensure the module is connected to the respective connector securely and hook the module firmly. Improper installation may result in malfunction, fault or fall-off.

Wiring



Warning

- ◆ Wiring must be carried out by personnel who have received the necessary electrical training and understood enough electrical knowledge.
- ◆ Disconnect all external power supplies of the system before wiring. Failure to comply may result in electric shock, module fault or malfunction.
- ◆ Install the terminal cover attached to the product before power-on or operation after wiring is completed. Failure to comply may result in electric shock
- ◆ Perform good insulation on terminals so that insulation distance between cables will not reduce after cables are connected to terminals. Failure to comply may result in electric shock or damage to the equipment.



Caution

- ◆ Prevent dropping metal filings and wire ends drop into ventilation holes of the PLC at wiring. Failure to comply may result in fire, fault and malfunction.
- ◆ The external wiring specification and installation method must comply with local regulations. For details, see the wiring section in this guide.
- ◆ To ensure safety of equipment and operator, use cables with sufficient diameter and connect the cables to ground reliably.
- ◆ Ensure that all cables are connected to the correct interface. Failure to comply may result in module and external equipment fault.
- ◆ Tighten bolts on the terminal block in the specified torque range. If the terminal is not tight, short-circuit, fire or malfunction may be caused. If the terminal is too tight, fall-off, short-circuit, fire or malfunction may be caused.
- ◆ If the connector is used to connect with external equipment, perform correct crimping or welding with the tool specified by manufacturer. If connection is in poor contact, short-circuit, fire or malfunction may be caused.
- ◆ A label on the top of the module is to prevent foreign matters entering the module. Do not remove the label during wiring. Remember to remove it before system operation, facilitating ventilation.
- ◆ Do not bundle control wires, communication wires and power cables together. They must be run with distance of more than 100 mm. Otherwise, noise may result in malfunction.
- ◆ Select shielded cable for high-frequency signal input/output in applications with serious interference so as to enhance system anti-interference ability.

Operation and Maintenance



- ◆ Maintenance & inspection must be carried out by personnel who have the necessary electrical training and experience.
- ◆ Do not touch the terminals while the power is on. Failure to comply may result in electric shock or malfunction.
- ◆ Disconnect all external power supplies of the system before cleaning the module or re-tightening screws on the terminal block or screws of the connector. Failure to comply may result in electric shock.
- ◆ Disconnect all external power supplies of the system before removing the module or connecting/removing the communication wirings. Failure to comply may result in electric shock or malfunction.



- ◆ Get with the guide and ensure safety before online modification, forcible output, and RUN/STOP operation.
- ◆ Disconnect the power supply before installing/removing the extension card.

Disposal



- ◆ Treat scrapped module as industrial waste. Dispose the battery according to local laws and regulations.

2 Product Information

2.1 Model Number and Nameplate

AM403-CPU1608TN

Product Information		Series		Module Type		HS I/O Points		Output Mode	
M	Medium-sized PLC Automation-Motion	2 RS485, 1 LAN, 1 CANopen/ CANlink, EtherCAT bus		CPU	CPU module	16	16 inputs	TN	Sink output
						16	8 outputs		



Model	Category	Description
AM403-CPU1608TN	CPU module	10 M program storage space; 20 M data storage space; 2 RS485 ports, 1 CANopen/CANlink port, and 1 LAN port; Support for EtherCAT bus; built-in 16-in-8-out high-speed I/O; supports up to 16 DSP402 slaves; sink-type output.

2.2 External Interface

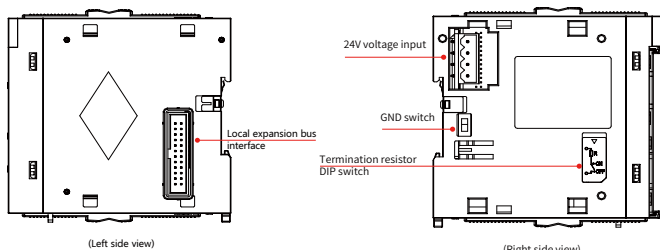
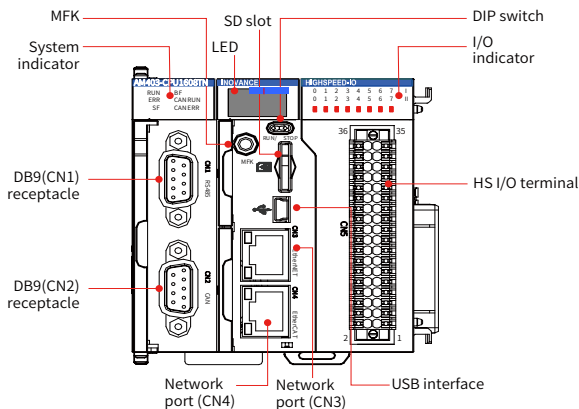
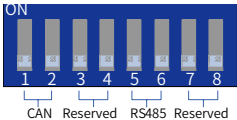

Figure 1 Diagram of CPU module interfaces

Interface Name	Function
DB9 (CN1)/(receptacle)	2 RS485 ports, supporting MODBUS protocol
DB9 (CN2)/(receptacle)	1 CANopen/CANlink port
Network port (CN4)	EtherCAT protocol
Network port (CN3)	<ol style="list-style-type: none"> 1. MODBUS TCP protocol 2. Standard Ethernet functions 3. System program commissioning 4. User program download and commissioning (IPv4 only)

Interface Name	Function	
USB	Program download and commissioning	
High-speed IO	16-point high-speed input 8-point high-speed output	
I/O indicator	Indicates the signal effectiveness of all I/Os	
DIP switch	RUN/STOP DIP switch	
SD card interface	Stores user programs and user data	
MFK key	Multi-functional key	
Indicator	Operation indicator (RUN)	
	CPU module error indicator (ERR)	
	System error indicator (SF)	
	Bus error indicator (BF)	
LED display	Displays alarm information, and information for the MFK key	
Local expansion bus interface	Supports up to 16 local modules. The actual number and configuration depend on each module's power consumption. Hot plugging is not supported	
24 V power input terminal	DC 24 V voltage input, used with an AM600 power module	
Grounding switch	For system digital GND and housing GND. Not used by default. To ensure system stability, it should be only used when the digital GND is used as a reference plane.	
Termination resistor DIP switch	ON means a resistor is connected (the default is OFF); 1 and 2 are for CAN, 3, 4, 7 and 8 are reserved, and 5 and 6 are for COM0 (RS485):	

2.3 General Specifications

Item	Specifications
Programming method	IEC 61131-3 programming languages (LD, FBD, IL, ST, SFC, CFC)
Program execution mode	Compile and run
User program storage space	10 MB
Flash space for power failure memory	512 KB

Item	Specifications
SD card capacity	Up to 32 G
Program power failure memory	Flash or SD card retention (only available when power is on for more than 35s before going out)
Internal 5 V power output current	1500 mA (rated value)
Interrupt mode	8-point input interrupt (CPU module high-speed DI), supports rising edge and falling edge interrupts

■ Input specification

Item	Specifications		
Signal Name	High-speed input (differential or single-ended) (X0–X3)		High-speed input (single-ended) (X4–XF)
	24 V input	Differential input	24 V input
Rated input voltage	24 VDC (-15% to +20%, rippling within 5%)	EIA RS-422-A compliant differential line drive level (equivalent to AM26LS31)	24 VDC (-15% to +20%, rippling within 5%)
Rated input current	7.3 mA@24 VDC (typical)		7.3 mA (typical) (@24 VDC)
ON current	More than 5 mA		More than 5 mA
OFF current	Less than 1.5 mA		Less than 1.5 mA
Input resistance	3.3 kΩ		3.3 kΩ
Max. counting speed	800 Kpps (two-phase quadruplicated frequency), 200 kHz (single input)		
Least ideal duty cycle of 2-phase input	(40%: 60%)–(60%: 40%)		
Common terminal	Each point has a separate common terminal	--	5 points share 1 common terminal

■ Output

Item	Specifications
Signal Name	Output (Y0–Y7)
Output polarity	Sink

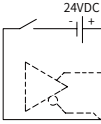
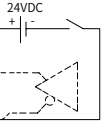
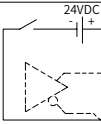
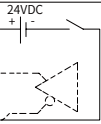
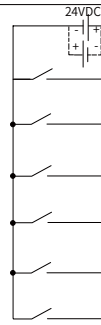
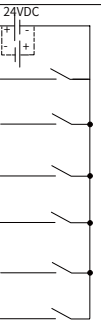
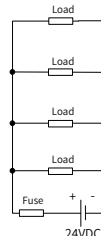
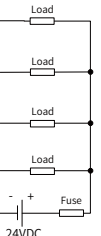
Ext. Wiring	Signal Name		CN5 pin. No.	Signal Name		Ext. Wiring
	Column B	Column A		Column B	Column A	
	HS 24V input (Xn0-24V)	36	35	HS 24V input (Xn2-24V)		
	HS DIFF input (Xn0-DIFF)	34	33	HS DIFF input (Xn2-DIFF)		
	HS input COM (Xn0-COM)	32	31	HS input COM (Xn2-COM)		
	HS 24V input (Xn1-24V)	30	29	HS 24V input (Xn3-24V)		
	HS DIFF input (Xn1-DIFF)	28	27	HS DIFF input (Xn3-DIFF)		
	HS input COM (Xn1-COM)	26	25	HS input COM (Xn3-COM)		
	Input COM (SS0)	24	23	Input COM (SS1)		
	Standard input (I4)	22	21	Standard input (I5)		
	Standard input (I6)	20	19	Standard input (I7)		
	Standard input (I8)	18	17	Standard input (I9)		
	Standard input (I1A)	16	15	Standard input (I1B)		
	Standard input (I1C)	14	13	Standard input (I1D)		
	Standard input (I1E)	12	11	Standard input (I1F)		
	Output (Q0)	10	9	Output (Q1)		
	Output (Q2)	8	7	Output (Q3)		
	Output (Q4)	6	5	Output (Q5)		
	Output (Q6)	4	3	Output (Q7)		
	Output COM (COM0)	2	1	Output COM (COM1)		

* 1 The CPU module provides 16 high-speed inputs. The first 4 support 24 V single-ended input or 5 V differential input, and the other 12 support 24 V single-ended input.

* 2 For specific wiring methods and wiring examples, please contact Inovance for a High-Speed I/O Wiring User Guide.

Equivalent internal circuit:

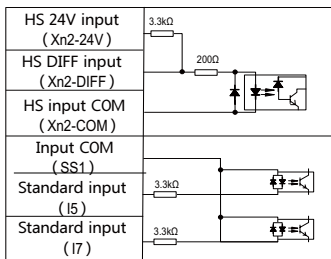

* 1 For 24 V single-ended signals, Xn-24V and Xn-COM are used;

* 2 For 5 V differential signals, Xn- DIFF and Xn-COM are used.

3.2 Wiring Precautions

- 1) The total length of the high-speed I/O cables should be within 3.0 m.
- 2) Do not bundle the extension cable together with power cables (high voltage, large current) which produce strong interference signals. Separate it from other cables and avoid cabling in parallel.
- 3) Select recommended cables and pinboards for connection. It is recommended that shielded cables be used as extension cables to enhance capacity of resisting interference.
- 4) When laying the extension cable, make sure that the minimum bending radius of the cable is more than 76 mm. When the bending radius is 76 mm, malfunction may occur due to poor performance or disconnection.

Application example

The first 6 DIs support high-speed single-ended and differential signals. You must pay special attention during wiring. The following table is an application example where Xn0 is used.

Example	Wiring				
	Input Type	Ext. Wiring	No.	Signal Name	Int. Circuit
(1) PNP 24 V level input	PNP collector (24V level)		36	HS 24V input (Xn0-24V)	
			34	HS DIFF input (Xn0-DIFF)	
			32	HS input COM (Xn0-COM)	

Example		Wiring			
Input Type	Ext. Wiring	No.	Signal Name	Int. Circuit	
(2) NPN 24 V level input		36	HS 24V input (Xn0-24V)		
		34	HS DIFF input (Xn0-DIFF)		
		32	HS input COM (Xn0-COM)		
(3) Differential 5 V level input		36	HS 24V input (Xn0-24V)		
		34	HS DIFF input (Xn0-DIFF)		
		32	HSinput COM (Xn0-COM)		

4 Mechanical Design Reference

4.1 Dimensions

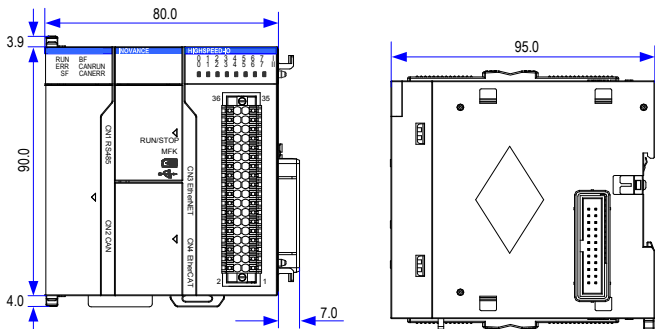

Figure 3 Dimensions of CPU module (in mm)

5 Communication Connection

5.1 Cabling of CPU module and communication module

1) RJ45 cable connection

- Insert the cable connector into the RJ45 port of the communication module until you hear a click sound.

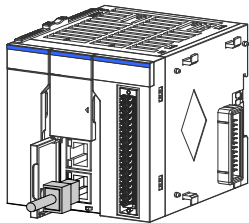

Figure 4 Cable connection diagram

- Removal: press the release tab of the connector to pull out the connector and module horizontally.
- 2) Requirements for securing communication cable

To protect the communication cable from any tension and to ensure communication stability, fix the cable end which is near the device before communication, as shown below:

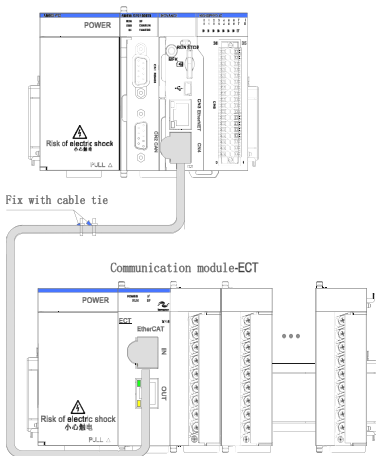

Figure 5 Fix the cable end that near the device

5.2 EtherCAT bus connection

1) EtherCAT Bus Specifications

Item	Specifications
Communication protocol	EtherCAT protocol
Service supported	CoE (PDO, SDO)
Max. synchronous jitter	120 us (typical)
Synchronization mode	The servo adopts a DC-distributed clock and input and output synchronization
Physical layer	100BASE-TX
Baud rate	100 Mbit/s (100Base-TX)
Duplex mode	Full duplex
Topology	Linear
Transmission medium	Network cables, see the Wiring section
Transmission distance	Less than 100 m between two nodes
Number of slaves	Up to 16 DSP402 slaves

EtherCAT frame length	44–1498 bytes
Process data	Max. 1486 bytes per Ethernet frame

2) Wiring

The CPU module provides a CN4 port for EtherCAT bus communication. An ECT communication network cable that meets the following requirements is a must:

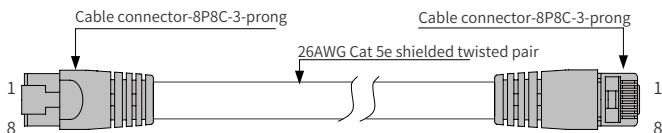

Figure 6 Requirements on the EtherCAT cable

■ Signal pins

Pin	Signal	Signal Direction	Signal Description
1	TD+	Output	Data transmission+
2	TD-	Output	Data transmission-
3	RD+	Input	Data reception+
4	--	--	Not used
5	--	--	Not used
6	RD-	Input	Data reception-
7	--	--	Not used
8	--	--	Not used

■ Length requirements:

According to FastEthernet technology, when an EtherCAT bus is used, the length of the cable between the devices must not exceed 100 meters. Exceeding this length will attenuate the signal and affect communication.

■ Technical requirements:

100% continuity test, no short circuit, open circuit, misalignment and poor contact. It is recommended to use the following cables:

Item	Specifications
Cable type	Flexible crossover cable, S-FTP, Cat 5e
Complied standards:	EIA/TIA568A, EN50173, ISO/IEC11801 EIA/TI Abulletin TSB, EIA/TIA SB40-A&TSB36
Conductor type	Twisted pair
Pair	4

5.3 Connection through CANopen/CANlink bus

1) Networking diagram

CAN bus topology is shown below. Using shielded twisted cables to connect CAN bus is recommended. Two 120 Ω termination resistors are attached to both ends of the bus to prevent signal reflection. Single-point grounding is used for the shield.

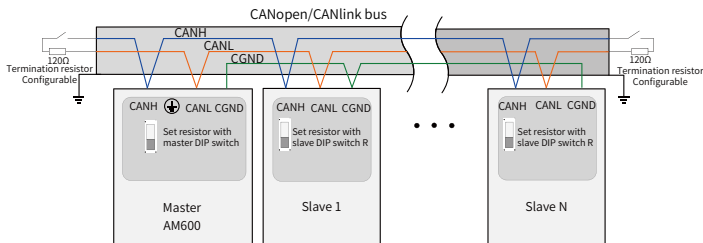

Figure 7 CANopen/CANlink communication connection

2) Communication interfaces

The CPU module provides a CN2 terminal for CANopen communication and a DB9 connector for data transmission.

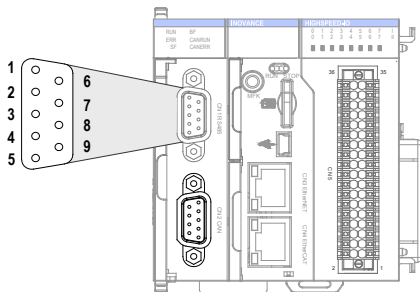

Figure 9 RS485 communication terminal on CPU module

Pin definition:

Channel	Pin	Definition	Function
COM0 (RS485)	1	RS485-	COM0 RS485 differential pair negative signal
	2	RS485+	COM0 RS485 differential pair positive signal
	5	GND0	COM0 power GND
COM1 (RS485)	6	RS485-	COM1 RS485 differential pair negative signal
	9	RS485+	COM1 RS485 differential pair positive signal
	3	GND1	COM1 power GND

5.5 Ethernet Connection for Monitoring

1) Networking diagram

With the Ethernet port, the CPU module can be connected point-to-point with devices such as a computer and HMI through an Ethernet cable:

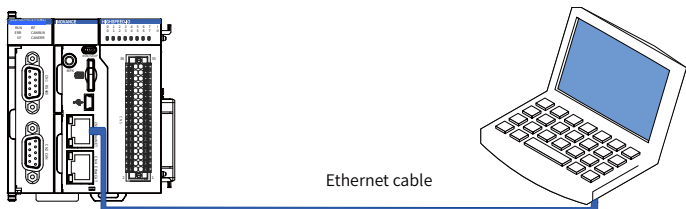

Figure 10 Connection between CPU module and PC

The CPU module can also be connected to a hub or switch, which is further connected with other network devices, through an Ethernet cable to achieve multi-point connection.

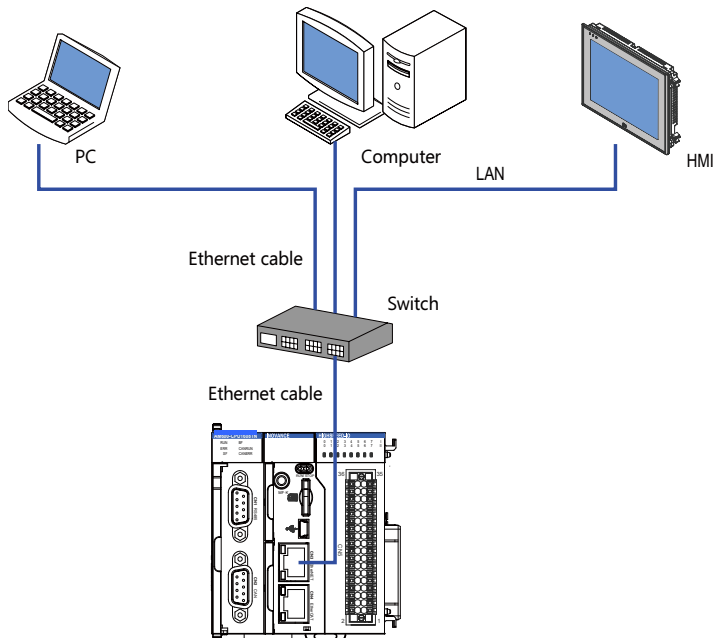

Figure 11 Connection between CPU module and other devices through a switch

2) Wiring

To improve communication reliability, the Ethernet cable must be injection-molded Cat5 shielded twisted pair and with an injection molded and iron shelled connector.

6 Programming Tool

6.1 Programming tool download

Inovance provides InoProShop as the user programming tool for AM403 medium-sized PLCs. It is free and you can obtain a DVD copy from our distributors or download it from our website www.inovance.com, where you can also download documents about AM403 PLC products and their applications.

Due to the continuous improvement of products and information by the

company, you are recommended to timely update the software and related documents.

6.2 Programming Environment and Software Installation

Hardware requirements: A desktop PC or a laptop running Windows XP or above, with 2 GB RAM and more than 5 GB free space on the hard disk or SSD. To ensure performance, the CPU frequency should be above 2 GHz.

The PC can be connected with the PLC through a LAN cable. It is recommended to use a router between the PC and PLC. That allows for longer distance and faster communication speed between them, and you can sit in your office and program the PLC running in the workshop, for example. Therefore, a free LAN network port in the local network and a network cable are required.

The PC can also be connected with the PLC through a USB cable. In this case, a USB cable with a MiniUSB connector is required.

7 Operation and Maintenance

7.1 Start and Stop

Start and stop the system in the following procedure.

To start the system after the CPU module is programmed in STOP state:

Switch to RUN

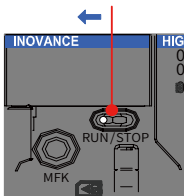

1. Set Set the RUN/STOP switch to the RUN position

2. Check that the RUN indicator is steady on and green

Switch to STOP

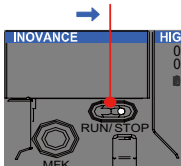

3. Set the RUN/STOP switch to the STOP position to stop the system. The system can also be stopped by the host computer.

8 Indicators and MFK Key

8.1 CPU module indicator

Name	Indication
RUN indicator	Indicates the status of the system (running or stopped). The indicator is on during operation and off when the system is stopped
ERR indicator	Indicates system failure
SF indicator	Expansion bus error indicator
BF indicator	Communication error indicator

8.2 MFK Key

The MFK key is mainly used to reset the IP address of the PLC main module. It is effective when the PLC is in STOP state.

The default IP address of the CPU module is 192.168.1.88. If you modify this address and forget the new address later, you will not be able to network the PLC with another PC. In that case, you can use the MFK key to restore the IP address of the CPU module to the default.

- 1) In the STOP state, press and hold the MFK key until the LED screen displays I.P., and then release the key;

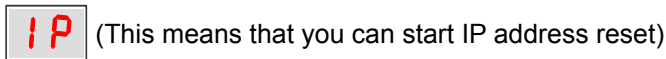

- 2) If you are sure to reset the IP address, press the MFK key again. The LED screen displays a countdown from 10 to 0.



- 3) Before the countdown reaches 0, you can press the MFK key to cancel the reset operation. After the IP address is reset, you must restart the PLC to enable the default address.

8.3 LED Display on CPU Module

When the system fails, “Er” and a fault code will be displayed alternately on

the LED display of the CPU module. For example, if the fault code is 40, the LED screen will display information as follows:









Fault information on LED screen and remedies:



CPU and I/O Module	Indication	Remedy
	No fault	-
	CPU model does not agree with software. Check that the PLC is authorized.	Contact your distributor
	CPU Local expansion bus error	Check the connection between local rack modules.
	Configuration error	Check that the configuration of the local rack module is consistent with that in the software.
	Module error	Check whether the local rack module reports a fault, and check the detailed fault information in the software.



High-Speed I/O	Indication	Remedy
	High-speed input error	Check the detailed fault information in the software.
	High-speed input alarm	Check the detailed fault information in the software.
	High-speed output error	Check the detailed fault information in the software.

	High-speed output alarm	Check the detailed fault information in the software.
--	-------------------------	---

ModBus	Indication	Remedy
	ModBus COM0 error	Check the detailed fault information in the software.
	ModBusTcp error	Check the detailed fault information in the software.

CANopen	Indication	Remedy
	Slave error	Check the connection between slave rack modules.
	Slave hardware configuration error	Check that the configuration of the slave rack module is consistent with that in the software.
	Slave module error	Check whether the slave rack module reports a fault, and check the detailed fault information in the software.
	CANopen master bus disabled	Check whether the CANopen function of the master is disabled or the CANopen communication of the master is abnormal.

CANlink	Indication	Remedy
	Bus error (BUS OFF)	Check bus connection. Check the detailed fault information in the software.
	Address conflict	Check the address configuration.

	(Master) no online slave	Check the connection of slaves and parameter setting.
	(Master) slave disconnected	Check the connection of slaves.
	Configuration or command frame error	Check bus configuration parameters.

9 Module Connection

9.1 Connection between Power Supply Module, CPU Module and Expansion Modules

The connection between the modules is mainly through the connection interfaces and latch of each module. The following example instructs how to connect the CPU module to the power module.

1. Slide the latch on the CPU module as shown in the figure.

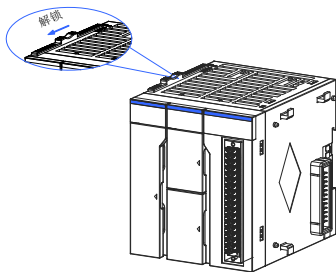

2. Fully connect the connector of the CPU module with the connector of the power supply module.

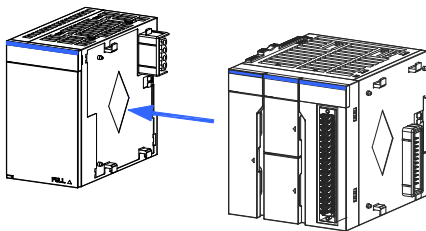

3. Slide the latch on the CPU module as shown in the figure.

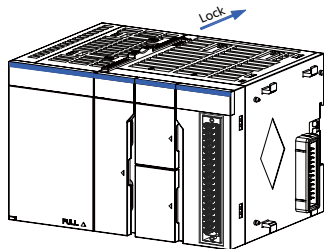

Note: After the I/O terminal block is mounted to CN5, fix it with a torque of $0.2\text{--}0.25\text{ N}\cdot\text{m}$, as shown in the following figure.

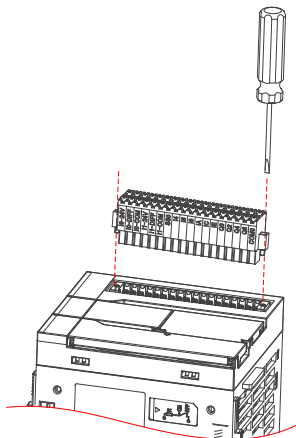

9.2 Connection between Power Supply Module, CPU Module and Expansion Modules

1. Pull down all the DIN rail mounting hooks on the back of the module (as shown in the following figure). Pull the hook until you hear a click sound.

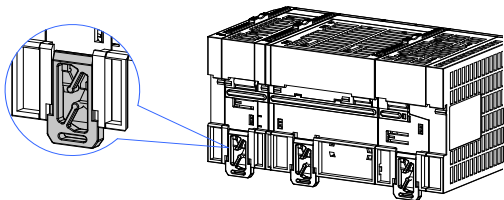

2. In direction A as shown in the following figure, hang the clasp on the upper part of the module onto the top of the DIN rail, and press the module assembly firmly in direction B until it fully engages with the guide rail.

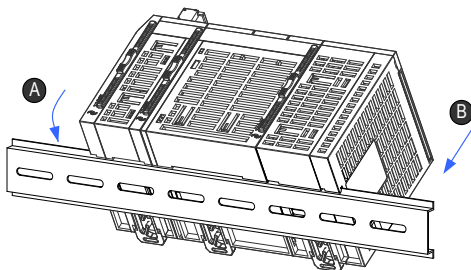

3. Push the DIN rail mounting hooks onto the DIN rail. Push the hook up until you hear a click sound. If your finger cannot reach the hook, use a screwdriver or the like.

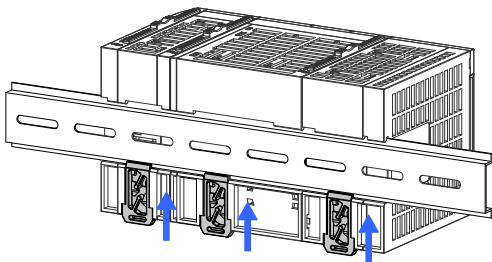

INOVANCE Warranty Agreement

Inovance provides an 18-month free warranty to the equipment itself from the date of manufacturing for the failure or damage under normal use conditions.

Within the warranty period, maintenance will be charged for the damage caused by the following reasons:

- 1) Improper use or repair/modification without prior permission
- 2) Fire, flood, abnormal voltage, natural disasters and secondary disasters
- 3) Hardware damage caused by dropping or transportation after procurement
- 4) Operations not following the user instructions
- 5) Damage out of the equipment (for example, external device factors)

The maintenance fee is charged according to the latest Maintenance Price List of Inovance.

If there is any problem during the service, contact Inovance's agent or Inovance directly.

Inovance reserves the rights for explanation of this agreement.