

# SV660P Series Servo Drive Hardware Guide



# Preface

## Overview

The SV660P series high-performance AC servo drive covers a power range from 50 W to 7.5 kW. It supports Modbus, CANopen and CANlink communication protocols and carries necessary communication interfaces to work with the host controller for a networked operation of multiple servo drives.

The SV660P servo drive supports adaptive stiffness level setting, inertia auto-tuning, and vibration suppression, which simplifies the operation process. It allows a quiet and stable operation and accurate positioning control together with an MS1 series high-response servo motor with small or medium inertia and a 23-bit single-turn or 23-bit multi-turn absolute encoder.

The SV660P series servo drive serves to achieve quick and accurate position control, speed control, and torque control in automation equipment such as electronic manufacturing devices, manipulators, packing devices, and machine tools.

This guide introduces installation and wiring of the servo drive, including preparations before installation, unpacking inspection and transportation, wiring, and routine maintenance.

## More Documents

Name	Data Code
SV660P series servo drive selection guide	19011390
SV660P series servo drive commissioning guide	19011392
SV660P series servo drive function guide	19011393

## Revision History

Date of Revision	Version	Revision
August 2020	A00	First release
November 2020	A01	Minor corrections
December 2020	A02	Updated the naming rules for the motor.
April 2021	A03	<ul style="list-style-type: none"> <li>• Updated the naming rules for the servo drive.</li> <li>• Updated the descriptions for cable models.</li> <li>• Updated the naming rules for cables.</li> <li>• Updated pin assignment of power cable connector terminal (motor side).</li> <li>• Added precautions for encoder signal wiring.</li> </ul>

## **Document Acquisition**

The guide is not delivered along with the product. You can download the PDF version from <http://en.inovance.cn/support/download.html>.

# Table of Contents

Preface .....	1
Fundamental Safety Instructions .....	6
1 Product Information .....	12
1.1 Nameplate and Model Number of the Servo Drive .....	12
1.2 Nameplate and Model Number of the Servo Motor .....	13
1.3 Model Number of Cables .....	14
1.4 Components .....	16
1.4.1 Servo Drives in Size A (Rated Power: 200 W to 400 W) .....	16
1.4.2 Servo Drives in Size B (Rated Power: 750 W) .....	18
1.4.3 Servo Drives in Size C and Size D (Rated Power: 1.0 kW to 3.0 kW) .....	20
1.4.4 Servo Drives in Size E (Rated Power: 5.0 kW to 7.5 kW) .....	24
1.4.5 Servo Motors in Flange Sizes 40/60/80 .....	25
1.4.6 Servo Motors in Flange Sizes 100/130/180 .....	27
2 Installation .....	28
2.1 Installing the Servo Drive .....	28
2.1.1 Unpacking Inspection .....	28
2.1.2 Installation Environment .....	30
2.1.3 Installation Clearance .....	31
2.1.4 Installation Dimensions .....	33
2.1.5 Installation Precautions .....	36
2.1.6 Installation Instructions .....	37
2.2 Installing the Servo Motor .....	38
2.2.1 Unpacking Inspection .....	38
2.2.2 Installation Environment .....	39
2.2.3 Installation Dimensions .....	40
2.2.4 Installation Precautions .....	50
2.3 Installing the Optional Parts .....	52
2.3.1 Instructions for the Installing Fuse and Circuit Breaker .....	52
2.3.2 Instructions for Installing the AC Input Reactor .....	53
2.3.3 Instructions for Installing the EMC Filter .....	53
2.3.4 Instructions for Installing Magnetic Ring and Ferrite Clamp .....	54
3 Wiring .....	56
3.1 Wiring Precautions .....	56
3.2 System Wiring Diagram .....	58
3.3 Wiring Diagram for Different Control Modes .....	64
3.3.1 Wiring Diagram for the Position Control Mode .....	64
3.3.2 Wiring Diagram for the Torque Control Mode .....	66
3.4 Terminal Layout of the Servo Drive .....	68

3.4.1	Main Circuit Terminal Pin Layout . . . . .	73
3.4.2	Description of Encoder Terminal (CN2) . . . . .	78
3.4.3	Description of the Control Terminal (CN1). . . . .	79
3.4.4	Description of Communication Terminals (CN3/CN4) . . . . .	82
3.5	Connecting the Power supply (RST) . . . . .	83
3.5.1	Wiring Precautions . . . . .	83
3.5.2	Main Circuit Wiring Requirements . . . . .	84
3.5.3	Recommended Cable Specifications and Models. . . . .	85
3.5.4	Wiring of the Power Supply . . . . .	89
3.5.5	Wiring of External EMC Filter . . . . .	92
3.5.6	Grounding and Wiring . . . . .	93
3.6	Connecting the Motor (UVW) . . . . .	98
3.7	Connecting the Encoder (CN2). . . . .	101
3.7.1	Installing the Absolute Encoder Battery Box . . . . .	101
3.7.2	Connecting the Absolute Encoder Cable . . . . .	105
3.7.3	Precautions for Encoder Signal Wiring. . . . .	109
3.8	Connecting the Control Signal (CN1) . . . . .	110
3.8.1	Wiring of I/O Signal Cables. . . . .	110
3.8.2	Position Reference Input Signals . . . . .	111
3.8.3	DI/DO Signals. . . . .	119
3.8.4	Encoder Frequency-Division Output Signals . . . . .	123
3.8.5	Wiring of the Brake . . . . .	125
3.9	Connecting the Communication Signals (CN3/CN4) . . . . .	128
3.9.1	CAN Communication Connection . . . . .	128
3.9.2	Wiring of RS485 Communication . . . . .	130
3.9.3	Wiring of RS232 Communication with PC . . . . .	133
3.10	Wiring and Setting of the Regenerative Resistor . . . . .	134
4	Maintenance. . . . .	141
4.1	Routine Maintenance . . . . .	141
4.1.1	Routine Checklist . . . . .	141
4.1.2	Routine Cleaning List . . . . .	141
4.2	Periodic Maintenance. . . . .	142
4.2.1	Periodic Checklist . . . . .	142
4.2.2	Periodic Maintenance List . . . . .	142
4.3	Parts Replacement . . . . .	143
4.3.1	Disassembling the Motor Flat Key. . . . .	143
4.3.2	Disassembling the Motor Oil Seal . . . . .	144
5	Appendix 1 Certifications and Standards Compliance . . . . .	146
5.1	Compliance List . . . . .	146
5.2	CE Certification . . . . .	146
5.2.1	Requirement for Compliance with EMC Directive. . . . .	147
5.2.2	Requirements for Compliance with LVD . . . . .	148

5.3	UL&cUL Certification .....	149
6	Appendix 2 Common EMC Problems and Solutions .....	153
6.1	Malfunction of the Residual Current Device (RCD) .....	153
6.2	Harmonic Suppression.....	154
6.3	Control Circuit Interference .....	154
6.3.1	High-speed Pulse Interference .....	154
6.3.2	I/O Signal Interference .....	155
6.4	RS485&CAN Communication Interference .....	156

# Fundamental Safety Instructions

## Safety Precautions

1. This chapter presents essential safety instructions for a proper use of the equipment. Before operating the equipment, read through the user guide and comprehend all the safety instructions. Failure to comply with the safety instructions may result in death, severe personal injuries, or equipment damage.
2. "CAUTION", "WARNING", and "DANGER" items in the user guide only indicate some of the precautions that need to be followed; they just supplement the safety precautions.
3. Use this equipment according to the designated environment requirements. Damage caused by improper use is not covered by warranty.
4. Inovance shall take no responsibility for any personal injuries or property damage caused by improper use.

## Safety Levels and Definitions



Indicates that failure to comply with the notice will result in death or severe personal injuries.



Indicates that failure to comply with the notice may result in death or severe personal injuries.



Indicates that failure to comply with the notice may result in minor or moderate personal injuries or equipment damage.

## General Safety Instructions

- Drawings in the user guide are sometimes shown without covers or protective guards. Remember to install the covers or protective guards as specified first, and then perform operations in accordance with the instructions.
- The drawings in the user guide are shown for illustration only and may be different from the product you purchased.

### Unpacking



- Do not install the equipment if you find damage, rust, or signs of use on the equipment or accessories upon unpacking.
- Do not install the equipment if you find water seepage or missing or damaged components upon unpacking.
- Do not install the equipment if you find the packing list does not conform to the equipment you received.

 CAUTION

- Check whether the packing is intact and whether there is damage, water seepage, dampness, and deformation before unpacking.
- Unpack the package by following the unpacking sequence. Do not strike the package violently.
- Check whether there is damage, rust, or injuries on the surface of the equipment and equipment accessories before unpacking.
- Check whether the package contents are consistent with the packing list before unpacking.

**Storage and Transportation** WARNING

- Large-scale or heavy equipment must be transported by qualified professionals using specialized hoisting equipment. Failure to comply may result in personal injuries or equipment damage.
- Before hoisting the equipment, ensure the equipment components such as the front cover and terminal blocks are secured firmly with screws. Loosely-connected components may fall off and result in personal injuries or equipment damage.
- Never stand or stay below the equipment when the equipment is being hoisted by the hoisting equipment.
- When hoisting the equipment with a steel rope, ensure the equipment is hoisted at a constant speed without suffering from vibration or shock. Do not turn the equipment over or let the equipment stay hanging in the air. Failure to comply may result in personal injuries or equipment damage.

 CAUTION

- Handle the equipment with care during transportation and mind your steps to prevent personal injuries or equipment damage.
- When carrying the equipment with bare hands, hold the equipment casing firmly with care to prevent parts from falling. Failure to comply may result in personal injuries.
- Store and transport the equipment based on the storage and transportation requirements. Failure to comply will result in equipment damage.
- Avoid storing or transporting the equipment in environments with water splash, rain, direct sunlight, strong electric field, strong magnetic field, and strong vibration.
- Avoid storing the equipment for more than three months. Long-term storage requires stricter protection and necessary inspections.
- Pack the equipment strictly before transportation. Use a sealed box for long-distance transportation.
- Never transport the equipment with other equipment or materials that may harm or have negative impacts on this equipment.

**Installation** DANGER

- The equipment must be operated only by professionals with electrical knowledge.



 WARNING

- Read through the user guide and safety instructions before installation.
- Do not install this equipment in places with strong electric or magnetic fields.
- Before installation, check that the mechanical strength of the installation site can bear the weight of the equipment. Failure to comply will result in mechanical hazards.
- Do not wear loose clothes or accessories during installation. Failure to comply may result in an electric shock.
- When installing the equipment in a closed environment (such as a cabinet or casing), use a cooling device (such as a fan or air conditioner) to cool the environment down to the required temperature. Failure to comply may result in equipment over-temperature or a fire.
- Do not retrofit the equipment.
- Do not fiddle with the bolts used to fix equipment components or the bolts marked in red.
- When the equipment is installed in a cabinet or final assembly, a fireproof enclosure providing both electrical and mechanical protections must be provided. The IP rating must meet IEC standards and local laws and regulations.
- Before installing devices with strong electromagnetic interference, such as a transformer, install a shielding device for the equipment to prevent malfunction.
- Install the equipment onto an incombustible object such as a metal. Keep the equipment away from combustible objects. Failure to comply will result in a fire.

 CAUTION

- Cover the top of the equipment with a piece of cloth or paper during installation. This is to prevent unwanted objects such as metal shavings, oil, and water from falling into the equipment and causing faults. After installation, remove the cloth or paper on the top of the equipment to prevent over-temperature caused by poor ventilation due to blocked ventilation holes.
- Resonance may occur when the equipment operating at a constant speed executes variable speed operations. In this case, install the vibration-proof rubber under the motor frame or use the vibration suppression function to reduce resonance.

**Wiring**

 DANGER

- Equipment installation, wiring, maintenance, inspection, or parts replacement must be performed only by professionals.
- Before wiring, cut off all the power supplies of the equipment, and wait for at least the time designated on the equipment warning label before further operations because residual voltage still exists after power-off. After waiting for the designated time, measure the DC voltage in the main circuit to ensure the DC voltage is within the safe voltage range. Failure to comply will result in an electric shock.
- Do not perform wiring, remove the equipment cover, or touch the circuit board with power ON. Failure to comply will result in an electric shock.
- Check that the equipment is grounded properly. Failure to comply will result in an electric shock.

 WARNING

- Do not connect the input power supply to the output end of the equipment. Failure to comply will result in equipment damage or even a fire.
- When connecting a drive to the motor, check that the phase sequences of the drive and motor terminals are consistent to prevent reverse motor rotation.
- Cables used for wiring must meet cross sectional area and shielding requirements. The shield of the cable must be reliably grounded at one end.
- Fix the terminal screws with the tightening torque specified in the user guide. Improper tightening torque may overheat or damage the connecting part, resulting in a fire.
- After wiring is done, check that all cables are connected properly, with no screws, washers, or exposed cables left inside the equipment. Failure to comply may result in an electric shock or equipment damage.

 CAUTION

- During wiring, follow the proper electrostatic discharge (ESD) procedure, and wear an antistatic wrist strap. Failure to comply will damage the equipment or the internal circuits of the equipment.
- Use shielded twisted pairs for the control circuit. Connect the shield to the grounding terminal of the equipment for grounding purpose. Failure to comply will result in equipment malfunction.

**Power-on** DANGER

- Before power-on, check that the equipment is installed properly with reliable wiring and the motor can be restarted.
- Check that the power supply meets equipment requirements before power-on to prevent equipment damage or a fire.
- After power-on, do not open the cabinet door or protective cover of the equipment, touch any terminal, or disassemble any unit or component of the equipment. Failure to comply will result in an electric shock.

 WARNING

- Perform a trial run after wiring and parameter setting to ensure the equipment operates safely. Failure to comply may result in personal injuries or equipment damage.
- Before power-on, check that the rated voltage of the equipment is consistent with that of the power supply. Failure to comply may result in a fire.
- Before power-on, check that no one is near the equipment, motor, or machine. Failure to comply may result in death or personal injuries.

**Operation** DANGER

- The equipment must be operated only by professionals. Failure to comply will result in death or personal injuries.
- Do not touch any connecting terminals or disassemble any unit or component of the equipment during operation. Failure to comply will result in an electric shock.

 WARNING

- Do not touch the equipment casing, fan, or resistor with bare hands to feel the temperature. Failure to comply may result in personal injuries.
- Prevent metal or other objects from falling into the equipment during operation. Failure to comply may result in a fire or equipment damage.

**Maintenance**

 DANGER

- Equipment installation, wiring, maintenance, inspection, or parts replacement must be performed only by professionals.
- Do not maintain the equipment with power ON. Failure to comply will result in an electric shock.
- Before maintenance, cut off all the power supplies of the equipment and wait for at least the time designated on the equipment warning label.
- In case of a permanent magnet motor, do not touch the motor terminals immediately after power-off because the motor terminals will generate induced voltage during rotation even after the equipment power supply is off. Failure to comply will result in an electric shock.

 WARNING

- Perform routine and periodic inspection and maintenance on the equipment according to maintenance requirements and keep a maintenance record.

**Repair**

 DANGER

- Equipment installation, wiring, maintenance, inspection, or parts replacement must be performed only by professionals.
- Do not repair the equipment with power ON. Failure to comply will result in an electric shock.
- Before inspection and repair, cut off all the power supplies of the equipment and wait for at least the time designated on the equipment warning label.

 WARNING

- When the fuse is blown or the circuit breaker or earth leakage current breaker (ELCB) trips, wait for at least the time designated on the equipment warning label before power-on or further operations. Failure to comply may result in death, personal injuries, or equipment damage.
- When the equipment is faulty or damaged, the troubleshooting and repair work must be performed by professionals that follow the repair instructions, with repair records kept properly.
- Replace quick-wear parts of the equipment according to the replacement instructions.
- Do not use damaged equipment. Failure to comply may result in death, personal injuries, or severe equipment damage.
- After the equipment is replaced, check the wiring and set parameters again.

**Disposal****WARNING**

- Dispose of retired equipment in accordance with local regulations and standards. Failure to comply may result in property damage, personal injuries, or even death.
- Recycle retired equipment by observing industry waste disposal standards to avoid environmental pollution.

**Safety Labels**

For safe equipment operation and maintenance, comply with the safety labels on the equipment. Do not damage or remove the safety labels. See the following table for descriptions of the safety labels.

Safety Label	Description
A black rectangular safety label containing four icons: a yellow triangle with a black exclamation mark, a white book icon, a yellow lightning bolt, and a white circular arrow with '10min' next to it.	<ul style="list-style-type: none"> <li>• Read through the safety instructions before operating the equipment. Failure to comply may result in death, personal injuries, or equipment damage.</li> <li>• Do not touch the terminals or remove the cover with power ON or within 10 min after power-off. Failure to comply will result in an electric shock.</li> </ul>

# 1 Product Information

## 1.1 Nameplate and Model Number of the Servo Drive

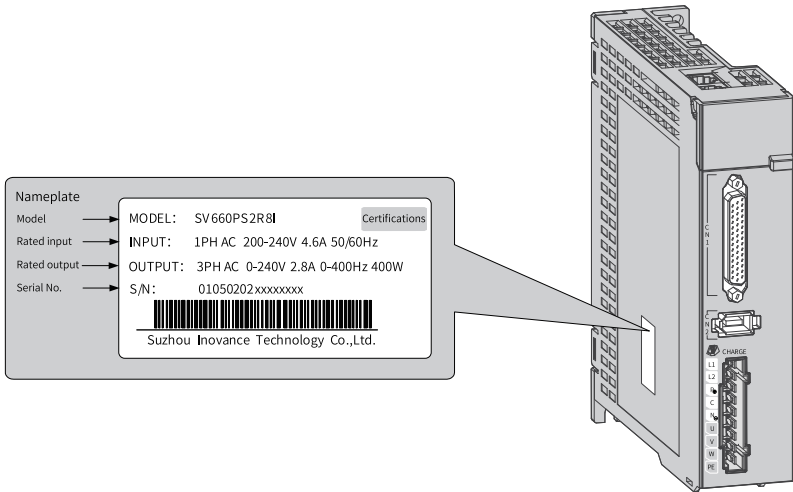
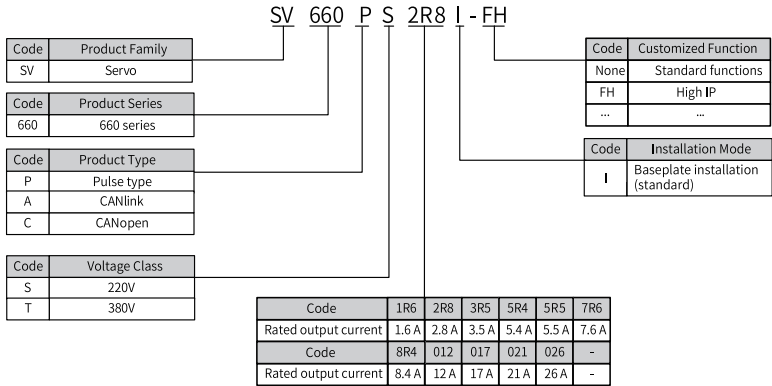
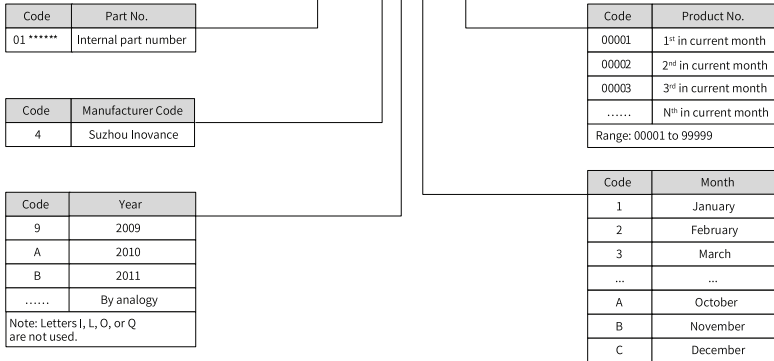

Figure 1-1 Nameplate and model number of the servo drive

01050202 4 H 7 00001



Example: The serial number 010502024H700001 indicates the servo drive is manufactured in July 2017.

Figure 1-2 Encryption of the production serial number

## 1.2 Nameplate and Model Number of the Servo Motor

MS1 H4 - 75B 30C B - A3 3 1 Z - S

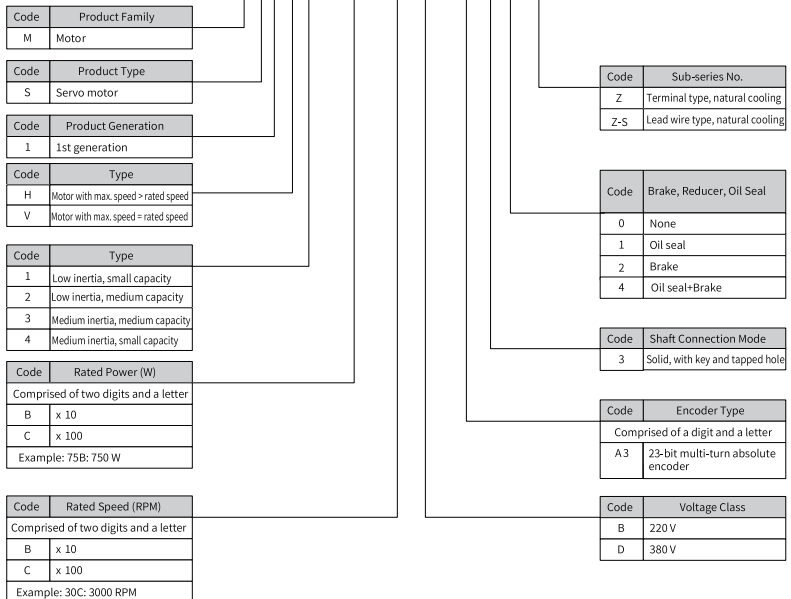

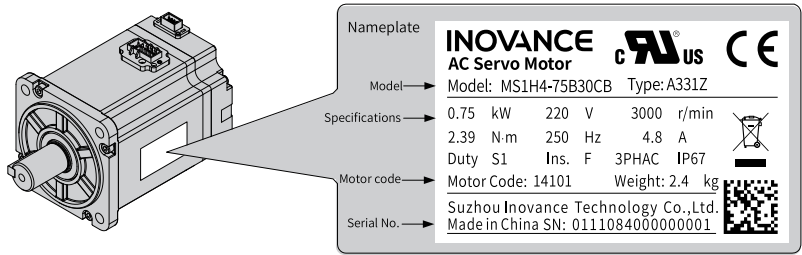

Figure 1-3 Nameplate and model number of the servo drive

## Note

The SV660P series servo drive can work with the servo motor configured with a 23-bit single-turn or multi-turn absolute encoder.

## 1.3 Model Number of Cables

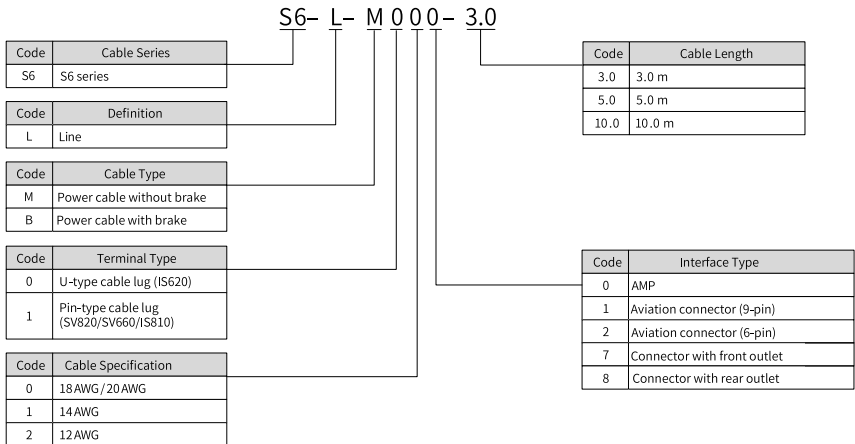

Figure 1-4 Model number of power cables

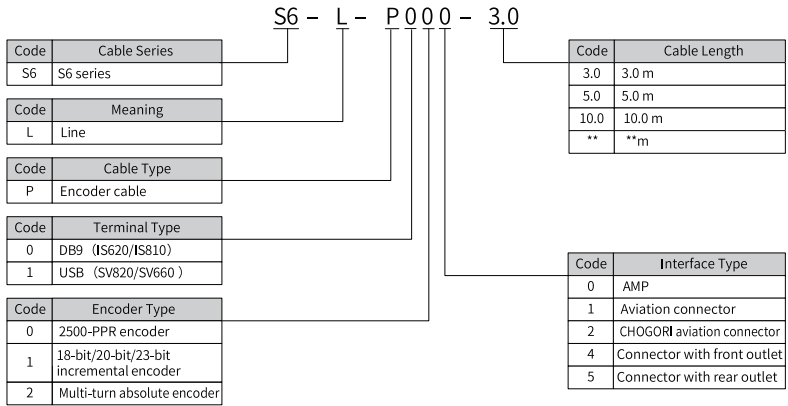

Figure 1-5 Model number of the encoder cable

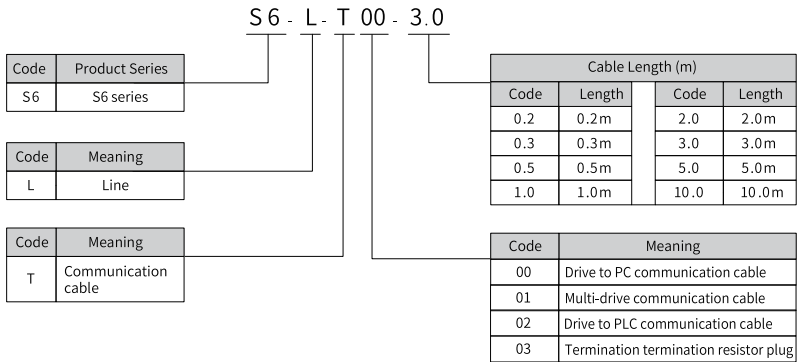

Figure 1-6 Model number of communication cables



## 1.4 Components

### 1.4.1 Servo Drives in Size A (Rated Power: 200 W to 400 W)

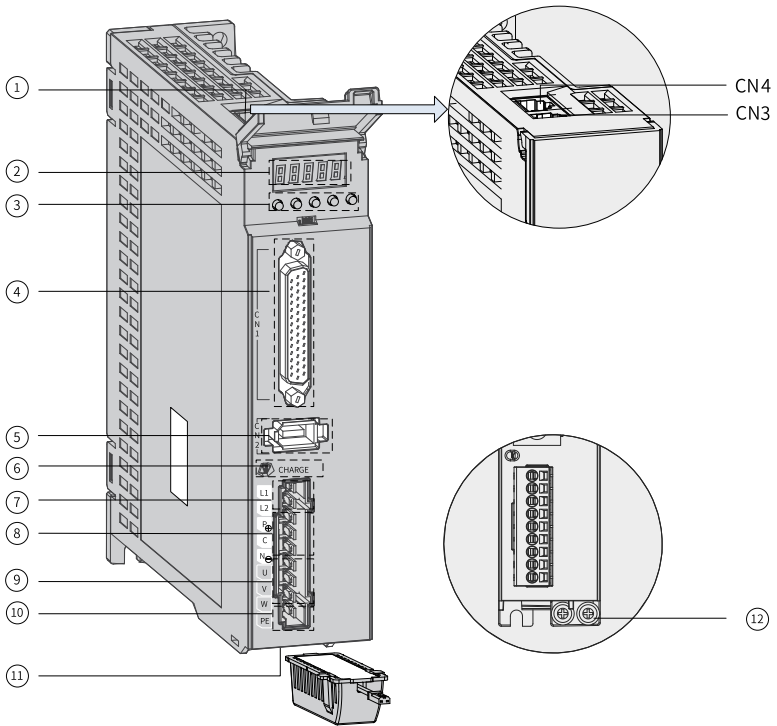

Figure 1-7 Components of servo drives in size A (SV660PS1R6I, SV660PS2R8I)

Table 1-1 Description of components (SV660PS1R6I, SV660PS2R8I)

No.	Name	Description
1	CN3, CN4 (communication terminals)	Connected to RS232 and RS485 host controllers in parallel.
2	5-digit LED display	Used to display the servo drive operating status and set parameters.

No.	Name	Description
3	Keys	MODE: Used to switch parameters in sequence. $\triangle$ : Used to increase the value of the blinking bit. $\nabla$ : Used to decrease the value of the blinking bit. $\triangleleft$ : Used to shift the blinking bit leftwards. (Hold down: Turning to the next page when the displayed number exceeds five digits) SET: Used to save modifications and enter the next menu.
4	CN1 (control terminal)	Used by reference input signals and other I/O signals.
5	CN2 (terminal for connecting the encoder)	Connected to the motor encoder terminal.
6	CHARGE (bus voltage indicator)	Used to indicate the electric charge is present in the bus capacitor. When this indicator lights up, it indicates the electric charge may be still present in the internal capacitor of the servo drive even though the main circuit power supply is switched off. To prevent electric shock, do not touch the power supply terminals when this indicator lights up.
7	L1, L2 (power input terminals)	See the nameplate for the rated voltage class.
	P $\oplus$ , N $\emptyset$ (DC bus terminals)	Used by the common DC bus for multiple servo drives.
8	P $\oplus$ , C (terminals for connecting external regenerative resistor)	If an external regenerative resistor is needed, connect it between terminals P $\oplus$ and C.
9	U, V, W (terminals for connecting the servo motor)	Connected to U, V, and W phases of the servo motor.
10	Motor grounding terminal	Connected to the grounding terminal of the motor for grounding purpose.
11	Battery location	Used to hold the battery box of the absolute encoder.
12	Servo drive grounding terminal	Connected to the grounding terminal of the power supply for grounding purpose.

## Note

The built-in regenerative resistor or jumper bar is not available in models S1R6 and S2R8. If an external regenerative resistor is needed for these models, connect it between terminals P $\oplus$  and C.

### 1.4.2 Servo Drives in Size B (Rated Power: 750 W)

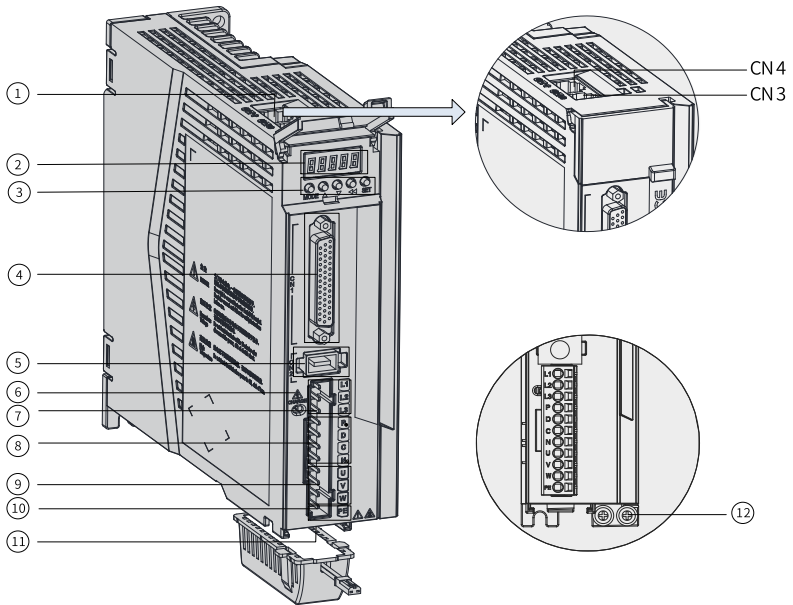

Figure 1-8 Description of servo drive components (SV660PS5R5I)

Table 1-2 Description of servo drive components (SV660PS5R5I)

No.	Name	Description
1	CN3, CN4 (communication terminals)	Connected to RS232 and RS485 host controllers in parallel.
2	5-digit LED display	Used to display the servo drive operating status and set parameters.
3	Keys	MODE: Used to switch parameters in sequence. △: Used to increase the value of the blinking bit. ▽: Used to decrease the value of the blinking bit. <: Used to shift the blinking bit leftwards. (Hold down: Turning to the next page when the displayed number exceeds five digits) SET: Used to save modifications and enter the next menu.
4	CN1 (control terminal)	Used by reference input signals and other I/O signals.
5	CN2 (terminal for connecting the encoder)	Connected to the motor encoder terminal.

No.	Name	Description
6	CHARGE (bus voltage indicator)	Used to indicate the electric charge is present in the bus capacitor. When this indicator lights up, it indicates the electric charge may be still present in the internal capacitor of the servo drive even though the main circuit power supply is switched off. To prevent electric shock, do not touch the power supply terminals when this indicator lights up.
7	L1, L2, L3 (power input terminals)	See the nameplate for the rated voltage class. Note: S5R5 (750 W) models support single-phase 220 V input only, with a 220 V power supply connected between terminals L1 and L2.
8	P⊕, N⊖ (DC bus terminals)	Used by the common DC bus for multiple servo drives.
	P⊕, D, C (terminals for connecting external regenerative resistor)	Remove the jumper bar between terminals P⊕ and D before connecting an external regenerative resistor between terminals P⊕ and C.
9	U, V, W (terminals for connecting the servo motor)	Connected to U, V, and W phases of the servo motor.
10	Motor grounding terminal	Connected to the grounding terminal of the motor for grounding purpose.
11	Battery location	Used to hold the battery box of the absolute encoder.
12	Servo drive grounding terminal	Connected to the grounding terminal of the power supply for grounding purpose.

### 1.4.3 Servo Drives in Size C and Size D (Rated Power: 1.0 kW to 3.0 kW)

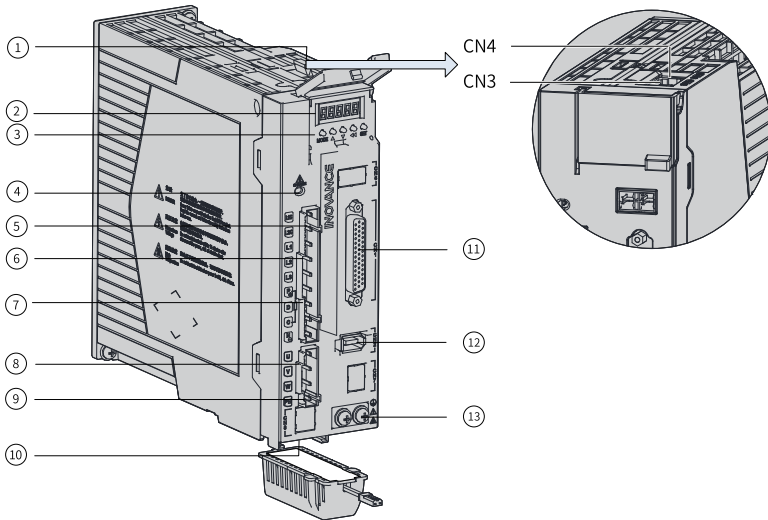

Figure 1-9 Components of servo drives in size C and size D (size C: SV660PS7R6I; size D: SV660PS012I)

Table 1-3 Description of components (Size C: SV660PS7R6I; size D: SV660PS012I)

No.	Name	Description
1	CN3, CN4 (communication terminals)	Connected to RS232 and RS485 host controllers in parallel.
2	5-digit LED display	Used to display the servo drive operating status and set parameters.
3	Keys	MODE: Used to switch parameters in sequence. △: Used to increase the value of the blinking bit. ▽: Used to decrease the value of the blinking bit. ◁: Used to shift the blinking bit leftwards. (Hold down: Turning to the next page when the displayed number exceeds five digits) SET: Used to save modifications and enter the next menu.
4	CHARGE (bus voltage indicator)	Used to indicate the electric charge is present in the bus capacitor. When this indicator lights up, it indicates the electric charge may be still present in the internal capacitor of the servo drive even though the main circuit power supply is switched off. To prevent electric shock, do not touch the power supply terminals when this indicator lights up.

No.	Name	Description
5	L1C, L2C (control circuit power input terminals)	See the nameplate for the rated voltage class.
6	L1, L2, L3 (main circuit power input terminals)	Used as the power input terminals for a three-phase 220 V servo drive. See the nameplate for the rated voltage class.
7	P⊕, D, C (terminals for connecting external regenerative resistor)	Remove the jumper bar between terminals P⊕ and D before connecting an external regenerative resistor between terminals P⊕ and C.
	P⊕, N⊖ (DC bus terminals)	Used by the common DC bus for multiple servo drives.
8	U, V, W (terminals for connecting the servo motor)	Connected to U, V, and W phases of the servo motor.
9	Motor grounding terminal	Connected to the grounding terminal of the motor for grounding purpose.
10	Battery location	Used to hold the battery box of the absolute encoder.
11	CN1 (control terminal)	Used by reference input signals and other I/O signals.
12	CN2 (terminal for connecting the encoder)	Connected to the motor encoder terminal.
13	Servo drive grounding terminals	Connected to the grounding terminal of the power supply for grounding purpose.

## Note

The main circuits of models S7R6 and S012 can be connected to a single-phase or a three-phase power supply, depending on which one is available on site. No derating is required when a single-phase power supply is used for models S7R6 and S012. The 220 V power supply can be connected between any two phases among L1, L2, and L3.

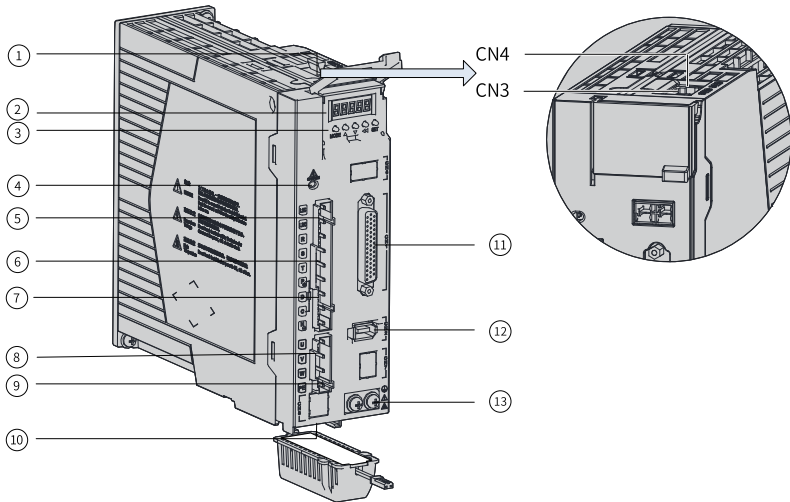

Figure 1-10 Components of servo drives in size C and size D (size C: SV660PT3R5I and SV660PT5R4I; size D: SV660PT8R4I and SV660PT012I)

Table 1-4 Description of components (Size C: SV660PT3R5I and SV660PT5R4I; size D: SV660PT8R4I and SV660PT012I)

No.	Name	Description
1	CN3, CN4 (communication terminals)	Connected to RS232 and RS485 communication command devices in parallel.
2	5-digit LED display	Used to display the servo drive operating status and set parameters.
3	Keys	MODE: Used to switch parameters in sequence. △: Used to increase the value of the blinking bit. ▽: Used to decrease the value of the blinking bit. ◁: Used to shift the blinking bit leftwards. (Hold down: Turning to the next page when the displayed number exceeds five digits) SET: Used to save modifications and enter the next menu.
4	CHARGE (bus voltage indicator)	Used to indicate the electric charge is present in the bus capacitor. When this indicator lights up, it indicates the electric charge may be still present in the internal capacitor of the servo drive even though the main circuit power supply is switched off. To prevent electric shock, do not touch the power supply terminals when this indicator lights up.

No.	Name	Description
5	L1C, L2C (control circuit power input terminals)	See the nameplate for the rated voltage class.
6	R, S, T (main circuit power input terminals)	Used as the power input terminals for a three-phase 380 V servo drive. See the nameplate for the rated voltage class.
7	P $\oplus$ , D, C (terminals for connecting external regenerative resistor)	Remove the jumper bar between terminals P $\oplus$ and D before connecting an external regenerative resistor between terminals P $\oplus$ and C.
	P $\oplus$ , N $\ominus$ (DC bus terminals)	Used by the common DC bus for multiple servo drives.
8	U, V, W (terminals for connecting the servo motor)	Connected to U, V, and W phases of the servo motor.
9	Motor grounding terminal	Connected to the grounding terminal of the motor for grounding purpose.
10	Battery location	Used to hold the battery box of the absolute encoder.
11	CN1 (control terminal)	Used by reference input signals and other I/O signals.
12	CN2 (terminal for connecting the encoder)	Connected to the motor encoder terminal.
13	Servo drive grounding terminal	Connected to the grounding terminal of the power supply for grounding purpose.



### 1.4.4 Servo Drives in Size E (Rated Power: 5.0 kW to 7.5 kW)

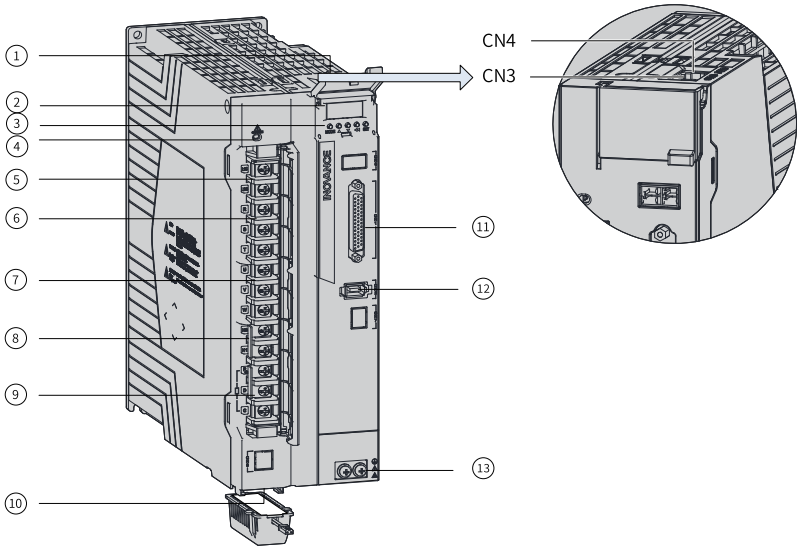

Figure 1-11 Components of servo drives in size E (SV660PT017I, SV660PT021I, SV660PT026I)

Table 1-5 Description of components (SV660PT017I, SV660PT021I, SV660PT026I)

No.	Name	Description
1	CN3, CN4 (communication terminals)	Connected to RS232 and RS485 host controllers in parallel.
2	5-digit LED display	Used to display the servo drive operating status and set parameters.
3	Keys	MODE: Used to switch parameters in sequence. △: Used to increase the value of the blinking bit. ▽: Used to decrease the value of the blinking bit. ◁: Used to shift the blinking bit leftwards. (Hold down: Turning to the next page when the displayed number exceeds five digits) SET: Used to save modifications and enter the next menu.
4	CHARGE (bus voltage indicator)	Used to indicate the electric charge is present in the bus capacitor. When this indicator lights up, it indicates the electric charge may be still present in the internal capacitor of the servo drive even though the main circuit power supply is switched off. To prevent electric shock, do not touch the power supply terminals when this indicator lights up.

No.	Name	Description
5	L1C, L2C (control circuit power input terminals)	See the nameplate for the rated voltage class.
6	R, S, T (main circuit power input terminals)	Used as the power input terminals for a three-phase 380 V servo drive. See the nameplate for the rated voltage class.
7	U, V, W (terminals for connecting the servo motor)	Connected to U, V, and W phases of the servo motor.
8	N2, N1 (terminals for connecting external reactor)	Terminals N1 and N2 are jumpered by default. To suppress harmonics in the power supply, remove the jumper between terminals N1 and N2 first and connect an external DC reactor between terminals N1 and N2.
9	P $\oplus$ , D, C (terminals for connecting external regenerative resistor)	Remove the jumper bar between terminals P $\oplus$ and D before connecting an external regenerative resistor between terminals P $\oplus$ and C.
10	Battery location	Used to hold the battery box of the absolute encoder.
11	CN1 (control terminal)	Used by reference input signals and other I/O signals.
12	CN2 (terminal for connecting the encoder)	Connected to the motor encoder terminal.
13	PE terminal	Connected to the grounding terminals of the power supply and the motor for grounding purpose.

### 1.4.5 Servo Motors in Flange Sizes 40/60/80

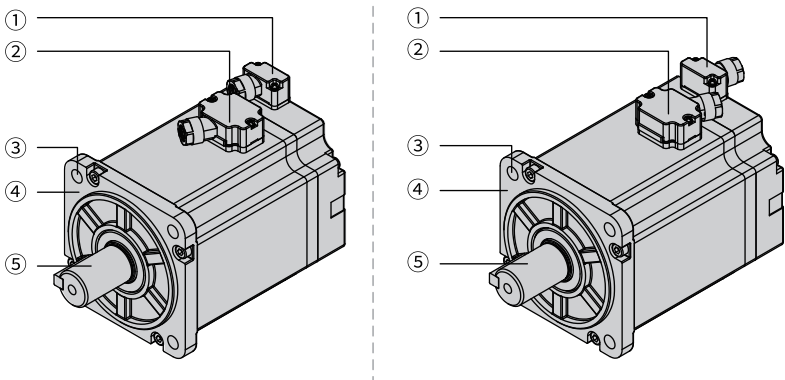

Figure 1-12 Components of terminal-type motors (Left: motor with front cable outlet; Right: motor with rear cable outlet)

Table 1-6 Components of terminal-type motors

No.	Name
1	Encoder socket
2	Power socket
3	Mounting flange face
4	Mounting screw through-hole
5	Shaft extension (with key)

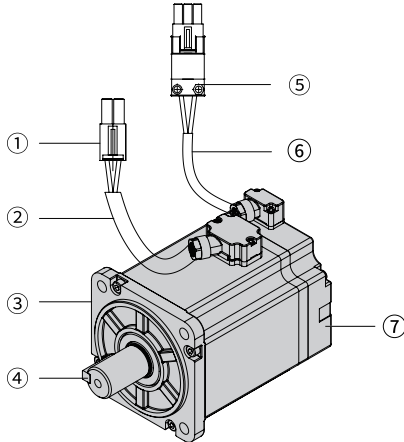

Figure 1-13 Components of lead wire-type motors

Table 1-7 Components of lead wire-type motors

No.	Name
1	Power cable connector
2	Power cable
3	Mounting flange face
4	Output shaft
5	Encoder connector
6	Encoder cable
7	Encoder (detection part)

### 1.4.6 Servo Motors in Flange Sizes 100/130/180

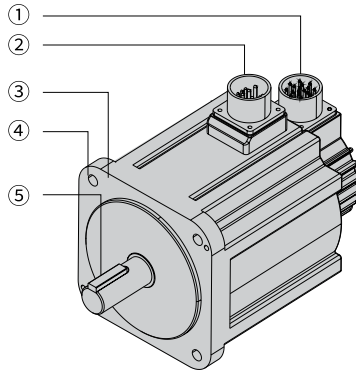

Figure 1-14 Components of servo drives in flange sizes 100/130/180

Table 1-8 Components of servo drives in flange sizes 100/130/180

No.	Name
1	Encoder connector
2	Power cable connector
3	Mounting flange face
4	Mounting screw through-hole
5	Shaft extension (with key)

## 2 Installation

Read through the safety instructions in Chapter "Fundamental Safety Instructions". Failure to comply may result in serious consequences.



- Observe the installation direction described in this chapter. Failure to comply may result in equipment fault or damage.
- Do not install or operate damaged or defective equipment. Failure to comply will result in personal injury.
- Do not install the equipment in environments exposed to water splashes or corrosive gases. Failure to comply will result in equipment fault.
- Do not install the equipment near inflammable gases or combustible objects. Failure to comply will result in a fire or electric shock.
- Install the equipment inside a fire-proof cabinet that provides electrical protection. Failure to comply may result in a fire.
- Ensure the specified clearance is reserved among the servo drive, the interior surface of the control cabinet, and other machines. Failure to comply will result in a fire or equipment fault.
- Do not put heavy objects on the equipment. Failure to comply may result in personal injury or equipment damage.
- Do not impose large impact on the equipment. Failure to comply may result in equipment damage.
- Do not block the air inlet/outlet of the equipment or allow unwanted objects to fall into the equipment. Failure to comply may result in a fire or equipment fault.

### 2.1 Installing the Servo Drive

#### 2.1.1 Unpacking Inspection

Check the following items upon unpacking.

Items	Description
Check whether the delivered product is consistent with your order.	Check whether the servo drive model and specifications comply with your order. See the dimensions of the packing box in <a href="#">"Table 2-1 " on page 29</a> . The deliverables include the product, cushion, carton box, and screw bag, as shown in <a href="#">"Figure 2-1 " on page 29</a> .
Check whether the product is intact.	Check whether the product delivered is in good condition. If there is any part missing or damaged, contact Inovance or your supplier immediately.

Table 2-1 Dimensions of the outer packing box

Specifications	Outer Width (mm)	Outer Height (mm)	Outer Depth (mm)
Size A (SV660PS1R6I, SV660PS2R8I)	250.0	90.0	195
Size B (SV660PS5R5I)	225.0	90	205.0
Size C (SV660PS7R6I, SV660PT3R5I, T5R4I)	235.0	105.0	215.0
Size D (SV660PS012I, SV660PT8R4I, T012I)	235.0	130.0	225.0
Size E (SV660PT017I, SV660PT021I, T026I)	320.0	150.0	280.0

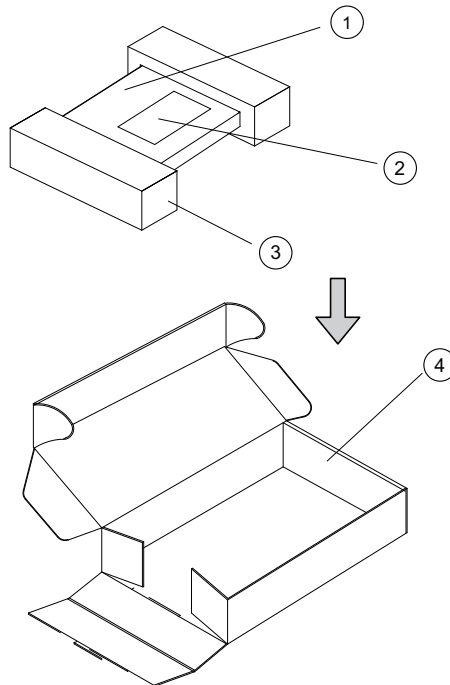

Figure 2-1 Contents inside the packing box

No.	Name
1	Product
2	Terminal accessories (varying with product models)

No.	Name
3	Cushion
4	Carton box

## 2.1.2 Installation Environment

Table 2-2 Environment requirement

Item	Requirement
Installation location	Indoors
Grid overvoltage	Overvoltage Category III (OVC III)
Altitude	<p>The maximum altitude is 5000 m.</p> <ul style="list-style-type: none"> <li>• For altitudes not higher than 1000 m, derating is not required.</li> <li>• For altitudes above 1000 m, derate 1% for every additional 100 m.</li> <li>• For altitudes above 2000 m, contact Inovance.</li> </ul>
Temperature	<ul style="list-style-type: none"> <li>• Mounting/Operating temperature: 0°C to 55°C For temperatures between 0°C to 45°C, derating is not required. For temperatures above 45°C, derate 2% for every additional 1°C.</li> <li>• Storage/Transportation temperature: -40°C to +70°C</li> <li>• To improve the reliability of the machine, use the servo drive in environments without dramatic temperature change.</li> <li>• When installing the servo drive into an enclosed environment such as a control cabinet, use a cooling fan or air conditioner to keep the temperature of the inlet air below 45°C. Failure to comply will result in over-temperature or a fire.</li> <li>• Install the servo drive on the surface of an incombustible object and leave sufficient surrounding space for heat dissipation.</li> <li>• Take measures to prevent the servo drive from being frozen.</li> </ul>
Ambient humidity	Below 90% RH (without condensation)
Storage humidity	Below 90%RH (without condensation)
Vibration	<p>Below 4.9 m/s<sup>2</sup></p> <ul style="list-style-type: none"> <li>• During transportation with packing box: compliant with EN 60721-3-2 Class 2M3</li> <li>• During installation without packing box: compliant with ISTA 1H</li> </ul>
Impact	Below 19.6 m/s <sup>2</sup>

Item	Requirement
IP rating	IP20
Environment	<p>Pollution Degree 2 and below</p> <p>Install the servo drive in a place that meets the following requirements:</p> <ul style="list-style-type: none"> <li>• Free from direct sunlight, dust, corrosive gas, explosive and inflammable gas, oil mist, vapor, water drop, and salty element</li> <li>• Insusceptible to vibration (away from equipment that may generate strong vibration, such as a punch press)</li> <li>• Without the risk of intrusion of unwanted objects into the servo drive, such as metal powder, oil, and water</li> <li>• Free from radioactive substances, combustible materials, harmful gases and liquids, and salt corrosion</li> <li>• Away from combustible materials such as wood</li> </ul>

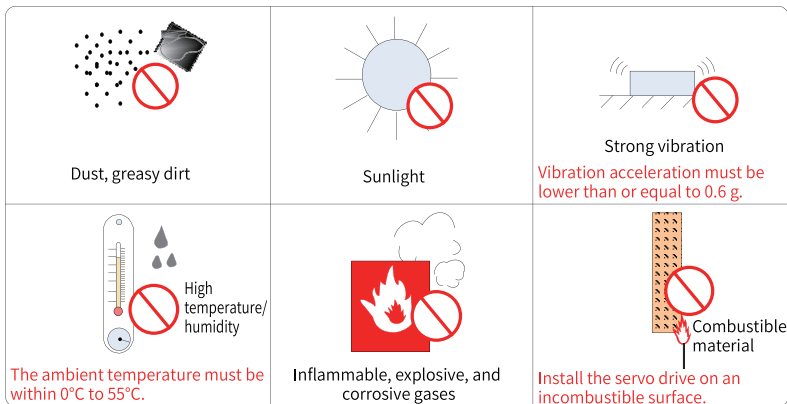

Figure 2-2 Environment requirements

### 2.1.3 Installation Clearance

Servo drives in different power ratings require different installation clearances. When installing multiple servo drives side by side, it is recommended to reserve a clearance of at least 10 mm (0.39 in.) between every two servo drives and a clearance of at least 50 mm (1.97 in.) above and below each servo drive for heat dissipation.



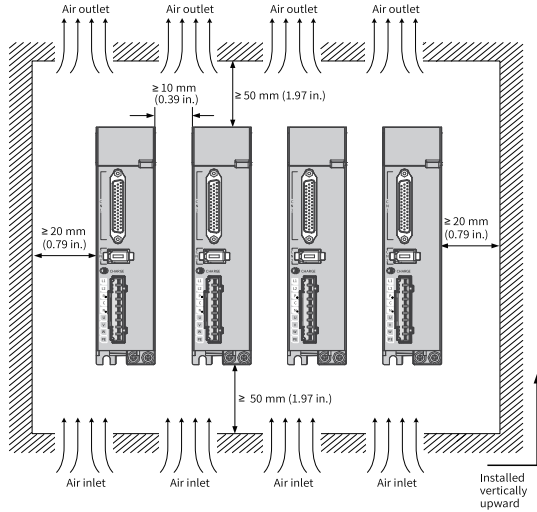

Figure 2-3 Clearance for side-by-side installation

Servo drives in size A and size B (rated power: 200 W to 750 W) support compact installation, in which a clearance of at least 1 mm (0.04 in.) must be reserved between every two servo drives. When adopting compact installation, derate the load rate to 75%.

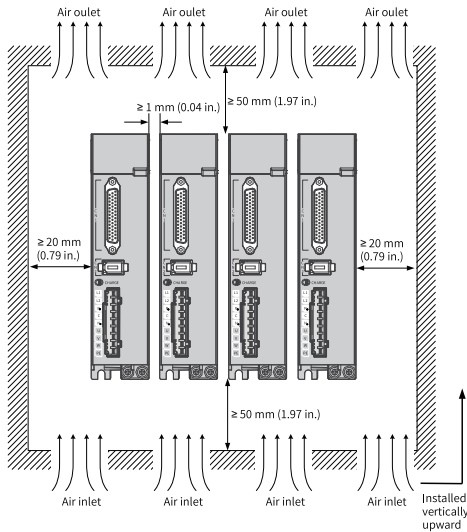

Figure 2-4 Clearance for compact installation

Servo drives in sizes C, D and E (rated power: 1.0 kW to 7.5 kW) support zero-clearance installation between every two servo drives, without the need for derating.

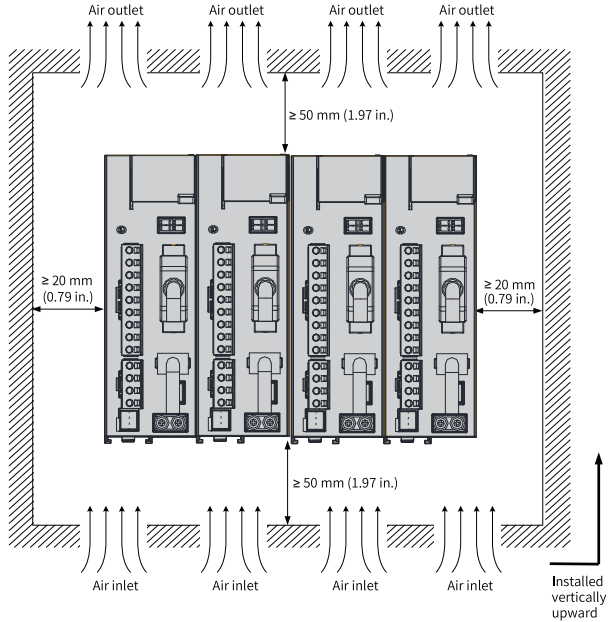

Figure 2-5 Zero-clearance installation

## 2.1.4 Installation Dimensions

Servo drives in size A (rated power: 200 W to 400 W): SV660PS1R6I, SV660PS2R8I

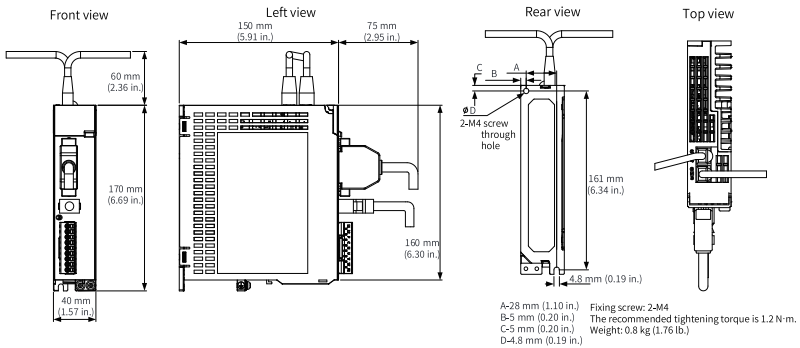

Figure 2-6 Dimension drawing of servo drives in size A

**Servo drives in size B (rated power: 750 W): SV660PS5R5I**

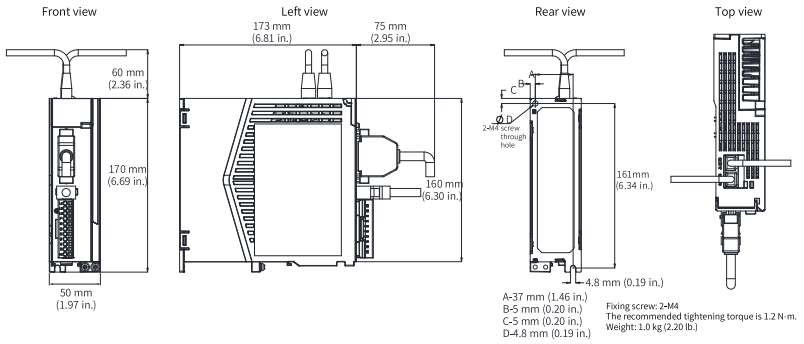

Figure 2-7 Dimension drawing of servo drives in size B

**Servo drives in size C (rated power: 1.0 kW to 1.5 kW): SV660PS7R6I, SV660PT3R5I, and SV660PT5R4I**

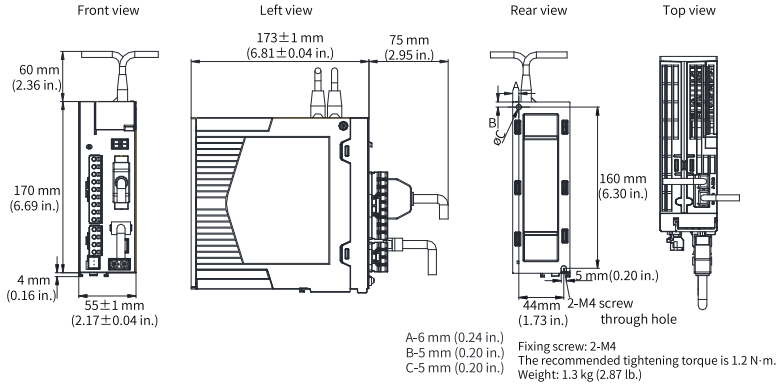

Figure 2-8 Dimension drawing of servo drives in size C

**Servo drives in size D (rated power: 1.5 kW to 3.0 kW): SV660PS012I, SV660PT8R4I, and SV660PT012I**

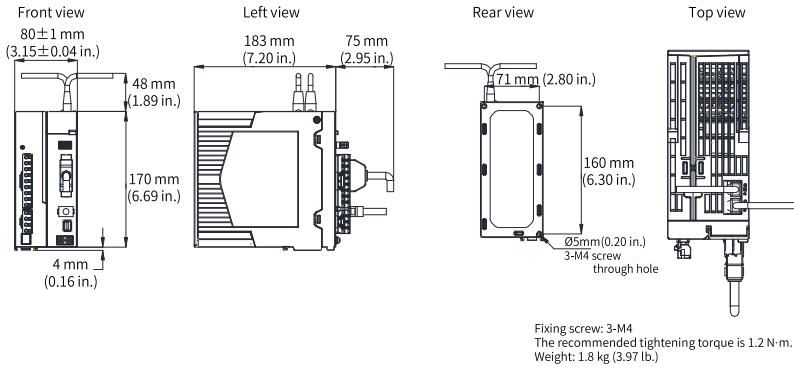

Figure 2-9 Dimension drawing of servo drives in size D

**Servo drives in size E (rated power: 5.0 kW to 7.5 kW): SV660PT017I, SV660PT021I, and SV660PT026I**

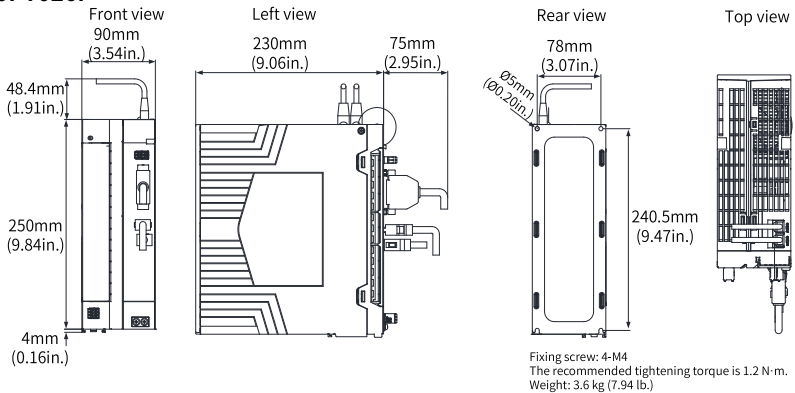
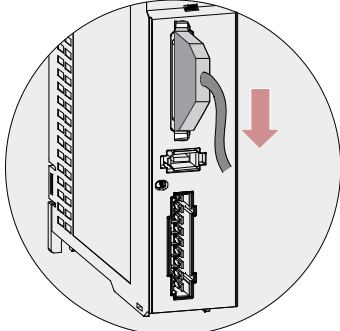
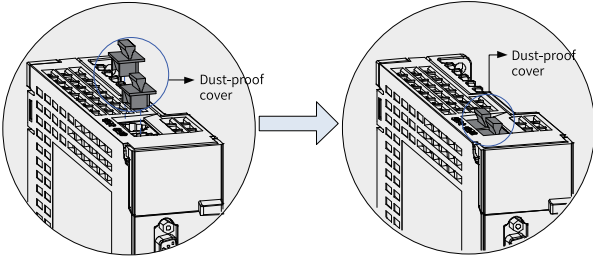

Figure 2-10 Dimension drawing of servo drives in size E

## 2.1.5 Installation Precautions

Table 2-3 Installation precautions

Item	Description
Installation Method	<ul style="list-style-type: none"> <li>• Install the servo drive vertically upward to facilitate heat dissipation. For installation of multiple servo drives inside the cabinet, install them side by side. For dual-row installation, install an air guide plate.</li> <li>• Make sure the servo drive is installed vertically to the wall. Cool the servo drive down with natural convection or a cooling fan. Secure the servo drive to the mounting surface through two to four mounting holes (the number of mounting holes depends on the capacity of the servo drive).</li> <li>• Install the servo drive vertically to the wall, with its front (actual mounting face) facing the operator.</li> <li>• The mounting bracket (if needed) must be made of incombustible materials.</li> </ul>
Cooling	As shown in <a href="#">"2.1.3 Installation Clearance" on page 31</a> , leave sufficient space around the servo drive to allow proper heat dissipation through the cooling fan or natural convection. Take the heat dissipated by other devices inside the cabinet into consideration. Install a cooling fan to the upper part of the servo drive to avoid excessive temperature rise in a certain area, keeping an even temperature inside the control cabinet.
Grounding	Ground the grounding terminal properly. Failure to comply may result in an electric shock or malfunction due to interference.

Item	Description
Routing	<p>As shown in the figure below, route the servo drive cables downwards to prevent liquids from flowing into the servo drive along the cables.</p>  <p>Route the cable downwards.</p>
Dust-proof cover (included in the standard configuration)	<p>Insert the dust-proof cover into the communication port (CN3/ CN4) not in use. This is to prevent unwanted objects, such as solids or liquids, from falling into the servo drive and resulting in faults.</p> <p>Each servo drive is delivered with two dust-proof covers. You can also place an order for more dust-proof covers as needed (model: NEX-02-N2B; manufacturer: PINGOOD).</p>  <p><b>Note:</b></p> <ul style="list-style-type: none"> <li>• Dust-proof cover: Prevents unwanted objects, such as solids or liquids, from falling into the servo drive and leading to faults.</li> <li>• Dust-proof covers are delivered along with the servo drive. Keep the dust-proof covers in a proper place.</li> </ul>

## 2.1.6 Installation Instructions

The servo drive supports backplate mounting only.

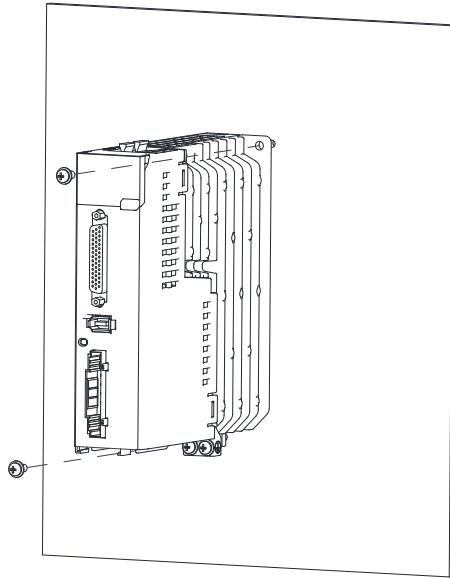

Figure 2-11 Backplate mounting

## Note

Servo drives in sizes A, B, and C are secured by two screws, with one screw on the top and the other one at the bottom. Servo drives in size D are secured by three screws, with two screws on the top and another one at the bottom. Servo drives in size E are secured by four screws, with two screws on the top and the other two at the bottom.

## 2.2 Installing the Servo Motor

### 2.2.1 Unpacking Inspection

Check the following items upon unpacking.

Items	Description
Check whether the delivered product is consistent with your order.	Check whether the motor model and specifications comply with your order. <b>Note:</b> Check whether the packing box is intact. If the packing box is damaged, contact your supplier immediately.
Check whether the product is intact.	Check whether the product delivered is in good condition. If there is any part missing or damaged, contact Inovance or your supplier immediately.

## 2.2.2 Installation Environment

Item	Requirement
Altitude	The maximum altitude is 5000 m. Derating is not required for altitudes above 1000 m. For altitudes above 1000 m, derate 1% for every additional 100 m. For altitudes above 2000 m, contact Inovance.
Ambient temperature	0°C to 40°C (non-freezing)
Storage temperature	-20°C to +60°C (Peak temperature: 80°C for 72 hours)
Ambient humidity	20%–80% RH (without condensation)
Storage humidity	20%–90% RH (without condensation)
Vibration	Below 49 m/s <sup>2</sup>
Shock	Below 490 m/s <sup>2</sup>
IP rating	After wiring is done, the overall IP rating of the motor is as follows: IP67 (shaft opening excluded, with power cables and encoder connectors installed properly)
Installation location	<ul style="list-style-type: none"> <li>• Install the servo motor in a place free from corrosive and inflammable gases and combustible materials, such as the hydrogen sulfide, chlorine, ammonia, sulphur gas, chloridize gas, acid, soda and salt.</li> <li>• Use the servo motor with oil seal when the motor is to be used in a place with grinding fluid, oil mist, iron powders or cuttings.</li> <li>• Install the servo motor away from heating sources such as a heating stove.</li> <li>• Do not use the servo motor in an enclosed environment. Running in an enclosed environment will lead to motor over-temperature, which shortens its service life.</li> </ul>



## 2.2.3 Installation Dimensions

### Dimension drawings of MS1H1 series motors

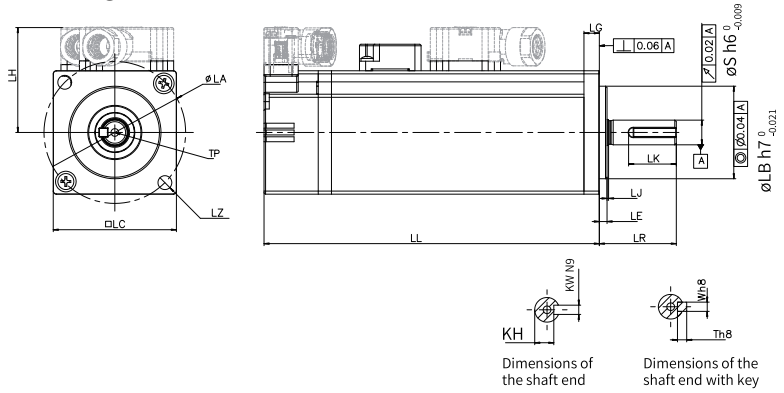

Figure 2-12 Dimension drawing of terminal-type motors

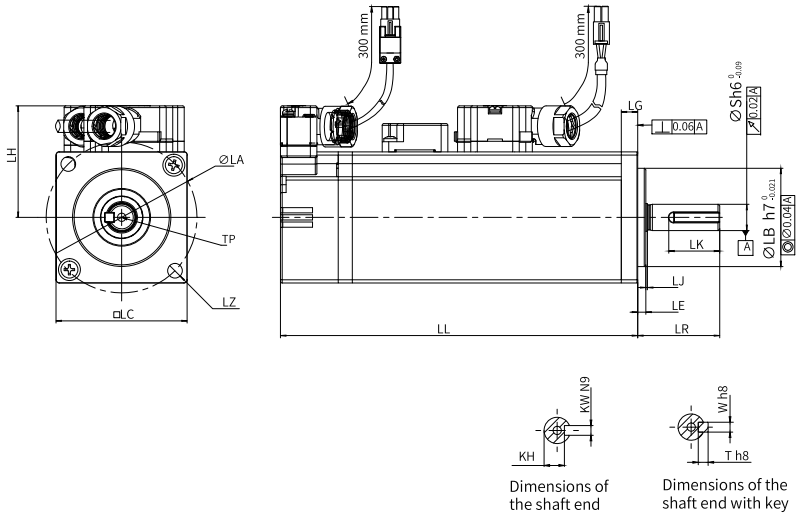

Figure 2-13 Dimension drawing of lead wire-type motors

Motor Model	LC	LL	LR	LA	LZ	LH	LG	LE	LJ
	Unit: mm (in.)								
MS1H1-05B30CB-A330Z(-S)	40 (1.57)	65 (2.56)	25±0.5 (0.98±0.02)	46 (1.81)	2-φ4.5 (0.08-φ0.18)	34 (1.34)	5 (0.20)	2.5±0.5 (0.10±0.02)	0.5±0.35 (0.02±0.01)
MS1H1-05B30CB-A332Z(-S)		96.00 (3.78)							
MS1H1-10B30CB-A330Z(-S)	40 (1.57)	77.5 (3.05)	25±0.5 (0.98±0.02)	46 (1.81)	2-φ4.5 (0.08-φ0.18)	34 (1.34)	5 (0.20)	2.5±0.5 (0.10±0.02)	0.5±0.35 (0.02±0.01)
MS1H1-10B30CB-A332Z(-S)		109 (4.29)							
MS1H1-20B30CB-A331Z(-S)	60 (2.36)	72.5 (2.85)	30±0.5 (1.18±0.02)	70 (2.76)	4-φ5.5 (0.16-φ0.18)	44 (1.73)	7.5 (0.30)	3±0.5 (0.12±0.02)	0.5±0.35 (0.02±0.01)
MS1H1-20B30CB-A334Z(-S)		100 (3.94)							
MS1H1-40B30CB-A331Z(-S)	60 (2.36)	91 (3.58)	30±0.5 (1.18±0.02)	70 (2.76)	4-φ5.5 (0.16-φ0.18)	44 (1.73)	7.5 (0.30)	3±0.5 (0.12±0.02)	0.5±0.35 (0.02±0.01)
MS1H1-40B30CB-A334Z(-S)		119 (4.69)							
MS1H1-55B30CB-A331Z(-S)	80 (3.15)	96.2 (3.79)	35±0.5 (1.38±0.02)	90 (3.54)	4-φ7 (0.16-φ0.28)	54 (2.13)	7.7 (0.30)	3±0.5 (0.12±0.02)	0.5±0.35 (0.02±0.01)
MS1H1-75B30CB-A331Z(-S)	80 (3.15)	107 (4.21)	35±0.5 (1.38±0.02)	90 (3.54)	4-φ7 (0.16-φ0.28)	54 (2.13)	7.7 (0.30)	3±0.5 (0.12±0.02)	0.5±0.35 (0.02±0.01)
MS1H1-75B30CB-A334Z(-S)		140 (5.51)							
MS1H1-10C30CB-A331Z(-S)	80 (3.15)	118.2 (4.65)	35±0.5 (1.38±0.02)	90 (3.54)	4-φ7 (0.16-φ0.28)	54 (2.13)	7.7 (0.30)	3±0.5 (0.12±0.02)	0.5±0.35 (0.02±0.01)

Motor Model	S	LB	TP	LK	KH	KW	W	T	Weight
	Unit: mm (in.)								
MS1H1-05B30CB-A330Z(-S)	8 (0.31)	30 (1.18)	M3x6 (M3x0.24)	15.5 (0.61)	6.2 (0.24)	3 (0.12)	3 (0.12)	3 (0.12)	0.39 (0.86)
MS1H1-05B30CB-A332Z(-S)									0.5 (1.10)
MS1H1-10B30CB-A330Z(-S)	8 (0.31)	30 (1.18)	M3x6 (M3x0.24)	15.5 (0.61)	6.2 (0.24)	3 (0.12)	3.00 (0.12)	3 (0.12)	0.45 (0.99)
MS1H1-10B30CB-A332Z(-S)									0.64 (1.41)
MS1H1-20B30CB-A331Z(-S)	14 (0.55)	50 (1.97)	M5x8 (M3x0.31)	16.5 (0.65)	11 (0.43)	5 (0.20)	5 (0.20)	5 (0.20)	0.78 (1.72)
MS1H1-20B30CB-A334Z(-S)									1.16 (2.56)
MS1H1-40B30CB-A331Z(-S)	14 (0.55)	50 (1.97)	M5x8 (M3x0.31)	16.5 (0.65)	11 (0.43)	5 (0.20)	5 (0.20)	5 (0.20)	1.11 (2.45)
MS1H1-40B30CB-A334Z(-S)									1.48 (3.26)
MS1H1-55B30CB-A331Z(-S)	19 (0.75)	70 (2.76)	M6x20 (M3x0.79)	25 (0.98)	15.5 (0.61)	6 (0.24)	6 (0.24)	6 (0.24)	1.85 (4.08)
MS1H1-75B30CB-A331Z(-S)	19 (0.75)	70 (2.76)	M6x20 (M3x0.79)	25 (0.98)	15.5 (0.61)	6 (0.24)	6 (0.24)	6 (0.24)	2.18 (4.81)
MS1H1-75B30CB-A334Z(-S)									2.82 (6.22)
MS1H1-10C30CB-A331Z(-S)	19 (0.75)	70 (2.76)	M6x20 (M3x0.79)	25 (0.98)	15.5 (0.61)	6 (0.24)	6 (0.24)	6 (0.24)	2.55 (5.62)

## Note

- Values inside the parentheses "(") are in British units.
- The tightening tension for terminal screws must be between 0.19 N·m to 0.21 N·m, exceeding of which may damage the terminal.
- For dimension drawings of motor models ending with "-S", contact Inovance technical support.

## Dimension drawings of MS1H2 series motors

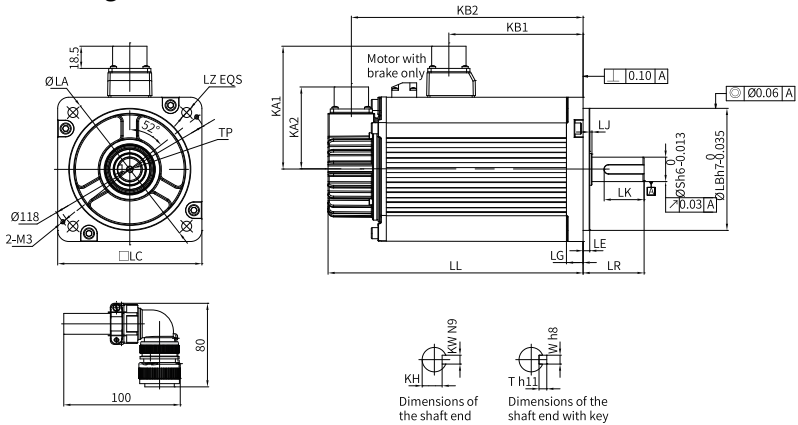

Figure 2-14 Dimension drawing of MS1H2 series motors

Motor Model	LC	LL	LR	LA	LZ	KA1	KB1	KA2	KB2	LG	LE	LJ	LB
	Unit: mm (in.)												
MS1H2-10C30CB(D)-A331Z	100 (3.94)	164 (6.46)	45±1 (1.77±0.04)	115 (4.53)	4-φ7 (0.16-φ0.28)	88 (3.46)	94.5 (3.72)	74 (2.91)	143.5 (5.65)	10 (0.39)	5±0.3 (0.20±0.01)	2.5±0.75 (0.10±0.03)	95 (3.74)
MS1H2-10C30CB(D)-A334Z		213.5 (8.41)					101 (3.98)		192.5 (5.65)				
MS1H2-15C30CB(D)-A331Z	100 (3.94)	189 (7.44)	45±1 (1.77±0.04)	115 (4.53)	4-φ7 (0.16-φ0.28)	88 (3.46)	119.5 (4.70)	74 (2.91)	168.5 (6.63)	10 (0.39)	5±0.3 (0.20±0.01)	2.5±0.75 (0.10±0.03)	95 (3.74)
MS1H2-15C30CB(D)-A334Z		239 (9.41)					128 (5.04)		219.50 (8.64)				
MS1H2-20C30CD-A331Z	100 (3.94)	214 (8.43)	45±1 (1.77±0.04)	115 (4.53)	4-φ7 (0.16-φ0.28)	88 (3.46)	144.5 (5.69)	74 (2.91)	193.5 (7.62)	10 (0.39)	5±0.3 (0.20±0.01)	2.5±0.75 (0.10±0.03)	95 (3.74)
MS1H2-20C30CD-A334Z(-S4)		265 (10.43)					153 (6.02)		244 (9.61)				

Motor Model	LC	LL	LR	LA	LZ	KA1	KB1	KA2	KB2	LG	LE	LJ	LB
	Unit: mm (in.)												
MS1H2-25C30CD-A331Z	100 (3.94)	240.5 (9.47)	45±1 (1.77±0.04)	115 (4.53)	4-φ7 (0.16-φ0.28)	88 (3.46)	169.5 (6.67)	74 (2.91)	218.5 (8.60)	10 (0.39)	5±0.3 (0.20±0.01)	2.5±0.75 (0.10±0.03)	95 (3.74)
MS1H2-25C30CD-A334Z(-S4)		290 (11.42)					178 (7.01)		269 (10.59)				
MS1H2-30C30CD-A331Z	130 (5.12)	209.5 (8.25)	63±1 (2.48±0.04)	145 (5.71)	4-φ9 (0.16-φ0.35)	103 (4.06)	136 (5.35)	74 (2.91)	188.5 (7.42)	14 (0.55)	6±0.3 (0.24±0.01)	0.5±0.75 (0.10±0.03)	110 (4.33)
MS1H2-30C30CD-A334Z(-S4)		265.5 (10.45)					139 (5.47)		244.5 (9.63)				
MS1H2-40C30CD-A331Z	130.00 (5.12)	252 (9.92)	63±1 (2.48±0.04)	145.00 (5.71)	4-φ9 (0.16-φ0.35)	103 (4.06)	178.5 (7.03)	74 (2.91)	231 (9.09)	14 (0.55)	6±0.3 (0.24±0.01)	0.5±0.75 (0.10±0.03)	110 (4.33)
MS1H2-40C30CD-A334Z(-S4)		308 (12.13)					181.5 (7.15)		287 (11.30)				
MS1H2-50C30CD-A331Z	130 (5.12)	294.5 (11.59)	63±1 (2.48±0.04)	145 (5.71)	4-φ9 (0.16-φ0.35)	103 (4.06)	221 (8.70)	74 (2.91)	273.5 (10.77)	14.00 (0.55)	6±0.3 (0.24±0.01)	0.5±0.75 (0.10±0.03)	110 (4.33)
MS1H2-50C30CD-A334Z(-S4)		350.5 (13.80)					224 (8.82)		329.5 (12.97)				

Installation

Motor Model	S	TP	LK	KH	KW	W	T	Weight	Conne tor Model	Power Side (Power Brake Side Included)	Encoder Side			
Unit: mm (in.)								Unit: kg (lb.)						
MS1H2-10C30CB(D)-A331Z	24 (0.94)	M8x16 (M8x0.63)	36 (1.42)	20 <sup>0</sup> -0.2 (0.78 <sup>0</sup> -0.01)	8 (0.31)	8 (0.31)	7 (0.28)	5.11 (11.27)	Aviation connec tor	MI-DTL-5015 series 3102E20-18P	MI-DTL-5015 series 3102E20-29P			
MS1H2-10C30CB(D)-A334Z								6.41 (14.13)						
MS1H2-15C30CB(D)-A331Z	24 (0.94)	M8x16 (M8x0.63)	36 (1.42)	20 <sup>0</sup> -0.2 (0.78 <sup>0</sup> -0.01)	8 (0.31)	8 (0.31)	7 (0.28)	6.22 (13.71)						
MS1H2-15C30CB(D)-A334Z								7.52 (16.58)						
MS1H2-20C30CD-A331Z	24 (0.94)	M8x16 (M8x0.63)	36 (1.42)	20 <sup>0</sup> -0.2 (0.78 <sup>0</sup> -0.01)	8 (0.31)	8 (0.31)	7 (0.28)	7.39 (16.29)						
MS1H2-20C30CD-A334Z(-S4)								8.7 (19.18)						
MS1H2-25C30CD-A331Z	24 (0.94)	M8x16 (M8x0.63)	36 (1.42)	20 <sup>0</sup> -0.2 (0.78 <sup>0</sup> -0.01)	8 (0.31)	8 (0.31)	7 (0.28)	8.55 (18.85)						
MS1H2-25C30CD-A334Z(-S4)								9.80 (21.61)						
MS1H2-30C30CD-A331Z	28 (1.10)	M8x20 (M8x0.79)	54 (2.13)	24 <sup>0</sup> -0.2 (0.94 <sup>0</sup> -0.01)	8 (0.31)	8 (0.31)	7 (0.28)	10.73 (23.66)				Aviation connec tor	MI-DTL-5015 series 3102E20-18P	MI-DTL-5015 series 3102E20-29P
MS1H2-30C30CD-A334Z(-S4)								13.2 (29.10)						
MS1H2-40C30CD-A331Z	28 (1.10)	M8x20 (M8x0.79)	54 (2.13)	24 <sup>0</sup> -0.2 (0.94 <sup>0</sup> -0.01)	8 (0.31)	8 (0.31)	7 (0.28)	15.43 (34.02)						
MS1H2-40C30CD-A334Z(-S4)								17.9 (39.46)						
MS1H2-50C30CD-A331Z	28 (1.10)	M8x20 (M8x0.79)	54 (2.13)	24 <sup>0</sup> -0.2 (0.94 <sup>0</sup> -0.01)	8 (0.31)	8 (0.31)	7 (0.28)	16.2 (35.71)						
MS1H2-50C30CD-A334Z(-S4)								18.7 (41.23)						

## Note

- Values inside the parentheses "()" are in British units.
- The tightening tension for terminal screws must be between 0.19 N·m to 0.21 N·m, exceeding of which may damage the terminal.
- Motor models ending with "-S4" represents the duty type S4, indicating the motor works in S4 duty, with the motor load rate not exceeding 70%.

## Dimension drawings of MS1H3 series motors

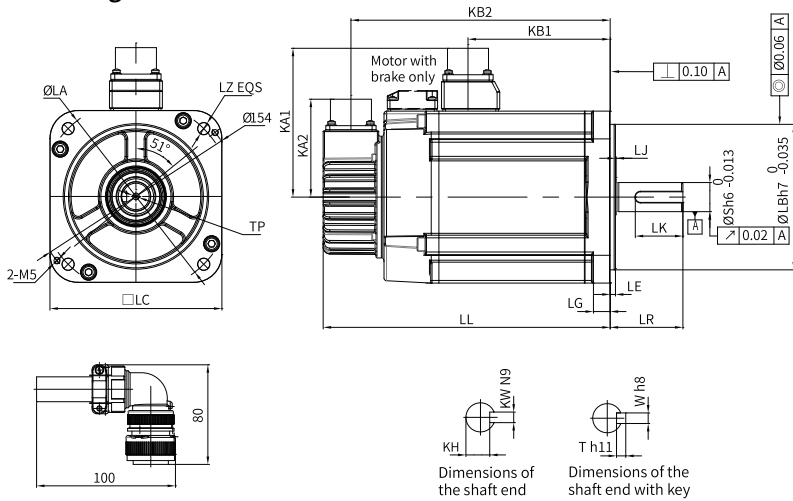

Figure 2-15 Dimension drawing of MS1H3 series motors

Motor Model	LC	LL	LR	LA	LZ	KA1	KB1	KA2	KB2	LG	LE	LJ	LB
	Unit: mm (in.)												
MS1H3-85B15CB(D)-A331Z	130 (5.12)	146 (5.75)	55±1 (2.17±0.04)	145 (5.71)	4-Φ9 (0.16-Φ0.35)	103 (4.06)	72.5 (2.85)	74 (2.91)	125 (4.92)	14 (0.55)	4 (0.16)	0.5±0.75 (0.02±0.03)	110 (4.33)
MS1H3-85B15CB(D)-A334Z		182 (7.17)							161 (6.34)				
MS1H3-13C15CB(D)-A331Z	130 (5.12)	163 (6.42)	55±1 (2.17±0.04)	145.00 (5.71)	4-Φ9 (0.16-Φ0.35)	103 (4.06)	89.5 (3.52)	74 (2.91)	142 (5.59)	14 (0.55)	4 (0.16)	0.5±0.75 (0.02±0.03)	110 (4.33)
MS1H3-13C15CB(D)-A334Z		199 (7.83)							178 (7.01)				

Motor Model	LC	LL	LR	LA	LZ	KA1	KB1	KA2	KB2	LG	LE	LJ	LB
	Unit: mm (in.)												
MS1H3-18C15CD-A331Z	130 (5.12)	181 (7.13)	55±1 (2.17±0.04)	145 (5.71)	4-Φ9 (0.16-Φ0.35)	103 (4.06)	107.5 (4.23)	74 (2.91)	160 (6.30)	14 (0.55)	4 (0.16)	0.5±0.75 (0.02±0.03)	110 (4.33)
MS1H3-18C15CD-A334Z		196 (7.72)											
MS1H3-29C15CD-A331Z	180 (7.09)	197 (7.76)	79±1 (3.11±0.04)	200 (7.87)	4-Φ13.5 (0.16-Φ0.53)	138 (5.43)	136 (5.35)	74 (2.91)	177 (6.97)	18 (0.71)	3.2±0.3 (0.13±0.01)	0.3±0.75 (0.01±0.03)	114.3 (4.50)
MS1H3-29C15CD-A334Z		273 (10.75)	134 (5.28)				253 (9.96)						
MS1H3-44C15CD-A331Z	180 (7.09)	230 (9.06)	79±1 (3.11±0.04)	200 (7.87)	4-Φ13.5 (0.16-Φ0.53)	138 (5.43)	169 (6.65)	74 (2.91)	210 (8.27)	18 (0.71)	3.2±0.3 (0.13±0.01)	0.3±0.75 (0.01±0.03)	114.3 (4.50)
MS1H3-44C15CD-A334Z		307 (12.09)	167 (6.57)				286 (11.26)						
MS1H3-55C15CD-A331Z	180 (7.09)	274 (10.79)	113±1 (4.45±0.04)	200 (7.87)	4-Φ13.5 (0.16-Φ0.53)	138 (5.43)	213 (8.39)	74 (2.91)	254 (10.00)	18 (0.71)	3.2±0.3 (0.13±0.01)	0.3±0.75 (0.01±0.03)	114.3 (4.50)
MS1H3-55C15CD-A334Z		350 (13.78)	211 (8.31)				330 (12.99)						
MS1H3-75C15CD-A331Z	180 (7.09)	330 (12.99)	113±1 (4.45±0.04)	200 (7.87)	4-Φ13.5 (0.16-Φ0.53)	138 (5.43)	269 (10.59)	74 (2.91)	310 (12.20)	18 (0.71)	3.2±0.3 (0.13±0.01)	0.3±0.75 (0.01±0.03)	114.3 (4.50)
MS1H3-75C15CD-A334Z		407 (16.02)	267 (10.51)				386 (15.20)						

Motor Model	S	TP	LK	KH	KW	W	T	Weight	Connector Model	Power Side (Power Brake Side Included)	Encoder Side
	Unit: mm (in.)							Unit: kg (lb.)			
MS1H3-85B15CB(D)-A331Z	22 (0.87)	M6x20 (M6x0.79)	36 (1.42)	18 <sup>0</sup> -0.2 (0.71 <sup>0</sup> -0.01)	8 (0.31)	8 (0.31)	7 (0.28)	7 (15.43)	Aviation connector	MI-DTL-5015 series 3102E20-18P	MI-DTL-5015 series 3102E20-29P
MS1H3-85B15CB(D)-A334Z							8 (17.64)				
MS1H3-13C15CB(D)-A331Z	22 (0.87)	M6x20 (M6x0.79)	36 (1.42)	18 <sup>0</sup> -0.2 (0.71 <sup>0</sup> -0.01)	8 (0.31)	8 (0.31)	7 (0.28)	8 (17.64)			
MS1H3-13C15CB(D)-A334Z							9.50 (20.94)				
MS1H3-18C15CD-A331Z	22 (0.87)	M6x20 (M6x0.79)	36 (1.42)	18 <sup>0</sup> -0.2 (0.71 <sup>0</sup> -0.01)	8 (0.31)	8 (0.31)	7 (0.28)	9.5 (20.94)			
MS1H3-18C15CD-A334Z							11 (24.25)				
MS1H3-29C15CD-A331Z	35 (1.38)	M12x25 (M12x0.98)	65 (2.56)	30 <sup>0</sup> -0.2 (1.18 <sup>0</sup> -0.01)	10 (0.39)	10 (0.39)	8 (0.31)	15 (33.07)	Aviation connector	MI-DTL-5015 series 3102E20-22P	MI-DTL-5015 series 3102E20-29P
MS1H3-29C15CD-A334Z							25.00 (55.12)				
MS1H3-44C15CD-A331Z	35 (1.38)	M12x25 (M12x0.98)	65 (2.56)	30 <sup>0</sup> -0.2 (1.18 <sup>0</sup> -0.01)	10 (0.39)	10 (0.39)	8 (0.31)	19.5 (42.99)			
MS1H3-44C15CD-A334Z							30 (66.14)				
MS1H3-55C15CD-A331Z	42 (1.65)	M16x32 (M16x1.26)	96 (3.78)	37 <sup>0</sup> -0.2 (1.46 <sup>0</sup> -0.01)	12 (0.47)	12 (0.47)	8 (0.31)	28 (61.73)			
MS1H3-55C15CD-A334Z							38 (83.78)				
MS1H3-75C15CD-A331Z	42 (1.65)	M16x32 (M16x1.26)	96 (3.78)	37 <sup>0</sup> -0.2 (1.46 <sup>0</sup> -0.01)	12 (0.47)	12 (0.47)	8 (0.31)	32.00 (70.55)	Aviation connector		
MS1H3-75C15CD-A334Z							42 (92.59)				



## Note

- Values inside the parentheses "()" are in British units.
- The tightening tension for terminal screws must be between 0.19 N·m to 0.21 N·m, exceeding of which may damage the terminal.

## Dimension drawings of MS1H4 series motors

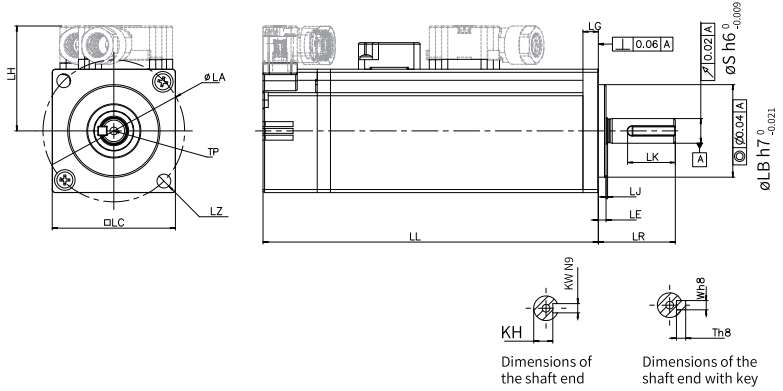

Figure 2-16 Dimension drawing of terminal-type motors

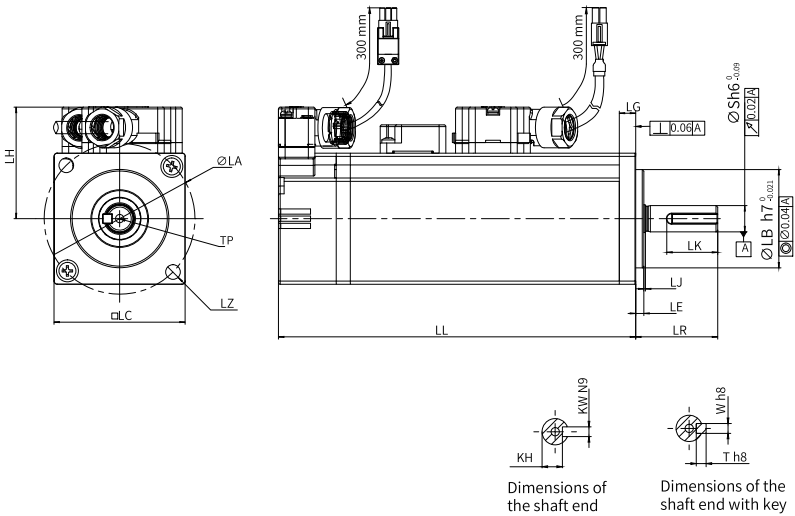

Figure 2-17 Dimension drawing of lead wire-type motors

Motor Model	LC	LL	LR	LA	LZ	LH	LG	LE	LJ
	Unit: mm (in.)								
MS1H4-40B30CB-A331Z(-S)	60 (2.36)	105 (4.13)	30±0.5 (1.18±0.02)	70 (2.76)	4-Φ5.5 (0.16-Φ0.22)	44 (1.73)	7.5 (0.3)	3±0.5 (0.12±0.02)	0.5±0.35 (0.02±0.01)
MS1H4-40B30CB-A334Z(-S)		128 (5.04)							
MS1H4-75B30CB-A331Z(-S)	80 (3.15)	117.5 (4.63)	35±0.5 (1.38±0.02)	90 (3.54)	4-Φ7 (0.16-Φ0.28)	54 (2.13)	7.7 (0.3)	3±0.5 (0.12±0.02)	0.5±0.35 (0.02±0.01)
MS1H4-75B30CB-A334Z(-S)		147.5 (5.81)							
Motor Model	LB	S	TP	LK	KH	KW	W	T	Weight
	Unit: mm (in.)								Unit: kg (lb.)
MS1H4-40B30CB-A331Z(-S)	50 (1.97)	14 (0.55)	M5x8 (M5x0.31)	16.5 (0.65)	11 (0.43)	5 (0.20)	5 (0.20)	5 (0.20)	1.27 (2.8)
MS1H4-40B30CB-A334Z(-S)									1.62 (3.57)
MS1H4-75B30CB-A331Z(-S)	70 (2.76)	19 (0.75)	M6x20 (M6x0.79)	25 (0.98)	15.5 (0.61)	6 (0.24)	6 (0.24)	6 (0.24)	2.4 (5.29)
MS1H4-75B30CB-A334Z(-S)									3.04 (6.7)

## Note

- Values inside the parentheses "()" are in British units.
- The tightening tension for terminal screws must be between 0.19 N·m to 0.21 N·m, exceeding of which may damage the terminal.
- For dimension drawings of motor models ending with "-S", contact Inovance technical support.

## 2.2.4 Installation Precautions

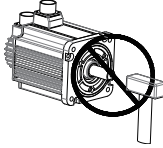
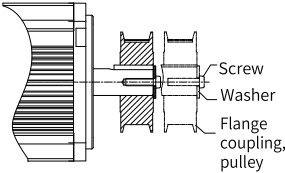
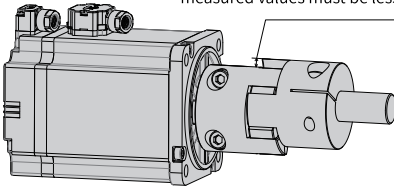
Item	Description
Rust-proof treatment	Wipe up the anti-rust agent applied at the motor shaft extension before installing the servo motor, and then take rust-proof measures.
Encoder	<ul style="list-style-type: none"> <li>Do not strike the shaft extension during installation. Failure to comply will damage the encoder.</li> </ul> 
	<ul style="list-style-type: none"> <li>Use the screw hole at the shaft end when mounting a pulley to the servo motor shaft with a keyway. To fit the pulley, insert a double-end screw into the screw hole of the shaft, put a washer on the coupling end, and then use a nut to push the pulley in.</li> <li>For the motor shaft with a keyway, use the screw hole at the shaft end for installation. For the motor shaft without a keyway, use friction coupling or similar methods.</li> <li>When removing the pulley, use a pulley remover to protect the shaft from suffering severe impact from load.</li> <li>To ensure safety, install a protective cover or similar device on the rotary area such as the pulley mounted on the shaft.</li> </ul> 
Alignment	<p>When connecting the servo motor to a machine, use a coupling and keep the motor shaft center and the machine shaft center in the same line. When installing the servo motor, make sure the alignment accuracy requirement shown in the following figure is fulfilled. Failure to comply will result in vibration that may damage the bearing and encoder.</p> <p>Measure the distance at four different positions on the circumference. The difference between the maximum and minimum measured values must be less than 0.03 mm.</p> 

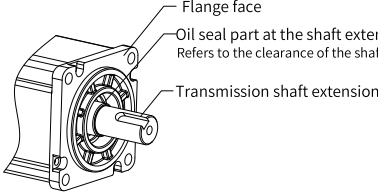
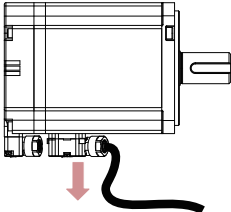
Item	Description
Installation direction	The servo motor can be installed horizontally or vertically.
Measures against oil and liquid	<ul style="list-style-type: none"> <li>• Do not submerge the motor/cable in water or oil.</li> <li>• Confirm the IP rating of the servo motor when the motor is to be used in a place with water drops (excluding the shaft opening).</li> </ul>  <ul style="list-style-type: none"> <li>• Install the motor with its connecting terminals facing downwards (as shown in the following figure) when the motor is to be used in a place with liquid. This is to prevent the liquid from flowing into the motor along the cable.</li> </ul>  <ul style="list-style-type: none"> <li>• In environments where the shaft opening is exposed to oil drops, use a servo motor with an oil seal.</li> <li>• Observe the following requirements when using the servo motor with an oil seal: <ul style="list-style-type: none"> <li>• Make sure the oil level is lower than the oil seal lip during use.</li> <li>• Prevent oil accumulation on the oil seal lip when the motor is installed vertically upward.</li> </ul> </li> </ul>

Item	Description
Stress of cables	Do not bend or pull the cable with excessive force, especially the signal wires whose conductors are only 0.2 mm or 0.3 mm in thickness.
Connectors	Pay attention to the following precautions <ul style="list-style-type: none"> <li>• Ensure there are no unwanted objects such as waste or sheet metal inside the connector.</li> <li>• Connect the connector to the main circuit cable side of the servo motor first, and make sure the grounding cable of the main circuit cable is connected reliably. If the connector is firstly connected to the encoder cable side, the encoder may become faulty due to the potential difference between PEs. Make sure the pins are correctly arranged during wiring.</li> <li>• The connector is made of resin. Do not strike the connector to prevent damage to the connector.</li> <li>• When transporting the servo motor with motor cables connected, hold the servo motor by its body instead of cables. Failure to comply may damage the connector and the cable.</li> <li>• If flexible cables are used, do not apply stress to the connector during wiring. Failure to comply may damage the connector.</li> </ul>

## 2.3 Installing the Optional Parts

### 2.3.1 Instructions for the Installing Fuse and Circuit Breaker



To prevent electric shocks, when the fuse is blown or the circuit breaker trips, wait for at least the time designated on the warning label before powering on the drive or operating peripheral devices. Failure to comply will result in death, severe personal injury, or equipment damage.

---

To comply with EN 61800-5-1 and UL 61800-5-1, install a fuse/circuit breaker on the input side of the servo drive to prevent accidents caused by short circuit in the internal circuit.

## 2.3.2 Instructions for Installing the AC Input Reactor

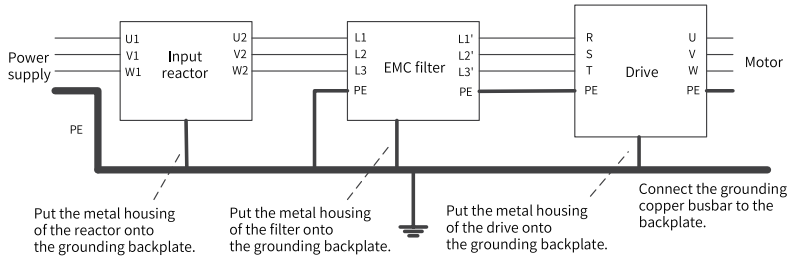

Figure 2-18 Installing the AC input reactor

## 2.3.3 Instructions for Installing the EMC Filter

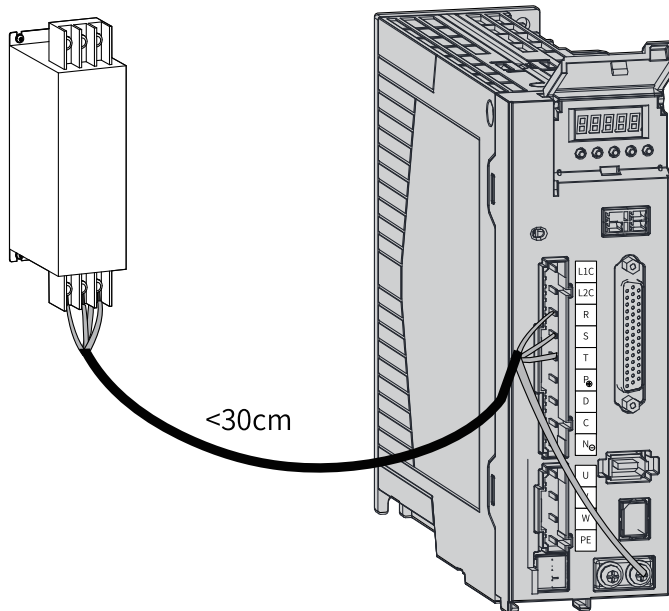

Figure 2-19 Installing the EMC filter

### 2.3.4 Instructions for Installing Magnetic Ring and Ferrite Clamp

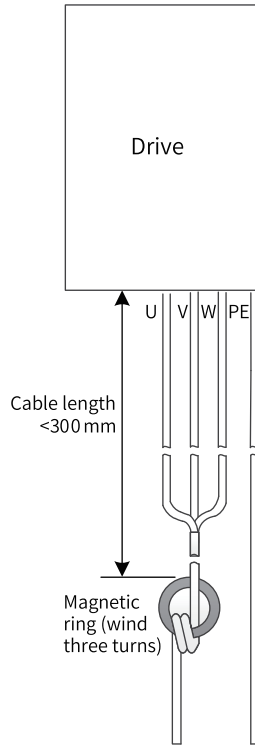

Figure 2-20 Installing the magnetic ring

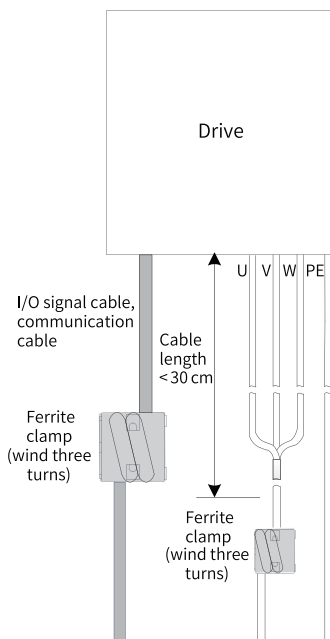

Figure 2-21 Installing the ferrite clamp



## 3 Wiring

### 3.1 Wiring Precautions

---



Read through the safety instructions in Chapter "Fundamental Safety Instructions". Failure to comply may result in serious consequences.

- Do not use the power from IT system for the drive. Use the power from TN/TT system for the drive. Failure to comply may result in an electric shock.
  - Connect an electromagnetic contactor between the input power supply and the main circuit power supply of the drive (L1, L2 for single-phase; L1, L2, L3/R, S, T for three-phase) to form a structure allowing independent power cutoff on the power supply side of the drive. This is to prevent fire accident caused by continuous high current generated upon fault.
  - Check that the input power supply of the drive is within the specified voltage range. Failure to comply may result in faults.
  - Do not connect the output terminals U, V, and W of the drive to a three-phase power supply. Failure to comply may result in physical injury or a fire.
  - Do not connect the motor terminals U, V, and W to a mains power supply. Failure to comply may result in physical injury or a fire.
  - Use the ALM (fault) signal to cut off the main circuit power supply. A faulty braking transistor may overheat the regenerative resistor and lead to a fire.
  - Connect the PE terminal of the drive to the PE terminal of the control cabinet. Failure to comply may result in an electric shock.
  - Ground the entire system properly. Failure to comply may result in equipment malfunction.
  - After the power supply is cut off, residual voltage is still present in the internal capacitor of the drive, wait for at least 15 min before further operations. Failure to comply may result in an electric shock.
-



- The specification and installation of external cables must comply with applicable local regulations.
- Observe the following requirements when the servo drive is used on a vertical axis.
  - Set the safety device properly to prevent the workpiece from falling upon warning or overtravel.
  - Ensure the positive/negative polarity of the 24 V power supply is correct. Otherwise, the axis may fall and cause personal injury or equipment damage.
- Observe the following requirements during wiring of the power supply and main circuit:
  - When the main circuit terminal is a connector, remove the connector from the servo drive before wiring.
  - Insert one cable into one cable terminal of the connector. Do not insert multiple cables into one cable terminal.
  - When inserting cables, take enough care to prevent the cable conductor burrs from being short circuited to the neighboring cable.
  - Insulate the connecting part of the power supply terminals to prevent electric shock.
  - Do not connect a 220 V servo drive to a 380 V power supply directly.
  - Install safety devices such as a circuit breaker to prevent short circuit in external circuits. Failure to comply may result in a fire.
  - Cut off the main circuit power supply and switch off the S-ON signal after an alarm signal is detected.
- Connect the servo drive to the motor directly. Do not use an electromagnetic contactor during wiring. Failure to comply may result in equipment fault.
- Do not put heavy objects onto cables or pull cables with excessive force. Failure to comply may result in cable damage, leading to an electric shock.
- When connecting DO terminals to relays, ensure the polarity of the flywheel diode is correct. Wrong polarity will result in equipment damage or signal output failure.
- Keep a distance of at least 30 cm between main circuit cables and I/O signal cables/encoder cables. Failure to comply may result in equipment malfunction.
- Use twisted pairs or multi-conductor shielded twisted pairs as the I/O signal cable or encoder cable. Failure to comply may result in equipment malfunction.
- The maximum wiring lengths of the I/O signal cable and the encoder cable are 3 m and 20 m respectively.
- Use a power supply filter to reduce the electromagnetic interference on electronic devices surrounding the servo drive.
- Take proper shielding measures in the following locations to prevent equipment damage:
  - Locations with interference caused by static electricity

- Locations with strong electric field or magnetic field
- Locations with radioactive rays

### 3.2 System Wiring Diagram

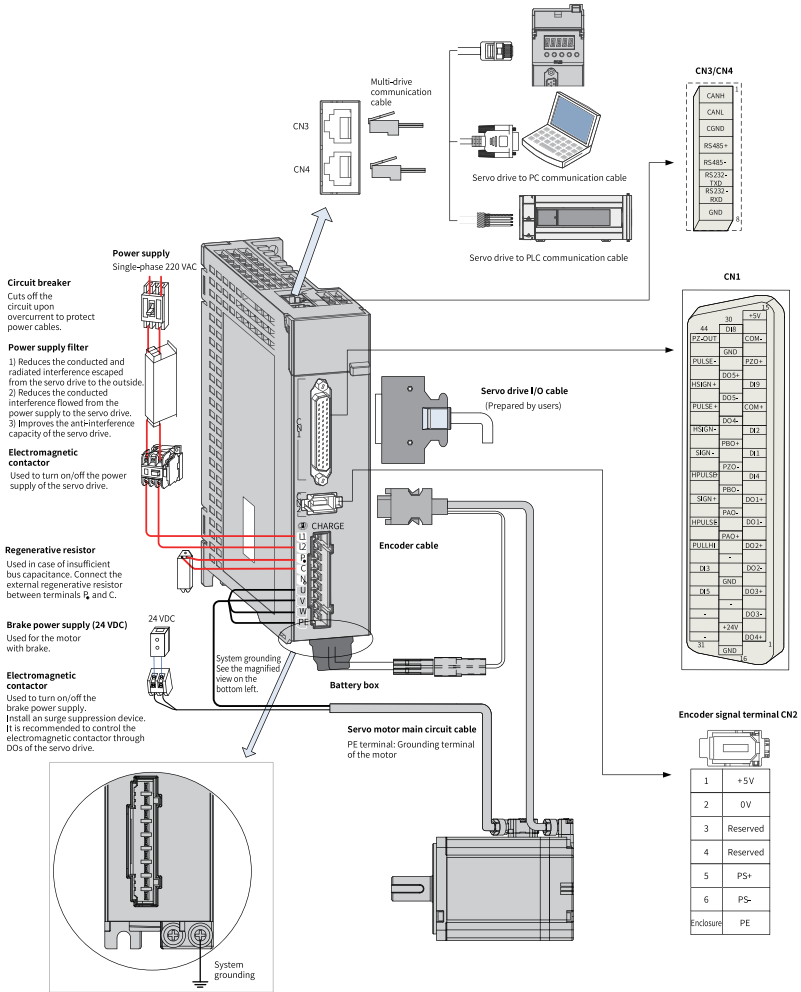

Figure 3-1 Wiring example of a single-phase 220 V system

- The servo drive is directly connected to an industrial power supply, with no isolation such as a transformer. A fuse or circuit breaker therefore must be connected to the input power supply to prevent electric shock in the servo system.

---

For the sake of safety, install a residual current device (RCD) to provide protections against overload and short circuit or a specialized RCD to protect the grounding cable.

- Do not start or stop the motor by using the electromagnetic contactor. As a high-inductance device, the motor may generate high voltages instantaneously, which may break down the contactor.
- When connecting an external power supply to the control circuit or a 24 VDC power supply, pay attention to the power capacity as insufficient power capacity will lead to insufficient supply current, resulting in failure of the servo drive or the brake. This is especially true when the power supply is used to power up multiple servo drives or brakes. The brake must be powered up by a 24 VDC power supply that matches the motor model and meets the brake power requirements.

---

## Note

[1] CN3 and CN4 are identical communication interfaces with the same pin assignment, and either can be used.

Observe the following precautions when connecting the external regenerative resistor:

- Remove the jumper between P $\oplus$  and D before using the external regenerative resistor. Failure to comply will result in overcurrent and damage the braking transistor.
  - Do not connect the external regenerative resistor to the positive or negative pole of the bus directly. Failure to comply will damage the servo drive or cause a fire.
  - Select a resistor with resistance higher than the minimum permissible value. Failure to comply will result in Er.201 (Overcurrent) or damage the servo drive.
  - Make sure parameters H02-25 (Regenerative resistor setting), H02-26 (Power of external regenerative resistor) and H02-27 (Resistance of external regenerative resistor) are set properly before operating the servo drive.
  - Install the external regenerative resistor on an incombustible object such as a metal.
-



- 
- When connecting an external power supply to the control circuit or a 24 VDC power supply, pay attention to the power capacity as insufficient power capacity will lead to insufficient supply current, resulting in failure of the servo drive or the brake. This is especially true when the power supply is used to power up multiple servo drives or brakes. The brake must be powered up by a 24 VDC power supply that matches the motor model and meets the brake power requirements.
- 

## Note

[1] CN3 and CN4 are identical communication interfaces with the same pin assignment, and either can be used.

Observe the following precautions when connecting the external regenerative resistor:

- Remove the jumper between P⊕ and D before using the external regenerative resistor. Failure to comply will result in overcurrent and damage the braking transistor.
  - Do not connect the external regenerative resistor to the positive or negative pole of the bus directly. Failure to comply will damage the servo drive or cause a fire.
  - Select a resistor with resistance higher than the minimum permissible value. Failure to comply will result in Er.201 (Overcurrent) or damage the servo drive.
  - Make sure parameters H02-25 (Regenerative resistor setting), H02-26 (Power of external regenerative resistor) and H02-27 (Resistance of external regenerative resistor) are set properly before operating the servo drive.
  - Install the external regenerative resistor on an incombustible object such as a metal.
-

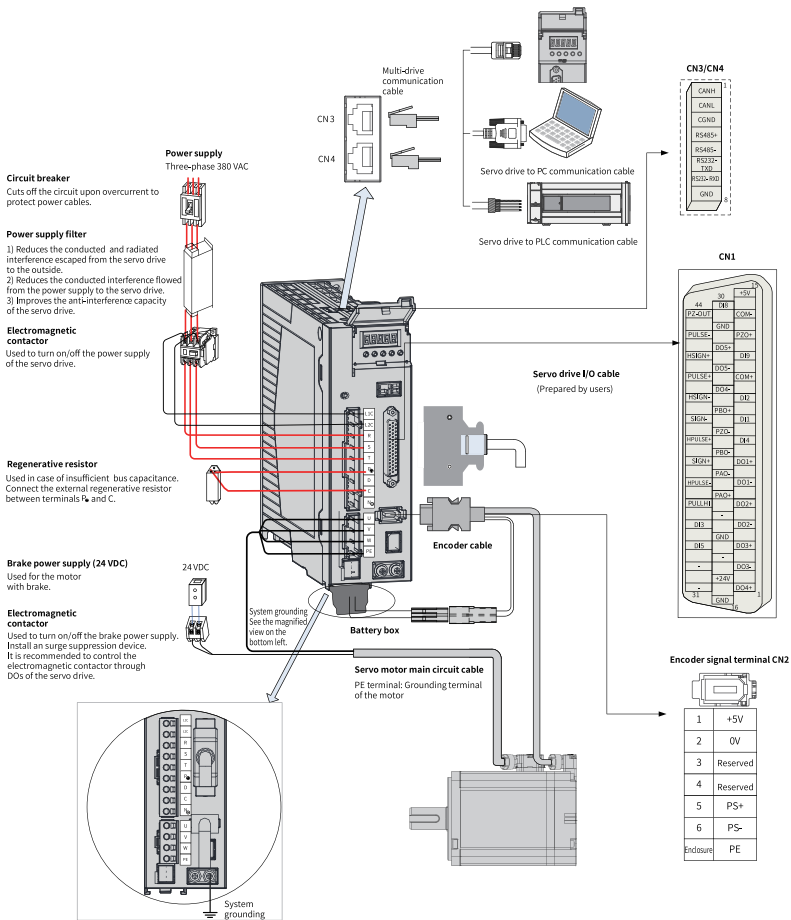

Figure 3-3 Wiring example of a three-phase 380 V system

- The servo drive is directly connected to an industrial power supply, with no isolation such as a transformer. A fuse or circuit breaker therefore must be connected to the input power supply to prevent electric shock in the servo system. For the sake of safety, install a residual current device (RCD) to provide protections against overload and short circuit or a specialized RCD to protect the grounding cable.
- Do not start or stop the motor by using the electromagnetic contactor. As a high-inductance device, the motor may generate high voltages instantaneously, which may break down the contactor.
- When connecting an external power supply to the control circuit or a 24 VDC power supply, pay attention to the power capacity as insufficient power capacity

---

will lead to insufficient supply current, resulting in failure of the servo drive or the brake. This is especially true when the power supply is used to power up multiple servo drives or brakes. The brake must be powered up by a 24 VDC power supply that matches the motor model and meets the brake power requirements.

---

## Note

[1] CN3 and CN4 are identical communication interfaces with the same pin assignment, and either can be used.

Observe the following precautions when connecting the external regenerative resistor:

- Remove the jumper between P $\oplus$  and D before using the external regenerative resistor. Failure to comply will result in overcurrent and damage the braking transistor.
  - Do not connect the external regenerative resistor to the positive or negative pole of the bus directly. Failure to comply will damage the servo drive or cause a fire.
  - Select a resistor with resistance higher than the minimum permissible value. Failure to comply will result in Er.201 (Overcurrent) or damage the servo drive.
  - Make sure parameters H02-25 (Regenerative resistor setting), H02-26 (Power of external regenerative resistor) and H02-27 (Resistance of external regenerative resistor) are set properly before operating the servo drive.
  - Install the external regenerative resistor on an incombustible object such as a metal.
-



### 3.3 Wiring Diagram for Different Control Modes

#### 3.3.1 Wiring Diagram for the Position Control Mode

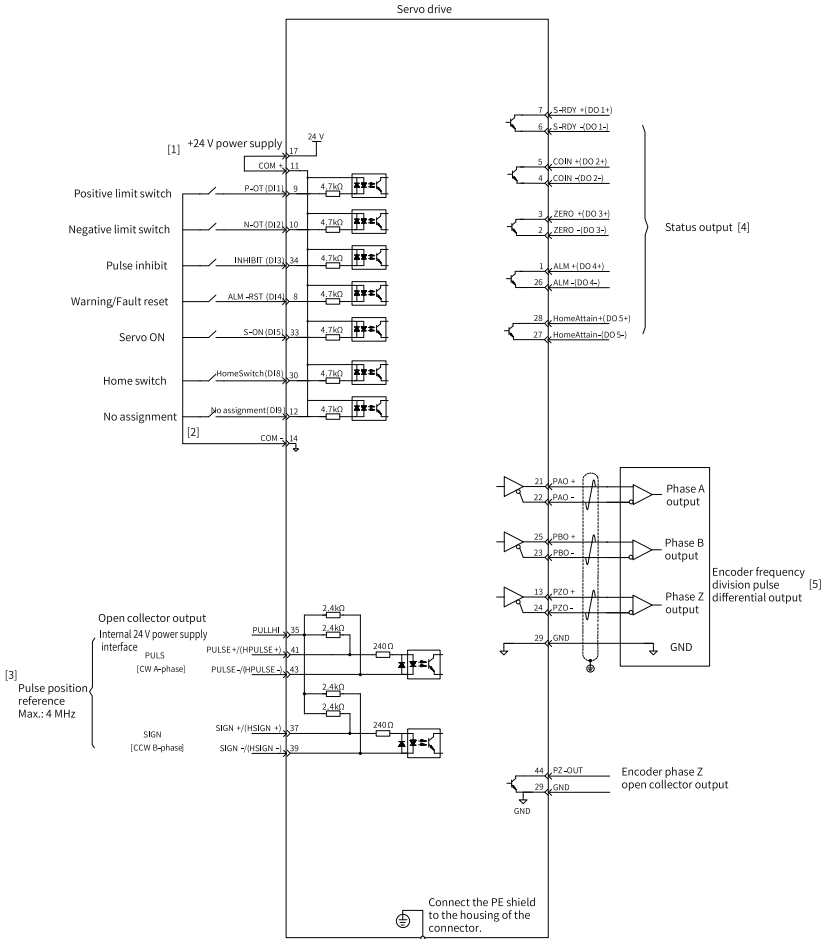

Figure 3-4 Wiring diagram for the position control mode

**Note**

- [1] The voltage range of the internal +24 V power supply is 20 V to 28 V, with maximum operating current being 200 mA.
  - [2] DI8 and DI9 are high-speed DIs that must be used according to their functions assigned.
  - [3] Use the shielded twisted pairs for pulse terminals, with both ends of the shield connected to PE. Connect GND to the signal GND of the host controller properly.
  - [4] The DO power supply (voltage range: 5 V to 24 V) needs to be prepared by users. The DO terminals support a maximum voltage of 30 VDC and a maximum current of 50 mA.
  - [5] Use the shielded twisted pair cable as frequency-division cable, with both ends of the shield connected to PE. Connect GND to the signal GND of the host controller properly.
-

### 3.3.2 Wiring Diagram for the Torque Control Mode

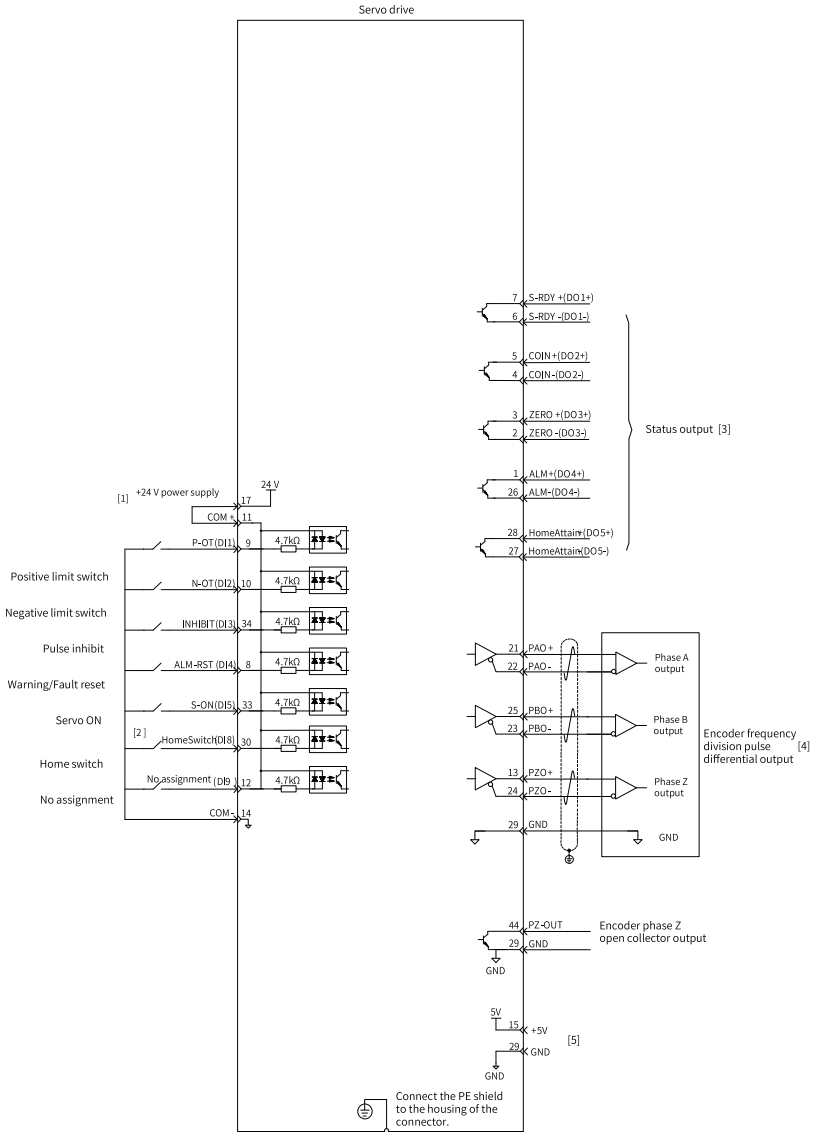

Figure 3-5 Wiring Diagram for the Torque Control Mode

**Note**

- [1] The voltage range of the internal +24 V power supply is 20 V to 28 V, with maximum operating current being 200 mA.
  - [2] DI8 and DI9 are high-speed DIs that must be used according to their functions assigned.
  - [3] The DO power supply (voltage range: 5 V to 24 V) needs to be prepared by users. The DO terminals support a maximum voltage of 30 VDC and a maximum current of 50 mA.
  - [4] Use shielded twisted pair cable as frequency-division cable, with both ends of the shield connected to PE. Connect GND to the signal GND of the host controller properly.
  - [5] The internal +5 V power supply supports a maximum current of 200 mA.
-

### 3.4 Terminal Layout of the Servo Drive

Servo drives in size A (rated power: 200 W to 400 W): SV660PS1R6I and SV660PS2R8I

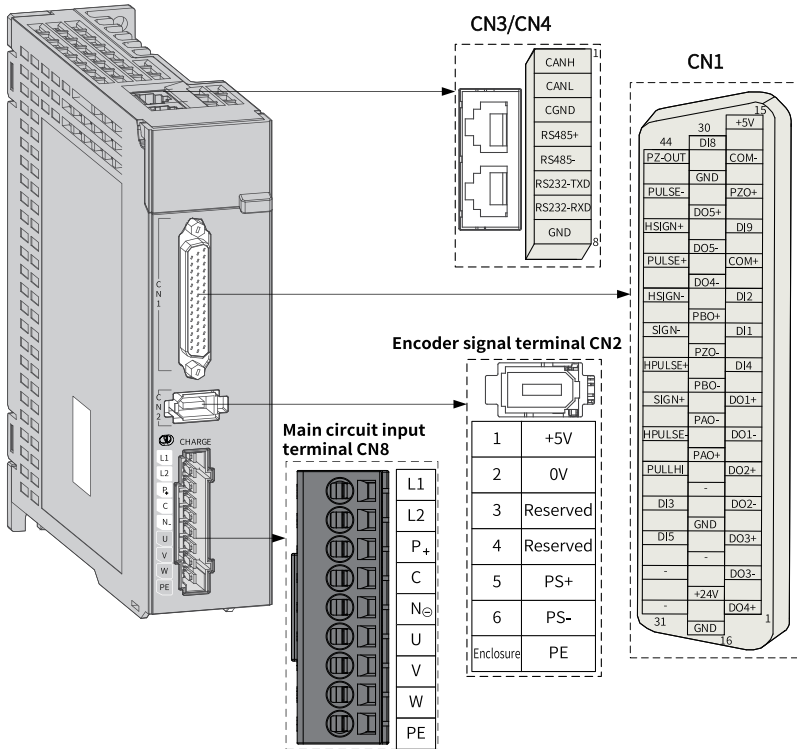

Figure 3-6 Terminal pin layout of servo drives in size A

**Servo drives in size B (rated power: 750 W): SV660PS5R51**  
**CN3/CN4**

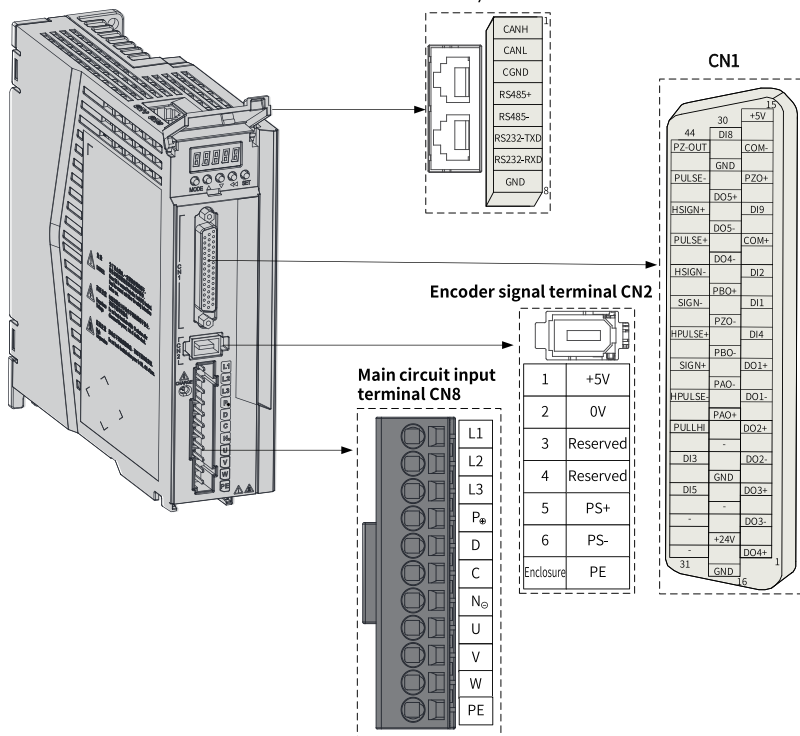

Figure 3-7 Terminal pin layout of servo drives in size B

**Servo drives in size C and size D (rated power: 1.0 kW to 1.5 kW): size C: SV660PS7R6I; size D: SV660PS012I**

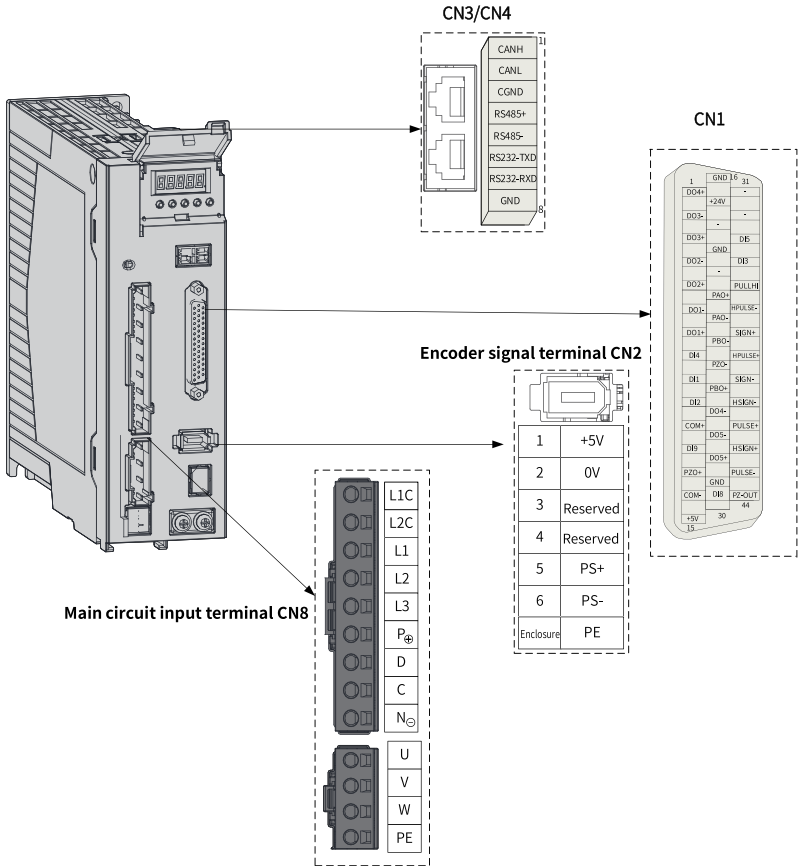

Figure 3-8 Terminal pin layout of servo drives in size C (SV660PS7R6I) and size D (SV660PS012I)

**Servo drives in size C and size D (rated power: 1.0 kW to 3.0 kW): size C: SV660PT3R5I and SV660PT5R4I; size D: SV660PT8R4I and SV660PT012I**

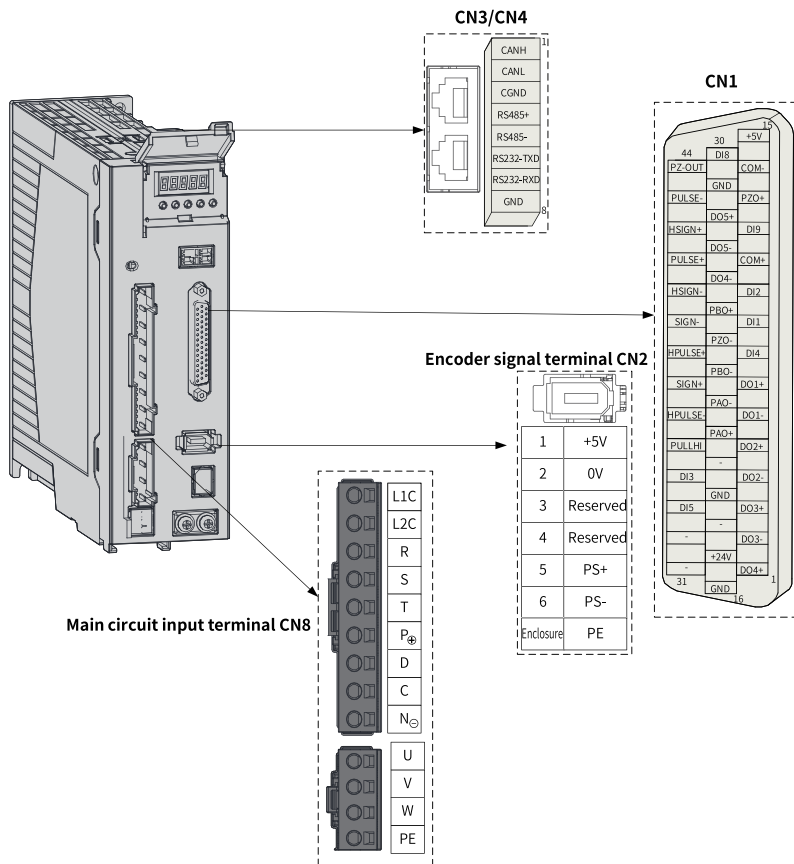

Figure 3-9 Terminal pin layout of servo drives in size C (SV660PT3R5I, SV660PT5R4I) and size D (SV660PT8R4I, SV660PT012I)



Servo drives in size E (rated power: 5.0 kW to 7.5 kW): SV660PT0171, SV660PT0211, and SV660PT0261

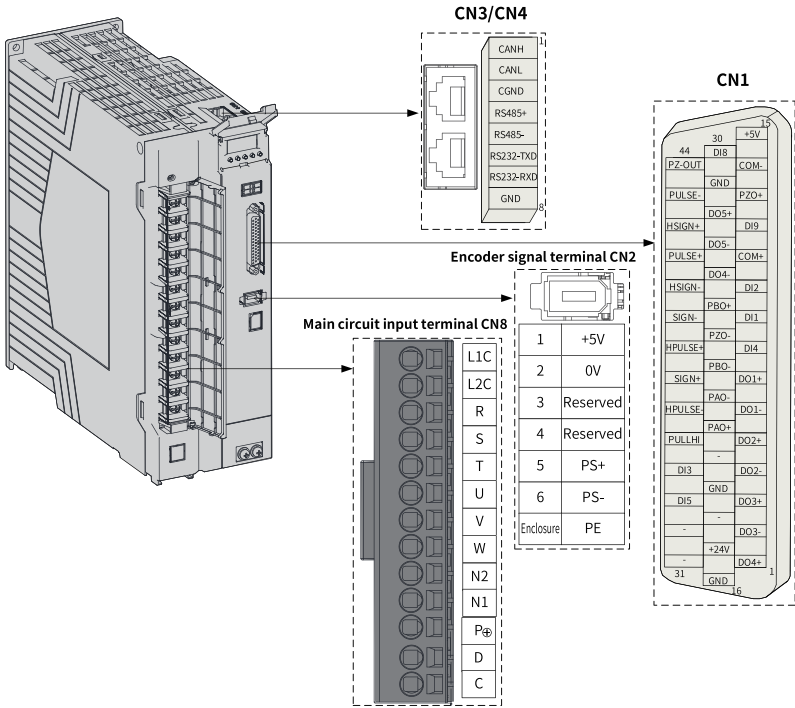

Figure 3-10 Terminal pin layout of servo drives in size E

### 3.4.1 Main Circuit Terminal Pin Layout

Servo drives in size A (rated power: 200 W to 400 W): SV660PS1R6I and SV660PS2R8I

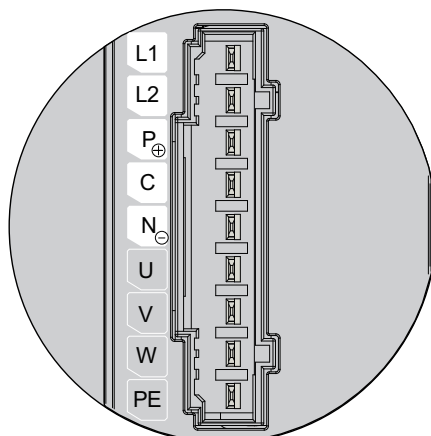

Figure 3-11 Main circuit terminal pin layout of servo drives in size A

Table 3-1 Description of main circuit terminal pins of servo drives in size A

No.	Name	Description
1	L1, L2 (power input terminals)	See the nameplate for the rated voltage class.
2	P $\oplus$ , N $\ominus$ (DC bus terminals)	Used by the common DC bus for multiple servo drives.
	P $\oplus$ and C (terminals for connecting external regenerative resistor)	If an external regenerative resistor is needed, connect it between terminals P $\oplus$ and C.
3	U, V, W (terminals for connecting the servo motor)	Connected to U, V, and W phases of the servo motor.
4	Motor grounding terminal	Connected to the grounding terminal of the motor for grounding purpose.

### Servo drives in size B (rated power: 750 W): SV660PS5R5I

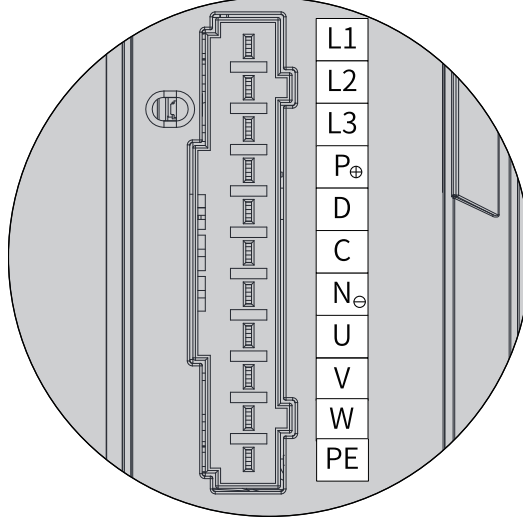

Figure 3-12 Main circuit terminal pin layout of servo drives in size B

Table 3–2 Description of main circuit terminal pins of servo drives in size B

No.	Name	Description
1	L1, L2, L3 (power input terminals)	See the nameplate for the rated voltage class. Note: S5R5 (750 W) models support single-phase 220 V input only, with a 220 V power supply connected between terminals L1 and L2.
2	P⊕, N⊖ (DC bus terminals)	Used by the common DC bus for multiple servo drives.
	P⊕, D, C (terminals for connecting external regenerative resistor)	If an external regenerative resistor is needed, connect it between terminals P⊕ and C. Servo drives in size B are equipped with the built-in regenerative resistor, with terminals P⊕ and D jumpered by default.
3	U, V, W (terminals for connecting the servo motor)	Connected to U, V, and W phases of the servo motor.
4	Motor grounding terminal	Connected to the grounding terminal of the motor for grounding purpose.

## Servo drives in size C and size D (rated power: 1.0 kW to 1.5 kW): SV660PS7R6I and SV660PS012I

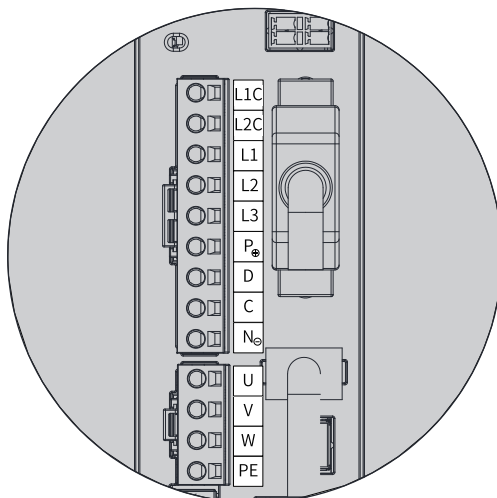

Figure 3-13 Main circuit terminal pin layout of servo drives in size C (SV660PS7R6I) and size D (SV660PS012I)

Table 3-3 Description of main circuit terminal pins of servo drives in size C (SV660PS7R6I) and size D (SV660PS012I)

No.	Name	Description
1	L1C, L2C (control circuit power input terminals)	See the nameplate for the rated voltage class.
2	L1, L2, L3 (main circuit power input terminals)	See the nameplate for the rated voltage class.
3	P⊕, N⊖ (DC bus terminals)	Used by the common DC bus for multiple servo drives.
	P⊕, D, C (terminals for connecting external regenerative resistor)	If an external regenerative resistor is needed, connect it between terminals P⊕ and C. Servo drives in size C and size D are equipped with the built-in regenerative resistor, with terminals P⊕ and D jumpered by default.

No.	Name	Description
4	U, V, W (terminals for connecting the servo motor)	Connected to U, V, and W phases of the servo motor.
5	Motor grounding terminal	Connected to the grounding terminal of the motor for grounding purpose.

**Servo drives in size C and size D (rated power: 1.0 kW to 3.0 kW): SV660PT3R5I, SV660PT5R4I, SV660PT8R4I, and SV660PT012I**

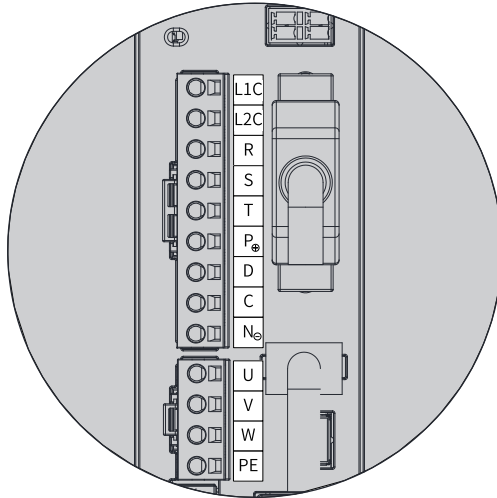

Figure 3-14 Main circuit terminal pin layout of servo drives in size C (SV660PT3R5I, SV660PT5R4I) and size D (SV660PT8R4I, SV660PT012I)

Table 3-4 Description of main circuit terminal pins of servo drives in size C (SV660PT3R5I, SV660PT5R4I) and size D (SV660PT8R4I, SV660PT012I)

No.	Name	Description
1	L1C, L2C (control circuit power input terminals)	See the nameplate for the rated voltage class.
2	R, S, T (main circuit power input terminals)	See the nameplate for the rated voltage class.

No.	Name	Description
3	P $\oplus$ , N $\ominus$ (DC bus terminals)	Used by the common DC bus for multiple servo drives.
	P $\oplus$ , D, C (terminals for connecting external regenerative resistor)	If an external regenerative resistor is needed, connect it between terminals P $\oplus$ and C. Servo drives in size C and size D are equipped with the built-in regenerative resistor, with terminals P $\oplus$ and D jumpered by default.
4	U, V, W (terminals for connecting the servo motor)	Connected to U, V, and W phases of the servo motor.
5	Motor grounding terminal	Connected to the grounding terminal of the motor for grounding purpose.

**Servo drives in size E (rated power: 5.0 kW to 7.5 kW): SV660PT017I, SV660PT021I, and SV660PT026I**

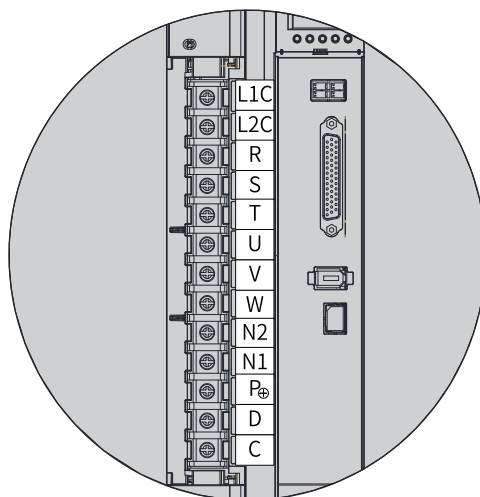
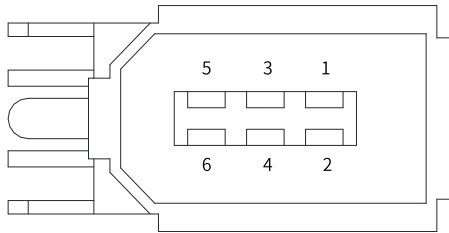

Figure 3-15 Main circuit terminal pin layout of servo drives in size E

Table 3-5 Description of main circuit terminal pins of servo drives in size E

No.	Name	Description
1	L1C, L2C (control circuit power input terminals)	See the nameplate for the rated voltage class.
2	R, S, T (main circuit power input terminals)	See the nameplate for the rated voltage class.
3	U, V, W (terminals for connecting the servo motor)	Connected to U, V, and W phases of the servo motor.
4	N2, N1 Terminals for connecting external reactor	Terminals N1 and N2 are jumpered by default. To suppress harmonics in the power supply, remove the jumper between terminals N1 and N2 first and connect an external DC reactor between terminals N1 and N2.
5	P⊕, D, C (terminals for connecting external regenerative resistor)	If an external regenerative resistor is needed, connect it between terminals P⊕ and C. Servo drives in size E are equipped with the built-in regenerative resistor, with terminals P⊕ and D jumpered by default.

### 3.4.2 Description of Encoder Terminal (CN2)



Encoder signal terminal CN2

Figure 3-16 Encoder terminal pin layout

Table 3-6 Description of encoder terminal pins

No.	Name	Description
1	+5V	5 V power supply
2	0V	-
3	Reserved	-
4	Reserved	-

No.	Name	Description
5	PS+	Encoder signal
6	PS-	
Enclosure	PE	Shield

### 3.4.3 Description of the Control Terminal (CN1)

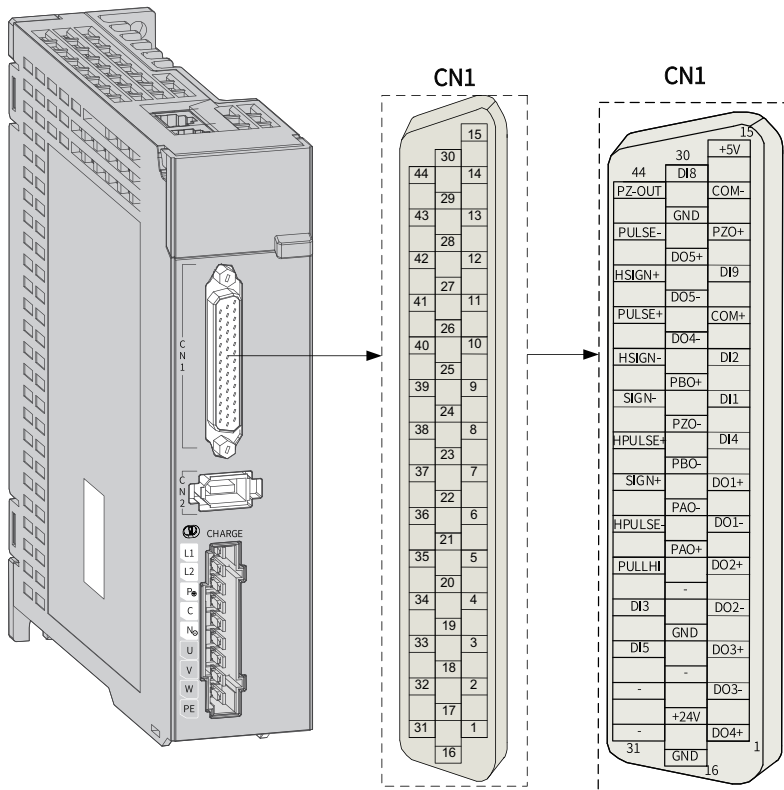

Figure 3-17 Control terminal pin layout of servo drives in sizes A and B



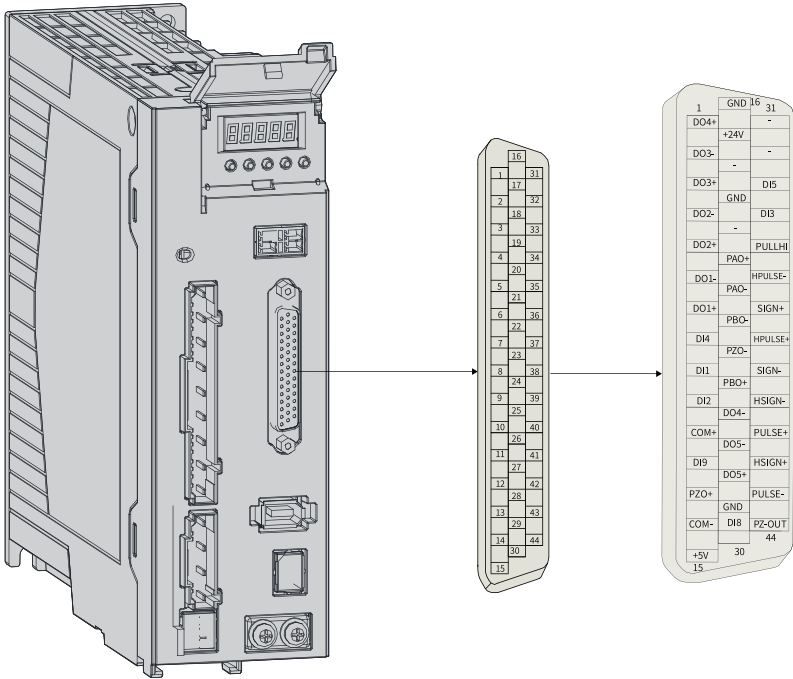

Figure 3-18 Control terminal pin layout of servo drives in sizes C, D, and E

**Note**

- CN1: Plastic housing of plug on cable side: DB25P (manufacturer: SZTDK), black housing Core: HDB44P male solder (manufacturer: SZTDK)
- It is recommended to use cables of 24AWG to 26AWG.
- Use shielded cables as signal cables, with both ends of the shielded cable grounded.

Table 3-7 Description of position reference input signals

Signal Name	Pin No.	Function		
Position reference	PULSE+	41	Low-speed pulse reference input mode: <ul style="list-style-type: none"> <li>• Differential drive input</li> <li>• Open-collector</li> </ul>	Pulse input form: <ul style="list-style-type: none"> <li>• Direction+Pulse</li> <li>• Quadrature pulse of phases A and B</li> <li>• CW/CCW pulse</li> </ul>
	PULSE-	43		
	SIGN+	37		
	SIGN-	39	High-speed input pulse reference	
	HPULSE+	38		
	HPULSE-	36		
	HSIGN+	42	High-speed position reference sign	
HSIGN-	40			

Table 3-8 Description of DI/DO signals

Signal Name	Default Function	Pin No.	Function	
General	DI1	P-OT	9	Positive limit switch
	DI2	N-OT	10	Negative limit switch
	DI3	INHIBIT	34	Pulse inhibit
	DI4	ALM-RST	8	Alarm reset (edge-triggered)
	DI5	S-ON	33	Servo ON
	DI8	HomeSwitch	30	Home switch
	DI9	Reserved	12	-
	+24V		17	Internal 24 V power supply, voltage range: 20 V to 28 V, maximum output current: 200 mA
	COM-		14	
	COM+		11	Common terminal of DI terminals
	DO1+	S-RDY+	7	Servo ready
	DO1-	S-RDY-	6	
	DO2+	COIN+	5	Positioning completed
	DO2-	COIN-	4	
	DO3+	ZERO+	3	Zero speed
	DO3-	ZERO-	2	
	DO4+	ALM+	1	Fault output
	DO4-	ALM-	26	
DO5+	HomeAttain+	28	Homing completed	
DO5-	HomeAttain-	27		

Table 3-9 Specifications of encoder frequency-division output signals

Signal Name	Default Function	Pin No.	Function	
General	PAO+	21	Phase A frequency-division output signal	Quadrature frequency-division pulse output signals of phases A and B
	PAO-	22		
	PBO+	25	Phase B frequency-division output signal	
	PBO-	23		
	PZO+	13	Phase Z frequency-division output signal	Home pulse output signal
	PZO-	24		
	PZ-OUT	44	Phase Z frequency-division output signal	Home pulse open-collector output signal
	GND	29	Home pulse open-collector output signal ground	
	+5V	15	Internal 5 V power supply, maximum output current: 200 mA	
	GND	16		
	PE	Enclosure	-	

### 3.4.4 Description of Communication Terminals (CN3/CN4)

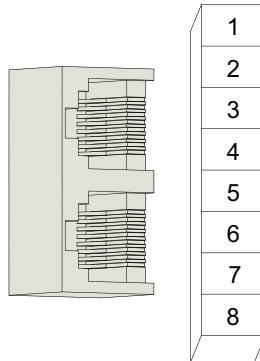

Table 3-10 Description of communication terminal pins

Pin No.	Assignment	Description
1	CANH	CAN communication port
2	CANL	
3	CGND	CAN communication GND

Pin No.	Assignment	Description
4	RS485+	RS485 communication port
5	RS485-	
6	RS232-TXD	RS232 transmitting end, connected to the receiving end of the host controller
7	RS232-RXD	RS232 receiving end, connected to the transmitting end of the host controller
8	GND	Ground
Enclosure	PE	Shield

## 3.5 Connecting the Power supply (RST)

### 3.5.1 Wiring Precautions

- Do not connect the input power supply cables to the output terminals U, V, and W. Failure to comply will damage the servo drive.
- When cables are bundled in a duct, the cooling effect will be deteriorated. In this case, take the permissible current reduction ratio into account.
- When the temperature inside the cabinet exceeds the temperature limit of the cable, it is recommended to replace with Teflon cables featuring a higher temperature limit. As the surface of regular cables may be easily hardened and cracked under a low temperature, take thermal insulation measures for cables laid in a low-temperature environment.
- The bending radius of a cable must be 10 times more than its outer diameter to prevent the internal conductor from breaking due to long-time bending.
- Do not bundle power cables and signal cables together or route them through the same duct. Power cables and signal cables must be separated by at least 30 cm to prevent interference.
- High voltage may be still present in the servo drive after the power supply is switched off. Do not touch the power supply terminals within 15 minutes after power-off.
- Do not switch on/off the power supply frequently. If the power supply is switched on or off frequently within 1s, Er.740/Er.136/Er.430 may occur (see Chapter "Troubleshooting" in SV660P Series Servo Drive Commissioning Guide for details). In this case, power on the servo drive again after waiting for the specified ON/OFF interval. If frequent ON/OFF control is needed, keep an ON/OFF interval of at least 1 min.

The servo drive carries a capacitor in the power supply part, and this capacitor will be charged with a high current for 0.2s upon power-on. Turning on/off the power supply frequently degrades the performance of main circuit components inside the servo drive.

- Use a grounding cable of the same cross-sectional area as the main circuit cable. If the cross-sectional area of the main circuit cable is less than  $1.6 \text{ mm}^2$ , use a grounding cable with a cross-sectional area of  $2.0 \text{ mm}^2$ .
- Do not power on the servo drive if terminal screws or cables are loose. Failure to comply may lead to a fire.

### 3.5.2 Main Circuit Wiring Requirements

Servo drive power input cables and motor cables may generate strong electromagnetic interference. To prevent the electromagnetic interference incurred by long-distance parallel routing and coupling between disturbing cables and control cables, keep a clearance of at least 30 cm between main circuit cables and signal cables. Main circuit cables include the RST cable, UVW cable, DC bus, and braking cable. Signal cables include the I/O signal cable, communication cable, and encoder cable.

Cable ducts must be connected and grounded properly. Aluminum cable ducts can be used to ensure equipotentiality of the device. The filter, servo drive, and motor must be properly connected to systems (machines or devices), with spraying protection applied at the installation part and the conductive metal kept in full contact.

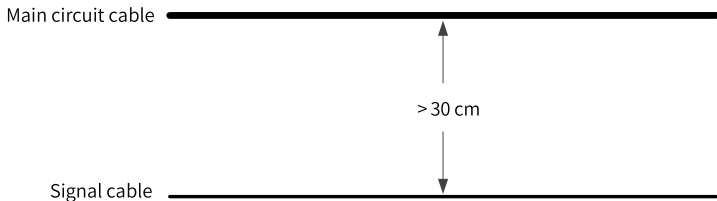

Figure 3-19 Cable layout

#### Wiring requirements

The wiring mode compliant with the Low Voltage Directive is supported.

- Terminals P $\oplus$ , C, and N $\ominus$  are used to connect optional parts. Do not connect these terminals to an AC power supply.
- To protect the main circuit, separate and cover the surface that may come into contact with the main circuit.
- Do not allow unwanted objects to enter the wiring part of the terminal block.
- Do not solder the twisted conductors.
- The tightening torque may vary with terminals. Tighten terminal screws with the specified tightening torque. You can use a torque screwdriver, torque ratchet, or torque wrench to tighten terminal screws.

- When using an electric screwdriver to tighten terminal screws, set the electric screwdriver to low speed to prevent damage to the terminal screws.
- Tighten the terminal screws with an angle not higher than 5°. Failure to comply may damage the terminal screws.

### 3.5.3 Recommended Cable Specifications and Models

Table 3-11 Input/Output current specifications of the servo drive

Servo Drive Model****I		Rated Input Current (A)	Rated Output Current (A)	Maximum Output Current (A)
Single-phase 220 V				
Size A	S1R6	2.3	1.6	5.8
	S2R8	4	2.8	10.1
Size B	S5R5	7.9	5.5	16.9
Size C	S7R6	9.6	7.6	23
Size D	S012	12.8	11.6	32
Three-phase 220 V				
Size C	S7R6	5.1	7.6	23
Size D	S012	8	11.6	32
Three-phase 380 V				
Size C	T3R5	2.4	3.5	11
	T5R4	3.6	5.4	14
Size D	T8R4	5.6	8.4	20
	T012	8	11.9	29.75
Size E	T017	12	16.5	41.25
	T021	16	20.8	52.12
	T026	21	25.7	64.25

Table 3-12 Recommended main circuit terminal cables and tightening torque

Servo Drive Series	Servo Drive Model	Rated Input Current (A)	Recommended PVC Cable Model (at 40°C)			
			L1, L2/L1, L2, L3 (mm <sup>2</sup> )	R, S, T (mm <sup>2</sup> )	Cable Lug (mm <sup>2</sup> )	Tightening Torque (N·m)
Single-phase 220 V						
Size A	SV660PS1 R6I	2.3	0.75	-	-	-
	SV660PS2 R8I	4	0.75	-	-	-
Size B	SV660PS5 R5I	7.9	0.75	-	-	-

Servo Drive Series	Servo Drive Model	Rated Input Current (A)	Recommended PVC Cable Model (at 40°C)			
			L1, L2/L1, L2, L3 (mm <sup>2</sup> )	R, S, T (mm <sup>2</sup> )	Cable Lug (mm <sup>2</sup> )	Tightening Torque (N·m)
Size C	SV660PS7 R6I	9.6	1	-	-	-
Size D	SV660P S012I	12.8	1.5	-	-	-
Three-phase 220 V						
Size C	SV660PS7 R6I	5.1	0.75	-	-	-
Size D	SV660P S012I	8	0.75	-	-	-
Three-phase 380 V						
Size C	SV660PT3 R5I	2.4	-	0.75	-	-
	SV660PT5 R4I	3.6	-	0.75	-	-
Size D	SV660PT8 R4I	5.6	-	0.75	-	-
	SV660P T012I	8	-	0.75	-	-
Size E	SV660P T017I	12	-	1.5	1.5	1.36
	SV660P T021I	16	-	2.5	2.5	1.36
	SV660P T026I	21	-	4	4	1.36

Table 3-13 Specifications of motor output cables

MS1H1/H4 05B-10C (Applicable to Motors with Rated Output of 50 W to 1 kW)			
Cable type	Regular cable	Flexible cable	Oil-resistant shielded flexible cable
Cable model	S6-L-M/B***-X.X	S6-L-M/B***-X.X-T	S6-L-M/B***-X.X-TS
Cable specifications	UL2517 (rated temperature: 105°C) 4Ex20AWG+2Cx24AWG	UL2517 (rated temperature: 105°C) 4Ex20AWG+2Cx24AWG	UL2517 (rated temperature: 105°C) 4Ex20AWG+2Cx24AWG
	Power cable: 20AWG (0.52 mm <sup>2</sup> ) Insulation diameter: 1.7 mm	Power cable: 20AWG (0.52 mm <sup>2</sup> ) Insulation diameter: 1.7 mm	Power cable: 20AWG (0.52 mm <sup>2</sup> ) Insulation diameter: 1.7 mm
	Brake cable: 24AWG (0.205 mm <sup>2</sup> ) Insulation diameter: 1.1 mm	Brake cable: 24AWG (0.205 mm <sup>2</sup> ) Insulation diameter: 1.1 mm	Brake cable: 24AWG (0.205 mm <sup>2</sup> ) Insulation diameter: 1.1 mm
Sheath diameter	6.5±0.2 mm		



MS1H1/H4 05B-10C (Applicable to Motors with Rated Output of 50 W to 1 kW)			
Internal structure and conductor colors			
Fill in "X.X" in the model number with designated cable length.			

Table 3-14 Specifications of motor output cables







MS1H2 10C-50C (Applicable to Motors with Rated Output of 1 kW to 5 kW)/MS1H3 85B-18C (Applicable to Motors with Rated Output of 850 W to 1.8 kW)			
Cable type	Regular cable	Flexible cable	Oil-resistant shielded flexible cable
Cable model	S6-L-M/B***-X.X	S6-L-M/B***-X.X-T	S6-L-M/B***-X.X-TS
Cable specifications	UL2586 (rated temperature: 105°C) 4Ex16AWG, 2Cx18AWG	UL2586 (rated temperature: 105°C) 4Ex16AWG, 2Cx18AWG	UL2586 (rated temperature: 105°C) 4Ex16AWG, 2Cx18AWG
	Power cable: 16AWG (1.31 mm <sup>2</sup> ) Insulation diameter: 3.1 mm Brake cable: 18AWG (0.823 mm <sup>2</sup> ) Insulation diameter: 2.0 mm	Power cable: 16AWG (1.31 mm <sup>2</sup> ) Insulation diameter: 3.25 mm Brake cable: 18AWG (0.823 mm <sup>2</sup> ) Insulation diameter: 2.15 mm	Power cable: 16AWG (1.31 mm <sup>2</sup> ) Insulation diameter: 3.25 mm Brake cable: 18AWG (0.823 mm <sup>2</sup> ) Insulation diameter: 2.15 mm
Sheath diameter	9.5±0.3 mm (main circuit)	10.0±0.3 mm (main circuit)	10.5±0.3 mm (main circuit)
Internal structure and conductor colors			
Fill in "X.X" in the model number with designated cable length.			



Table 3-15 Specifications of motor output cables

MS1H3 29C-75C (Applicable to Motors with Rated Output of 2.9 kW to 7.5 kW)			
Cable type	Regular cable	Flexible cable	Oil-resistant shielded flexible cable
Cable model	S6-L-M/B***-X.X	S6-L-M/B***-X.X-T	S6-L-M/B***-X.X-TS
Cable specifications	UL2586 (rated temperature: 105°C) 4Ex12AWG, 2Cx18AWG	UL2586 (rated temperature: 105°C) 4Ex12AWG, 2Cx18AWG	UL2586 (rated temperature: 105°C) 4Ex12AWG, 2Cx18AWG
	Power cable: 12AWG (3.31 mm <sup>2</sup> ) Insulation diameter: 4.1 mm	Power cable: 12AWG (3.31 mm <sup>2</sup> ) Insulation diameter: 4.2 mm	Power cable: 12AWG (3.31 mm <sup>2</sup> ) Insulation diameter: 4.2 mm
	Brake cable: 18AWG (0.823 mm <sup>2</sup> ) Insulation diameter: 2.0 mm	Brake cable: 18AWG (0.823 mm <sup>2</sup> ) Insulation diameter: 2.15 mm	Brake cable: 18AWG (0.823 mm <sup>2</sup> ) Insulation diameter: 2.15 mm
Sheath diameter	12.2±0.4 mm (main circuit)	12.5±0.4 mm (main circuit)	13.2±0.4 mm (main circuit)
Internal structure and conductor colors			
Fill in "X.X" in the model number with designated cable length.			

**Cable selection**

To comply with the EMC standards, use shielded cables. Shielded cables are divided into three-conductor shielded cables and four-conductor shielded cables, as shown in the following figure.

If the conductivity of the three-conductor cable shield is insufficient, add an extra PE cable or use a four-conductor shielded cable, with one conductor of which being PE cable. The cable shield must be made of co-axial copper braids with a weaving density larger than 90% to enhance the shielding and conductivity performance and suppress radio frequency interference.

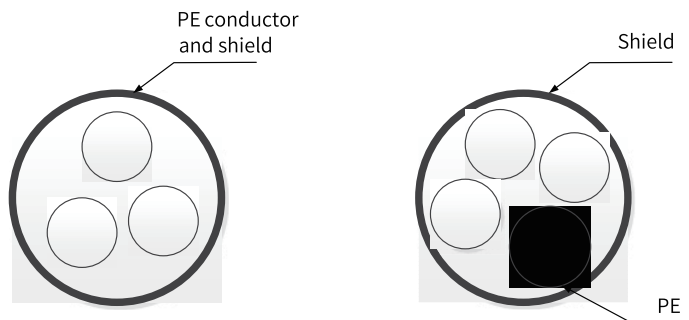

Figure 3-20 Recommended power cables

Observe national or regional regulations when selecting cable dimensions. The IEC cable must meet the following requirements:

- Complying with standards EN 60204-1 and IEC 60364-5-52
- PVC cable with copper conductors
- Allowing the cable surface temperature to be lower than or equal to 70°C under an ambient temperature of 40°C (When the ambient temperature exceeds 40°C, contact Inovance.)

Requirements for UL cable selection are described in "[Cable requirements](#)" on page 150.

---

## Note

If the recommended cable specifications for peripheral devices or optional parts exceed the applicable cable specification range, contact Inovance.

---

### 3.5.4 Wiring of the Power Supply

- Single-phase 220 V models: SV660PS1R6I, SV660PS2R8I, SV660PS5R5I, SV660PS7R6I, and SV660PS012

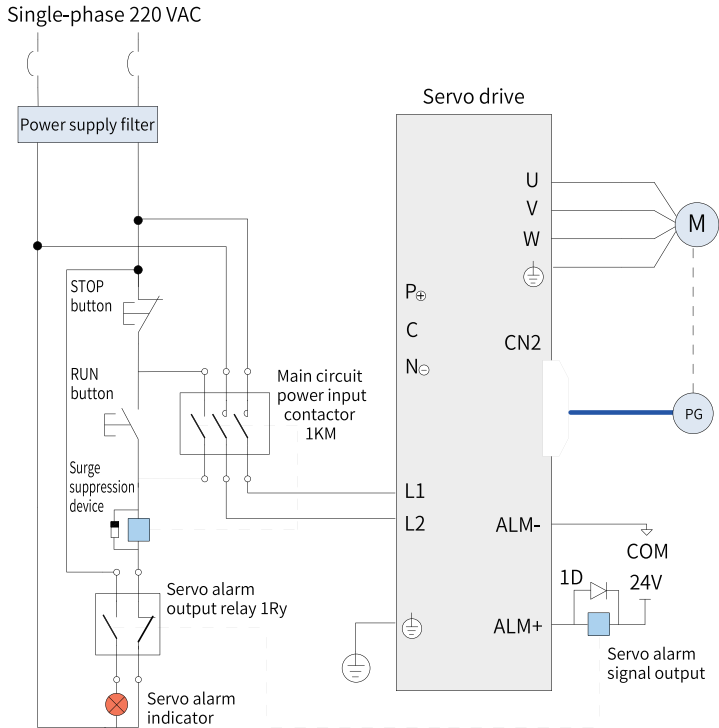

Figure 3-21 Main circuit wiring of single-phase 220 V models

## Note

- 1KM: Electromagnetic contactor; 1Ry: Relay; 1D: Flywheel diode
- The DO is set as alarm output (ALM+/-). When the servo drive alarms, the power supply is cut off automatically. The built-in regenerative resistor is not available in models SV660PS1R6 and SV660PS2R8. For these models, you can connect an external regenerative resistor between terminals P $\oplus$  and C as needed.
- Three-phase 220 V models: SV660PS7R6I,SV660PS012I

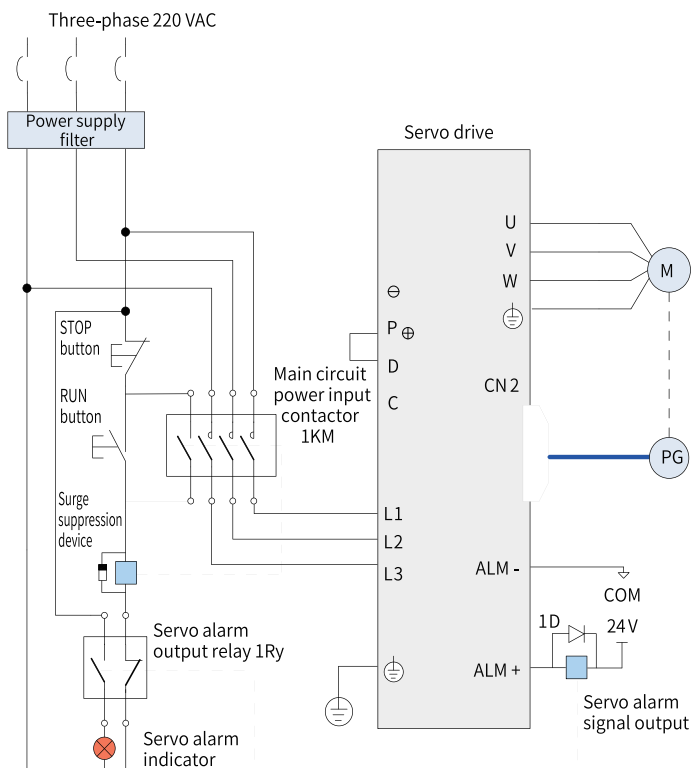

Figure 3-22 Main circuit wiring of three-phase 220 V models

## Note

- 1KM: Electromagnetic contactor; 1Ry: Relay; 1D: Flywheel diode
  - The DO is set as alarm output (ALM+/-). When the servo drive alarms, the power supply is cut off automatically and the alarm indicator lights up.
- 
- Three-phase 380 V models: SV660PT3R5I, SV660PT5R4I, SV660PT8R4I, SV660PT012I, SV660PT021I, SV660PT026I

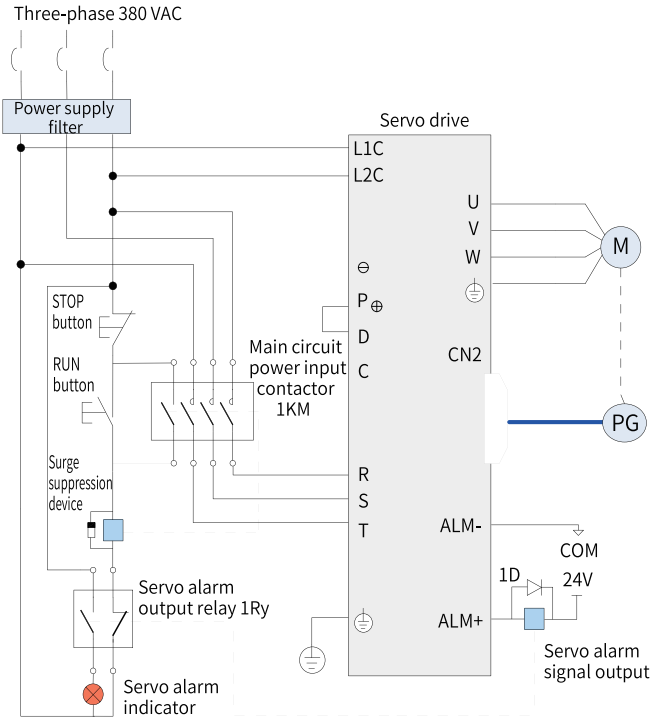

Figure 3-23 Main circuit wiring of three-phase 380 V models

**Note**

- 1KM: Electromagnetic contactor; 1Ry: Relay; 1D: Flywheel diode
- The DO is set as alarm output (ALM+/-). When the servo drive alarms, the power supply is cut off automatically and the alarm indicator lights up.

**3.5.5 Wiring of External EMC Filter**

Install the filter near the input terminals of the drive. The cable between the filter and the drive must be shorter than 30 cm. Connect the grounding terminal of the filter together with the grounding terminal of the drive. Ensure the filter and the drive are installed onto the same conductive mounting surface that is connected to the main grounding of the control cabinet.

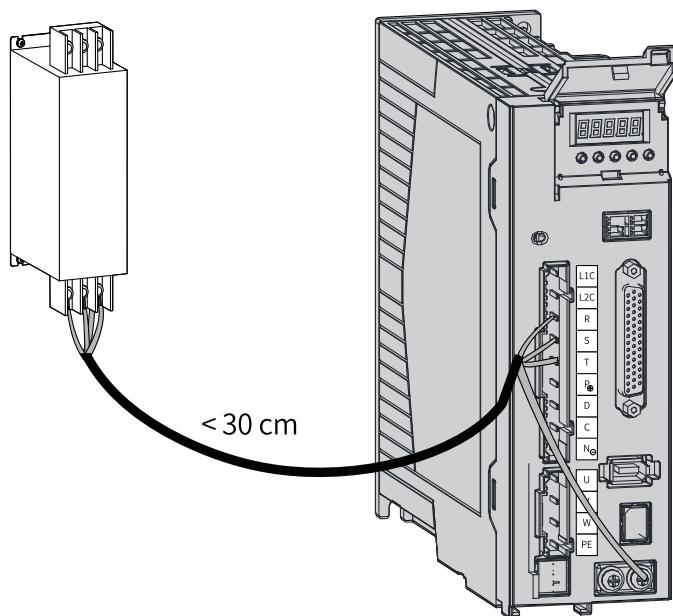

Figure 3-24 Installing the filter

Keep the lead wire of the motor cable shield as short as possible, with its width (b in the following figure) not shorter than  $1/5$  of its length (a in the following figure).

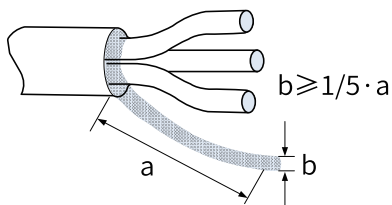

Figure 3-25 Lead-out of the motor cable shield

### 3.5.6 Grounding and Wiring

Observe the following requirements to ensure a proper grounding of the servo drive.

 **Warning**

- To prevent electric shocks, ground the grounding terminal properly. Observe related national or regional regulations during wiring.
  - To prevent electric shocks, ensure the protective grounding conductor complies with technical specifications and local safety standards. Keep the length of the grounding cable as short as possible. As the leakage current of the equipment may exceed 3.5 mA, use a copper protective grounding conductor with a cross-sectional area of at least 10 mm<sup>2</sup> according to standard EN 61800-5-1, or use two protective grounding conductors with the same specification.
  - Use a grounding cable that complies with electrical device technical standards and keep the length of the grounding cable as short as possible. Failure to comply will lead to unstable potential in the grounding terminals away from the grounding point due to leakage current, resulting in an electric shock.
- 

 **Caution**

- For use of multiple drives, observe all the grounding instructions for the drive. Improper grounding of the device will lead to malfunction of the drive and the device.
  - Do not share the same grounding cable with other devices (such as welding machines or high-current electrical devices). Improper grounding of the device will lead to drive or device faults caused by electrical interference.
  - For use of multiple drives, observe all the grounding instructions for the drive. Improper grounding of the device will lead to malfunction of the drive and the device.
  - For drives equipped with optional VDR grounding screws, remove the grounding screw before voltage resistance test. Failure to comply may cause the drive to fail the test.
- 

## Grounding requirements

Observe the following requirements to ensure a proper grounding of the drive.

- The protective grounding conductor must be a yellow/green copper conductor. Do not connect the protective grounding conductor to a switching device (such as a circuit breaker) in serial.
- Ground the grounding terminal properly. Improper grounding will lead to equipment malfunction or damage.
- Do not connect the grounding terminal to the N terminal of the neutral wire of the power supply.

- It is recommended to install the drive to a conductive metal surface. Ensure the whole conductive bottom of the drive is connected properly to the mounting face.
- Tighten the grounding screw with specified tightening torque to prevent the protective grounding conductor from being secured improperly.

## Single-drive grounding

Installation of an individual drive:

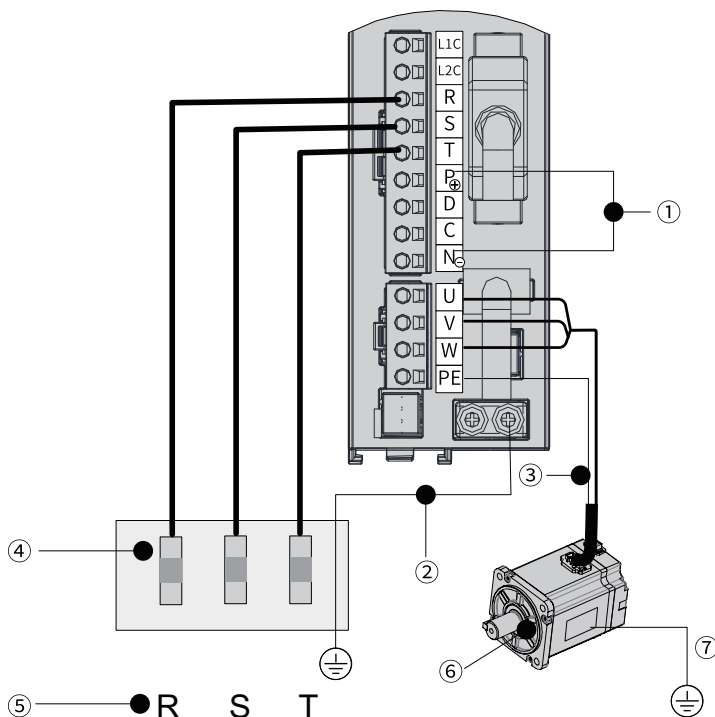

Table 3-16 Single-drive grounding

No.	Description
①	Do not ground the DC bus terminal or the regenerative resistor terminal.
②	Connect the PE cable on the input power supply end to the input PE terminal of the servo drive.
③	Connect the output PE terminal of the servo drive to the motor output cable shield.
④	Input protection (fuse or circuit breaker) Connect the lower end of the fuse to the filter.
⑤	Input power supply
⑥	Three-phase motor



No.	Description
⑦	Ground the motor enclosure.
Note: The main circuit terminal layout varies with different models and is subject to the physical product.	

### Multi-drive grounding

Side-by-side installation of multiple drives:

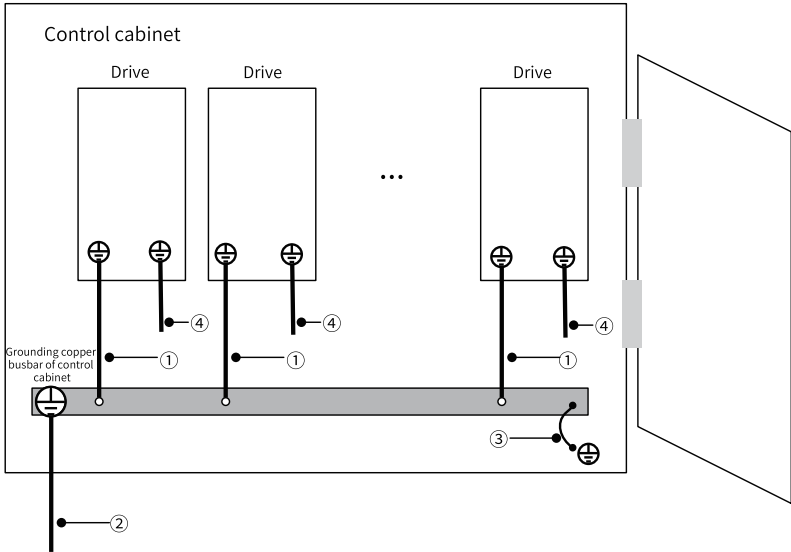

Table 3-17 Multi-drive grounding

No.	Description
①	Connect the main circuit input PE terminal to the grounding copper busbar of the control cabinet through the protective grounding conductor.
②	Connect the PE cable on the input power supply end to the grounding copper busbar of the control cabinet.
③	Connect the grounding copper busbar of the control cabinet to the metal enclosure of the control cabinet through the protective grounding conductor.
④	Connect the motor output cable shield to the output PE terminal of the drive.

### Cabinet system grounding

The most effective measure to suppress disturbance inside the cabinet is to isolate the disturbance source from the disturbed devices during installation. Divide the control cabinet into several EMC areas or several cabinets based on the intensity of

the disturbance source, and install devices into corresponding areas based on the requirements listed in the following table.

Table 3-18 Wiring requirements

No.	Wiring requirements
1	Install the control devices and drive devices into two separate cabinets.
2	For installation involving multiple cabinets, use the grounding cable with a cross-sectional area of at least 16 mm <sup>2</sup> to connect the cabinets. This is to ensure equipotentiality between the cabinets.
3	For installation involving only one cabinet, install different devices into different areas inside the cabinet according to the signal intensity.
4	Apply equipotential bonding to devices in different areas inside the cabinet.
5	Shield all the communication (such as RS485) cables and signal cables routed out from the control cabinet.
6	Install the power input filter inside the cabinet to a place near the input interface of the cabinet.
7	Apply spray coating to all the grounding points in the cabinet.

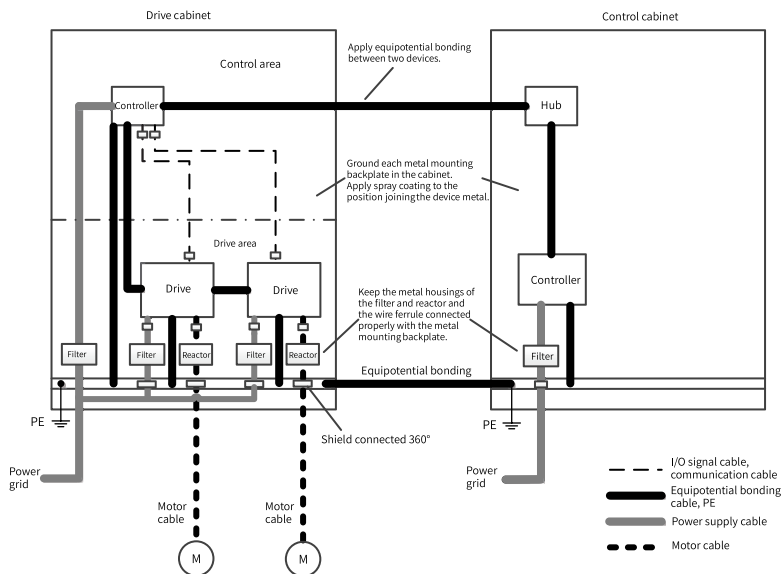

Figure 3-26 Recommended wiring of the cabinet system

## Recommended grounding cable lug for the main circuit

Table 3-19 Recommended grounding cable lug for the main circuit

Servo Drive Model SV660P****I		PE
Size A	SV660PS1R6I	TVR 2-4
	SV660PS2R8I	TVR 2-4
Size B	SV660PS5R5I	TVR 2-4
Size C	SV660PS7R6I	TVR 2-4
	SV660PT3R5I	TVR 2-4
	SV660PT5R4I	TVR 2-4
Size D	SV660PS012I	TVR 2-4
	SV660PT8R4I	TVR 2-4
	SV660PT012I	TVR 2-4
Size E	SV660PT017I	TVR 2-4
	SV660PT021I	TVR 2-4
	SV660PT026I	TVR 2-4

The following table lists the data for recommended cable lugs (manufacturer: Suzhou Yuanli Metal Enterprise Co., Ltd) for your reference.

Table 3-20 Dimension drawing of the grounding cable lug

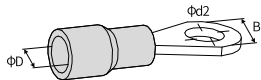
Model		D (mm)	d2 (mm)	B (mm)	Dimension Drawing
TVR	2-4	4.5	4.3	8.5	

## 3.6 Connecting the Motor (UVW)

- The wiring diagram for a terminal-type motor is shown in the following figure.

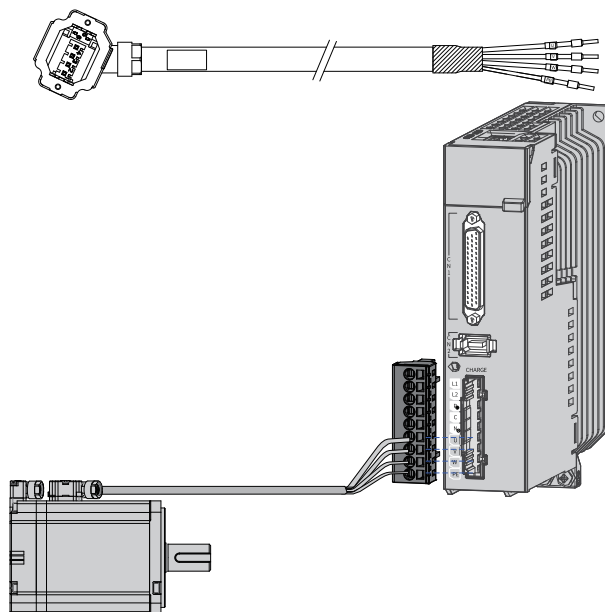
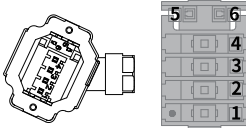

Figure 3-27 Wiring between the servo drive and the motor

Table 3-21 Description of the power cable connector (motor side)

Applicable Motor Flange Size [1]	Outline Drawing of the Connector	Terminal Pin Layout		
		Pin No.	Signal Name	Color
Terminal-type motor: 40 (Z series) 60 (Z series) 80 (Z series)	 Black 6-pin connector	1	PE	Yellow/ Green
		2	W	Red
		3	V	Black
		4	U	White
		5	Brake (polarity insensitive)	Brown
		6		Blue

## Note

- [1] The flange size refers to the width of the mounting flange.
  - Power cable colors are subject to the actual product. All cable colors mentioned in this guide refer to Inovance cable colors.
- 
- The connection diagram for a lead wire-type motor is shown in the following figure.

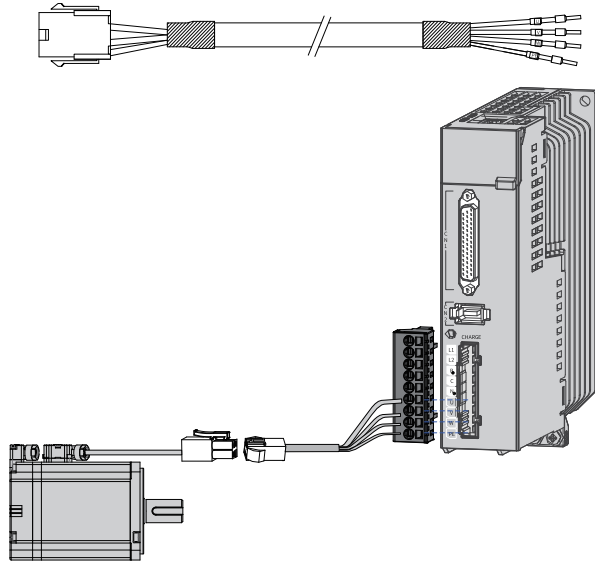
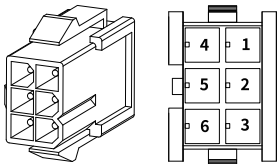

Figure 3-28 Wiring between the servo drive and the motor

Table 3-22 Description of the power cable connector (motor side)

Applicable Motor Flange Size <sup>[1]</sup>	Outline Drawing of the Connector	Terminal Pin Layout		
		Pin No.	Signal Name	Color
Lead wire-type motor 40 (Z-S series) 60 (Z-S series) 80 (Z-S series)	 <p>Black 6-pin connector Recommendation: Plastic housing: MOLEX-50361736 Terminal: MOLEX-39000061</p>	1	U	White
		2	V	Black
		4	W	Red
		5	PE	Yellow/ Green
		3	Brake (polarity insensitive)	Brown
		6		Blue

**Note**

- [1] The flange size refers to the width of the mounting flange.
- Power cable colors are subject to the actual product. All cable colors mentioned in this guide refer to Inovance cable colors.
- The following table describes the connector for high-power motor power cables.

Table 3–23 Description of the power cable connector (motor side)

Applicable Motor Flange Size <sup>[1]</sup>	Outline Drawing of the Connector	Terminal Pin Layout		
		Pin No.	Signal Name	Color
100 130	 <p>20-18 aviation connector</p> <p>MIL-DTL-5015 series 3108E20-18S aviation connector</p>	B	U	Blue
		I	V	Black
		F	W	Red
		G	PE	Yellow/Green
		C	Brake (polarity insensitive)	Red
		E		Black

Table 3–24 Description of the power cable connector (motor side)

Applicable Motor Flange Size <sup>[1]</sup>	Outline Drawing of the Connector	Terminal Pin Layout		
		Pin No.	Signal Name	Color
180	 <p>20-22 aviation connector</p> <p>MIL-DTL-5015 series 3108E20-22S aviation connector</p>	A	U	Blue
		C	V	Black
		E	W	Red
		F	PE	Yellow/Green
		B	Brake (polarity insensitive)	Red
		D		Black

## Note

- [1] The flange size refers to the width of the mounting flange.
- Power cable colors are subject to the actual product. All cable colors mentioned in this guide refer to Inovance cable colors.

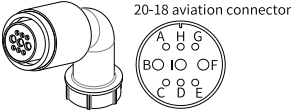
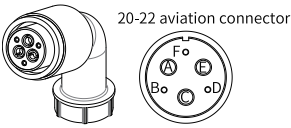
## 3.7 Connecting the Encoder (CN2)

### 3.7.1 Installing the Absolute Encoder Battery Box

The optional S6-C4 battery box contains the following items:

- One plastic body
- One battery (3.6 V, 2600 mAh)
- Terminal block and crimping terminal

## Installing the battery box

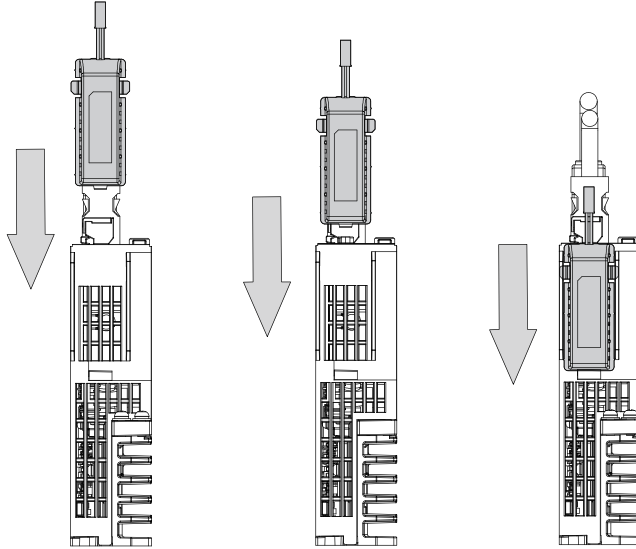
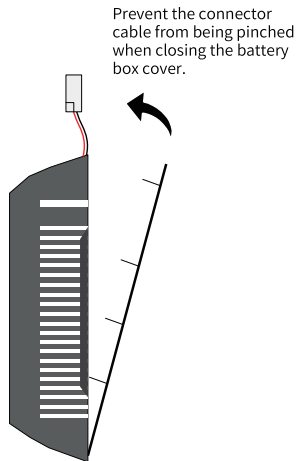

Figure 3-29 Installing the absolute encoder battery box (bottom view)

## Removing the battery box

The battery may generate leakage liquid after long-term operation. Replace the battery every two years. Remove the battery box in steps shown in the preceding figure, but in the reverse order.

When closing the battery box cover, prevent the connector cables from being pinched.



Improper use of the battery may generate liquid leakage which not only corrodes the components but also incurs the risk of battery explosion. Observe the following precautions during use:



- Insert the battery with polarity (+/-) placed correctly.
  - Leaving a battery that has been used for a long time or is no longer useful inside the device may lead to electrolyte leakage. The electrolyte inside the battery is highly corrosive, not only corroding surrounding components but also incurring the risk of short circuit. It is recommended to replace the battery every 2 years.
  - Do not disassemble the battery because the internal electrolyte may spread out and result in personal injury.
  - Do not throw a battery into the fire. Failure to comply may result in an explosion.
  - Do not strip off the battery tube or short circuit the battery. Prevent terminals (+) and (-) of the battery from coming into contact with the metal. Contact with the metal will result in a large current, not only weakening the battery power, but also incurring the risk of explosion due to severe heating.
  - This battery is not rechargeable.
  - Dispose of the retired battery according to local regulations.
- 

### Selecting the battery model

Select an appropriate battery according to the following table.



Table 3-25 Description of the absolute encoder battery

Battery Specifications	Item	Rated Values			Condition
		Minimum Value	Typical Value	Maximum Value	
Output: 3.6 V, 2500 mAh Recommended manufacturer and model: Shenzhen Jieshun, LS14500	External battery voltage (V)	3.2	3.6	5	In standby state <sup>[2]</sup>
	Circuit fault voltage (V)	-	2.6	-	In standby state
	Battery alarm voltage (V)	2.85	3	3.15	-
	Current consumed by the circuit (μA)	-	2	-	In normal operation <sup>[1]</sup>
		-	10	-	In standby state, shaft at standstill
		-	80	-	In standby state, shaft rotating
	Ambient temperature (°C)	0		40	Same as the motor
Storage temperature (°C)	-20		60		

The preceding data is obtained under an ambient temperature of 20°C.

## Note

- [1] During normal operation, the absolute encoder supports one-turn or multi-turn data counting and transceiving. Power on the servo drive after connecting the absolute encoder. The encoder starts data transceiving after a short delay of about 5s upon power-on. The motor speed must be lower than or equal to 10 RPM during transition from the standby state to the operating state (upon power-on). Otherwise, Er.740 (Encoder fault) may occur. In this case, you need to power off and on the servo drive again.
- [2] The "standby state" means the encoder counts the multi-turn data by using the power from the external battery when the servo drive power supply is not switched on. In this case, data transceiving stops.

## Design life of the battery

The following calculation only covers the current consumed by the encoder.

Assume that the drive works normally for T1 in a day, the motor rotates for T2 after the drive is powered off, and the motor stops rotating for T3 after power-off [unit: hour (H)].

Example:

Table 3-26 Design life of the absolute encoder battery

Item	Schedule 1	Schedule 2
Working Days in Different Operating Conditions in 1 Year	313	52
T1 (h)	8	0
T2 (h)	0.1	0
T3 (h)	15.9	24

Capacity consumed in 1 year =  $(8 \text{ h} \times 2 \text{ uA} + 0.1 \text{ h} \times 80 \text{ uA} + 15.9 \text{ h} \times 10 \text{ uA}) \times 313 + (0 \text{ h} \times 2 \text{ uA} + 0 \text{ h} \times 80 \text{ uA} + 24 \text{ h} \times 10 \text{ uA}) \times 52 \approx 70 \text{ mAH}$

Design life = Battery capacity/Capacity consumed in 1 year =  $2600 \text{ mAH}/70 \text{ mAH} = 37.1$  years

### 3.7.2 Connecting the Absolute Encoder Cable

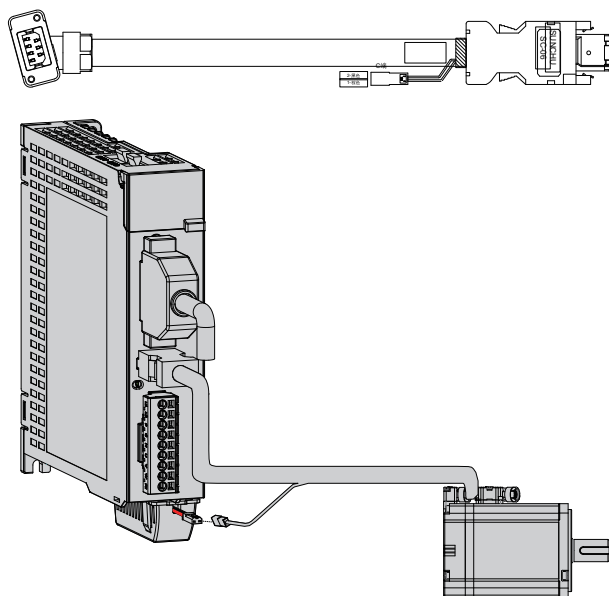
Figure 3-30 Wiring example of absolute encoder signals<sup>[1]</sup>

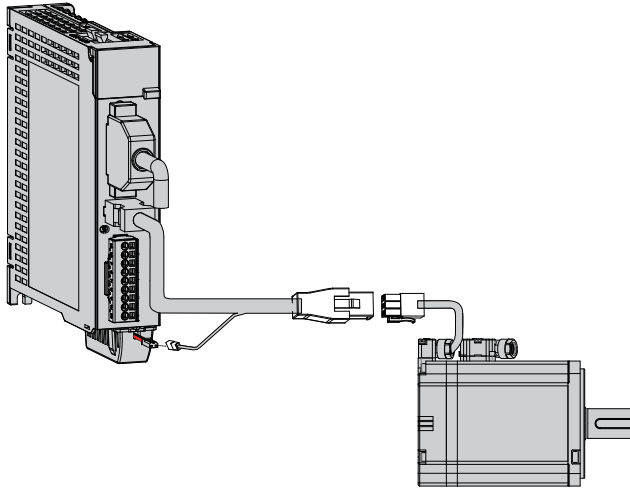

Figure 3-31 Wiring example of absolute encoder signals<sup>[1]</sup>

**Note**

- [1] The preceding figure shows the wiring diagram of the absolute encoder, which is similar to that of an incremental encoder (without a battery box). The cable for the incremental encoder needs to be purchased separately.
- The encoder cable color is subject to the color of the actual product. Cable colors mentioned in this guide all refer to Inovance cables.

Lead wires of the battery box:

Pin No.	Color	Assignment
1	Red	Power supply (+)

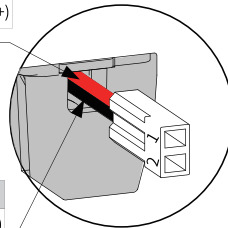

Pin No.	Color	Assignment
2	Black	Power supply (-)

Figure 3-32 Description of the lead wire color of the battery box

## Note

- Store the battery according to the required temperature and ensure reliable contact and sufficient battery power. Failure to comply may result in encoder data loss.
- Model of the battery box (battery included): S6-C4

Table 3-27 Connector of terminal-type motor encoder cable

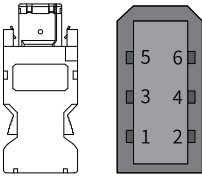
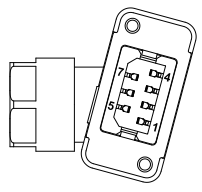
Applicable Motor Flange Size <sup>[1]</sup>	Outline Drawing of the Connector		Terminal Pin Layout			
			Pin No.	Signal Name	Color	Type
Terminal-type motor: 40 60 80	Servo drive side	 <p>6-pin male (The joint face is on the right side.)</p>	1	+5V	Red	Twisted pair
			2	GND	Orange	
			5	PS+	Blue	Twisted pair
			6	PS-	Purple	
			Enclosure	PE	-	-
			Motor side	 <p>7-pin connector</p>	1	PS+
	2	PS-			Purple	
	3	DC+			Brown	Twisted pair
	4	DC-			Black	
	5	+5V			Red	Twisted pair
6	GND	Orange				
7	PE	-			-	

## Note

[1] The flange size refers to the width of the mounting flange.

Table 3-28 Lead wire-type motor encoder cable connector (9-pin connector)

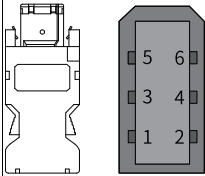
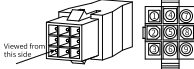
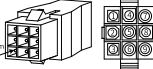
Applicable Motor Flange Size <sup>[1]</sup>	Outline Drawing of the Connector		Terminal Pin Layout			
			Pin No.	Signal Name	Color	Type
Lead wire-type motor 40 60 80	 <p>Connector of the encoder lead wire Connected to CN2 of the servo drive</p>	 <p>Servo drive side</p> <p>6-pin male (The joint face is on the right side.)</p>	1	+5V	Red	Twisted pair
			2	GND	Orange	
			5	PS+	Blue	Twisted pair
			6	PS-	Purple	
			Enclosure	PE	-	-
	 <p>Motor side</p> <p>9-pin connector Recommendation: Plastic housing: AMP 172161-1; Terminal: AMP 770835-1</p>	 <p>Viewed from this side</p>	1	Battery (+)	Brown	Twisted pair
			4	Battery (-)	Black	
			3	PS+	Blue	
			6	PS-	Purple	
			9	+5V	Red	-
8			GND	Orange		
7	Shield	-				

**Note**

[1] The flange size refers to the width of the mounting flange.

Table 3–29 Absolute encoder cable connector (MIL-DTL-5015 series 3108E20-29S aviation connector)

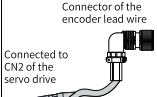
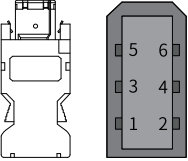
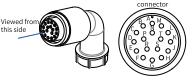
Applicable Motor Flange Size <sup>[1]</sup>	Outline Drawing of the Connector			Terminal Pin Layout			
				Pin No.	Signal Name	Color	Type
100 130 180	 <p>Connector of the encoder lead wire Connected to CN2 of the servo drive</p>	Servo drive side	 <p>6-pin male (The joint face is on the right side.)</p>	1	+5V	Red	Twisted pair
				2	GND	Orange	
				5	PS+	Blue	Twisted pair
				6	PS-	Purple	
				Enclosure	PE	-	-
	Motor side	 <p>Viewed from this side 20-29S aviation connector</p>	Motor side	A	PS+	Blue	Twisted pair
				B	PS-	Purple	
				E	Battery (+)	Brown	-
				F	Battery (-)	Black	
				G	+5V	Red	-
H				GND	Orange		
J	Shield	-	-				

## Note

[1] The flange size refers to the width of the mounting flange.

### 3.7.3 Precautions for Encoder Signal Wiring

- Ground the shield on the drive side and the motor side. Otherwise, the servo drive will report a false alarm.
- Do not connect the cable to "Reserved" terminals.
- Given the voltage drop caused by cable resistance and signal attenuation caused by distributed capacitance, it is recommended to use shielded twisted pair cables of 26AWG or higher (as per standard UL2464) with length no longer than 10 m as the encoder cable.

## Note

It is recommended to use 22AWG...26AWG cables and terminal AMP170359-1 for 10B, 20B, 40B, and 75B series motors. Longer cables require larger cross sectional area. See the following table for details.

Table 3-30 Recommended cables

Cross Sectional Area of the Cable	$\Omega/\text{km}$	Allowable Length (m)
26AWG (0.13 mm <sup>2</sup> )	143	10
25AWG (0.15 mm <sup>2</sup> )	89.4	16
24AWG (0.21 mm <sup>2</sup> )	79.6	18
23AWG (0.26 mm <sup>2</sup> )	68.5	20.9
22AWG (0.32 mm <sup>2</sup> )	54.3	26.4

## Note

If cables above 22AWG or higher are required, contact Inovance.

## 3.8 Connecting the Control Signal (CN1)

Observe the requirements in standard EN 60204-1 during connecting control circuit cables.

### 3.8.1 Wiring of I/O Signal Cables

#### I/O signal cable selection

It is recommended to use shielded signal cables to prevent I/O signal circuit from being disturbed by external noise. Use separate shielded cables for different analog signals. It is recommended to use shielded twisted pairs for digital signals.

Shielded twisted pairs

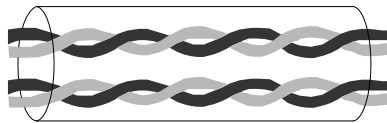

Figure 3-33 Diagram of shielded twisted pairs

## I/O signal layout

I/O signals include DI/DO signals and relay output signals.

Observe the following requirement during control circuit wiring:

Route the control circuit cables and main circuit cables or other power cables through different routes with a distance of at least 30 cm. Failure to comply may result in disturbed I/O signals.

### 3.8.2 Position Reference Input Signals

For descriptions of position reference input signals, see *"Table 3-7" on page 81*.

The reference pulses and signs on the host controller side can be outputted through the differential drive or open-collector. The following table lists the maximum input frequency and minimum pulse width.

Table 3-31 Relation between pulse input frequency and pulse width

Pulse Mode		Maximum Frequency (pps)	Minimum Pulse Width (us)
Low-speed	Differential	200 k	2.5
	Open-collector	200 k	2.5
High-speed differential		4 M	0.125

### Note

- You can either use high-speed pulses or low-speed pulses, but not both of them together.
- If the output pulse width of the host controller is smaller than the minimum pulse width, a pulse receiving error will occur on the drive.
- The symbol  $\surd$  represents shielded twisted pairs.

### Low-speed pulse reference input

- Differential mode



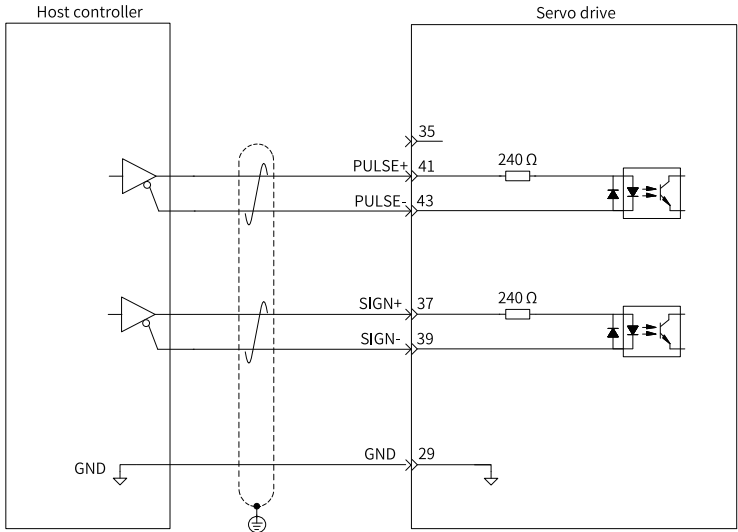

- Open-collector mode

- ① For use of the internal 24 V power supply of the servo drive:

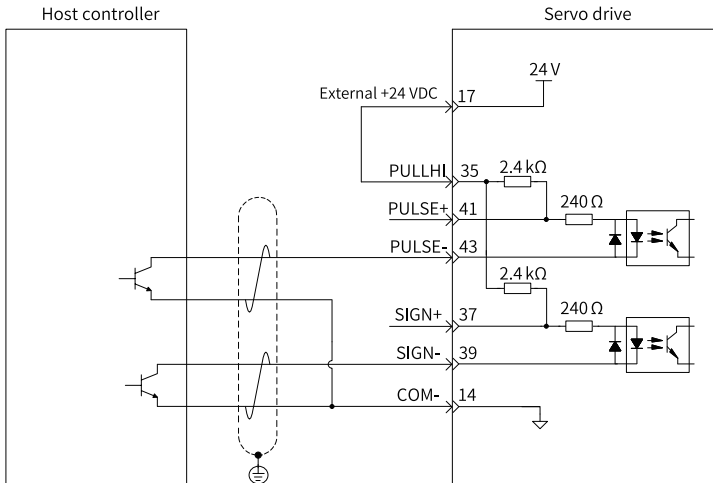

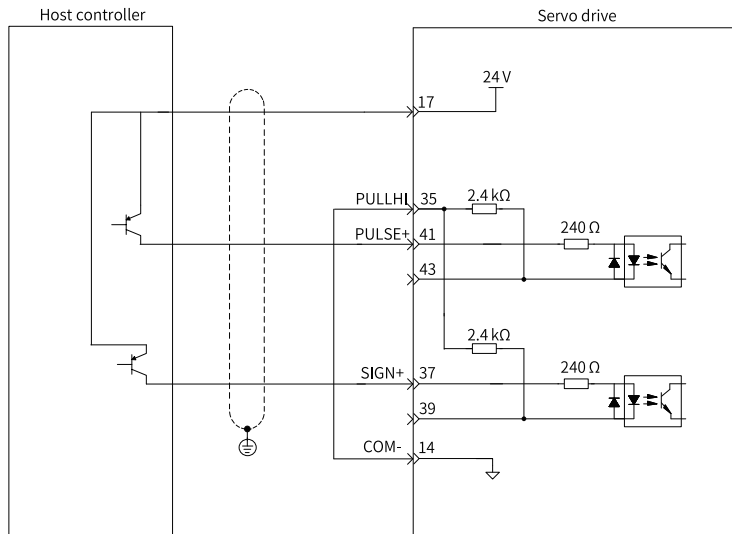

Wrong: Pin 14 (COM-) is not connected and a closed-loop circuit cannot be formed.

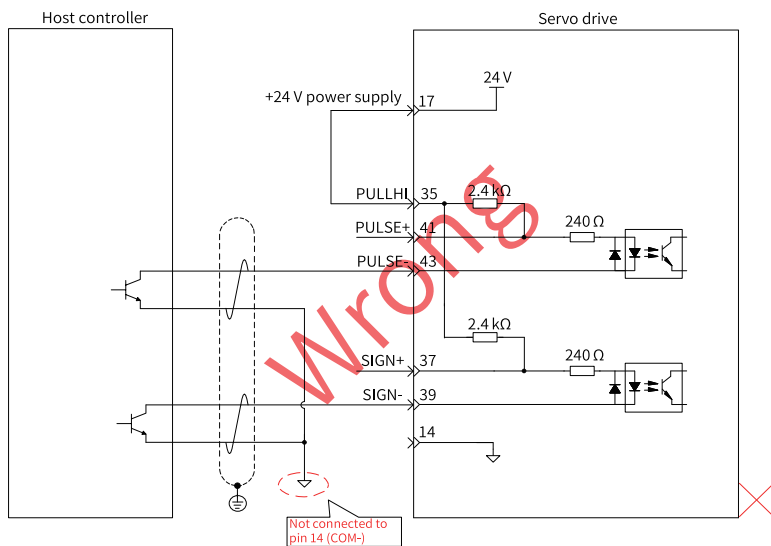

② For use of an external power supply:

- Scheme 1: Using the built-in resistor (recommended)

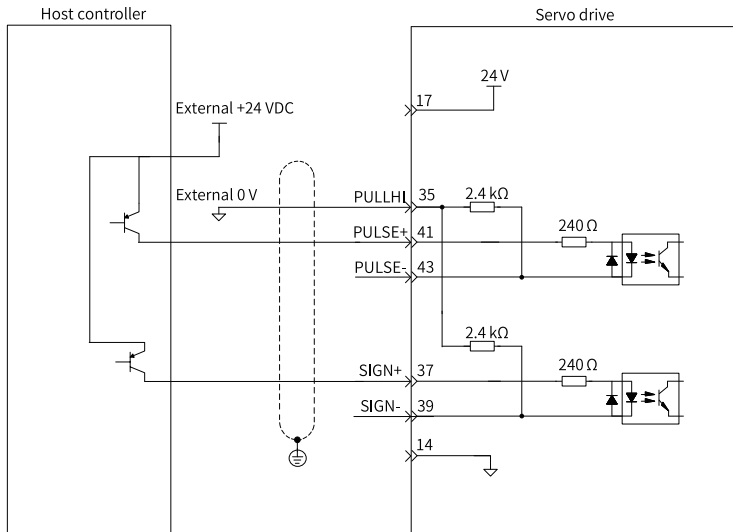
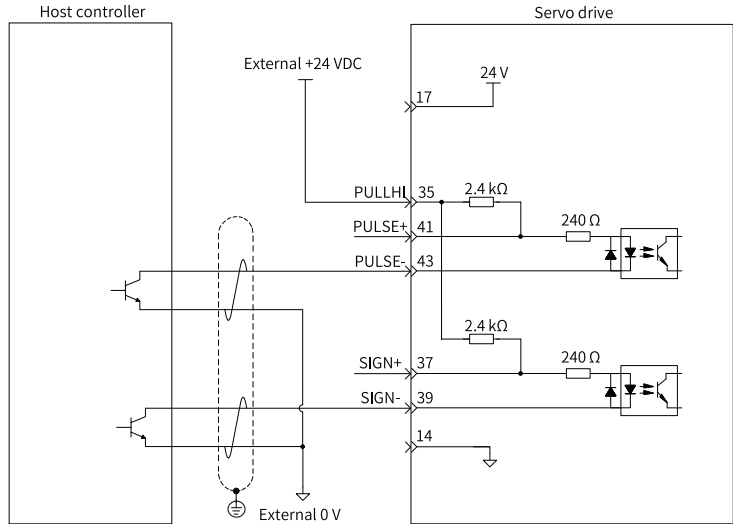

- Scheme 2: Using the external resistor

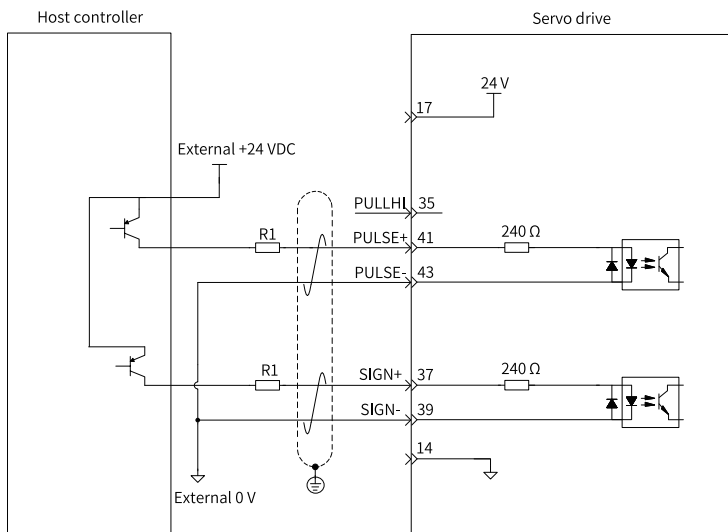
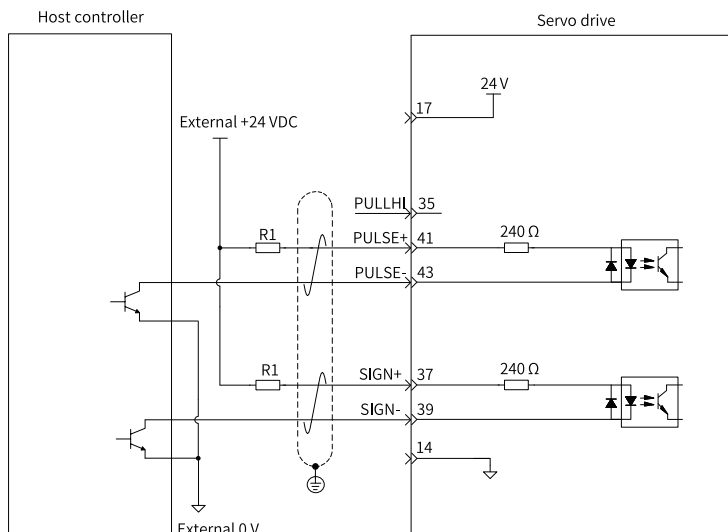

Select resistor R1 based on the following formula.

$$\frac{V_{CC} - 1.5}{R_1 + 240} = 10 \text{ mA}$$

Table 3-32 Recommended resistance of R1

V <sub>CC</sub> Voltage	Resistance of R1	Power of R1
24 V	2.4 kΩ	0.5 W
12 V	1.5 kΩ	0.5 W

- The following figures show examples of improper wiring.
- Improper wiring 1: The current limiting resistor is not connected, resulting in terminal burnout.

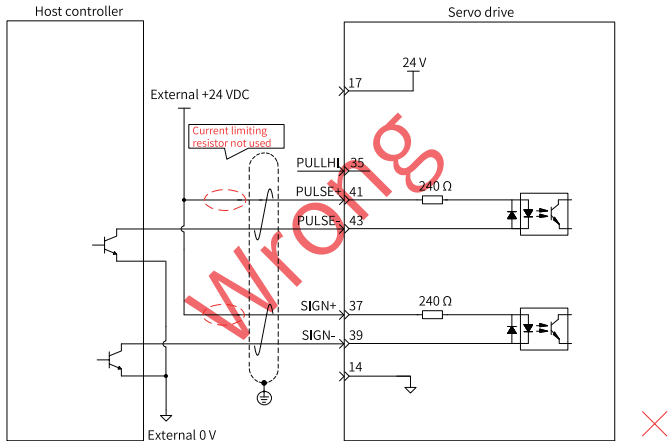

- Wrong wiring 2: Multiple terminals share the same current limiting resistor, resulting in pulse receiving error.

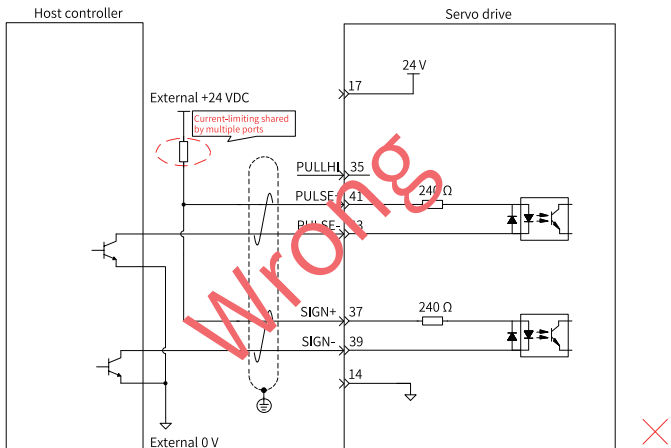

- Wrong wiring 3: The SIGN port is not connected, preventing these two ports from receiving pulses.

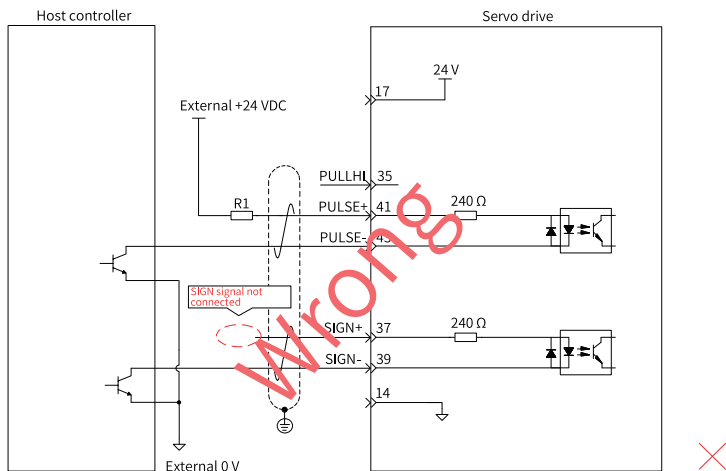
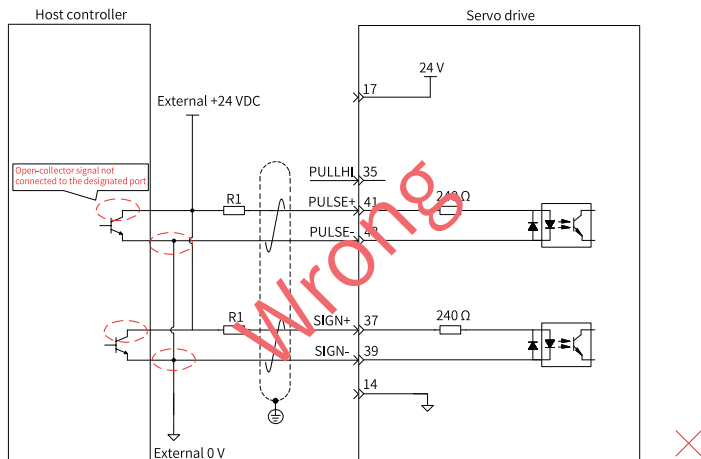
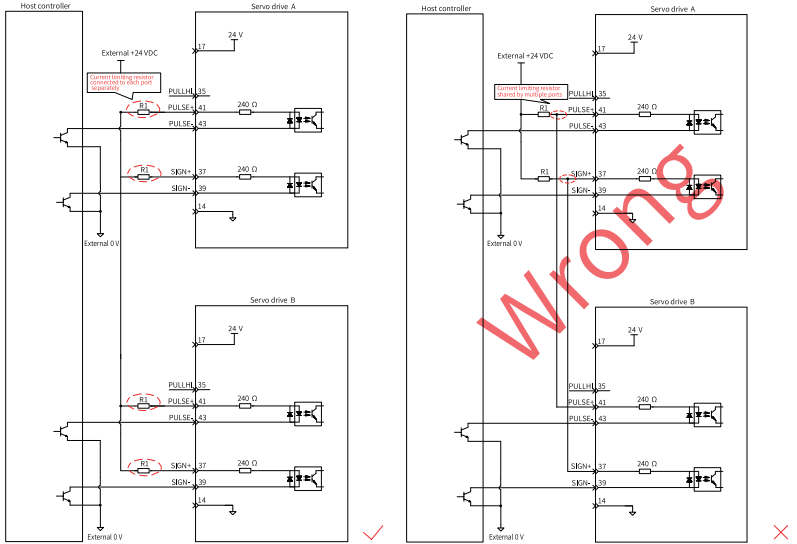

Figure 3-34

- Wrong wiring 4: Terminals are connected incorrectly, resulting in terminal burnout.



- Wrong wiring 5: Multiple terminals share the same current limiting resistor, resulting in pulse receiving error.



### High-speed pulse reference input

High-speed reference pulses and signs on the host controller side can be outputted to the servo drive through the differential drive only.

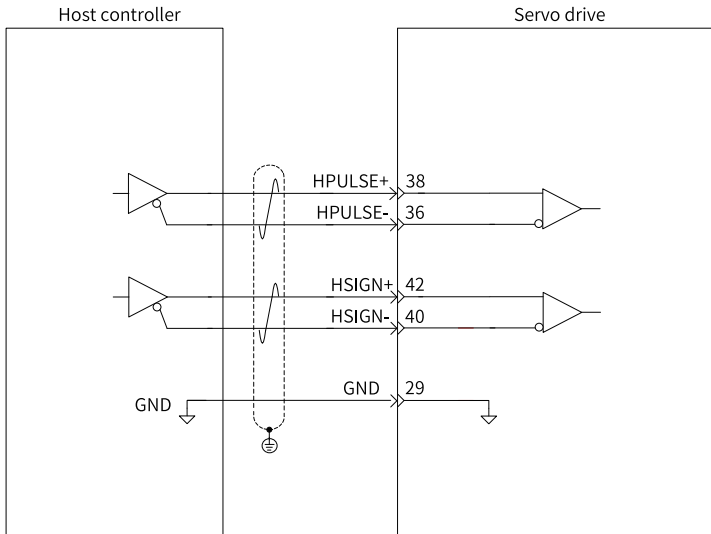



## Caution

The differential input must be 5 V. Otherwise, unstable pulse input will occur on the servo drive, resulting in the following situations:

- Pulse loss during pulse input
- Reference inverted during reference direction input

Connect 5V GND of the host controller to the GND of the servo drive to reduce noise interference.

### 3.8.3 DI/DO Signals

For description of DI/DO signals, see ["Table 3-8 " on page 81.](#)

#### DI circuit

The circuits for DI1 to DI9 are the same. The following description takes DI1 circuit as an example.

- The host controller provides relay output.
  - For use of an internal 24 V power supply of the servo drive

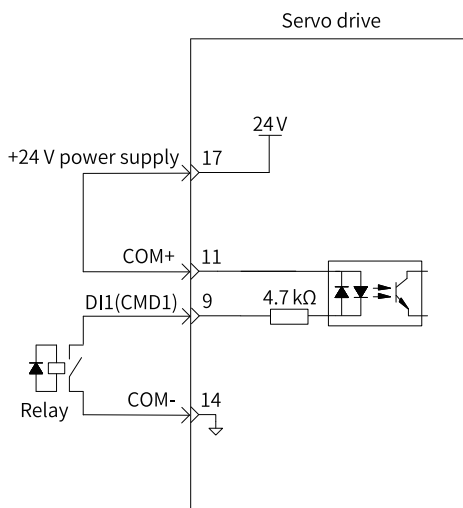

- For use of an external power supply



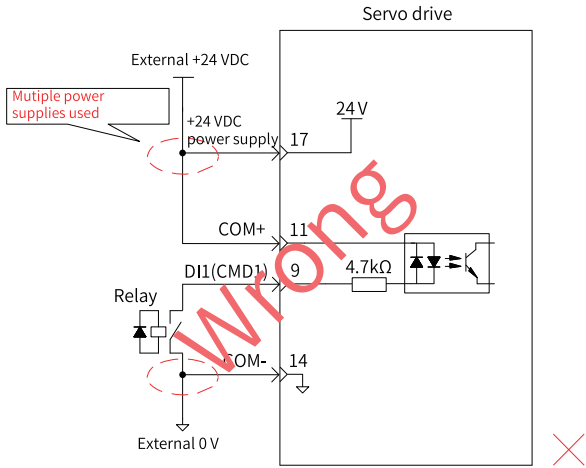
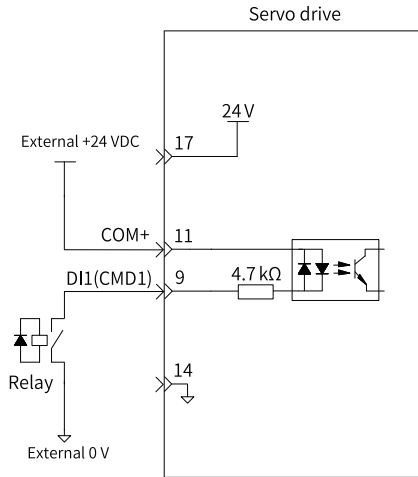

- The host controller provides open-collector output.
  - For use of an internal 24 V power supply of the servo drive

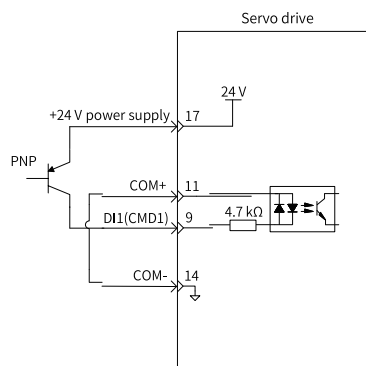
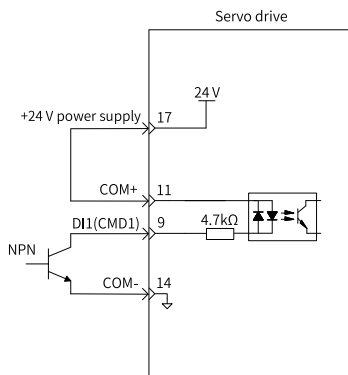

- For use of an external power supply

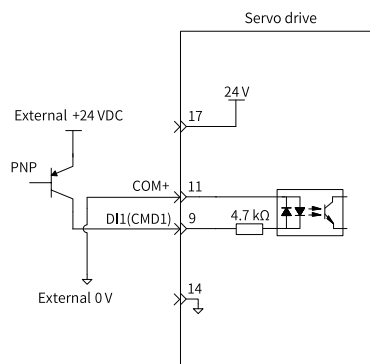
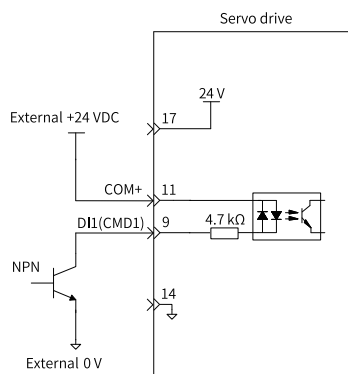

## Note

PNP and NPN input cannot be applied in the same circuit.

## DO circuit

The circuits for DO1 to DO5 are the same. The following description takes DO1 circuit as an example.

- The host controller provides relay input.

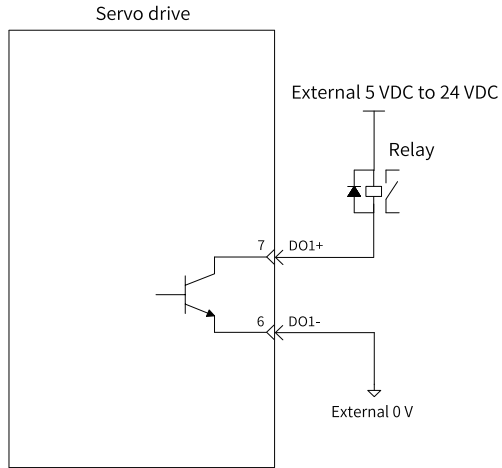

**Note**

When the host controller provides relay input, a flywheel diode must be installed. Otherwise, the DO terminals may be damaged.

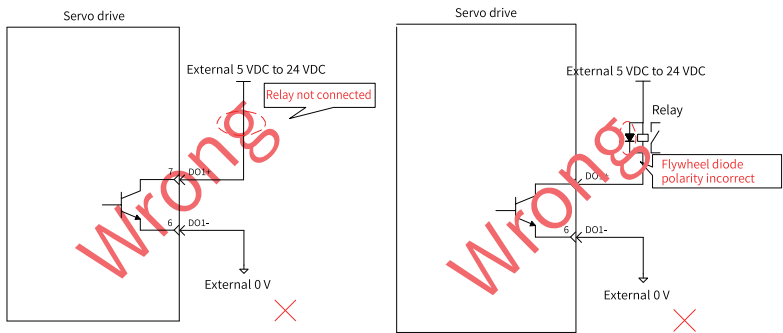

- The host controller provides optocoupler input.

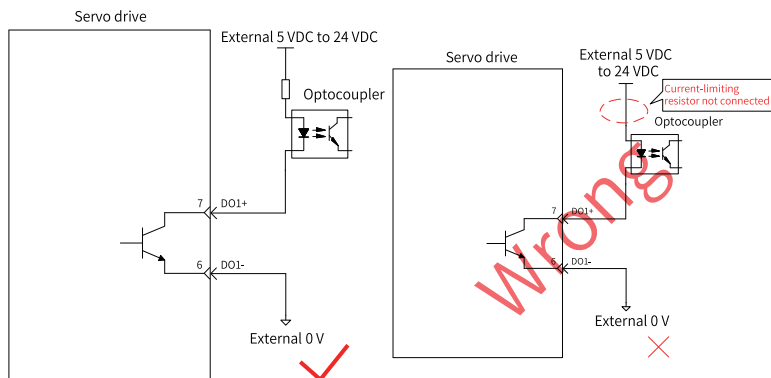

## Note

The maximum permissible voltage and current capacity of the optocoupler output circuit inside the servo drive are as follows:

- Maximum voltage: 30 VDC
- Maximum current: DC 50 mA

### 3.8.4 Encoder Frequency-Division Output Signals

For details on encoder frequency-division output signals, see ["Table 3-9" on page 82](#)

The encoder frequency-division output circuit outputs differential signals through the differential drive. Generally, this circuit serves to provide feedback signals to the host controller in a position control system. Use a differential or optocoupler receiving circuit on the host controller side to receive feedback signals. The maximum output current is 20 mA.

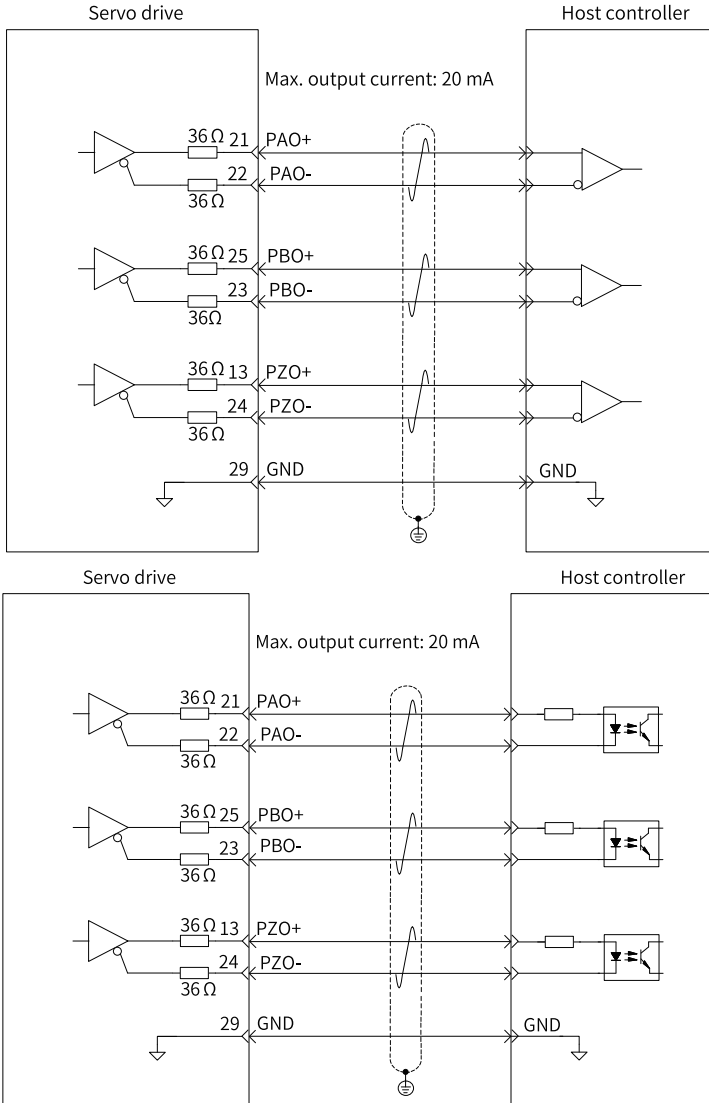

The encoder phase Z frequency-division output circuit supports open-collector signal output. Generally, this circuit serves to provide feedback signals to the host controller in a position control system. Use an optocoupler circuit, relay circuit, or bus receiver circuit on the host controller side to receive feedback signals.

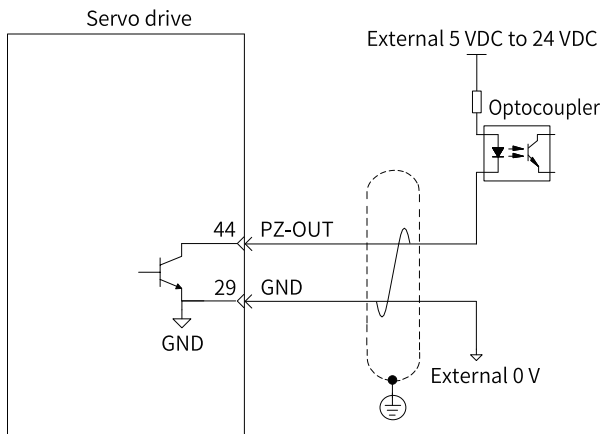

### ⚠ Caution

To reduce noise interference, use shielded twisted pairs to connect the 5V GND of the host controller to the GND of the servo drive.

The maximum permissible voltage and current capacity of the optocoupler output circuit inside the servo drive are as follows:

- Maximum voltage: 30 VDC
- Maximum current: DC 50 mA

### 3.8.5 Wiring of the Brake

The brake is used to prevent the motor shaft from moving and keep the motor and the motion part in locked positions when the servo drive is in the non-operating status.

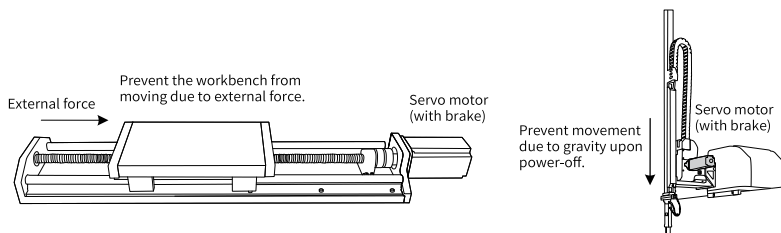

Figure 3-35 Application of the brake

 **Caution**

- Use the built-in brake for position-lock purpose only. Do not use this brake for any other purposes (such as braking) other than position-lock in the stop state.
- The brake coil has no polarity.
- Switch off the S-ON signal after the servo motor stops.
- When the servo motor with brake runs, the brake may generate a click sound, which does not affect its function.
- When brake coils are energized (the brake is released), magnetic flux leakage may occur on the shaft end. Pay special attention when using magnetic sensors around the servo motor.

The connection of the brake input signal is polarity-insensitive. Users need to prepare a 24 V power supply. The following figure shows the standard wiring of the brake signal (BK) and the brake power supply.

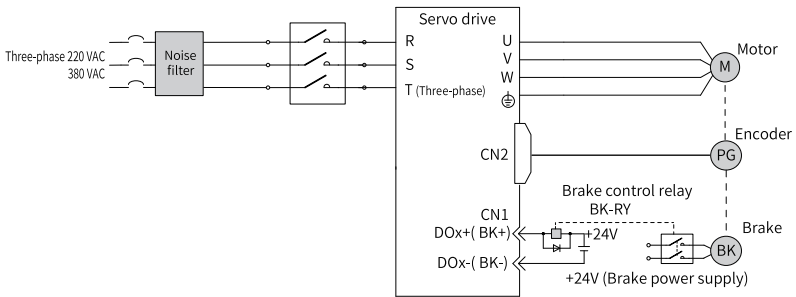

Figure 3-36 Wiring of the brake

**Pay attention to the following precautions during wiring:**

When deciding the length of the motor brake cable, take the voltage drop caused by cable resistance into consideration. The input voltage must be at least 21.6 V to enable the brake to work properly. The following table lists brake specifications of Inovance MS1 series servo motors.

Table 3–33 Brake specifications

Motor Model	Holding Torque (N·m)	Supply Voltage (VDC) ±10%	Coil Resistance ( $\Omega$ ) ±7%	Exciting Current (A)	Release Time (ms)	Apply Time (ms)	Backlash (°)
MS1H1-05B/10B	0.32	24	94.4	0.25	≤ 20	≤ 40	≤ 1.5
MS1H1-20B/40B MS1H4-40B	1.5		75.79	0.32	≤ 20	≤ 60	≤ 1.5
MS1H1-75B/ MS1H4-75B	3.2		57.6	0.42	≤ 40	≤ 60	≤ 1
MS1H2-10C/15C/ 20C/25C	8		25	0.96	≤ 30	≤ 85	≤ 0.5
MS1H2-30C/40C/ 50C	16		21.3	1.13	≤ 60	≤ 100	≤ 0.5
MS1H3-85B/13C/ 18C	12		29.7	0.81	≤ 60	≤ 120	≤ 0.5
MS1H3-29C/44C/ 55C/75C	50		14.4	1.67	≤ 100	≤ 200	≤ 0.5

---

## Note

- The brake cannot share the same power supply with other electrical devices. This is to prevent malfunction of the brake due to voltage or current drop caused by other working devices.
  - It is recommended to use cables with a cross-sectional area of 0.5 mm<sup>2</sup> and above.
-



### 3.9 Connecting the Communication Signals (CN3/CN4)

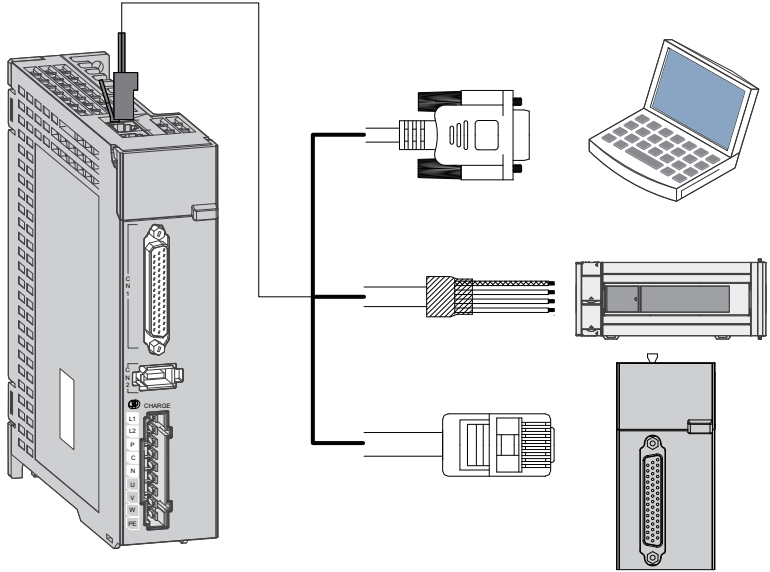

Figure 3-37 Wiring of communication signals

CN3 and CN4 are identical communication signal terminals connected in parallel internally.

CN3 and CN4 on the servo drive are used for communication between the servo drive and the PC, PLC, and other servo drives. For pin assignment of CN3/CN4, see ["3.4.4 Description of Communication Terminals \(CN3/CN4\)" on page 82](#).

#### 3.9.1 CAN Communication Connection

##### CAN communication with PLC

The following figure shows the cable connecting the servo drive and PLC during CAN communication.

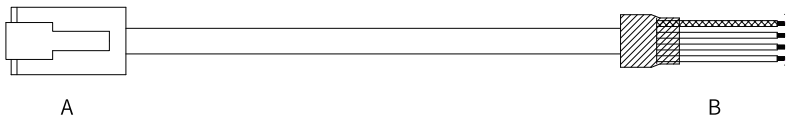

Figure 3-38 Outline drawing of cable used for CAN communication between the servo drive and PLC

Use a three-conductor shielded cable to connect the CAN bus, with the three conductors connected to CANH, CANL, and CGND (CGND represents isolated RS485

circuit) respectively. Connect CANH and CANL with two conductors twisted together. Connect CGND to the CAN reference ground. Connect the shield to the device ground. Connect a 120  $\Omega$  termination resistor on each end of the bus to prevent CAN signal reflection.

Table 3–34 Pin connection relation of the cable used for CAN communication between the servo drive and PLC

RJ45 on the Servo Drive Side (A)			PLC Side (B)		
Communication Type	Signal Name	Pin No.	Communication Type	Signal Name	Pin No.
CAN	CANH	1	CAN	CANH	1
	CANL	2		CANL	2
	CGND	3		CGND	3
-	PE (shield)	Enclosure	-	PE (shield)	Enclosure

### Multi-drive CAN communication

The following figure shows the cable used for parallel connection of multiple servo drives during CAN communication.

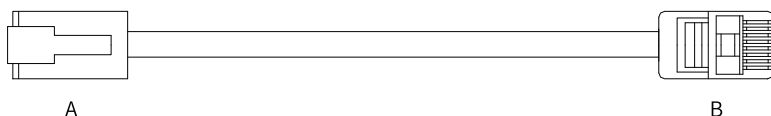

Figure 3-39 Outline drawing of multi-drive communication cable

Table 3–35 Pin connection relation of multi-drive communication cable (pins in CAN group used only)

RJ45 on the Servo Drive Side (A)			RJ45 on the Servo Drive Side (B)		
Communication Type	Signal Name	Pin No.	Communication Type	Signal Name	Pin No.
CAN	CANH	1	CAN	CANH	1
	CANL	2		CANL	2
	CGND	3		CGND	3
-	PE (shield)	Enclosure	-	PE (shield)	Enclosure

The following figure shows the CAN bus connection in daisy chain mode. It is recommended to use shielded twisted pairs for CAN bus connection. Connect CANH and CANL with twisted pairs. Connect a 120  $\Omega$  termination resistor on each end of the bus to prevent signal reflection. Connect the reference grounds of CAN signals of all the nodes together. A maximum of 64 nodes can be connected.

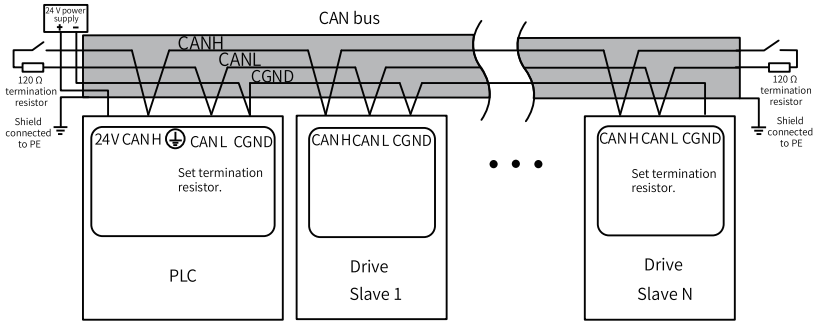

Figure 3-40 CAN bus topology



**Caution**

Do not connect the CGND terminal of the host controller to the GND terminal of the servo drive. Failure to comply will damage the machine.

The transmission distance of the CAN bus is directly related to the baud rate and communication cables. The following table describes the relationship between the maximum bus length and the baud rate.

No.	Transmission Distance	Baud Rate	Number of Nodes	Cross-sectional Area
1	25 m	1 Mbps	64	0.205 mm <sup>2</sup>
2	95 m	500 kbps	64	0.34 mm <sup>2</sup>
3	560 m	100 kbps	64	0.5 mm <sup>2</sup>
4	1100 m	50 kbps	64	0.75 mm <sup>2</sup>

### 3.9.2 Wiring of RS485 Communication

#### RS485 communication with PLC

The following figure shows the cable used for RS485 communication between the servo drive and PLC.

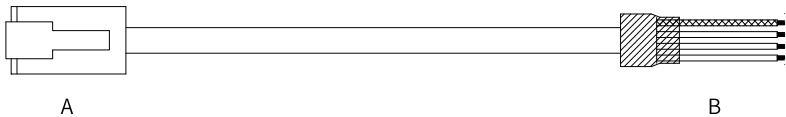

Figure 3-41 Outline drawing of the cable used for RS485 communication between the servo drive and PLC

Use a three-conductor shielded cable to connect the RS485 bus, with the three conductors connected to 485+, 485-, and GND (GND represents non-isolated RS485 circuit) respectively. Connect 485+ and 485- with two conductors twisted together and connect the remaining conductor to RS485 reference ground. Connect the shield to the device ground PE. Connect a 120  $\Omega$  termination resistor on each end of the bus to prevent RS485 signal reflection.

Table 3-36 Pin connection relation of the cable used for RS485 communication between the servo drive and PLC

RJ45 on the Servo Drive Side (A)			PLC Side (B)		
Communication Type	Signal Name	Pin No.	Communication Type	Signal Name	Pin No.
RS485	485+	4	RS485	485+	4
	485-	5		485-	5
	GND	8		GND	8
-	PE (shield)	Enclosure	-	PE (shield)	Enclosure

### Wiring of multi-drive RS485 communication

The following figure shows the cable used for multi-drive RS485 communication.

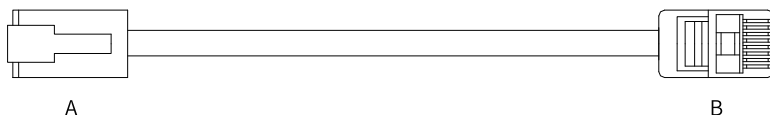

Figure 3-42 Outline drawing of the cable used for multi-drive RS485 communication

Table 3-37 Pin connection relation of the cable used for multi-drive RS485 communication (pins in 485 group used only)

RJ45 on the Servo Drive Side (A)			RJ45 on the Servo Drive Side (B)		
Communication Type	Signal Name	Pin No.	Communication Type	Signal Name	Pin No.
RS485	485+	4	RS485	485+	4
	485-	5		485-	5
	GND	8		GND	8
-	PE (shield)	Enclosure	-	PE (shield)	Enclosure

In case of a large number of nodes, connect the RS485 bus with the daisy chain mode. Connect the reference grounds of RS485 signals of all the nodes (up to 128 nodes) together.

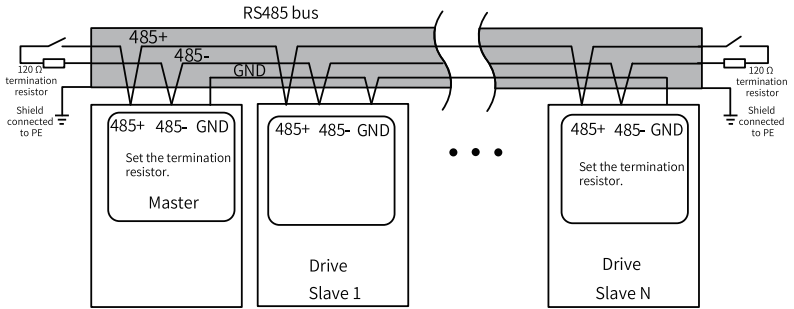

Figure 3-43 RS485 bus topology



**Caution**

Do not connect the GND terminal ( $\ominus$ ) of the host controller to the CGND terminal of the servo drive. Failure to comply will damage the machine.

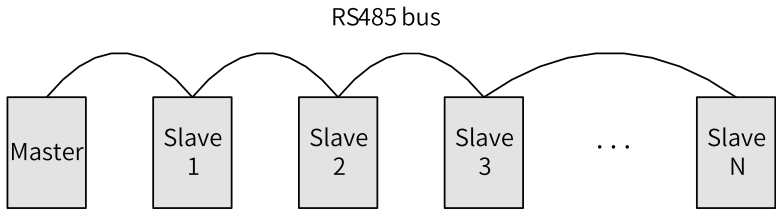

Figure 3-44 Daisy chain mode

The following table lists the maximum number of nodes and transmission distances supported by the standard RS485 circuit at different baud rates.

Table 3-38 Transmission distance and number of nodes

No.	Baud Rate	Transmission Distance	Number of Nodes	Cable Specifications
1	115.2 kbps	100 m	128	AWG26
2	19.2 kbps	1000 m	128	AWG26

### 3.9.3 Wiring of RS232 Communication with PC

You can connect the servo drive and the PC using the PC communication cable during RS232 communication. It is recommended to use RS232 communication interface. The outline drawing of the PC communication cable is shown in the following figure.



Figure 3-45 Outline drawing of the PC communication cable

Table 3-39 Pin connection relation between the servo drive and PC communication cable

RJ45 on the Servo Drive Side (A)		DB9 on the PC Side (B)	
Signal Name	Pin No.	Signal Name	Pin No.
RS232-TXD	6	PC-RXD	2
RS232-RXD	7	PC-TXD	3
GND	8	GND	5
PE (shield)	Enclosure	PE (shield)	Enclosure

Pin assignment of DB9 terminal on the PC side is shown in the following table.

Table 3-40 Pin assignment of DB9 terminal on the PC side ("B" in the preceding figure)

Pin No.	Assignment	Description	Terminal Pin Layout
2	PC-RXD	PC receiving end	
3	PC-TXD	PC transmitting end	
5	GND	Ground	
Enclosure	PE	Shield	

If the host controller supports USB interface only, use the serial-to-USB cable.

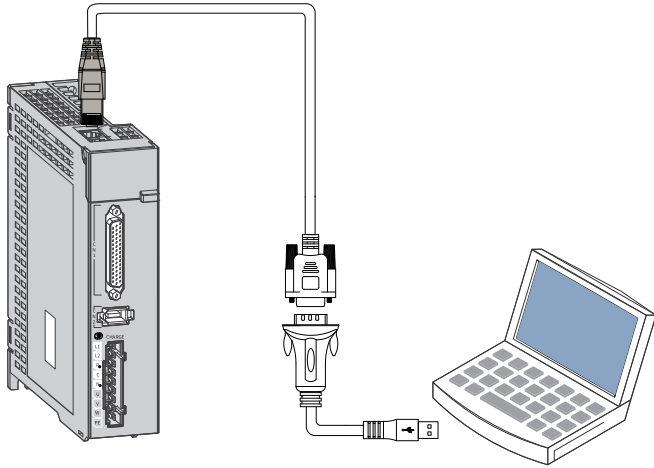

Figure 3-46 Outline drawing of the PC communication cable

Recommendations: Manufacture: Z-TEK Model: ZE551A, equipped with a 0.8 m USB extension cable Chip model: FT232

### 3.10 Wiring and Setting of the Regenerative Resistor

#### Connecting the regenerative resistor

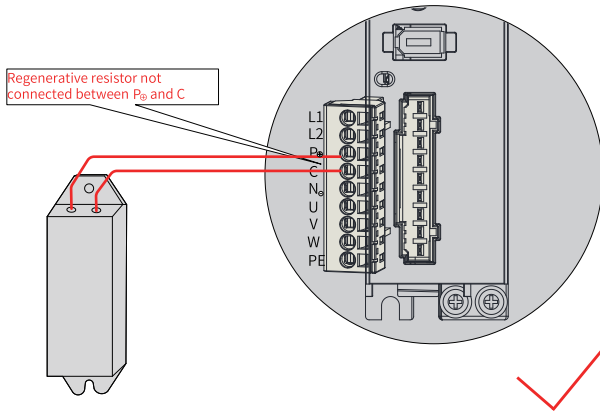

Figure 3-47 Wiring of external regenerative resistor

For cables used for terminals P<sup>+</sup> and C, see ["3.5.3 Recommended Cable Specifications and Models" on page 85.](#)



Observe the following precautions when connecting the external regenerative resistor:

- Remove the jumper between terminals P $\oplus$  and D before using the external regenerative resistor. Failure to comply will result in overcurrent and damage the braking transistor.
  - Do not connect the external regenerative resistor to the positive or negative pole of the bus directly. Failure to comply will damage the servo drive and result in a fire.
  - Select a resistor with resistance higher than or equal to the minimum permissible value. Failure to comply will result in Er.201 (Overcurrent) or damage the servo drive.
  - Make sure parameters H02-25 (Regenerative resistor setting), H02-26 (Power of external regenerative resistor) and H02-27 (Resistance of external regenerative resistor) are set properly before operating the servo drive.
  - Install the external regenerative resistor on an incombustible object such as a metal.
-



### Selecting the regenerative resistor

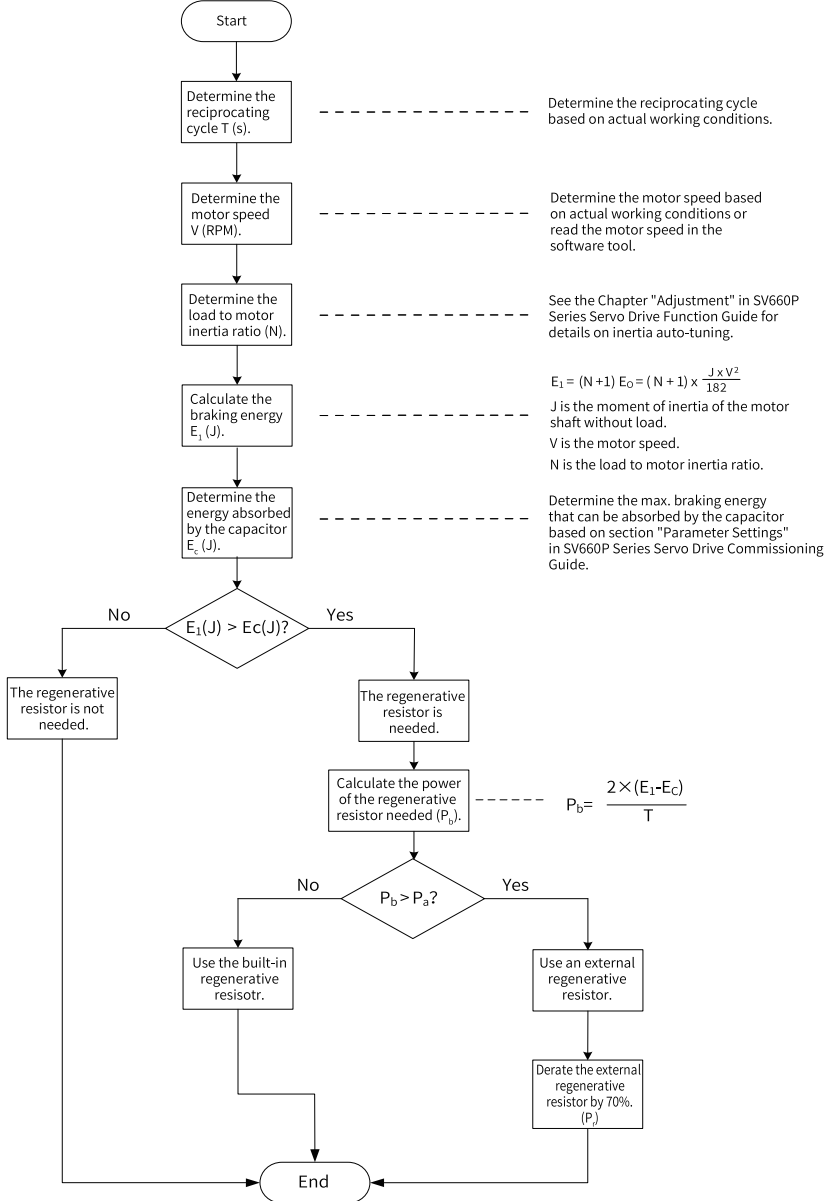

Figure 3-48 Flowchart for selecting the regenerative resistor

## Note

- Take the process in which motor decelerates from 3000 RPM to 0 RPM as an example, suppose the load inertia is N times the motor inertia, then the braking energy is  $(N+1) \times E_O$  when the motor decelerates from 3000 RPM to 0 RPM, and the energy consumed by the regenerative resistor is  $(N+1) \times E_O - E_C$  ( $E_C$  represents the energy absorbed by the capacitor). Suppose the reciprocating cycle is T, then the power of the regenerative resistor needed is  $2 \times [(N+1) \times E_O - E_C] / T$ . For values of  $E_O$  and  $E_C$ , see section "Parameter Settings" in SV660P Series Servo Drive Commissioning Guide.
- Determine whether to use the regenerative resistor according to the preceding figure and select a built-in or an external one as needed. Then, set H02-25 accordingly.
- The resistor with aluminum casing is recommended.

### ☆Related parameters

Para. No.	Name	Value Range	Description	Setting Condition	Effective Time	Default
H02-25	Regenerative resistor type	0: Built-in 1: External, natural cooling 2: External, forced air cooling 3: No resistor needed, braking energy absorbed by the capacitor only	Defines the regenerative resistor type and the mode of absorbing and releasing the braking energy.	At stop	Immediately	0

Take the H1 series 750 W model as an example. Suppose the reciprocating cycle (T) is 2s, the maximum speed is 3000 RPM, and the load inertia is 4 times the motor inertia, the required power of the regenerative resistor is as follows:

$$P_b = \frac{2 \times [(N+1) \times E_O - E_C]}{T} = \frac{2 \times [(4+1) \times 6.4 - 26]}{2} = 6 \text{ W}$$

The calculated result is smaller than the processing capacity ( $P_a = 25 \text{ W}$ ) of the built-in regenerative resistor, so a built-in regenerative resistor is sufficient.

If the inertia ratio in the preceding example is changed to 10 times the motor inertia, and other conditions remain the same, the required regenerative resistor power will be as follows:

$$P_b = \frac{2 \times [(N+1) \times E_O - E_C]}{T} = \frac{2 \times [(10+1) \times 6.4 - 26]}{2} = 44.4 \text{ W}$$

The calculated value is larger than the capacity ( $P_a = 25 \text{ W}$ ) of the built-in regenerative resistor, so an external regenerative resistor is required. The recommended power of the external regenerative resistor is  $P_b / (1-70\%) = 148 \text{ W}$ .

## Setting the regenerative resistor

- Using an external regenerative resistor

When  $P_b > P_a$ , an external regenerative resistor is needed. Set H02-25 to 1 or 2 based on the cooling mode of the regenerative resistor.

Use the external regenerative resistor with 70% derated, that is,  $P_r = P_b / (1 - 70\%)$ , and ensure the resistance of the regenerative resistor is higher than the minimum permissible resistance of the servo drive. Remove the jumper bar between terminals P⊕ and D, and connect the external regenerative resistor between terminals P⊕ and C.

For the wiring diagram and lead wire specifications of the external regenerative resistor, see "[Connecting the regenerative resistor](#)" on page 134. Set H02-25 to 1 or 2 based on the cooling mode of the regenerative resistor, and set the following parameters properly.

☆Related parameter

Para. No.	Name	Value Range	Unit	Description	Setting Condition	Effective Time	Default
H02-21	Minimum permissible resistance of regenerative resistor	Model dependent	-	Defines the minimum permissible resistance of the external regenerative resistor.	At display	-	Model dependent
H02-26	Power of external regenerative resistor	1~65535	W	Defines the power of the external regenerative resistor used. <b>Note:</b> The power of the external regenerative resistor cannot be lower than the calculated result.	At stop	Immediately	Model dependent
H02-27	Resistance of external regenerative resistor	1~1000	Ω	Defines the resistance of the external regenerative resistor used. <b>Note:</b> The resistance of the external regenerative resistor (H02-27) cannot be lower than the permissible minimum resistance defined by H02-21. Otherwise, Er.922 (Resistance of the regenerative resistor too small) will occur.	At stop	Immediately	Model dependent



- Set the power and resistance of the external regenerative resistor in H02-26 and H02-27.
- Ensure the resistance of the external regenerative resistor is higher than or equal to the permissible minimum resistance.
- When the regenerative resistor is used at its rated power rather than the processing power (average value) in environments within the specified temperature range, the temperature of the resistor will rise to above 120°C under continuous braking. To ensure safety, lower down the resistor temperature with forced air cooling, or use a resistor equipped with a thermal switch. For the load characteristics of the regenerative resistor, consult with the manufacturer.

Set the heat dissipation coefficient based on the heat dissipation condition of the external regenerative resistor.

☆Related parameter

Para. No.	Name	Value Range	Unit	Description	Setting Condition	Effective Time	Default
H02-24	Resistor heat dissipation coefficient	10–100	%	When an external regenerative resistor is used, set H02-24 to a value not higher than 30% in case of natural cooling or not higher than 50% in case of forced air cooling.	At stop	Immediately	30

## Note

Higher resistor heat dissipation coefficient indicates higher braking efficiency.

- Using the built-in regenerative resistor  
When  $P_b < P_a$  and  $E_1 > E_c$ , use the built-in regenerative resistor. In this case, set H02-25 to 0.  
  
When using the built-in regenerative resistor, connect terminals P⊕ and D with a jumper bar.
- Regenerative resistor not needed  
When  $E_1 < E_c$ , the regenerative resistor is not needed because the braking energy can be absorbed by the bus capacitor. In this case, set H02-25 to 3.
- External load torque applied, motor in generating state

When the motor direction of rotation is the same with the shaft direction of rotation, the motor outputs energy to the outside. In some applications where the motor direction of rotation is opposite to the shaft direction of rotation, the motor is in the generating state and feeds the electric energy back to the servo drive.

When the load is in the generating state continuously, it is recommended to adopt the common DC bus mode.

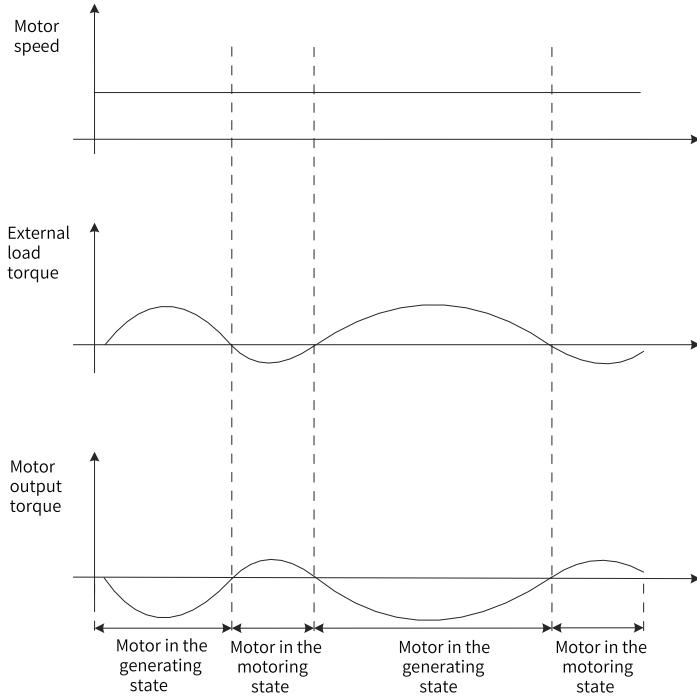

Figure 3-49 Example of the curve with external load torque

Take H1 series 750 W motors (rated torque: 2.39 N·m) as an example. When the external load torque is 60% of the rated torque and the motor speed reaches 1500 RPM, the power fed back to the servo drive is  $(60\% \times 2.39) \times (1500 \times 2\pi/60) = 225$  W. As the regenerative resistor needs to be derated by 70%, the power of the external regenerative resistor is:  $225/(1 - 70\%) = 750$  W, with resistance being 50  $\Omega$ .

## 4 Maintenance

### 4.1 Routine Maintenance

Standard operating conditions:

Average annual ambient temperature: 30°C Average load rate: < 80% Daily operating time: < 20 h

#### 4.1.1 Routine Checklist

Check the following items during routine inspection.

Table 4-1 Routine checklist

No.	Item	Checked
1	The ambient temperature and humidity are normal. There is no dust or unwanted objects in the servo drive.	<input type="checkbox"/>
2	There is no abnormal vibration or noise.	<input type="checkbox"/>
3	The voltage of the power supply is normal.	<input type="checkbox"/>
4	There is no strange smell.	<input type="checkbox"/>
5	There are no fibers adhered to the air inlet.	<input type="checkbox"/>
6	There is no intrusion of unwanted object on the load end.	<input type="checkbox"/>

#### 4.1.2 Routine Cleaning List

Check the following items during routine cleaning.

Table 4-2 Routine cleaning list

No.	Item	Checked
1	Clean the dust on the equipment surface, especially the metallic dust.	<input type="checkbox"/>
2	Keep the front end of the servo drive and the connectors clean.	<input type="checkbox"/>

### Note

- Cut off the power supply before cleaning. Clean the equipment with an air gun or a piece of dry cloth.
- Do not use the gasoline, diluent, alcohol, acidic or alkaline detergent during cleaning to prevent enclosure discoloration or damage.

## 4.2 Periodic Maintenance

### 4.2.1 Periodic Checklist

Table 4-3 Periodic checklist

No.	Item	Checked
1	The screws used to fix the couplings between devices are in place.	<input type="checkbox"/>
2	There is no sign of overheating.	<input type="checkbox"/>
3	Terminal blocks are in good condition without any sign of damage.	<input type="checkbox"/>
4	The clamping units of terminal blocks are in place.	<input type="checkbox"/>

### 4.2.2 Periodic Maintenance List

The electrical and electronic parts inside the servo drive may be mechanically worn out and degraded. To keep the servo drive and servo motor in good condition, perform parts replacement based on the replacement cycles listed in the following table. Contact Inovance or Inovance agent before replacement to double check whether the part needs to be replaced.

Equipment	Components	Standard Replacement Interval	Remarks
Servo drive	Bus filter capacitor	About five years	The standard replacement interval is for reference only. If any device/ component works improperly within the replacement interval, replace it immediately.
	Cooling fan	2 to 3 years (10000 h to 30000 h)	
	Aluminum electrolytic capacitor on the PCB	About five years	
	Pre-charge relay	100,000 operations (depending on the operating conditions)	
	Pre-charge resistor	20,000 operations (depending on the operating conditions)	
Motor	Bearing	3 to 5 years (20,000 h to 30,000 h)	
	Oil seal	5000 h	
	Encoder	3 to 5 years (20,000 h to 30,000 h)	
	Absolute encoder battery	Depends on the operating condition. See the operation instructions for the encoder battery for details.	

## 4.3 Parts Replacement

### 4.3.1 Disassembling the Motor Flat Key



#### Caution

- Observe all the requirements presented in this chapter. Failure to comply may result in equipment fault or damage.
- Violent disassembly is not allowed. Take enough care during disassembly to prevent personal injury.

Standard MS1 series motors in flange sizes 60, 80, and 130 adopt C-type flat key that carries the disassembly hole. To disassemble the flat key, select a proper disassembly bolt (inner hexagon bolt recommended) based on the following table.



Specifications and Dimensions		
Motor Flange Size	Dimensions of the Flat Key	Specifications of the Disassembly Bolt (Inner Hexagon Bolt)
Flange size 40	Type-A flat key—A3x3x14	No disassembly hole
Flange size 60	Type-C flat key—C5x5x16.5	M3x10 and above
Flange size 80	Type-C flat key—C6x6x25	M3x15 and above
Flange size 100	Type-C flat key—C8x7x35	M3x20 and above
Flange size 130	Type-C flat key—C8x7x35	M3x20 and above
Flange size 180	Type-C flat key—C10x8x64	M3x20 and above

- Tool needed: an Allen wrench
- Disassembly procedure:
  1. Select a proper disassembly bolt (inner hexagon bolt recommended) based on the motor model.
  2. Use an Allen wrench to screw down the bolt clockwise until A-A end of the flat key is completely detached from the keyway, as shown below.

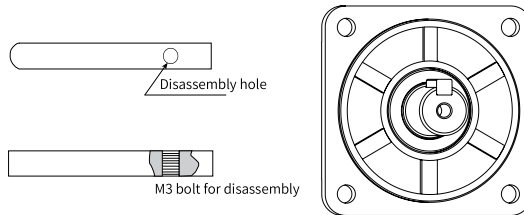

### 4.3.2 Disassembling the Motor Oil Seal

- Tools needed: a pair of needle-nose pliers, a pair of slip-proof gloves, and a piece of cotton cloth
- Procedure:
  1. Put the cotton cloth onto the supporting point B to avoid the end cover from being scratched during disassembly.
  2. Secure the motor and use the needle-nose pliers to hold point A of the oil seal lip.
  3. Pry the oil seal out gradually against the supporting point B.

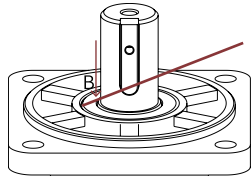

(Point B acts on the shaft extension stairs)

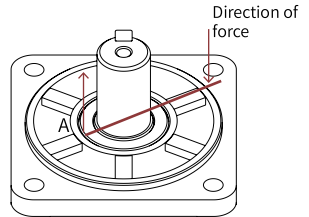

(Point A acts on the oil seal lip)

## 5 Appendix 1 Certifications and Standards Compliance

### 5.1 Compliance List

Table 5-1 Compliance list

Certifications	Directives		Standards
CE	EMC	2014/30/EU	EN IEC 61800-3
	LVD	2014/35/EU	EN 61800-5-1 EN 60034
	RoHS	2011/65/EU	EN 50581
UL/cUL certification	-		UL61800-5-1 C22.2 No.274-17 UL 1004-6 CSA C22.2 No. 100-14

### Note

The drive complies with the latest version of directives and standards for CE and UL/cUL certifications.

### 5.2 CE Certification



Figure 5-1 CE mark

- The CE mark indicates compliance with the Low Voltage Directive (LVD), Electromagnetic Compatibility (EMC), and Restriction of Hazardous Substances (RoHS) directives.
- The CE mark is required for engaging in commercial business (production, importation, and distribution) in Europe.
- The servo drive complies with LVD, EMC, and RoHS directives and carries the CE mark.
- Machines and devices integrated with this drive must also comply with CE requirements for distribution in Europe.
- The integrator who integrates this drive into other products and attaches CE mark to the final assembly has the responsibility of ensuring compliance with CE certification.

## 5.2.1 Requirement for Compliance with EMC Directive

The SV660P series servo drive, which is applicable to the first environment and second environment, complies with EMC Directive 2014/30/EU and standard EN IEC 61800-3.

As required by EMC Directive 2014/30/EU and standard EN IEC 61800-3, install an EMC filter on the input side of the drive and use shielded cables on the output side. Ensure the filter is grounded properly and the shield of the output cable is grounded 360 degrees.



- When applied in the first environment, the drive may generate radio interference. In addition to the CE compliance requirements described in this chapter, take additional measures to prevent radio interference if necessary.
  - The manufacturer of the system integrated with this drive is responsible for ensuring compliance with EMC directives and EN IEC 61800-3 based on the application environment of the system.
- 

## Introduction to EMC standards

Electromagnetic compatibility (EMC) describes the ability of electrical and electronic devices to work properly in the electromagnetic environment without introducing electromagnetic interferences that disturb the operation of other local devices or systems. In other words, EMC includes two aspects: 1) The electromagnetic interference generated by a device during normal operation cannot exceed a certain limit. 2) The device must have sufficient immunity to the electromagnetic interference in the environment.

EN IEC 61800-3 defines the following two types of environments.

- First environment: Environment that includes domestic premises, and establishments directly connected without intermediate transformers to a low-voltage power supply network which supplies buildings used for domestic purposes
- Second environment: Environment that includes all establishments other than those directly connected to a low-voltage power supply network which supplies buildings used for domestic purposes

Drives are divided into the following four categories based on the intended application environment.

- Category C1 drive: Power drive system (PDS) with rated voltage less than 1000 V, intended for use in the first environment

- Category C2 drive: PDS with rated voltage less than 1000 V, which is neither a plug-in device nor a movable device and, when used in the first environment, is intended to be installed and commissioned only by professionals
- Category C3 drive: PDS with rated voltage less than 1000 V, intended for use in the second environment and not intended for use in the first environment
- Category C4 drive: PDS with rated voltage equal to or above 1000 V, or rated current equal to or above 400 A, or intended for use in complex systems in the second environment

## 5.2.2 Requirements for Compliance with LVD

The drive has been tested in accordance with EN61800-5-1 to determine compliance with LVD. Observe the following requirements to enable machines and devices integrated with this drive to comply with LVD.

### Installation location

Install the drive in a place with overvoltage category III and pollution degree 1 or 2 as specified by IEC 60664-1.

### Installation environment

For requirements of the installation environment, see ["2.1.2 Installation Environment" on page 30](#).

### Requirements of IP rating

The drive must be installed in a fireproof cabinet with doors that provide effective electrical and mechanical protection. The installation must conform to local and regional laws and regulations and relevant IEC standards.

Drives (IP20) intended to be installed inside the cabinet must be installed in a structure that prevents intrusion of unwanted objects from the top and the front.

### Main circuit wiring requirements

For wiring requirements of main circuit terminals, see ["3.5.2 Main Circuit Wiring Requirements" on page 84](#).

### Protective device requirements

To comply with EN 61800-5-1, install a fuse/circuit breaker on the input side of the drive to prevent accidents caused by short circuit in the internal circuit.

For recommended fuse/circuit breaker models, see Chapter "Optional Parts" in "SV660P Series Servo Drive Selection Guide".

### 5.3 UL&cUL Certification



Figure 5-2 UL/cUL mark

The UL/cUL mark is commonly applied to products sold in United States and Canada. It indicates that UL has performed product tests and evaluation, and determined that their stringent standards have been met. For a product to receive UL/cUL certification, the main components inside the product must also be UL certified.

The drive has been tested in accordance with UL 61800–5–1 and CSA C22.2 No. 274-17 to determine compliance with UL/cUL standards. Observe the following requirements to enable machines and devices integrated with this drive to comply with UL/cUL standards.

#### Installation location

Install the drive in a place with overvoltage category III and pollution degree 1 or 2 as specified by UL61800–5–1.

#### Ambient temperature

Keep the ambient temperature within the following range based on the IP rating:  
Ambient temperature for open-type drives: 0°C to 50°C

#### Installation requirements

Installation requirements for open-type drives:

SV660P series servo drives are open-type drives that must be installed in a fireproof cabinet with the housing that provides effective electrical and mechanical protection. The installation must conform to local laws and regulations and related NEC requirements.

#### Main circuit wiring requirements



On-site installation of output terminals (such as P $\ominus$ , C, and N $\ominus$ ) is not allowed.

---

- Terminals P⊕, C, and NØ are used to connect optional parts. Do not connect these terminals to an AC power supply.
- To protect the main circuit, phase power separate and cover the surface that may come into contact with the main circuit.
- Do not allow unwanted objects from entering the wiring part of the terminal block.
- Do not solder the twisted conductors.
- The tightening torque may vary with terminals. Tighten terminal screws with the specified tightening torque. You can use a torque screwdriver, torque ratchet, or torque wrench to tighten terminal screws.
- When using an electric screwdriver to tighten terminal screws, set the electric screwdriver to low speed to prevent damage to the terminal screws.
- Tighten the terminal screws with an angle not higher than 5°. Failure to comply may damage the terminal screws.

### **Control circuit wiring requirements**

Observe the requirements in standard UL 508 during wiring.

### **Cable requirements**

Cable dimensions must be compliant with requirements in NEC (National Electric Code) and CEC (Canadian Electrical Code) Part I and local regulations.

- Use cables with copper conductors.
- It is recommended to use indoor PVC cables with a voltage class of 600 V and a maximum temperature of 75°C in continuous operation under the following conditions:
  - Ambient temperature: < 40°C
  - Working normally at rated values

If the recommended cable specifications for peripheral devices or optional parts exceed the applicable cable specification range, contact Inovance.

### **Cable selection**

To comply with UL61800-5-1 and CSA C22.2 No. 274-17, power cables used for SV660P series servo drives must meet the following requirements:

- Compliant with NEC and Table 310-16 of NFPA70
- Comprised of copper conductors with a rated temperature not lower than 75°C (167°F)
- 14 AWG or higher
- With a rated voltage not lower than the rated voltage of the servo drive

It is recommended to use cables compliant with UL758 Style 2517 and Style 2586 as motor main circuit cables.

## Protective device requirements

To comply with UL 61800-5-1, install a fuse/circuit breaker on the input side of the drive to prevent accidents caused by short circuit in the internal circuit.

Install sufficient protective devices against short circuit in branch circuits according to applicable regulations and this guide. The drive is applicable to circuits with a rated breaking capacity lower than 5000 A and a maximum voltage of 480 VAC (400 V class).

## Note

The following tables list recommendations for different types of fuses and circuit breakers.

Fuse type: Semiconductor Fuse						
Servo Drive Size	Servo Drive Model	Rated Input Current	Recommended Fuse (UL-compliant FWH Series Fuse)			
			Manufacturer	Model	Rated Voltage	Rated Current
Three-phase 380 V						
Size E	SV660P T017I	12 A	COOPER BUSSMANN LLC	FWH-50B	500 V	50 A
	SV660P T021I	16 A		FWH-70B	500 V	70 A
	SV660P T026I	21 A		FWH-125B	500 V	125 A

Circuit Breaker Type: Inverse Time Circuit Breaker						
Servo Drive Size	Servo Drive Model	Rated Input Current	Recommended Fuse (UL-compliant 3VA6 Series Fuse)			
			Manufacturer	Model	Rated Voltage	Rated Current
Single-phase 220 V						
Size A	SV660PS1 R6I	2.3 A	SIEMENS AG	3VA6140-6HL31	480 V	40 A
	SV660PS2 R8I	4.0 A		3VA6140-6HL31	480 V	40 A
Size B	SV660PS5 R5I	7.9 A		3VA6140-6HL31	480 V	40 A
Size C	SV660PS7 R6I	9.6 A		3VA6210-6HL31	480 V	100 A
Size D	SV660P S012I	12.8 A		3VA6210-6HL31	480 V	100 A
Three-phase 220 V						



Circuit Breaker Type: Inverse Time Circuit Breaker						
Servo Drive Size	Servo Drive Model	Rated Input Current	Recommended Fuse (UL-compliant 3VA6 Series Fuse)			
			Manufacturer	Model	Rated Voltage	Rated Current
Size C	SV660PS7 R6I	5.1 A	SIEMENS AG	3VA6210-6HL31	480 V	100 A
Size D	SV660P S012I	8.0 A		3VA6210-6HL31	480 V	100 A
Three-phase 380 V						
Size C	SV660PT3 R5I	2.4 A	SIEMENS AG	3VA6210-6HL31	480 V	100 A
	SV660PT5 R4I	3.6 A		3VA6210-6HL31	480 V	100 A
Size D	SV660PT8 R4I	5.6 A		3VA6210-6HL31	480 V	100 A
	SV660P T012I	8.0 A		3VA6210-6HL31	480 V	100 A

## 6 Appendix 2 Common EMC Problems and Solutions

### 6.1 Malfunction of the Residual Current Device (RCD)

If an RCD is needed, select the RCD according to the following requirements:

- The drive may generate DC leakage current in the protective conductor, a B-type RCD therefore must be used.
- The drive may generate high-frequency leakage current during operation. To prevent malfunction of the RCD, install an RCD with tripping current not lower than 100 mA for each servo drive.
- When multiple drives connected in parallel share one RCD, select an RCD with tripping current not lower than 300 mA.
- Recommended RCD manufacturers are Siemens and Schneider.

When malfunction occurs on the RCD, take the following measures.

Table 6-1 Measures against leakage current

Symptom	Possible Cause	Measure
The RCD trips at the moment of power-on.	The anti-interference performance of the RCD is weak.	<ul style="list-style-type: none"> <li>• It is recommended to use Siemens or Schneider RCDs.</li> <li>• It is recommended to use an RCD with a higher tripping current.</li> <li>• Move the unbalanced load to the front end of the RCD.</li> </ul>
	The tripping current of the RCD is too low.	
	An unbalanced load is connected to the rear end of the RCD.	
	The capacitance of the front end of the servo drive against the ground is too high.	
The RCD trips during operation.	The anti-interference performance of the RCD is weak.	<ul style="list-style-type: none"> <li>• It is recommended to use Siemens or Schneider RCDs.</li> <li>• It is recommended to use an RCD with a higher tripping current.</li> <li>• Install a simple filter on the input side of the servo drive and wind magnetic rings on the LN and RST cables near the RCD, as shown in <a href="#">"Figure 6-1 Magnetic ring on the input side" on page 154.</a></li> <li>• Reduce the carrier frequency without compromising the performance.</li> <li>• Reduce the length of motor cables.</li> </ul>
	The tripping current of the RCD is too low.	
	An unbalanced load is connected to the rear end of the RCD.	
	The distributed capacitance of the motor cable or motor against the ground is too high.	

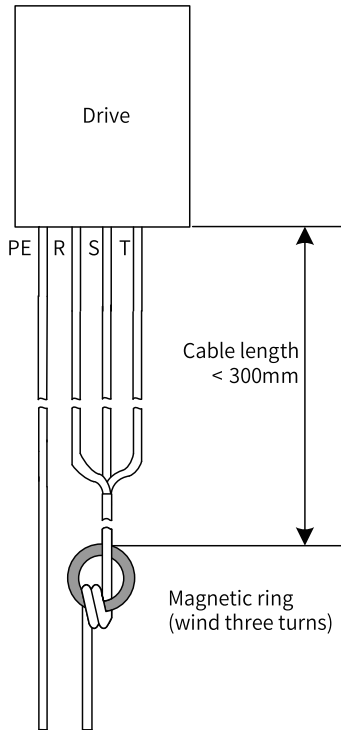

Figure 6-1 Magnetic ring on the input side

## 6.2 Harmonic Suppression

To suppress harmonics and improve the power factor to allow the drive to fulfill the standards, install an AC input reactor on the input side of the drive. For the reactor model and installation mode, see ["2.3.2 Instructions for Installing the AC Input Reactor" on page 53](#).

## 6.3 Control Circuit Interference

### 6.3.1 High-speed Pulse Interference

Take the measures listed in the following table to suppress interference.

No.	Measure
1	Used shielded twisted pair cables with both ends of the cable grounded (see <a href="#">"3.8.1 Wiring of I/O Signal Cables" on page 110</a> ).
2	Connect the motor enclosure to the PE terminal of the drive.

No.	Measure
3	Connect the PE terminal of the drive to the PE terminal of the mains power supply.
4	Add an equipotential bonding grounding cable between the host controller and drive (see " <a href="#">Figure 3-26</a> " on page 97).
5	Separate signal cables from power cables with a distance of at least 30 cm.
6	Install the ferrite clamp or wind the magnetic ring on the signal cable by one or two turns. (see " <a href="#">2.3.4 Instructions for Installing Magnetic Ring and Ferrite Clamp</a> " on page 54).
7	Install the magnetic ring on the output side (UVW) of the drive by two to four turns (see " <a href="#">2.3.4 Instructions for Installing Magnetic Ring and Ferrite Clamp</a> " on page 54).
8	Use shielded power cables and ground the shield properly.

### 6.3.2 I/O Signal Interference

The drive generates strong interference during operation. Although EMC measures are taken, interference may still exist due to improper wiring or grounding during use. When the drive disturbs or is disturbed by other devices, adopt the following measures.

No.	Measure
1	Use shielded I/O signal cables with the shield connected to the PE terminal. For details, see " <a href="#">3.8.1 Wiring of I/O Signal Cables</a> " on page 110.
2	Connect the PE terminal of the motor to the PE terminal of the drive, and connect the PE terminal of the drive to the PE terminal of the mains power supply.
3	Add an equipotential bonding grounding cable between the host controller and drive (see " <a href="#">Cabinet system grounding</a> " on page 96).
4	Install the magnetic ring on the output side (UVW) of the drive by two to four turns (see " <a href="#">2.3.4 Instructions for Installing Magnetic Ring and Ferrite Clamp</a> " on page 54).
5	Increase the capacitance of the capacitor for low-speed DIs. A capacitance up to 0.1 $\mu\text{F}$ is recommended, as shown in " <a href="#">Figure 6-2 I/O signal cables with capacitance increased</a> " on page 156.
6	Increase the capacitance of the capacitor between AI and GND. A capacitance up to 0.22 $\mu\text{F}$ is recommended.
7	Install a ferrite clamp or wind a magnetic ring on the signal cable by one or two turns. (see " <a href="#">2.3.4 Instructions for Installing Magnetic Ring and Ferrite Clamp</a> " on page 54).
8	Use shielded power cables and ground the shield properly.

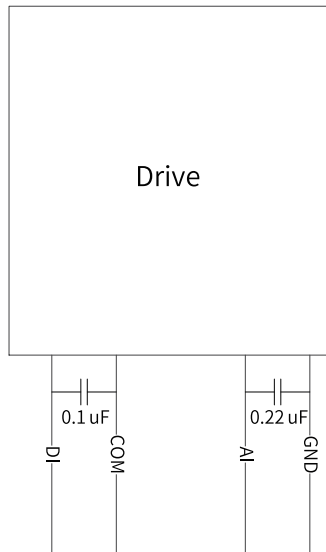

Figure 6-2 I/O signal cables with capacitance increased

## 6.4 RS485&CAN Communication Interference

Take the measures listed in the following table to suppress interference.

No.	Measure
1	Install a 120 $\Omega$ termination resistor on each end of the bus.
2	Replace with multi-conductor shielded twisted pair cables and ground both ends of the shield.
3	Separate communication cables from power cables with a distance of at least 30 cm.
4	Adopt daisy chain mode for multi-node communication layout.
5	Add an equipotential bonding grounding cable between nodes during multi-node communication (see " <a href="#">Cabinet system grounding</a> " on page 96).
6	Install ferrite clamps on both sides of the communication cable or wind the magnetic ring by one or two turns (see " <a href="#">Figure 2-21</a> " on page 55).
7	Install the magnetic ring on the output side (UVW) of the servo drive by two to four turns (see " <a href="#">Figure 2-20</a> " on page 54).
8	Use shielded power cables and ground the shield properly.

**Shenzhen Inovance Technology Co., Ltd.**

Add.: Building E, Hongwei Industry Park, Liuxian Road,  
Baocheng No. 70 Zone, Bao'an District, Shenzhen

Tel: +86-755-2979 9595

Fax: +86-755-2961 9897

<http://www.inovance.com>

**Suzhou Inovance Technology Co., Ltd.**

Add.: No. 16 Youxiang Road, Yuexi Town, Wuzhong  
District, Suzhou 215104, P.R. China

Tel: +86-755-2979 6666

Fax: +86-755-2961 6720

<http://www.inovance.com>



19011391A03