

☎ 400-012-6969

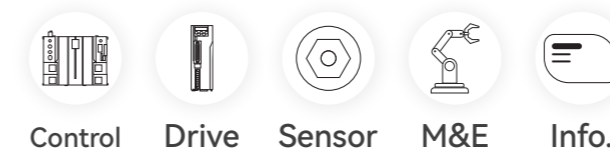

| X6 SERIES INTELLIGENT TYPE AC SERVO SYSTEM

| X5E SERIES ADVANCED TYPE AC SERVO SYSTEM

Zhejiang Hechuan Technology Co.LTD
WWW.HCFA.COM.CN

Headquarter address
No.9,Fucai Road, Longyou industrial Zone, Quzhou City, Zhejiang Province,
P.R.C
Hangzhou R&D Center
Floor 4, Block D, Quzhou Overseas Haichuang Park, No.1001, Wenyi West
Road, Yuhang District, Hangzhou City, Zhejiang Province, P.R.C

EtherCAT® is owned by Beckhoff Automation Co., Ltd.; MECHATROLINK® is owned by the MECHATROLINK
Association, which is an open field network;
The other products, product names, and product trademarks or registered trademarks described in this manual are
owned by each company.



All information in this document is
subject to change without notice.
Manual No.; October, 2021 Issue No. 8



To be the most valuable industrial automation
core components and solutions provider

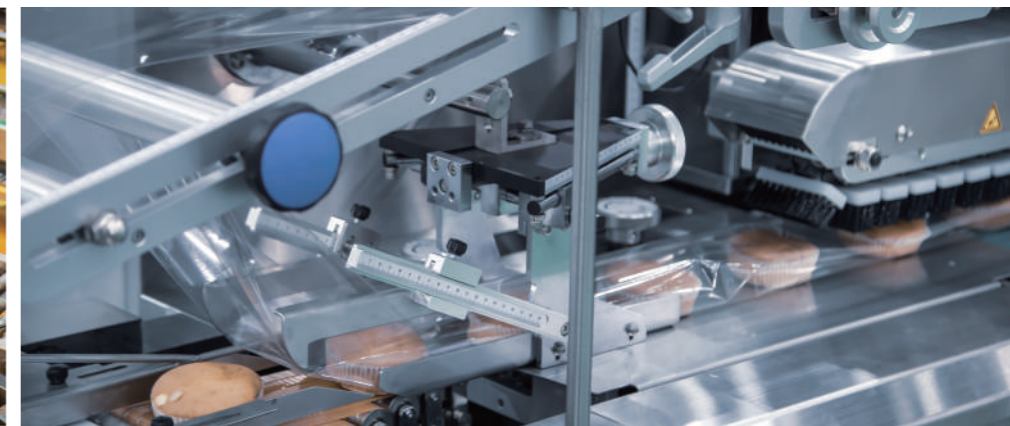
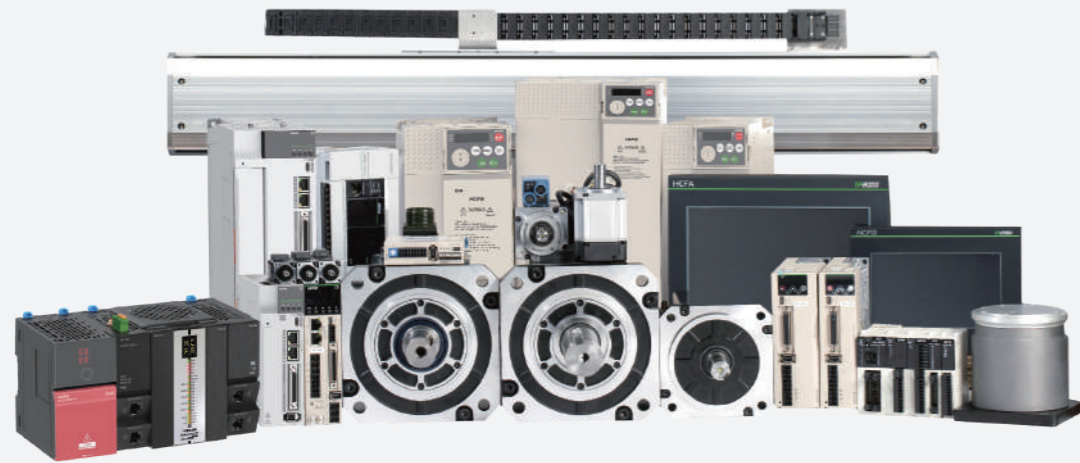

R&D Centers

4

Set up nationally

Sales Offices

40+

Sales elites gathering

Global Distributors

400+

Products sold worldwide

The products are widely used in OEM fields
such as photovoltaic, 3C, lithium batteries,
robots, packaging, textiles, logistics, lasers,
machine tool, etc.



X6

Series Intelligent Servo Drive

Naming Rule

SV-X6 E A - 075 - A - A 0 - 00 000

1 2 3 4 5 6 7 8

1 Functional classification	
E	Standard type
F	Full function type
L	Linear type

2 Product type	
A	Standard Common type
B	EtherCAT bus-type
N	CANopen bus-type
R	PROFINET type

3 Product power	
005	50W
010	100W
020	200W
040	400W
075	750W
100	1KW
150	1.5KW
200	2KW
250	2.5KW
300	3KW
500	5KW
750	7.5KW

4 Voltage specifications	
A	AC220V
T	AC380V

5 Control power	
A	AC power control

6 Product iteration serial no.	
2	N/A

7 Hardware type	
00	N/A

8 Software customized mark	
000	N/A



- | LCD display | High ease of use Position control
- | Compact Design | Automatic rigidity adjustment
- | Rich bus-type | EtherCAT Technology Group

General Specifications

Item	Specifications												
SV-X6 Series	005	010	020	040	075	100	150	200	250	200	300	500	750
Drive Power (W)	50	100	200	400	750	1000	1500	2000	2500	2000	3000	5000	7500
Rated Current (Arms)	0.9	1.2	2	3	4.5	6	10	12.5	15.6	6	9	13.5	21
Continuous running current (Arms)	0.9	1.2	2	3	4.5	6	10	12.5	15.6	6	9	13.5	21
Max Output Current (Arms)	2.7	3.6	6	9	13.5	18	30	37.5	37.5	18	27	40.5	52.5
Mian Circuit Power	single-phase 220 50~60 Hz				3-phase 220 50~60Hz				3-phase 380 50~60Hz				
Control Power	Single-phase 220V						Single-phase 380V						
Applicable encoder	17bit/23bit												
Control mode	7 control modes: position control, speed control, torque control, position/speed control, position/torque control, speed/torque control, entire closed-loop control (support X6FA/X6FB)												

Environment Specifications

Item	Specifications	
Temperature	Ambient temperature for use	0~55°C
	Ambient temperature for storage	-20~65°C
Humidity	Ambient temperature for use	20~85%RH or less(Without condensation)
	Ambient temperature for storage	20~85%RH or less(Without condensation)
Atmosphere for use& storage	Indoors(Not subject to direct sunlight); free from corrosive gas, flammable gas, oil mist, or dust	
Altitude	1000m or less	
Vibration	5.8m/s ² (0.6G) or less, 10~60Hz(No continuous operation allowed at frequency of resonance)	
Insulation and dielectric strength	1 minute at 1500 VAC across the primary and FG	

Config. Specifications

Function	Pluses Standard	Pluses full-fuctions	EtherCAT standard	EtherCAT full-fuctions	CANOpen standard	CANOpen full-fuctions	Profinet standard	Profinet full-fuctions
Analog Input		2x		2x		2x		2x
Analog Output		2x		2x		2x		2x
Pluses Input	✓	✓						
Pulse divider output	✓	✓		✓		✓		✓
STO Function	✓	✓		✓		✓		✓
Secondary Encoder	USB/485	USB/485	USB	USB/485	USB/485	USB/485	USB	USB
Z-phase collector output		✓		✓		✓		✓
Serial communication		✓		✓		✓		✓

Technical Specifications

Item	Specifications		
Position control	Pulse input	Max input pulse frequency	Open-collector pulse input: Up to 200KHz, pulse width larger than 2.5us
		Input pulse form	General input: Up to 500KHz, pulse width larger than 1 us
		Electronic gear setting	High-speed input: Up to 4MHz, pulse width larger than 125ns
	Pulse output	Smoothing	Pulse+ direction, A-Phase + B-Phase, CW+CCW
		Output pulse	Electronic gear : A/B (Encoder resolution/10000000 < A/B <Encoder resolution/2.5)
		Division ratio	Smoothing filter, FIR filter
Internal position mode	Encoder position or pulse synchronization output		
Speed control	Control method	Arbitrary frequency division	
	Analog input voltage range	Differential output: A/B/ Z, Open collector output: Z-phase	
	Torque limit function	Segment 1-16 internal position planning	
Torque control	Control method	External analog command control/0~16 segments speed selection can be realized by DI terminal combination./Communication setting	
	Analog input voltage range	DC±10V(Maximum speed at 10V)	
	Speed limit	Internal parameter setting or analog input	
Common functions	Control signal	I/O	9IN/9OUT
	Analog signal	I/O	2IN (±10v)
	Speed monitoring	Provided	
	Vibration control	Provided	
	Adaptive notch filter	Provided	
	Auto-tuning	Provided	
	Encoder output division and multiplication	Provided	
	Dynamic brake	Can be connected externally	
	Regeneration function	A larger power braking resistor can be connected	
	Protective functions	Overvoltage, power supply error, overcurrent, overheat, overload, encoder error, over speed, position deviation too large, parameter error	
Communication	USB	For PC communication (「Servostudio」connection)	
	Type	RS485	B:EtherCAT N:CANOPEN



Circuit breakers

Used to protect the power supply circuit and cut off the power supply in case of overcurrent.

Noise filter

Used to prevent noise outside.

Electromagnetic contactor

Turn on/off the servo power. Please install surge absorber when using.

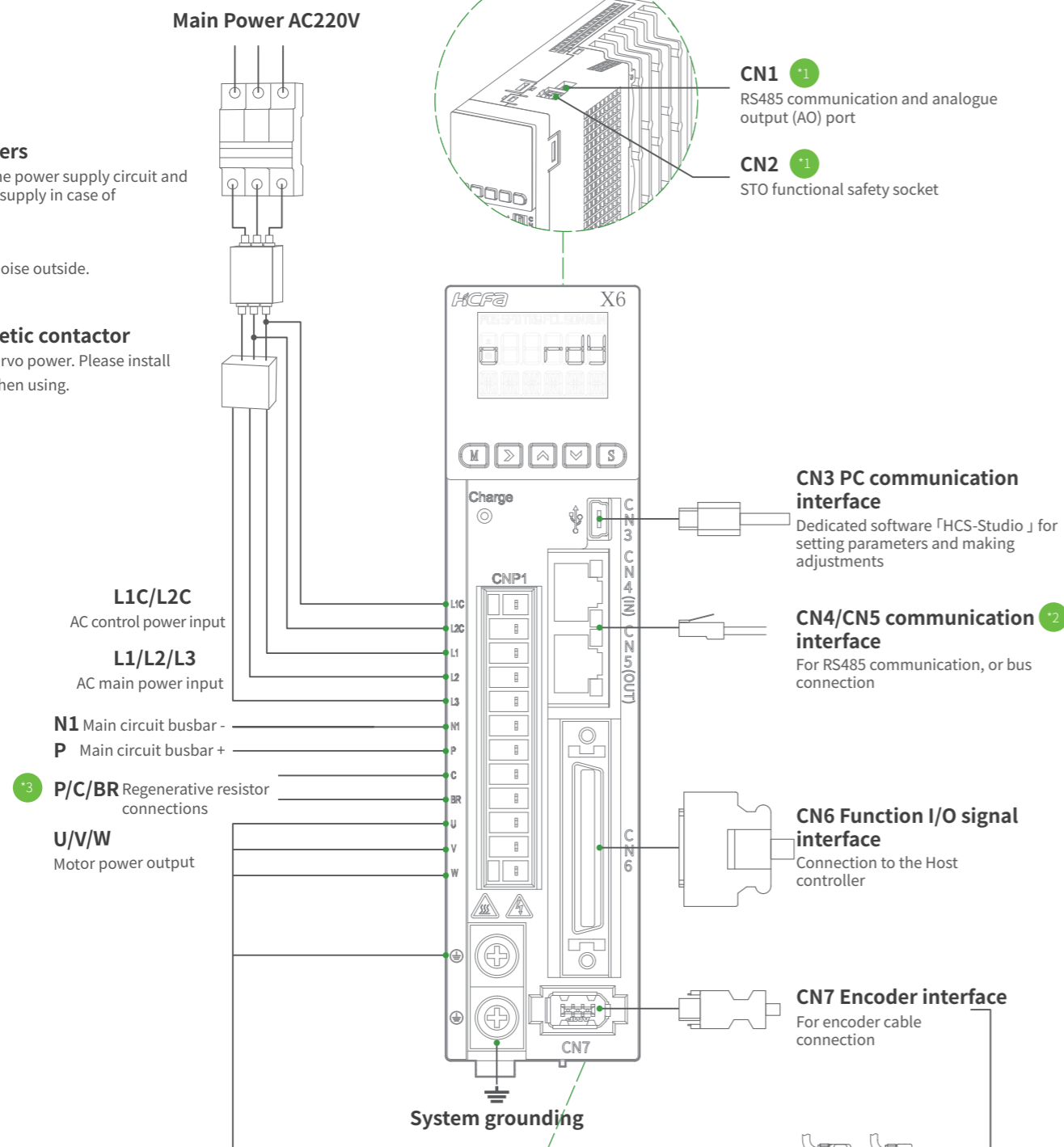

*1 Only for full-functional models

*2 Pulse type for RS485 communication
CANopen EtherCAT Pro finet models are used in bus communication interfaces

*3 P/C shorting required when using the driver's built-in regenerative resistor
When an external regenerative resistor is used, P/BR is inserted and the P/C stub is removed



Circuit breakers

Used to protect the power supply circuit and cut off the power supply in case of overcurrent.

Noise filter

Used to prevent noise outside

Electromagnetic contactor

Turn on/off the servo power. Please install surge absorber when using.

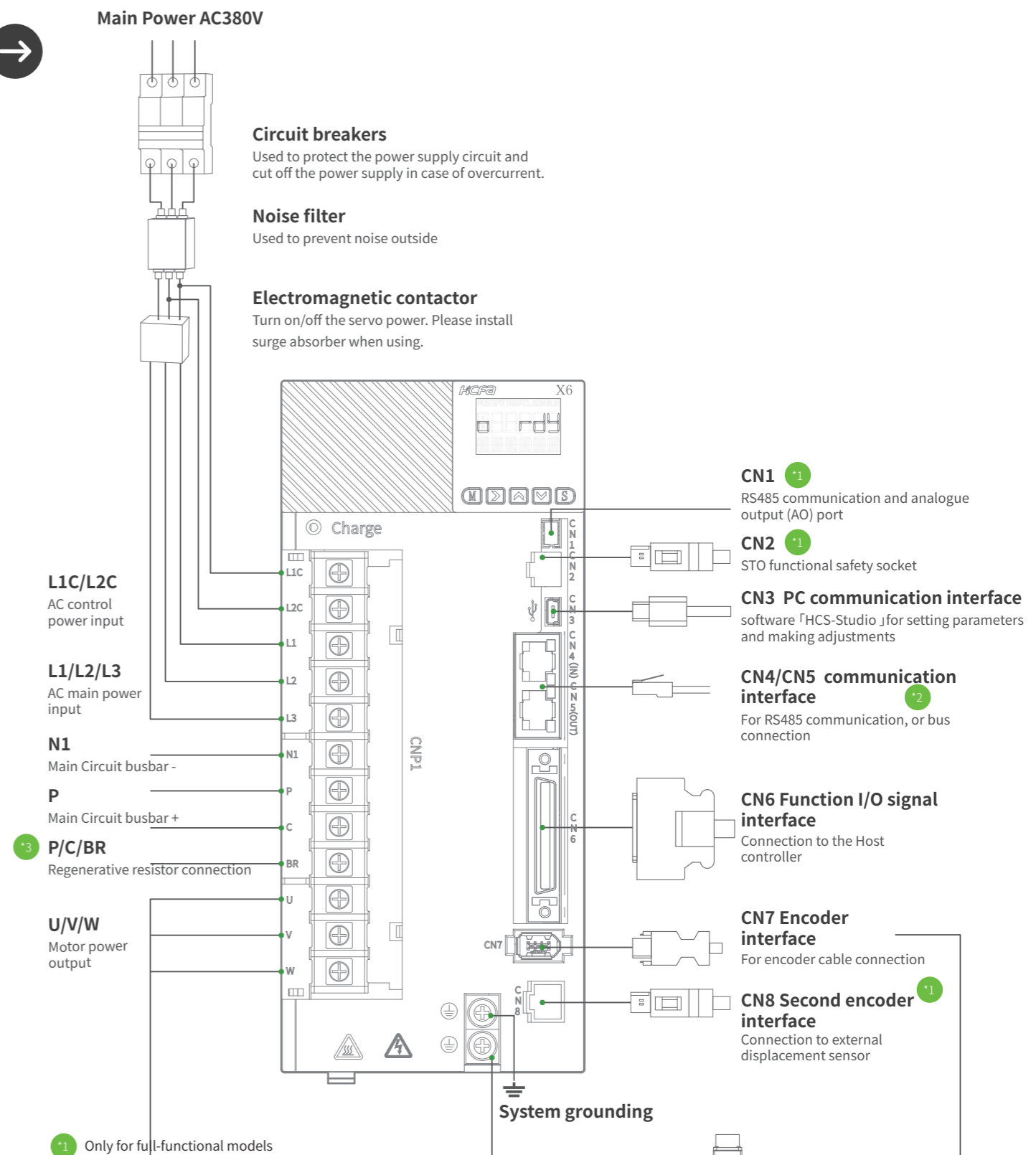

*1 Only for full-functional models

*2 Pulse type for RS485 communication
CANopen EtherCAT Pro finet models are used in bus communication interfaces

*3 P/C shorting required when using the driver's built-in regenerative resistor
When an external regenerative resistor is used, P/BR is inserted and the P/C stub is removed

External dimensions for 50W/100W/200W/400W Unit:mm

Weight (KG)
0.8

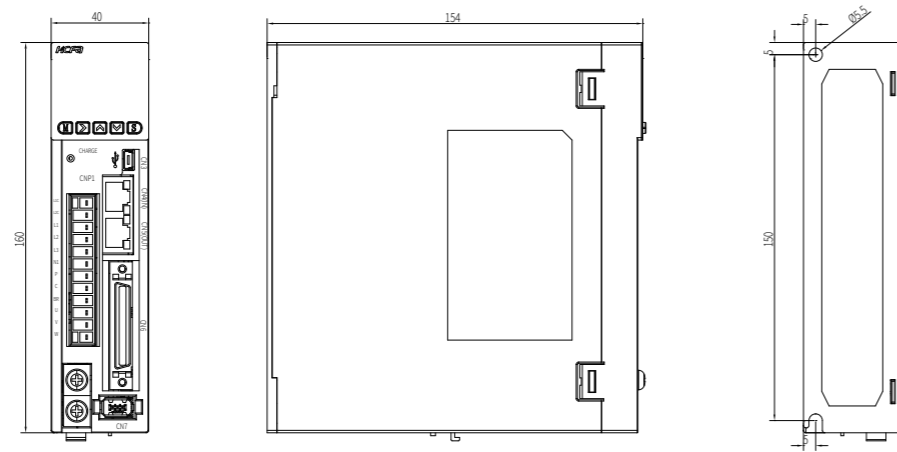

External dimensions for 2.5KW/3KW Unit:mm

Weight (KG)
1.7

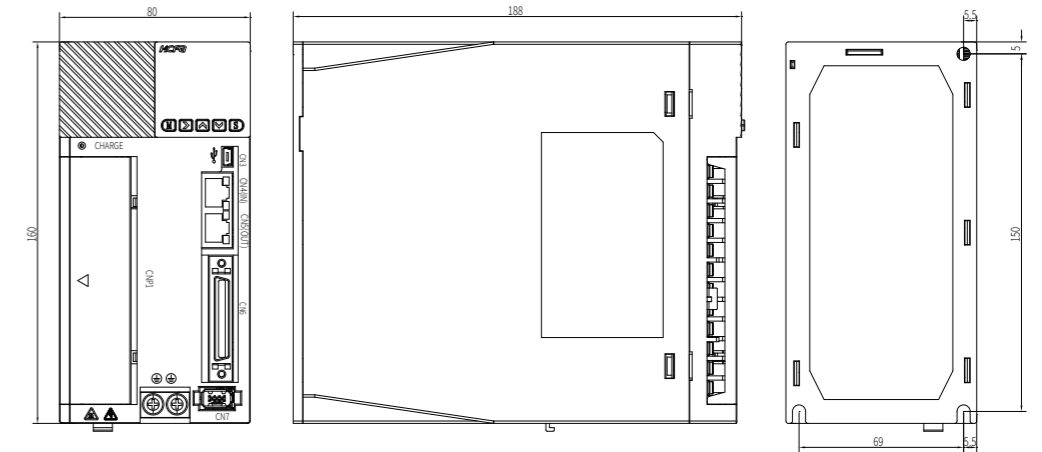

External dimensions for 750W/1KW Unit:mm

Weight (KG)
1

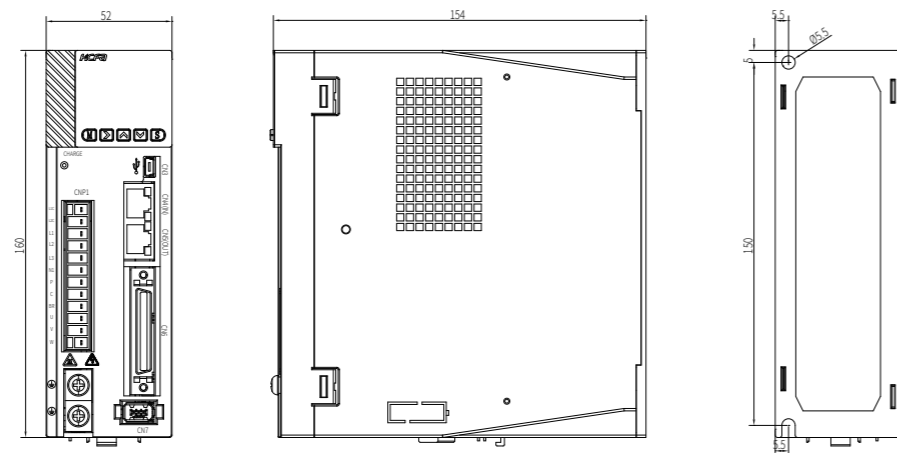

External dimensions for 5KW/7.5KW Unit:mm

Weight (KG)
3.1

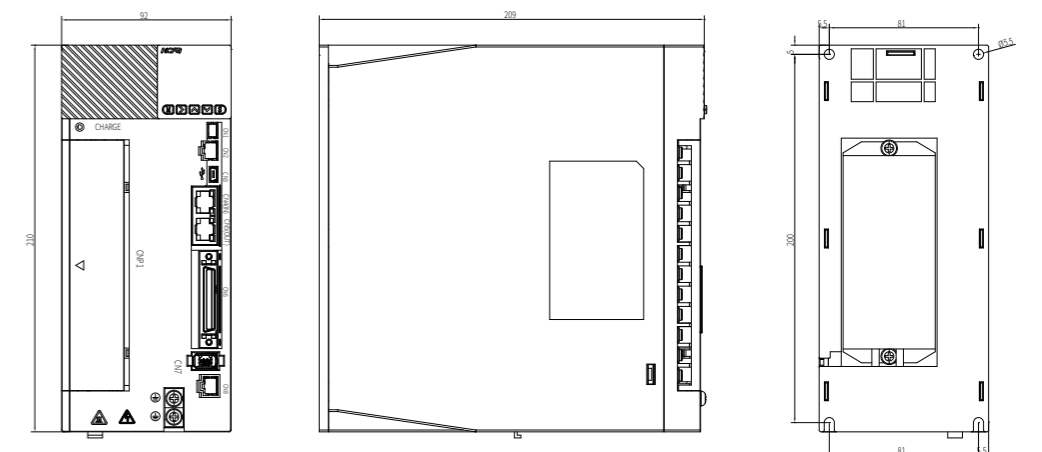

External dimensions for 1.5KW/2KW Unit:mm

Weight (KG)
1.5

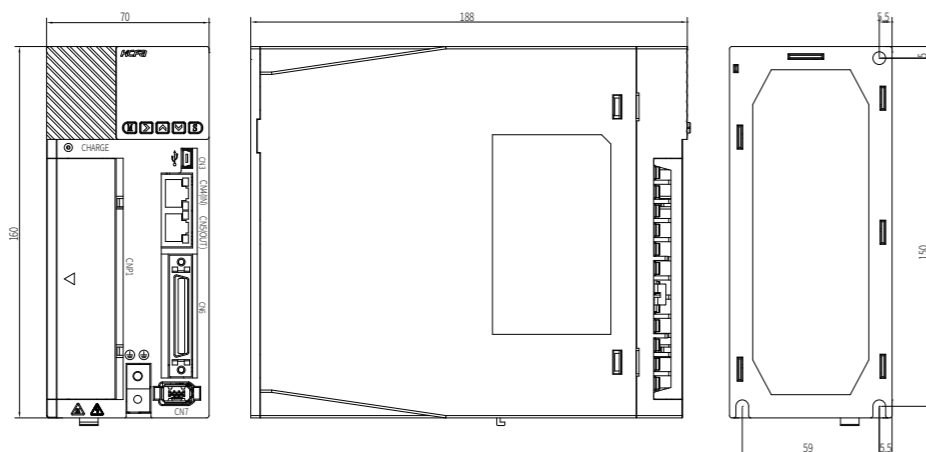

X5E Series Advanced Servo Drive

Naming Rule

SV-X5E B - 075 - A - A 0 - 00 000

1 2 3 4 5 6 7

1 Product Type	
A	Standard type
B	EtherCAT bus-type
N	CANopen bus-type

4 Control Power	
A	AC Power control

2 Product Power	
010	100W
040	400W
075	750W
100	1KW
150	1.5KW
200	2KW
250	2.5KW

5 Product Iteration Serial No.	
0	N/A

6 Hardware Type	
00	N/A
01	STO

3 Voltage Specification	
A	AC220V

7 Software Customised Mark	
000	N/A

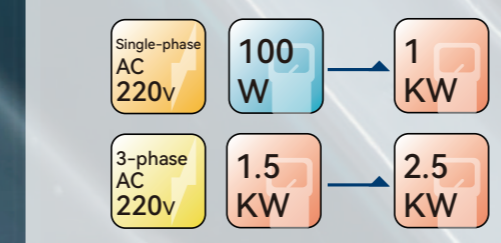

Compact size | Powerful Performance | Prominent Features

General Specifications

Item	Specifications						
Driver Type	010	040	075	100	150	200	250
Power (W)	100	400	750	1000	1500	2000	2500
Rated Current (Arms)	1.2	3	4.5	6	10	12.5	15.6
Continuous running current (Arms)	1.2	3	4.5	6	10	12.5	15.6
Max Output Current (Arms)	3.6	9	13.5	18	30	37.5	37.5
Power Specification	Single-phase 220V 50~60Hz			3-phase 220V 50~60Hz			
Control Mode	control modes: position control, speed control, torque control, position/speed control, position/torque control, speed/torque control.						
Applicable encoder	17bit/23bit						

Environment Specifications

Item	Specifications	
Temperature	Ambient temperature for use	0~55°C
	Ambient temperature for storage	-20~65°C
Humidity	Ambient temperature for use	20~85%RH or less(Without condensation)
	Ambient temperature for storage	20~85%RH or less(Without condensation)
Atmosphere for use& storage	Indoors(Not subject to direct sunlight); free from corrosive gas, flammable gas, oil mist, or dust	
Altitude	1000m or less above sea level	
Vibration	5.8m/s ² (0.6G) or less, 10~60Hz(No continuous operation allowed at frequency of resonance)	
Insulation and dielectric strength	1 minute at 1500 VAC across the primary and FG	

Technical Specifications

Item		Specifications		
Position Control	Pluse Input	Max Pluse frequency	Open-collector pulse input: Up to 200KHz, pulse width larger than 2.5us General input: Up to 500KHz, pulse width larger than 1 us High-speed input: Up to 4MHz, pulse width larger than 125ns	
		Input pulse form	Pulse + Directions, Phase A + Phase B, CW + CCW	
		Electronic gear setting	Electronic gear : A/B (Encoder resolution/10000000 < A/B < Encoder resolution/2.5)	
		Smoothing	Smoothing filters, FIR filters	
	Pluses Output	Output pulse function	Encoder position or pulse synchronisation output	
		Division ratio	Arbitrary frequency division	
		Output pulse form	Differential output: A/B/ Z, Open collector output: Z-phase	
	Internal position mode		Segment 1-16 internal position planning	
Speed Control	Control Method	Internal parameter P03.03 /1~16 segments speed selection can be realized by DI terminal combination		
	Torque Limiting Function	Internal parameter		
Torque Control	Control Method	Set the speed instruction value by P03.25		
	Speed Limiting Function	Set the positive and negative internal speed limit by P03.27, P03.28		
Common functions	Control signal	input/output	9IN/8OUT (busbar type 5IN/3OUT)	
	Speed monitoring function		Provided	
	Vibration control function		Provided	
	adaptive notch filter		Provided	
	Auto-tuning		Provided	
	Encoder output division and multiplication		Provided	
	dynamic brake		built-in	
	Regeneration function		A larger power braking resistor can be connected	
	protective function		Overvoltage, power supply error, overcurrent, overheat, overload, encoder error, over speed, position deviation too large, parameter error	
	communication function	USB	For PC communication (for "Servostudio" connection)	
Type		RS485	B:EtherCAT	N:CANOPEN



Circuit breakers

Used to protect the power supply circuit and cut off the power supply in case of overcurrent.

Noise filter

Used to prevent noise outside.

Electromagnetic contactor

Turn on/off the servo power. Please install surge absorber when using.

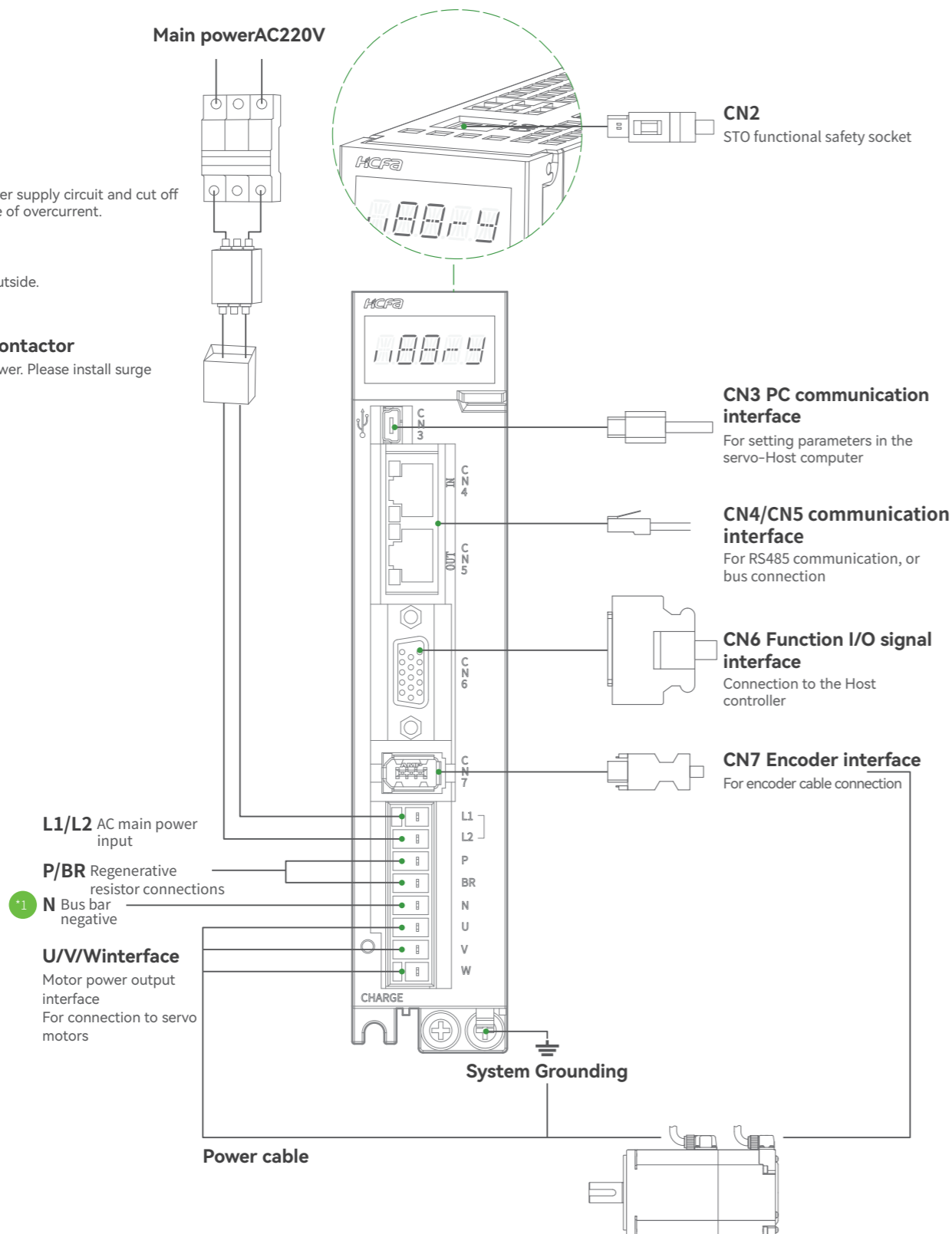

For using DC bus, do not connect the neutral line

External dimensions for 400W Unit: mm

Weight (KG)
0.75

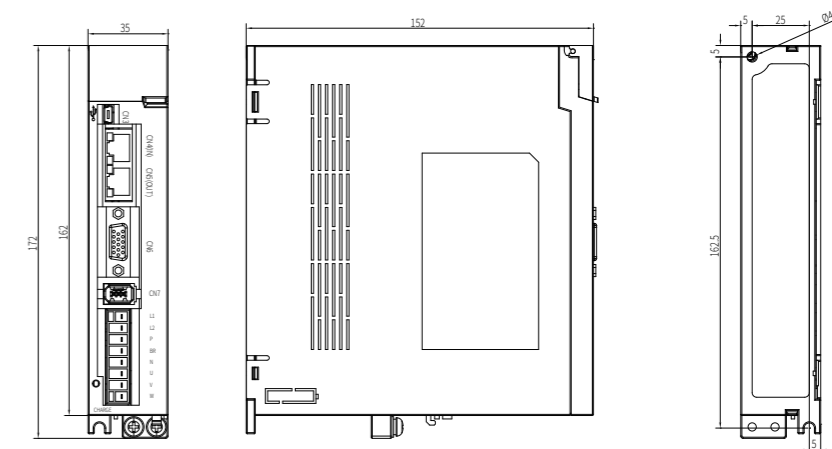

External dimensions for 750W/1KW Unit: mm

Weight (KG)
1.1

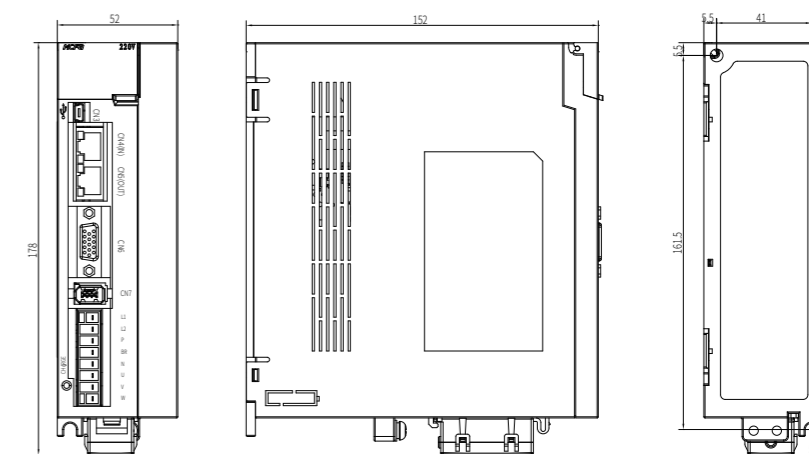

X2 Series

17BIT Absolute

50W-2.3KW
0.16N.m-15N.m

X6 Series

17BIT/23BIT Absolute

50W-7.5KW
0.16N.m-47.8N.m

Power specification

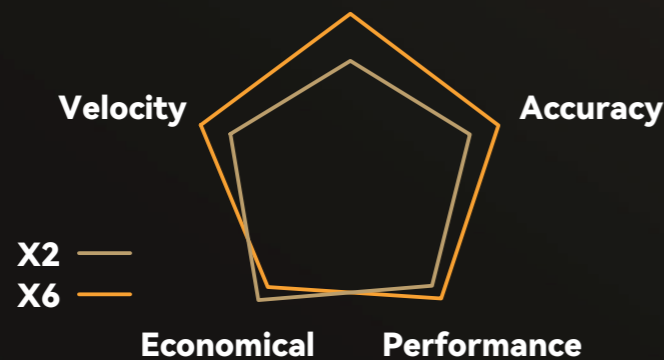

New manufacturing process

The newly-designed iron-core process makes the servo motor much smaller and lighter, 20% shorter than the previous generation

New structure design

The integrated structure of the front flange and housing to be stronger, matching with connector-type motor. IP67 protection level

New rotor design

The new design with 10-pole rotor + magnetic field analysis technology to reduce the width of pulsation and makes it smoother at low speed.



Full range of high, middle and low inertia!

MA

Low-inertia servo motor

Suitable for some occasions with light load and high-speed positioning. Quick response to start, accelerate and stop.

MM/MH

Medium/high inertia servo motor

Suitable for occasions with heavy load and high stability requirements.

MHH

Ultra-high inertia servo motor

Suitable for the same installation flange. With higher motor inertia, suitable for rollers and low-speed and stable occasions.

MQ

Flat and special flange servo motor

Under the same power, with different sizes of flange design. The servo motor becomes shorter, but with larger inertia. Also suitable for rollers and low-speed stable occasions.

MG

Low-speed and large-torque servo motor

With the characteristics of low rated speed and large output torque, suitable for heavy load occasions.

MGS

Low cogging cutting servo motor

Groove inclination design, which has lower cogging torque and good low-speed characteristics. At the same time, it can reach the maximum speed of 4000RPM with the Y7 series servo drive, which greatly shortens the idle travel time and improves the processing efficiency.

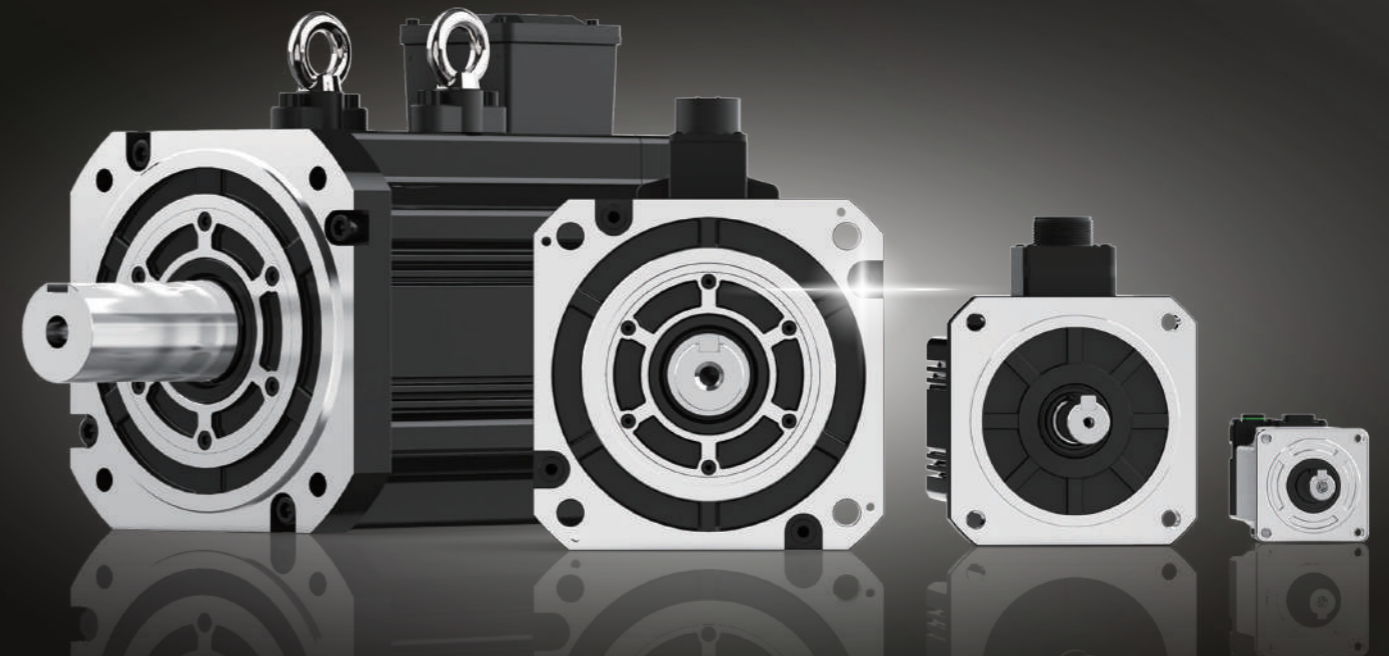

Naming Rule for X6 Series Servo Motor

SV-X6 MA 040 A - N 2 C D - ****

1 2 3 4 5 6 7 8 Special specifications

1 Product Series	
SV-X6 Series	17BIT/23BIT

2 Inertia Specifications	
MA	Low Inertia
MM	Medium Inertia
MH	High Inertia
MHH	Ultra-high Inertia
MQ	Special flange/Flat-type/small flange
MG	Low-speed & high-torque
MGS	Low cogging cutting

3 Power Specification			
005	50W	180	1.8KW
010	100W	200	2KW
015	150W	240	2.4KW
020	200W	290	2.9KW
040	400W	300	3KW
075	750W	400	4KW
085	850W	440	4.4KW
100	1KW	500	5KW
130	1.3KW	550	5.5KW
150	1.5KW	750	7.5KW

4 Design No.	
A/B/C/E/F/H/K/S	

5 Brake Specification	
N	No brake
B	With brake

6 Power Voltage Specification	
2	AC220V
4	AC380V

7 Specification	
K	Key shaft/no oil seal
L	Key shaft/oil seal
C	Connector type/key shaft/with oil seal*1
D	Connector type/key shaft/no oil seal*1
J	Compact (customized)

8 Encoder Specifications	
D	Multi-turn 23bit absolute
A	Multi-turn 17bit absolute

9 Customization	
**	N/A

E.g. 23bit absolute 220v 850W MG High torque at low speed naming rule SV-X6 MG 085A-N2LD
 23bit absolute 380v 850W MG High torque at low speed naming rule SV-X6 MG 085A-N4LD
 17bit absolute 380v 850W MG High torque at low speed naming rule SV-X6 MG 085A-N4LA

NOTE *1: From the 2nd quarter of 2021, our company started releasing connector-type servo motor with 40-80 flanges as the regular model.
 Lead-wire servo motors will be discontinued from December 2021, if still needed, the customized application process is required.
 For details, refer to page 55 or consult our sales staff.



X6 Series Servo Motor

Series	Specification	50W	100W	150W	200W	400W	750W	1.0KW	1.5KW	2.0KW	3.0KW	4.0KW	5.0KW	7.5KW
X6-MA Low Inert	Type				X6MA020A	X6MA040A	X6MA075A	X6MA100A	X6MA150A	X6MA200A				
	Flanges				60	60	80	100	100	100				
	Rated (peak torque) Inertia (no brakes) (brakes) Rotational speed: rated (max speed) 220V mot 380V mot				0.64 [1.91] 0.16 [0.17] 3000 [6000]	1.27 [3.82] 0.28 [0.29] 3000 [6000]	2.39 [7.16] 0.96 [1.07] 3000 [6000]	3.18 [9.55] 2.03 [2.35] 3000 [5000]	4.77 [14.3] 9.16 [10.4] 2000 [3000]	7.16 [21.5] 9.16 [10.4] 2000 [3000]	9.55 [28.6] 12.1 [13.3] 2000 [3000]			
X6-MM Medium Inertia	Type							X6MM100A	X6MM150A	X6MM200A	X6MM300A	X6MM400A	X6MM500A	X6MM750H
	Flanges							130	130	130	180	180	180	180
	Rated (peak torque) Inertia (no brakes) (brakes) Rotational speed: rated (max speed) 220V motor 380V mot							4.77 [14.3] 6.18 [7.4] 2000 [3000]	7.16 [21.5] 9.16 [10.4] 2000 [3000]	9.55 [28.6] 12.1 [13.3] 2000 [3000]	14.3 [42.9] 43.5 [63.2] 2000 [3000]	19.1 [57.3] 54.7 [68] 2000 [3000]	23.9 [71.6] 66.7 [80.8] 2000 [3000]	47.8 [119.4] 136.4 [150.8] 1500 [3000]
X6-MH High Inertia	Type								X6MH100A	X6MH150A	X6MH200A	X6MH400A		
	Flanges								130	130	180	180		
	Rated (peak torque) Inertia (no brakes) (brakes) Rotational speed: rated (max speed) 220V motor 380V mot								4.77 [14.3] 0.64 [2.23] 0.29 [0.31] 3000 [6500]	7.16 [21.5] 0.64 [2.23] 0.29 [0.31] 3000 [6500]	9.55 [28.6] 0.64 [2.23] 0.29 [0.31] 3000 [6500]	14.3 [42.9] 0.64 [2.23] 0.29 [0.31] 3000 [6500]	19.1 [57.3] 0.64 [2.23] 0.29 [0.31] 3000 [6500]	23.9 [71.6] 0.64 [2.23] 0.29 [0.31] 3000 [6500]
X6-MHH Ultra-high Inertia	Type													
	Flanges													
	Rated (peak torque) Inertia (no brakes) (brakes) Rotational speed: rated (max speed) 220V motor													
X6-MQ special flanges flat small fl	Type													
	Flanges													
	Rated (peak torque) Inertia (no brakes) (brakes) Rotational speed: rated (max speed) 220V motor													
Series Low-speed & high-torque	Type													
	Flanges													
	Rated (peak torque) Inertia (no brakes) (brakes) Rotational speed: rated (max speed) 220V motor 380V mot													
X6-MGS Low cogging cutting s	Type													
	Flanges													
	Rated (peak torque) Inertia (no brakes) (brakes) Rotational speed: rated (max speed) 220V motor 380V mot													

*1: From the 2nd quarter of 2021, our company started releasing connector-type servo motor with 40-80 flanges as the regular model.
 *2: Under development
 *3: Indicates there is no model with the brake.
 *4: The maximum speed of the servo motor varies due to the design difference of the servo drive

Servo Motor Specifications



Items	Unit	X6MA020A	X6MA040A	X6MA075A	X6MA100A	X6MA150A	X6MA200A	
Rated power	W	200	400	750	1000	1500	2000	
Rated voltage	V	220	220	220	220	220	220	
Fitting flange size	mm	60	60	80	100	100	100	
Rated torque	N.m	0.64	1.27	2.39	3.18	4.77	6.37	
Instantaneous max. torque	N.m	1.91	3.82	7.16	9.55	14.3	19.1	
Rated speed	r/min	3000	3000	3000	3000	3000	3000	
Max. speed	r/min	6000	6000	6000	5000	5000	5000	
Rated current	Arms	1.7	2.7	4.2	6.6	8.2	11.3	
Instantaneous max. current	Arms	6.5	10.2	17.4	28	35	48	
Moment of inertia	No brake	$\times 10^{-4}$ Kg.m ²	0.16	0.28	0.96	2.03	2.84	3.68
	With brake	$\times 10^{-4}$ Kg.m ²	0.17	0.29	1.07	2.35	3.17	4.01
Torque constant	N.m/A	0.427	0.488	0.583	0.52	0.628	0.607	
Induced voltage constant per phase	mV[r/min]	14.5	17.9	21.33	18.15	21.92	21.247	
Rated power rate	No brake	KW/S	25.6	57.6	59.5	49.82	80.12	110.26
	With brake	KW/S	24.1	55.6	53.4	43.03	71.775	101.19
Mechanical time constant	No brake	ms	0.775	0.561	0.463	0.619	0.507	0.425
	With brake	ms	0.824	0.581	0.516	0.717	0.566	0.463
Electrical time constant	ms	6.3	6.1	12.7	7.22	8.08	9.37	
Phase q-axis/d-axis inductance	mH	19/5.6	10.7/7.5	7.6/4.9	—	—	—	
Weight: No brake[with brake]	kg	0.9 [1.3]	1.28 [1.67]	2.25 [3.01]	3.5 [4.5]	4.4 [5.4]	5.3 [6.3]	
Permissible load	Radial load	N	245	245	392	392	392	
	Axial load	N	98	98	147	147	147	
Brake specification	Rated voltage	V	DC24V±10%					
	Rated current	A	0.36	0.36	0.42	0.81±10%	0.81±10%	0.81±10%
	Brake power	w	9	9	10	20	20	20
	Static friction torque	N.m	1.6 or more	1.6 or more	3.8 or more	7.8 or more	7.8 or more	7.8 or more
	Note: Holding brake	Suction time	ms	50 or less	50 or less	70 or less	50 or less	50 or less
	Release time	ms	20 or less	20 or less	20 or less	15 or less	15 or less	
	Release voltage	ms	DC1V or more					

Torque characteristics

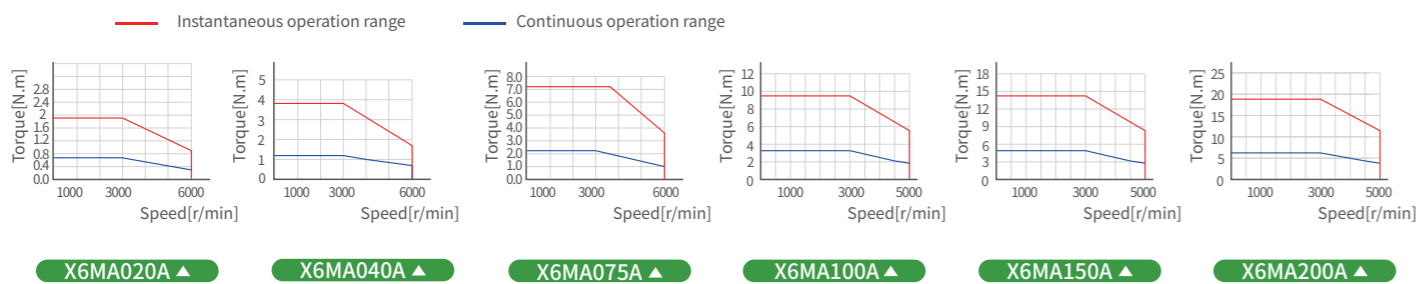

External Dimensions for Servo Motor

Unit(mm)

Models	X6MA020A	X6MA040A	X6MA075A	X6MA100A	X6MA150A	X6MA200A
LC	60	60	80	100	100	100
LA	φ70	φ70	φ90	φ115	φ115	φ115
LB	φ50	φ50	φ70	φ95	φ95	φ95
LZ	4-φ5.4	4-φ5.4	4-φ6	4-φ9	4-φ9	4-φ9
LR	30	30	35	55	55	55
S	φ14 h6	φ14 h6	φ19 h6	φ19 h6	φ19 h6	φ19 h6
LL no brake [with brake]	73.5 [103]	93.2[122.7]	105 [138.5]	123.5 [150.5]	142 [169]	161 [188]
LN no brake [with brake]	—	—	—	96.5 [123.5]	115 [142]	134 [161]
LG	6.5	6.5	8	10	10	10
LE	3	3	3	3	3	3
LM1 no brake [with brake]	—	—	—	111.5 [138.5]	130 [157]	149 [176]
LM2 no brake [with brake]	—	—	—	— [105]	— [123.5]	— [142.5]
LM3	—	—	—	62	80.5	99.5
LH1	44.5	44.5	54.5	103	103	103
LH2	—	—	—	66	66.5	66.5
LH3	—	—	—	55	55	55
LK	25	25	25	42	42	42
T	5	5	6	6	6	6
KW	5 h9	5 h9	6 h9	6 h9	6 h9	6 h9
KH	11	11	15.5	15.5	15.5	15.5
TP	M5depth12	M5depth12	M5depth10	M5depth12	M5depth12	M5depth12
H	Cable length for lead-wire type	210	210	210	—	—

X6MA020A / X6MA040A / X6MA075A

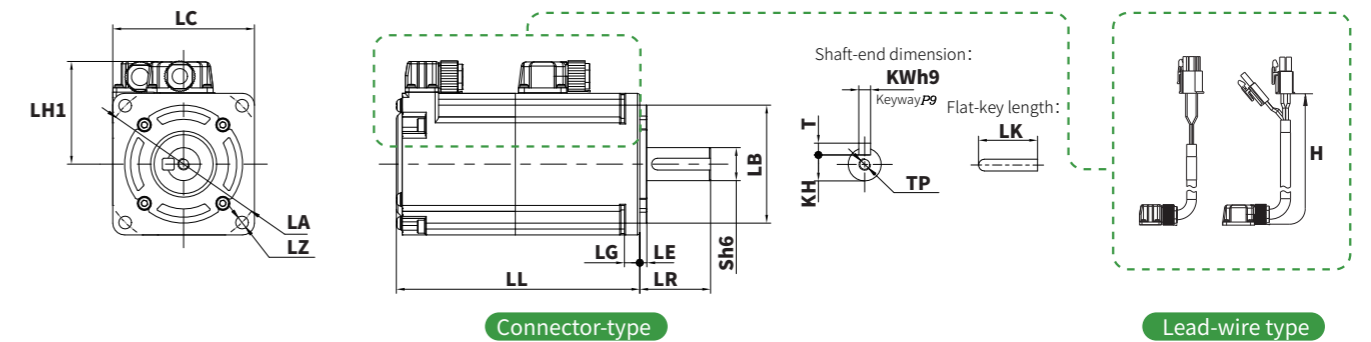

X6MA100A / X6MA150A / X6MA200A

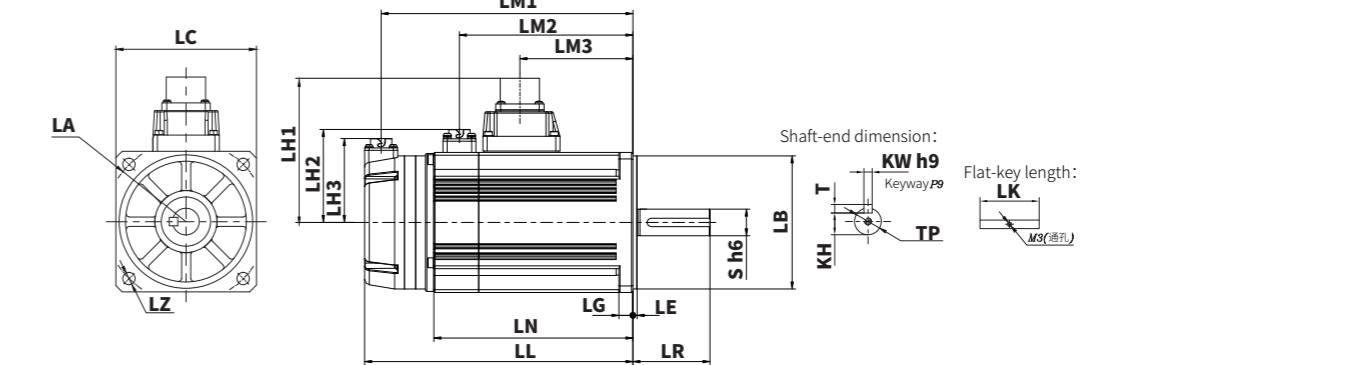

*1: For X6 series servo motors, the lead-wire types are needed to be customized. For details, please contact our sales department.

Servo Motor Specifications

1 KW 1.5 KW 2 KW

Items	Unit	X6MM100A	X6MM150A	X6MM200A	
Rated power	W	1000	1500	2000	
Rated voltage	V	220	220	220	
Fitting flange size	mm	130	130	130	
Rated torque	N.m	4.77	7.16	9.55	
Instantaneous max. torque	N.m	14.3	21.5	28.6	
Rated speed	r/min	2000	2000	2000	
Max. speed	r/min	3000	3000	3000	
Rated current	Arms	5.2	8	9.9	
Instantaneous max. current	Arms	15.6	24	30	
Moment of inertia	No brake	$\times 10^{-4} \text{Kg.m}^2$	6.18	9.16	12.1
	With brake	$\times 10^{-4} \text{Kg.m}^2$	7.4	10.4	13.3
Torque constant	N.m/A	0.918	0.895	0.9645	
Induced voltage constant per phase	mV[r/min]	33.65	34.84	37.95	
Rated power rate	No brake	KW/S	36.8	56	75.4
	With brake	KW/S	30.7	49.3	68.6
Mechanical time constant	No brake	ms	1.51	1.16	1.05
	With brake	ms	1.81	1.3	1.16
Electrical time constant	ms	11.1	14.6	15.38	
Phase q-axis/d-axis inductance	mH	8.4/4.3	5.8/2.9	4.9/2.6	
Weight: No brake[with brake]	kg	4.67 [6.27]	5.87 [7.47]	12.1 [13.3]	
Permissible load	Radial load	N	490	490	490
	Axial load	N	196	196	196
Brake specification	Rated voltage	V	DC24V±10%		
	Rated current	A	0.9	0.9	0.9
	Brake power	w	22	22	22
	Static friction torque	N.m	14 or more	14 or more	14 or more
Note: Holding brake	Suction time	ms	100 or less	100 or less	100 or less
	Release time	ms	60 or less	60 or less	60 or less
	Release voltage	ms	DC1V or more		

External Dimensions for Servo Motor

Unit(mm)

Models	X6MM100A	X6MM150A	X6MM200A
LC	130	130	130
LA	φ145	φ145	φ145
LB	φ110	φ110	φ110
LZ	4-φ9	4-φ9	4-φ9
LR	55	55	55
S	φ22 h6	φ22 h6	φ22 h6
LL no brake [with brake]	128 [148]	142 [162]	156 [176]
LN no brake [with brake]	80 [100]	94 [114]	108 [128]
LG	12	12	12
LE	6	6	6
LM1 no brake [with brake]	116.2 [136.2]	130.2 [150.2]	144.2 [164.2]
LM3	41	55	69
LH1	115	115	115
LH3	60	60	60
LK	45	45	45
T	7	7	7
KW	8 h9	8 h9	8 h9
KH	18	18	18
TP	M6depth20	M6depth20	M6depth20

X6MM100A / X6MM150A / X6MM200A

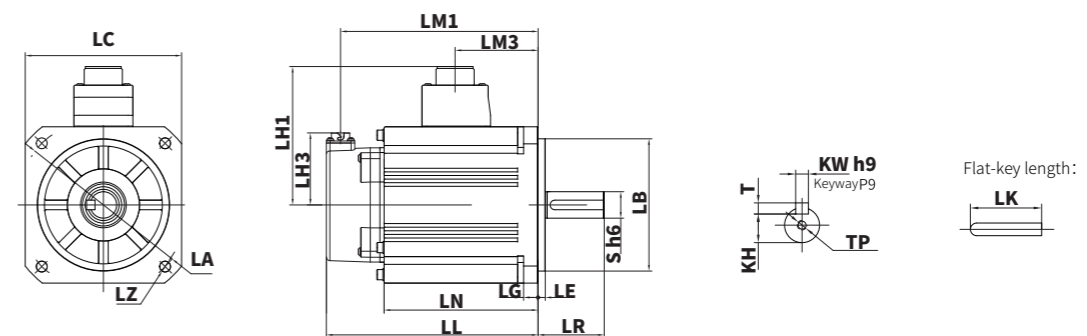

Torque characteristics

Instantaneous operation range Continuous operation range

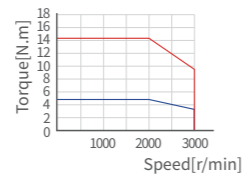

X6MM100A▲



X6MM150A▲



X6MM200A▲

Servo Motor Specifications



Items	Unit	X6MH005A	X6MH010A	X6MH015A	X6MH020A*2	
Rated power	W	50	100	150	200	
Rated voltage	V	220	220	220	220	
Fitting flange size	mm	40	40	40	60	
Rated torque	N.m	0.16	0.32	0.477	0.64	
Instantaneous max. torque	N.m	0.56	1.11	1.43	2.23	
Rated speed	r/min	3000	3000	3000	3000	
Max. speed	r/min	6500	6500	6000	6500	
Rated current	Arms	1.1	1.1	1.5	1.4	
Instantaneous max. current	Arms	3.89	3.89	4.5	4.87	
Moment of inertia	No brake	$\times 10^{-4} \text{Kg.m}^2$	0.038	0.071	0.13	0.29
	With brake	$\times 10^{-4} \text{Kg.m}^2$	0.042	0.074	0.133	0.31
Torque constant	N.m/A	0.168	0.327	0.33	0.5	
Induced voltage constant per phase	mV[r/min]	5	11.1	12.2	14.61	
Rated power rate	No brake	KW/S	6.7	14.4	17.5	14.1
	With brake	KW/S	6.1	13.8	17.1	13.2
Mechanical time constant	No brake	ms	2.6	1.67	1.9	1.57
	With brake	ms	2.85	1.74	1.94	1.68
Electrical time constant	ms	0.89	1.1	1.22	2.58	
Phase q-axis/d-axis inductance	mH	5.1/3.4	9.4/6.3	7.2/4.8	10.2/5.8	
Weight: No brake[with brake]	kg	0.33 [0.55]	0.45 [0.66]	0.83 [0.69]	0.87 [1.27]	
Permissible load	Radial load	N	68	68	68	245
	Axial load	N	58	58	58	98
Brake specification	Rated voltage	V	DC24V \pm 10%			
	Rated current	A	0.25	0.25	0.375	0.36
	Brake power	w	6	6	9	9
	Static friction torque	N.m	0.38 or more	0.38 or more	0.58 or more	1.6 or more
Note: Holding brake	Suction time	ms	35 or less	35 or less	50 or less	50 or less
	Release time	ms	20 or less	20 or less	20 or less	20 or less
	Release voltage	ms	DC1V or more			

External Dimensions for Servo Motor

Unit(mm)

Models	X6MH005A	X6MH010A	X6MH015A	X6MH020A*2
LC	40	40	40	60
LA	$\phi 46$	$\phi 46$	$\phi 46$	$\phi 70$
LB	$\phi 30$	$\phi 30$	$\phi 30$	$\phi 50$
LZ	2- $\phi 4.3$	2- $\phi 4.3$	2- $\phi 4.3$	4- $\phi 5.4$
LR	25	25	25	30
S	$\phi 8 \text{ h6}$	$\phi 8 \text{ h6}$	$\phi 8 \text{ h6}$	$\phi 14 \text{ h6}$
LL no brake [with brake]	57 [91]	71 [105]	93.8 [127.8]	70.5 [100]
LG	5	5	5	6.5
LE	3	3	3	3
LH	35	35	35	44.5
LK	14	14	14	25
T	3	3	3	5
KW	3 h9	3 h9	3 h9	5 h9
KH	6.2	6.2	6.2	11
TP	M3depth6	M3depth6	M3depth6	M5depth 12
H Cable length for lead-wire type	210	210	210	210

X6MH005A / X6MH010A / X6MH015A / X6MH020A

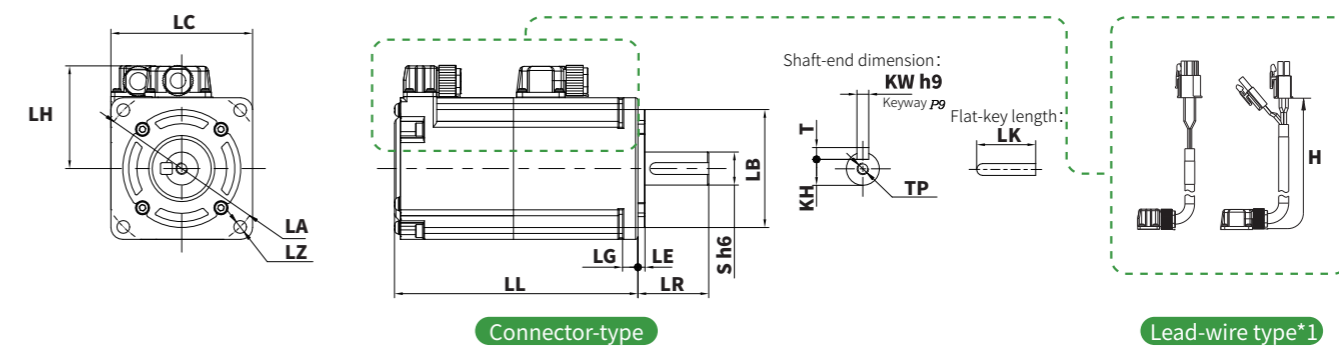

*1: For X6 series servo motors, the lead-wire types are needed to be customized. For details, please contact our sales department.

Torque characteristics

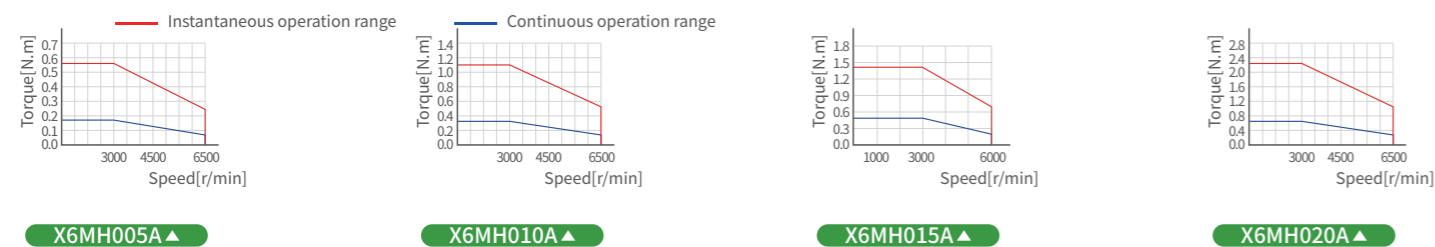

Servo Motor Specifications

400 W 750 W 1 KW 1.5 KW

Items	Unit	X6MH040A	X6MH075A	X6MH100A	X6MH150A	
Rated power	W	400	750	1000	1500	
Rated voltage	V	220	220	220	220	
Fitting flange size	mm	60	80	130	130	
Rated torque	N.m	1.27	2.39	4.77	7.16	
Instantaneous max. torque	N.m	4.46	8.36	14.3	21.5	
Rated speed	r/min	3000	3000	2000	2000	
Max. speed	r/min	6500	6000	3000	3000	
Rated current	Arms	2.1	3.8	5.2	8	
Instantaneous max. current	Arms	7.36	13.3	15.6	24	
Moment of inertia	No brake	$\times 10^{-4} \text{Kg.m}^2$	0.56	1.56	30.8	38.5
	With brake	$\times 10^{-4} \text{Kg.m}^2$	0.58	1.66	32	39.7
Torque constant	N.m/A	0.67	0.648	0.918	0.895	
Induced voltage constant per phase	mV[r/min]	20.85	22.65	33.65	34.84	
Rated power rate	No brake	KW/S	28.8	36.6	7.39	13.3
	With brake	KW/S	27.8	34.4	7.11	12.9
Mechanical time constant	No brake	ms	1.24	0.97	7.54	4.9
	With brake	ms	1.29	1.03	7.84	5.05
Electrical time constant	ms	2.97	6.59	11.1	14.63	
Phase q-axis/d-axis inductance	mH	9.2/6.5	6/3.3	8.4/4.3	5.8/2.9	
Weight: No brake[with brake]	kg	1.22 [1.61]	2.25 [3.01]	6.4[8.0]	7.8[9.4]	
Permissible load	Radial load	N	245	392	490	490
	Axial load	N	98	147	196	196
Brake specification	Rated voltage	V	DC24V \pm 10%			
	Rated current	A	0.36	0.42	0.9	0.9
	Brake power	w	9	9	9	9
	Static friction torque	N.m	1.6 or more	3.8 or more	14 or more	14 or more
Note: Holding brake	Suction time	ms	50 or less	70 or less	100 or less	100 or less
	Release time	ms	20 or less	20 or less	60 or less	60 or less
	Release voltage	ms	DC1V or more			

External Dimensions for Servo Motor

Unit(mm)

Models	X6MH040A	X6MH075A	X6MH100A	X6MH150A
LC	60	80	130	130
LA	$\phi 70$	$\phi 90$	$\phi 145$	$\phi 145$
LB	$\phi 50$	$\phi 70$	$\phi 110$	$\phi 110$
LZ	4- $\phi 5.4$	4- $\phi 6.5$	4- $\phi 9$	4- $\phi 9$
LR	30	35	55	55
S	$\phi 14 \text{ h6}$	$\phi 19 \text{ h6}$	$\phi 22 \text{ h6}$	$\phi 22 \text{ h6}$
LL no brake [with brake]	87.5 [117]	94.5 [128.5]	156 [176]	170 [190]
LN no brake [with brake]	—	—	108 [128]	122 [142]
LG	6.5	8	12	12
LE	3	3	6	6
LM1 no brake [with brake]	—	—	144.2[164.2]	158.2 [178.2]
LM3	—	—	69	83
LH1	44.5	54.5	115	115
LH3	—	—	60	60
LK	25	25	45	45
T	5	6	7	7
KW	5 h9	6 h9	8 h9	8 h9
KH	11	15.5	18	18
TP	M5depth12	M5depth12	M6depth20	M6depth20
H	H-type cable length for lead-wire type	210	210	—

X6MH040A / X6MH075A

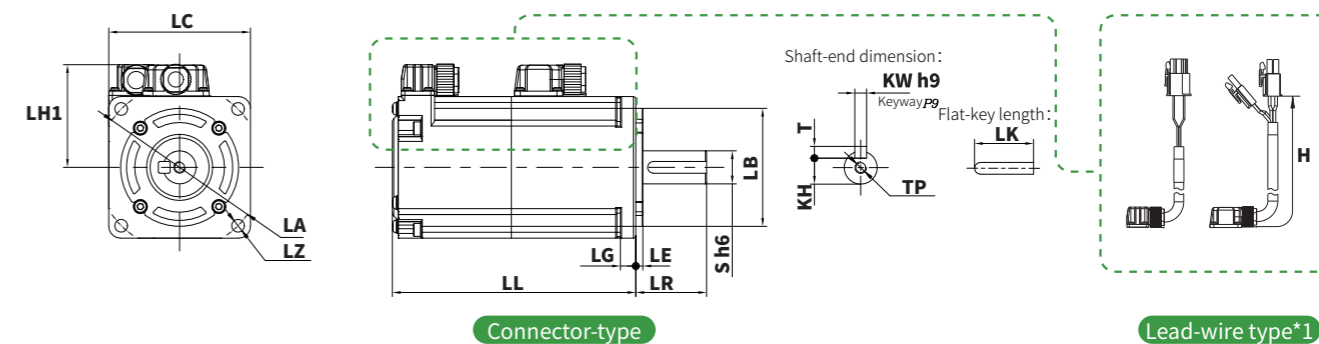

X6MH100A / X6MH150A

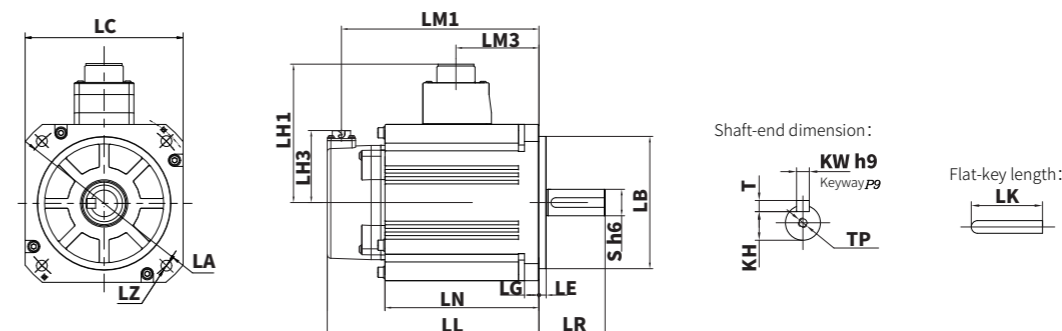

*1: For X6 series servo motors, the lead-wire types are needed to be customized. For details, please contact our sales department.

Torque characteristics

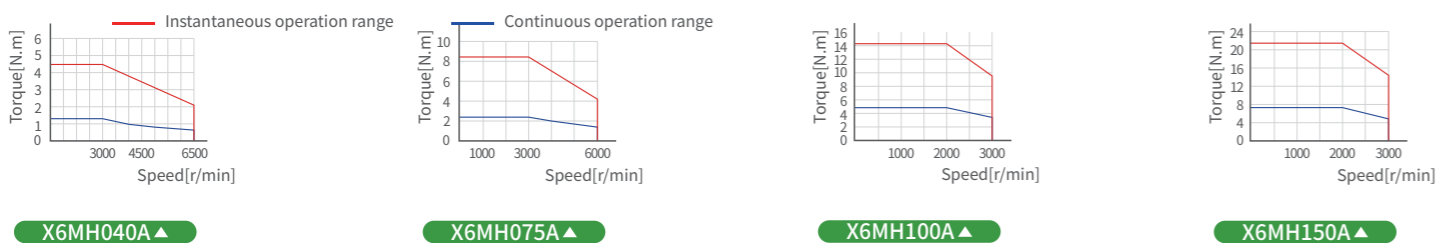

Servo Motor Specifications 100W 200W 400W 750W

Items	Unit	X6MH010H	X6MH020H	X6MH040H	X6MH075H	
Rated power	W	100	200	400	750	
Rated voltage	V	220	220	220	220	
Fitting flange size	mm	40	60	60	80	
Rated torque	N.m	0.32	0.64	1.27	2.39	
Instantaneous max. torque	N.m	1.11	2.23	4.46	8.36	
Rated speed	r/min	3000	3000	3000	3000	
Max. speed	r/min	6500	6500	6500	6000	
Rated current	Arms	0.92	1.4	2.4	3.8	
Instantaneous max. current	Arms	3.6	6.9	8.2	18.8	
Moment of inertia	No brake	$\times 10^{-4} \text{Kg.m}^2$	0.092	0.47	0.73	3.15
	With brake	$\times 10^{-4} \text{Kg.m}^2$	0.095	0.49	0.75	—*2
Torque constant	N.m/A	0.327	0.5	0.531	0.648	
Induced voltage constant per phase	mV[r/min]	13.3	14.61	20.4	22.65	
Rated power rate	No brake	KW/S	11.13	8.71	22.09	18.1
	With brake	KW/S	10.78	8.36	21.5	17.85
Mechanical time constant	No brake	ms	2.23	2.54	1.15	1.95
	With brake	ms	2.3	2.65	1.18	1.98
Electrical time constant	ms	0.986	2.58	4.1	6.59	
Phase q-axis/d-axis inductance	mH	11.9/8	10.2/5.8	6.9/4.3	6/3.3	
Weight: No brake[with brake]	kg	0.44[0.65]	0.95 [1.29]	1.45 [1.85]	2.65 [—*2]	
Permissible load	Radial load	N	68	245	245	392
	Axial load	N	58	98	98	147
Brake specification	Rated voltage	V	DC24V±10%			
	Rated current	A	0.25	0.36	0.36	0.42
	Brake power	w	6	9	9	10
	Static friction torque	N.m	0.38 or more	1.6 or more	1.6 or more	3.8 or more
Note: Holding brake	Suction time	ms	35 or less	50 or less	50 or less	70 or less
	Release time	ms	20 or less	20 or less	20 or less	20 or less
	Release voltage	ms	DC1V or more			

External Dimensions for Servo Motor Unit(mm)

Models	X6MH010H	X6MH020H(Lead-wire type)	X6MH040H	X6MH075H(Lead-wire type)
LC	40	60	60	80
LA	φ46	φ70	φ70	φ90
LB	φ30	φ50	φ50	φ70
LZ	2-φ4.3	4-φ5.5	4-φ5.5	4-φ6.6
LR	25	30	30	35
S	φ8 h6	φ14 h6	φ14 h6	φ19 h6
LL no brake [with brake]	76.7 [110.7]	82.4 [111.9]	98.5 [128]	122 [—*2]
LG	5	6.5	6.5	8
LE	3	3	3	3
LH1	34.5	43.5	43.5	53.5
LK	14	25	25	25
T	3	5	5	6
KW	3 h9	5 h9	5 h9	6 h9
KH	6.2	11	11	15.5
TP	M3depth6	M5depth12	M5depth12	M5depth12
H	H-type cable length for lead-wire type	210	210	210

▼ X6MH010H / X6MH020H / X6MH040H / X6MH075H

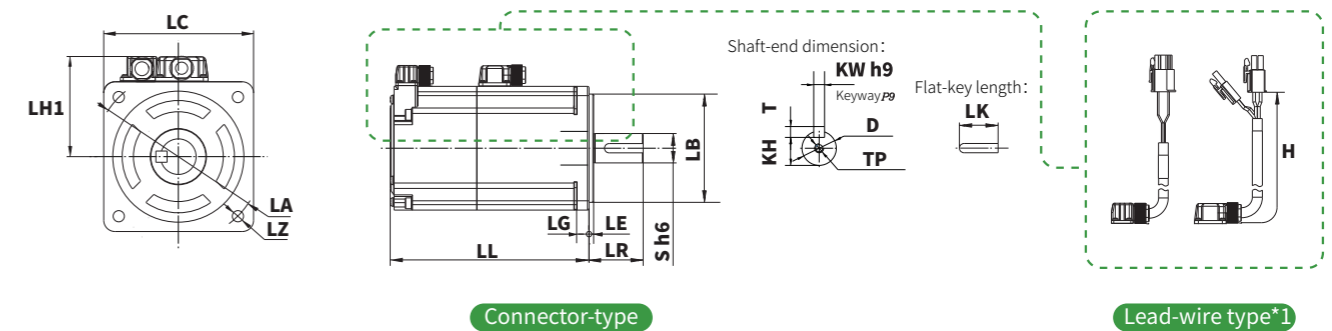

*1: For X6 series servo motors, the lead-wire types are needed to be customized. For details, please contact our sales department.

Torque characteristics

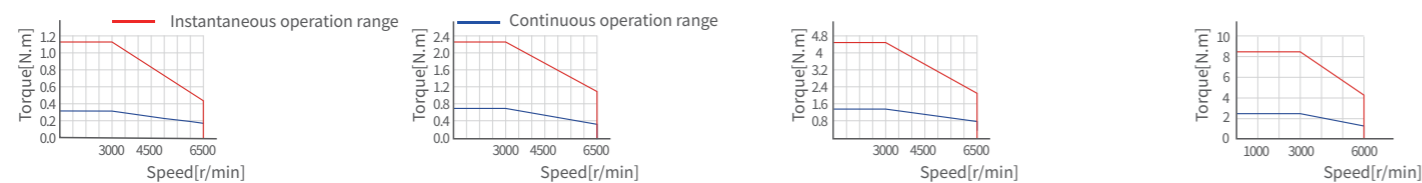

X6MH010H ▲ X6MH020H ▲ X6MH040H ▲ X6MH075H ▲

Servo Motor Specifications 100 W 200 W 400 W 1 KW

Items	Unit	X6MQ010A	X6MQ020A	X6MQ040A	X6MQ100E	
Rated power	W	100	200	400	1000	
Rated voltage	V	220	220	220	220	
Fitting flange size	mm	60	80	80	80	
Rated torque	N.m	0.32	0.637	1.27	3.185	
Instantaneous max. torque	N.m	0.96	1.91	3.82	11.13	
Rated speed	r/min	3000	3000	3000	3000	
Max. speed	r/min	6500	6500	6500	6000	
Rated current	Arms	0.95	2	2.6	5.7	
Instantaneous max. current	Arms	2.8	6.4	8.4	21.2	
Moment of inertia	No brake	$\times 10^{-4} \text{Kg.m}^2$	0.16	0.47	0.87	2
	With brake	$\times 10^{-4} \text{Kg.m}^2$	0.18	0.5	0.9	2.1
Torque constant	N.m/A	0.369	0.318	0.488	0.552	
Induced voltage constant per phase	mV[r/min]	11.6	12.2	19.6	21.2	
Rated power rate	No brake	KW/S	6.4	8.63	18.5	50.7
	With brake	KW/S	5.69	8.12	17.92	48.31
Mechanical time constant	No brake	ms	2.96	2.51	1.51	0.85
	With brake	ms	3.33	2.67	1.57	0.897
Electrical time constant	ms	1.76	3.52	5.41	7.6	
Phase q-axis/d-axis inductance	mH	13.9/7.8	7.3/3.9	9/4.9	3.8/2.6	
Weight: No brake[with brake]	kg	0.68 [0.92]	1.24 [1.74]	1.6 [2.1]	2.68 [3.45]	
Permissible load	Radial load	N	68	245	245	392
	Axial load	N	58	98	98	147
Brake specification	Rated voltage	V	DC24V±10%			
	Rated current	A	0.9	0.9	0.9	0.42
	Brake power	w	22	22	22	22
	Static friction torque	N.m	0.38-1.1	1.6 or more	1.6 or more	3.8 or more
Note: Holding brake	Suction time	ms	60 or less	60 or less	60 or less	70 or less
	Release time	ms	40 or less	40 or less	40 or less	20 or less
	Release voltage	ms	DC1.5V or more			DC1V or more

Torque characteristics

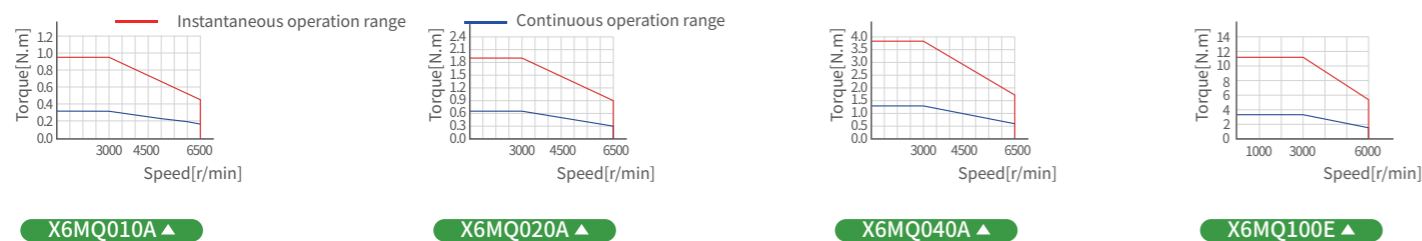

External Dimensions for Servo Motor Unit(mm)

Models	X6MQ010A(Lead-wire type)	X6MQ020A(Lead-wire type)	X6MQ040A(Lead-wire type)	X6MQ100E
LC	60	80	80	80
LA	φ70	φ90	φ90	φ90
LB	φ50	φ70	φ70	φ70
LZ	4-φ5.4	4-φ6	4-φ6	4-φ6.5
LR	25	30	30	35
S	φ8 h6	φ11 h6	φ14 h6	φ19 h6
LL no brake [with brake]	61 [80.5]	66 [90]	76.8 [100.8]	108 [141.5]
LG	6.5	8	8	8
LE	3	3	3	3
LF	21	26	26	—
LP	φ14	φ19.7	φ19.7	—
LH1	43.5	53.5	53.5	53.5
LK	14	20	22	25
T	3	4	5	6
KW	3 h9	4 h9	5 h9	6 h9
KH	6.2	8.5	11	15.5
TP	M3depth6	M4depth8	M5depth12	M5depth12
H	H-type cable length for lead-wire type	210	210	210

X6MQ010A / X6MQ020A / X6MQ040A / X6MQ100E

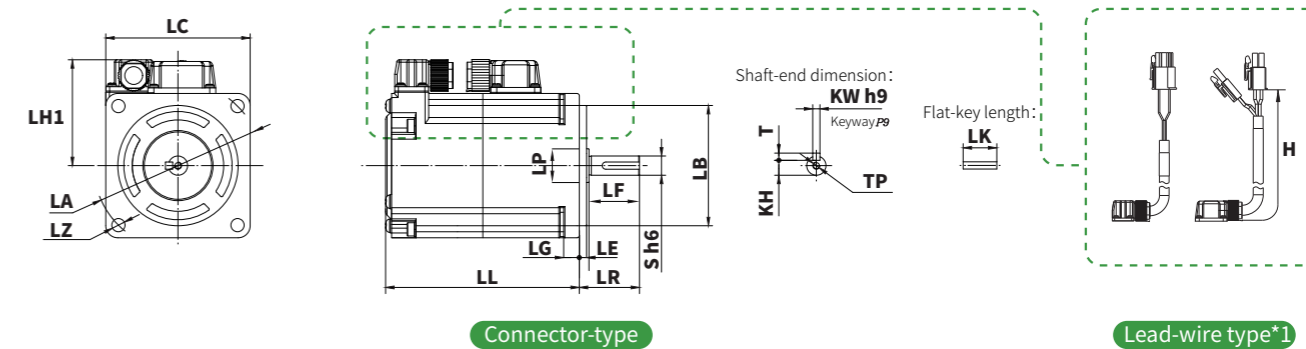

*1: For X6 series servo motors, the lead-wire types are needed to be customized. For details, please contact our sales department.

Servo Motor Specifications

850 W 1 KW 1.3 KW 1.8 KW

Items	Unit	X6MG075A	X6MG085A	X6MG100A	X6MG130A	X6MG180A	
Rated power	W	750	850	1000	1300	1800	
Rated voltage	V	220	220	220	220	220	
Fitting flange size	mm	80	130	130	130	130	
Rated torque	N.m	4.77	5.41	9.55	8.28	11.5	
Instantaneous max. torque	N.m	14.3	16.2	28.6	24.84	34.5	
Rated speed	r/min	1500	1500	1000	1500	1500	
Max. speed	r/min	2000	3000	1500	3000	3000	
Rated current	Arms	4.2	5.9	5.2	9.3	11.8	
Instantaneous max. current	Arms	15	18	16	28	35.5	
Moment of inertia	No brake	$\times 10^{-4} \text{Kg.m}^2$	2.88	14	12.1	20.2	26
	With brake	$\times 10^{-4} \text{Kg.m}^2$	3	15.2	13.3	21.4	27.2
Torque constant	N.m/A	1.135	0.918	1.83	0.895	0.964	
Induced voltage constant per phase	mV[r/min]	43.3	33.65	67.3	34.84	40.18	
Rated power rate	No brake	KW/S	79	63.29	75.4	33.9	50.87
	With brake	KW/S	75.84	58.26	68.6	32	48.6
Mechanical time constant	No brake	ms	1.01	3.43	1.12	2.57	2.06
	With brake	ms	1.05	3.72	1.23	2.72	2.15
Electrical time constant	ms	5.1	11.1	9.65	14.63	15.99	
Phase q-axis/d-axis inductance	mH	8.4/5.7	8.4/4.3	11/8.7	5.8/2.9	4.9/2.6	
Weight: No brake[with brake]	kg	3.46 [4.14]	5.53 [7.13]	6.91 [8.51]	6.89 [8.49]	8.14 [9.74]	
Permissible load	Radial load	N	392	490	490	490	
	Axial load	N	147	160	160	160	
Brake specification	Rated voltage	V	DC24V \pm 10%				
	Rated current	A	0.42	0.9	0.9	0.9	
	Brake power	w	10	10	10	10	
	Static friction torque	N.m	3.8 or more	14 or more	14 or more	14 or more	14 or more
Note: Holding brake	Suction time	ms	70 or less	100 or less	100 or less	100 or less	
	Release time	ms	20 or less	60 or less	60 or less	60 or less	
	Release voltage	ms	DC1V or more				

Torque characteristics

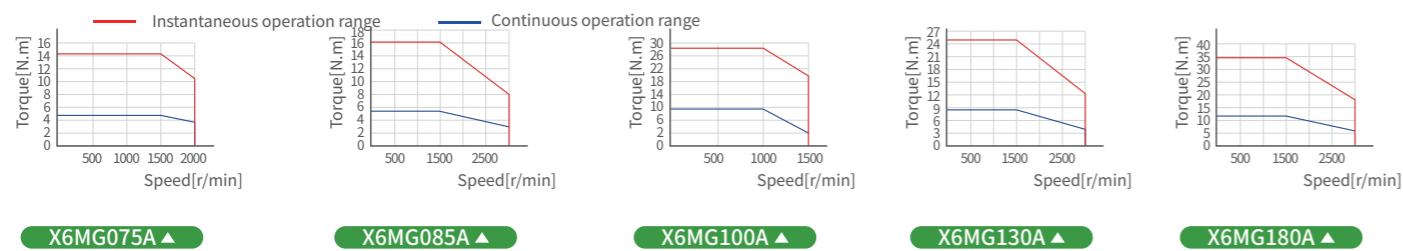

External Dimensions for Servo Motor

Unit(mm)

Models	X6MG075A(Lead-wire type)	X6MG085A	X6MG100A	X6MG130A	X6MG180A
LC	80	130	130	130	130
LA	$\phi 90$	$\phi 145$	$\phi 145$	$\phi 145$	$\phi 145$
LB	$\phi 70$	$\phi 110$	$\phi 110$	$\phi 110$	$\phi 110$
LZ	4- $\phi 6.6$	4- $\phi 9$	4- $\phi 9$	4- $\phi 9$	4- $\phi 9$
LR	35	55	55	55	55
S	$\phi 19 \text{ h6}$	$\phi 22 \text{ h6}$	$\phi 22 \text{ h6}$	$\phi 22 \text{ h6}$	$\phi 22 \text{ h6}$
LL no brake [with brake]	134 [177]	156 [176]	156 [176]	170 [190]	184 [204]
LN no brake [with brake]	—	108 [128]	108 [128]	122 [142]	136 [156]
LG	8	12	12	12	12
LE	3	6	6	6	6
LM1 no brake [with brake]	—	144.2[164.2]	144.2 [164.2]	158.2 [178.2]	172.2[192.2]
LM3	—	69	69	83	97
LH1	54	115	115	115	115
LH3	—	60	60	60	60
LK	25	45	45	45	45
T	6	7	7	7	7
KW	6 h9	8 h9	8 h9	8 h9	8 h9
KH	15.5	18	18	18	18
TP	M5depth12	M6depth20	M6depth20	M6depth20	M6depth20
H Cable length for lead-wire type	210	—	—	—	—

X6MG075A

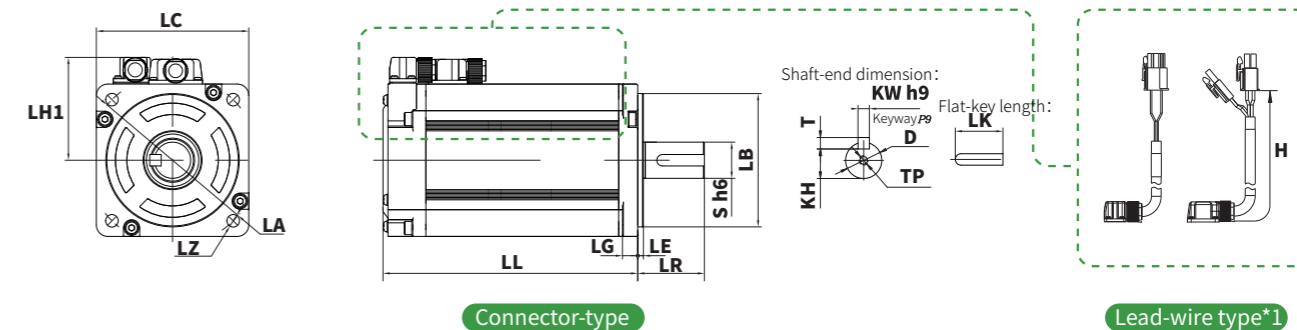

X6MG085A / X6MG100A / X6MG130A / X6MG180A

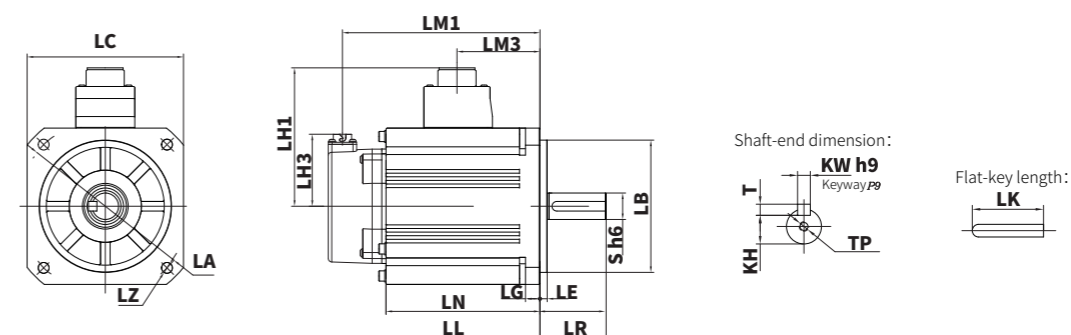

*1: For X6 series servo motors, the lead-wire types are needed to be customized. For details, please contact our sales department.

Servo Motor Specifications 850 W 1.3 KW 1.8 KW

Items	Unit	X6MG085S	X6MG130S	X6MG180S		
Rated power	W	850	1300	1800		
Rated voltage	V	220	220	220		
Fitting flange size	mm	130	130	130		
Rated torque	N.m	5.39	8.28	11.5		
Instantaneous max. torque	N.m	16.2	24.842	34.5		
Rated speed	r/min	1500	1500	1500		
Max. speed	r/min	3000	3000	3000		
Rated current	Arms	6.7	9.6	15.6		
Instantaneous max. current	Arms	20.1	28.8	46.8		
Moment of inertia	No brake	$\times 10^{-4} \text{Kg.m}^2$	13.9	19.9	26	
	With brake	$\times 10^{-4} \text{Kg.m}^2$	16	22	28.1	
Torque constant	N.m/A	0.859	0.891	0.748		
Induced voltage constant per phase	mV[r/min]	31.04	32.08	27		
Rated power rate	No brake	KW/S	20.9	35	50.9	
	With brake	KW/S	18.2	31.6	47.1	
Mechanical time constant	No brake	ms	2.74	2.23	1.95	
	With brake	ms	3.16	2.46	2.29	
Electrical time constant	ms	10.2	10.7	11.14		
Phase q-axis/d-axis inductance	mH	—	—	—		
Weight: No brake[with brake]	kg	5.7 [7.7]	7.3 [9.2]	8.8 [11.2]		
Permissible load	Radial load	N	490	490	490	
	Axial load	N	196	196	196	
Brake specification	Rated voltage	V	DC24V \pm 10%			
	Rated current	A	0.41	0.41	0.41	
	Brake power	w	10	10	10	
	Static friction torque	N.m	14 or more	14 or more	14 or more	
	Note: Holding brake	Suction time	ms	100 or less	100 or less	100 or less
	Release time	ms	80 or less	80 or less	80 or less	
Release voltage	ms	DC1V or more				

Torque characteristics



External Dimensions for Servo Motor

Unit(mm)

Models	X6MG085S	X6MG130S	X6MG180S
LC	130	130	130
LA	$\phi 145$	$\phi 145$	$\phi 145$
LB	$\phi 110$	$\phi 110$	$\phi 110$
LZ	4- $\phi 9$	4- $\phi 9$	4- $\phi 9$
LR	58	58	58
S	$\phi 19 \text{ h6}$	$\phi 22 \text{ h6}$	$\phi 24 \text{ h6}$
LL no brake [with brake]	141.1 [177.1]	157.1 [193.1]	175.1 [211.1]
LN no brake [with brake]	97.5 [133.5]	113.5 [149.5]	131.5 [167.5]
LG	12	12	12
LE	6	6	6
LF	40	40	40
LM1 no brake [with brake]	129.4 [165.4]	145.3 [181.3]	163.3 [193.3]
LM2 no brake [with brake]	— [114.5]	— [130.5]	— [148.5]
LM3	83	99	117
LH1	105	105	105
LH2	79.5	79.5	79.5
LH3	60	60	60
LK	25	25	25
T	5	6	7
KW	5 h9	6 h9	8 h9
KH	16	18.5	20
TP	M5depth16	M5depth16	M5depth16

X6MG085S/X6MG130S/X6MG180S

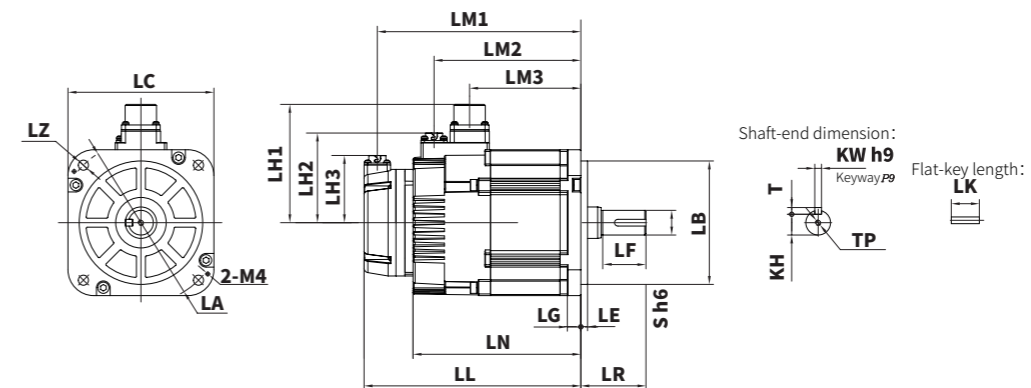

Servo Motor Specifications 1 KW 1.5 KW 2 KW

Items	Unit	X6MM100A*1	X6MM150A*1	X6MM200A*1	
Rated power	W	1000	1500	2000	
Rated voltage	V	380	380	380	
Fitting flange size	mm	130	130	130	
Rated torque	N.m	4.77	7.16	9.55	
Instantaneous max. torque	N.m	14.3	21.5	28.6	
Rated speed	r/min	2000	2000	2000	
Max. speed	r/min	3000	3000	3000	
Rated current	Arms	3	4.3	5.3	
Instantaneous max. current	Arms	9	13	16	
Moment of inertia	No brake	$\times 10^{-4}$ Kg.m ²	6.18	9.16	12.1
	With brake	$\times 10^{-4}$ Kg.m ²	7.4	10.4	13.3
Torque constant	N.m/A	1.56	1.67	1.8	
Induced voltage constant per phase	mV[r/min]	57.2	61.5	66	
Rated power rate	No brake	KW/S	36.9	56	75.4
	With brake	KW/S	30.8	49.3	68.6
Mechanical time constant	No brake	ms	1.72	1.34	1.33
	With brake	ms	2.06	1.52	1.47
Electrical time constant	ms	1.72	12.27	13.9	
Phase q-axis/d-axis inductance	mH	24.1/12.2	18.5/9.45	18/9.3	
Weight: No brake[with brake]	kg	4.69[6.29]	5.8 [7.4]	6.88[8.48]	
Permissible load	Radial load	N	490	490	490
	Axial load	N	196	196	196
Brake specification	Rated voltage	V	DC24V±10%		
	Rated current	A	0.9	0.9	0.9
	Brake power	w	22	22	22
	Static friction torque	N.m	14 or more	14 or more	14 or more
Note: Holding brake	Suction time	ms	100 or less	100 or less	100 or less
	Release time	ms	60 or less	60 or less	60 or less
	Release voltage	ms	DC1V or more		

Torque characteristics

Instantaneous operation range Continuous operation range

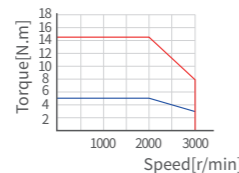

X6MM100A ▲

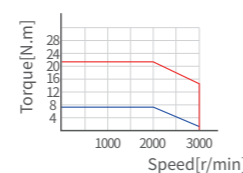

X6MM150A ▲



X6MM200A ▲

External Dimensions for Servo Motor

Unit(mm)

Models	X6MM100A*1	X6MM150A*1	X6MM200A*1
LC	130	130	130
LA	φ145	φ145	φ145
LB	φ110	φ110	φ110
LZ	4-φ9	4-φ9	4-φ9
LR	55	55	55
S	φ22 h6	φ22 h6	φ22 h6
LL (17bit) no brake [with brake]	107.5[127.5]	121.5[141.5]	135.5[155.5]
LL (23bit) no brake [with brake]	128[148]	142 [162]	156[176]
LN no brake [with brake]	80[100]	94[114]	108[128]
LG	12	12	12
LE	6	6	6
LM1 (17bit) no brake [with brake]	95.5[115.5]	109.5[129.5]	123.5[143.5]
LM1 (23bit) no brake [with brake]	116.2[136.2]	130.2[150.2]	144.2[164.2]
LM3 no brake [with brake]	41	55	69
LH1 no brake [with brake]	115	115	115
LH3 (17bit) no brake [with brake]	56.5	56.5	56.5
LH3 (23bit) no brake [with brake]	60	60	60
LK	45	45	45
T	7	7	7
KW	8 h9	8 h9	8 h9
KH	18	18	18
TP	M6depth20	M6depth20	M6depth20

X6MM100A / X6MM150A / X6MM200A

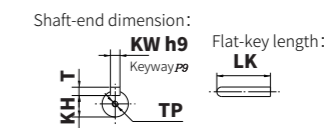
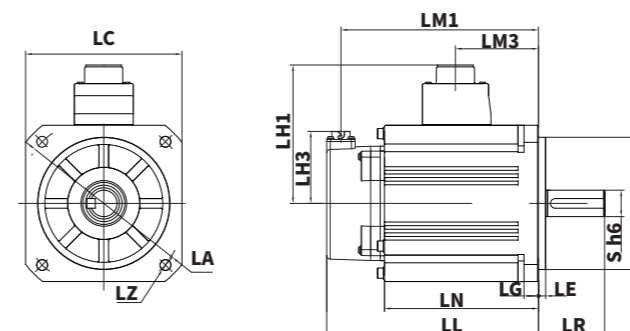

Servo Motor Specifications

3 KW 4 KW 5 KW 7.5 KW

Items	Unit	X6MM300A	X6MM400A	X6MM500A	X6MM750H	
Rated power	W	3000	4000	5000	7500	
Rated voltage	V	380	380	380	380	
Fitting flange size	mm	180	180	180	180	
Rated torque	N.m	14.3	19.1	23.9	47.8	
Instantaneous max. torque	N.m	42.9	57.3	71.6	119.4	
Rated speed	r/min	2000	2000	2000	1500	
Max. speed	r/min	3000	3000	3000	3000	
Rated current	Arms	8.7	11.5	13.5	25.3	
Instantaneous max. current	Arms	30	38	45	65.8	
Moment of inertia	No brake	$\times 10^{-4} \text{Kg.m}^2$	43.5	54.7	66.7	136.4
	With brake	$\times 10^{-4} \text{Kg.m}^2$	63.2	68	80.8	150.8
Torque constant	N.m/A	1.8	1.82	2.04	2.1	
Induced voltage constant per phase	mV[r/min]	62.9	63.5	71.3	74.3	
Rated power rate	No brake	KW/S	47.2	66.7	85.5	167.5
	With brake	KW/S	32.5	53.6	70.5	151.5
Mechanical time constant	No brake	ms	1.4	1.29	1.10	0.96
	With brake	ms	2.03	1.61	1.33	1.06
Electrical time constant	ms	18.7	19	21.7	26.9	
Phase q-axis/d-axis inductance	mH	5.8	4.4	4.5	2.5	
Weight: No brake[with brake]	kg	14.3 [19]	16.5 [21.2]	19.4 [24.1]	28.2[32.9]	
Permissible load	Radial load	N	784	784	784	2058
	Axial load	N	343	343	343	980
Brake specification	Rated voltage	V	DC24V±10%			
	Rated current	A	1.04	1.04	1.04	1.04
	Brake power	w	25	25	25	25
	Static friction torque	N.m	74 or more	74 or more	74 or more	74 or more
	Note: Holding brake	Suction time	ms	120 or less	120 or less	120 or less
	Release time	ms	30 or less	30 or less	30 or less	30 or less
	Release voltage	ms	DC0.5 or more			

External Dimensions for Servo Motor

Unit(mm)

Models	X6MM300A	X6MM400A	X6MM500A	X6MM750H
LC	180	180	180	180
LA	230	230	230	230
LB	$\phi 114.3 \text{ h7}$	$\phi 114.3 \text{ h7}$	$\phi 114.3 \text{ h7}$	$\phi 114.3 \text{ h7}$
LZ	4- $\phi 13.5$	4- $\phi 13.5$	4- $\phi 13.5$	4- $\phi 13.5$
LR	70±0.5	70±0.5	70±0.5	113±0.5
S	$\phi 35 \text{ h6}$	$\phi 35 \text{ h6}$	$\phi 35 \text{ h6}$	$\phi 42 \text{ h6}$
LL (17bit) no brake [with brake]	159±1[211±1]	173±1[225±1]	188±1[240±1]	253±1[305±1]
LL (23bit) no brake [with brake]	172±1[231.5±1]	186±1[245.5±1]	201±1[260.5±1]	266±1[325.5±1]
LN no brake [with brake]	128[182.5]	142[196.5]	157[211.5]	222[276.5]
LG	18	18	18	18
LE	3.2	3.2	3.2	3.2
LM1 (17bit) no brake [with brake]	147[199]	161[213]	176[228]	241[293]
LM1 (23bit) no brake [with brake]	160[220]	174[234]	189[248.7]	254[314]
LM2 no brake [with brake]	107[125.8]	121[139.8]	136[154.8]	201[219.8]
LM3	50	50	50	90
LH1 no brake [with brake]	144[138.6]	144[138.6]	144[138.6]	144[138.6]
LH2	105.3	105.3	105.3	105.3
LH3 (17bit) no brake [with brake]	55[56.4]	55[56.4]	55[56.4]	55[56.4]
LH3 (23bit) no brake [with brake]	60[59.8]	60[59.8]	60[59.8]	60[59.8]
LK	50	50	50	90
T	8	8	8	8
KW	10 h9	10 h9	10 h9	12 h9
KH	30	30	30	37
TP	M12depth25	M12depth25	M12depth25	M16depth32

X6MM300A/X6MM400A/X6MM500A/X6MM750H

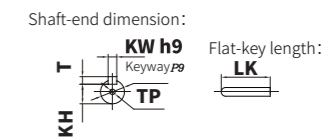
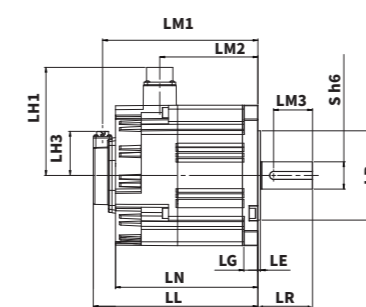
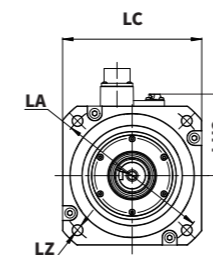

Torque characteristics

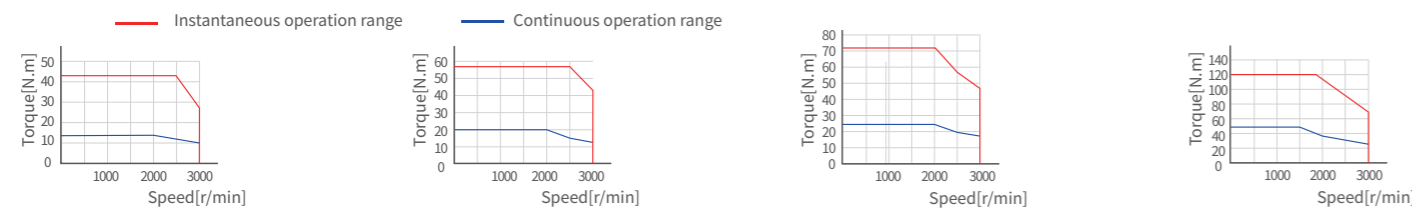

X6MM300A ▲ X6MM400A ▲ X6MM500A ▲ X6MM750H ▲

Servo Motor Specifications 2 KW 4 KW

Items	Unit	X6MH200A	X6MH400A	
Rated power	W	2000	4000	
Rated voltage	V	380	380	
Fitting flange size	mm	180	180	
Rated torque	N.m	9.55	19.1	
Instantaneous max. torque	N.m	28.6	57.3	
Rated speed	r/min	2000	2000	
Max. speed	r/min	3000	3000	
Rated current	Arms	5.8	11.5	
Instantaneous max. current	Arms	19	38	
Moment of inertia	No brake	$\times 10^{-4}$ Kg.m ²	31.4	101.7
	With brake	$\times 10^{-4}$ Kg.m ²	44.6	115
Torque constant	N.m/A	1.83	1.82	
Induced voltage constant per phase	mV[r/min]	63.9	63.5	
Rated power rate	No brake	KW/S	29	35.9
	With brake	KW/S	20.4	31.7
Mechanical time constant	No brake	ms	1.86	2.40
	With brake	ms	2.64	2.71
Electrical time constant	ms	15.2	19	
Phase q-axis/d-axis inductance	mH	9.5	4.5	
Weight: No brake[with brake]	kg	12.7 [17.4]	17.8 [24]	
Permissible load	Radial load	N	784	784
	Axial load	N	343	343
Brake specification	Rated voltage	V	DC24V±10%	
	Rated current	A	1.04	1.04
	Brake power	w	25	25
	Static friction torque	N.m	74 or more	74 or more
Note: Holding brake	Suction time	ms	120 or less	120 or less
	Release time	ms	30 or less	30 or less
	Release voltage	ms	DC0.5V or more	

Torque characteristics

— Instantaneous operation range — Continuous operation range



X6MH200A ▲



X6MH400A ▲

External Dimensions for Servo Motor

Unit(mm)

Models	X6MH200A	X6MH400A
LC	180	180
LA	230	230
LB	φ114.3 h7	φ114.3 h7
LZ	4-φ13.5	4-φ13.5
LR	70±0.5	70±0.5
S	φ35 h6	φ35 h6
LL (17bit) no brake [with brake]	144±1[196±1]	191±1[243±1]
LL (23bit) no brake [with brake]	157±1[216.5±1]	204±1[263.5±1]
LN no brake [with brake]	113[167.5]	160[214.5]
LG	18	18
LE	3.2	3.2
LM1 (17bit) no brake [with brake]	132[184]	179[231]
LM1 (23bit) no brake [with brake]	145[205]	192[252]
LM2 no brake [with brake]	92[110.8]	139[157.8]
LM3	50	50
LH1 no brake [with brake]	144[138.6]	144[138.6]
LH2	105.3	105.3
LH3 (17bit) no brake [with brake]	55[56.4]	55[56.4]
LH3 (23bit) no brake [with brake]	60[59.8]	60[59.8]
LK	50	50
T	8	8
KW	10 h9	10 h9
KH	30	30
TP	M12depth25	M12depth25

▼ X6MH200A / X6MH400A

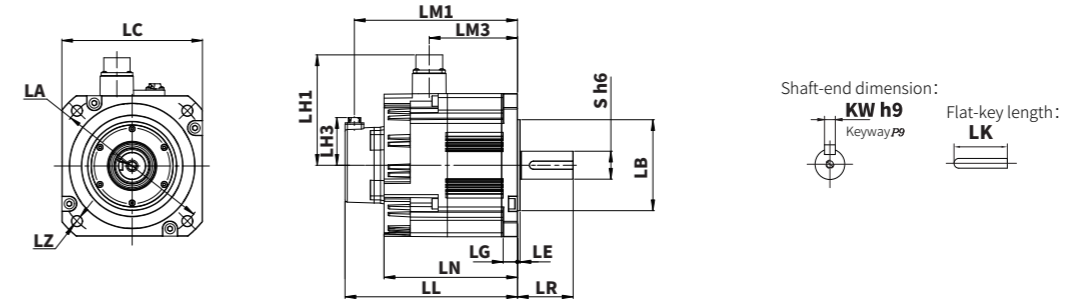

X6MM-Medium inertia

X6MH-High inertia

X6MG-Low speed and high torque

X6MH-High inertia

X6MM-Medium inertia

Servo Motor Specifications 850 W 1.3 KW 1.8 KW

Items	Unit	X6MG085A*1	X6MG130A*1	X6MG180A*1	
Rated power	W	850	1300	1800	
Rated voltage	V	380	380	380	
Fitting flange size	mm	130	130	130	
Rated torque	N.m	5.41	8.27	11.46	
Instantaneous max. torque	N.m	16.2	24.8	34.4	
Rated speed	r/min	1500	1500	1500	
Max. speed	r/min	3000	3000	3000	
Rated current	Arms	4	6	8.5	
Instantaneous max. current	Arms	14	20	29	
Moment of inertia	No brake	$\times 10^{-4}$ Kg.m ²	14	20.2	26
	With brake	$\times 10^{-4}$ Kg.m ²	15.2	21.4	27.2
Torque constant	N.m/A	1.316	1.36	1.335	
Induced voltage constant per phase	mV[r/min]	48.7	50.4	49.4	
Rated power rate	No brake	KW/S	21.1	34.4	50.4
	With brake	KW/S	18.3	31.1	46.9
Mechanical time constant	No brake	ms	3.37	2.9	2.64
	With brake	ms	4.29	3.2	2.84
Electrical time constant	ms	11.7	14	15	
Phase q-axis/d-axis inductance	mH	20.14/10.27	14.2/7.28	10/5.15	
Weight: No brake[with brake]	kg	5.68 [7.28]	6.95[8.55]	8.16 [9.76]	
Permissible load	Radial load	N	490	490	490
	Axial load	N	196	196	196
Brake specification	Rated voltage	V	DC24V±10%		
	Rated current	A	0.9	0.9	0.9
	Brake power	w	21.6	21.6	21.6
	Static friction torque	N.m	14 or more	14 or more	14 or more
Note: Holding brake	Suction time	ms	100 or less	100 or less	100 or less
	Release time	ms	60 or less	60 or less	60 or less
	Release voltage	ms	DC1V or more		

External Dimensions for Servo Motor

Unit(mm)

Models	X6MG085A*1	X6MG130A*1	X6MG180A*1
LC	130	130	130
LA	φ145	φ145	φ145
LB	φ110	φ110	φ110
LZ	4-φ9	4-φ9	4-φ9
LR	55	55	55
S	φ22 h6	φ22 h6	φ22 h6
LL (17bit) no brake [with brake]	135.5 [155.5]	149.5 [169.5]	163.5 [183.5]
LL (23bit) no brake [with brake]	156 [176]	170 [190]	184 [204]
LN no brake [with brake]	108 [128]	122 [142]	136 [156]
LG	12	12	12
LE	6	6	6
LM1 (17bit) no brake [with brake]	123.5 [143.5]	137.5 [157.5]	151.5 [171.5]
LM1 (23bit) no brake [with brake]	144.2 [164.2]	158.2 [178.2]	172.2 [192.2]
LM3	69	83	97
LH1	115	115	115
LH3 (17bit)	56.5	56.5	56.5
LH3 (23bit)	60	60	60
LK	45	45	45
T	7	7	7
KW	8 h9	8 h9	8 h9
KH	18	18	18
TP	M6depth20	M6depth20	M6depth20

X6MG085A / X6MG130A / X6MG180A

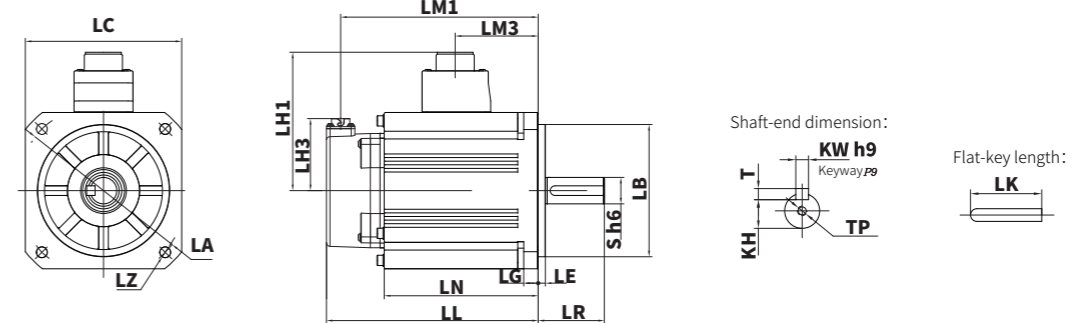

Torque characteristics

Instantaneous operation range (red line) Continuous operation range (blue line)

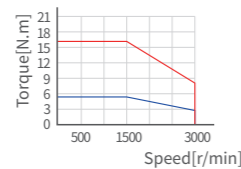

X6MG085A ▲



X6MG130A ▲

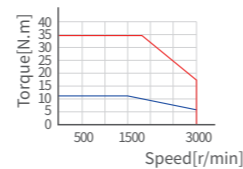

X6MG180A ▲

Servo Motor Specifications

2.4 KW 2.9 KW 4.4 KW 5.5 KW

Items	Unit	X6MG240A*1	X6MG290A	X6MG440A	X6MG550A	
Rated power	W	2400	2900	4400	5500	
Rated voltage	V	380	380	380	380	
Fitting flange size	mm	130	180	180	180	
Rated torque	N.m	15.2	18.6	28.4	35	
Instantaneous max. torque	N.m	45.7	46.5	71.1	87.5	
Rated speed	r/min	1500	1500	1500	1500	
Max. speed	r/min	3000	3000	3000	3000	
Rated current	Arms	10	10	15.7	19.5	
Instantaneous max. current	Arms	30	26	41	51	
Moment of inertia	No brake	$\times 10^{-4} \text{Kg.m}^2$	31.3	47.2	68.6	91.4
	With brake	$\times 10^{-4} \text{Kg.m}^2$	32.5	62.3	83.7	106.5
Torque constant	N.m/A	1.52	2.01	2.13	1.98	
Induced voltage constant per phase	mV[r/min]	57.6	70.2	74.2	69.6	
Rated power rate	No brake	KW/S	123	73.3	114.4	134.2
	With brake	KW/S	116	55.5	93.8	115.1
Mechanical time constant	No brake	ms	0.669	1.35	1.18	1.07
	With brake	ms	0.712	1.79	1.44	1.25
Electrical time constant	ms	20	19.2	19.9	22.9	
Phase q-axis/d-axis inductance	mH	6.2/3.1	6.7	4.7	3.2	
Weight: No brake[with brake]	kg	14.1[15.7]	16[20.7]	19.4 [24.1]	23.9[28.5]	
Permissible load	Radial load	N	490	1470	1470	1764
	Axial load	N	196	490	490	588
Brake specification	Rated voltage	V	DC24V \pm 10%			
	Rated current	A	0.9	1.04	1.04	1.04
	Brake power	w	22	25	25	25
	Static friction torque	N.m	15.2 or more	74 or more	74 or more	74 or more
Note: Holding brake	Suction time	ms	100 or less	120 or less	120 or less	120 or less
	Release time	ms	60 or less	30 or less	30 or less	30 or less
	Release voltage	ms	DC0.5 or more			

Torque characteristics

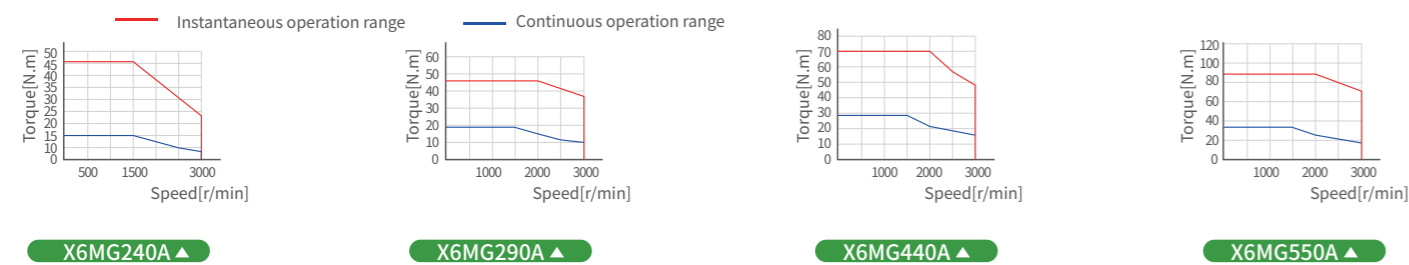

External Dimensions for Servo Motor

Unit(mm)

Models	X6MG240A*1	X6MG290A	X6MG440A	X6MG550A
LC	130	180	180	180
LA	$\phi 145$	230	230	230
LB	$\phi 110 \text{ h7}$	$\phi 114.3 \text{ h7}$	$\phi 114.3 \text{ h7}$	$\phi 114.3 \text{ h7}$
LZ	4- $\phi 9$	4- $\phi 13.5$	4- $\phi 13.5$	4- $\phi 13.5$
LR	65	79 \pm 0.5	79 \pm 0.5	113 \pm 0.5
S	$\phi 24 \text{ h6}$	$\phi 35^{+0.01}_0$	$\phi 35^{+0.01}_0$	$\phi 42^{+0.01}_0$
LL (17bit) no brake [with brake]	231.5 \pm 1[251.5 \pm 1]	165 \pm 1[217 \pm 1]	191 \pm 1[243 \pm 1]	220 \pm 1[272 \pm 1]
LL (23bit) no brake [with brake]	—	178 \pm 1[237.5 \pm 1]	204 \pm 1[263.5 \pm 1]	233 \pm 1[292.5 \pm 1]
LN no brake [with brake]	204[224]	134[188.5]	160[214.5]	189[243.5]
LG	12	18	18	18
LE	6	3.2	3.2	3.2
LM1 (17bit) no brake [with brake]	219.5[239.5]	153[205]	179[231]	208[260]
LM1 (23bit) no brake [with brake]	—	166[226]	192[252]	221[281]
LM2 no brake [with brake]	165[165]	113[131.8]	139[157.8]	168[186.8]
LM3	—	60	60	90
LH1 no brake [with brake]	115	144[138.6]	144[138.6]	144[138.6]
LH2	—	105.3	105.3	105.3
LH3 (Magnetic encoder) no brake [with brake]	56.5	55[56.4]	55[56.4]	55[56.4]
LH3 (Optical encoder) no brake [with brake]	—	60[59.8]	60[59.8]	60[59.8]
LK	51	60	60	90
T	7	8	8	8
KW	8 h9	10 h9	10 h9	12 h9
KH	20	30	30	37
TP	M6depth20	M12depth25	M12depth25	M16depth32

X6MG240A

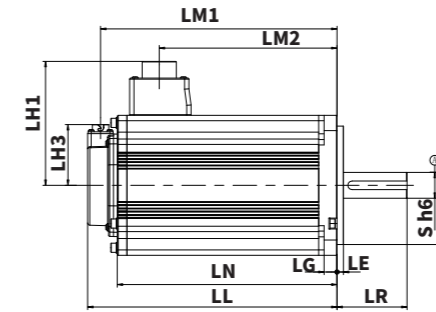
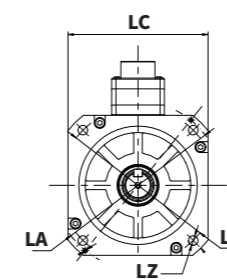

Shaft-end dimension:

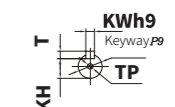

Flat-key length:



X6MG290A / X6MG440A / X6MG550A

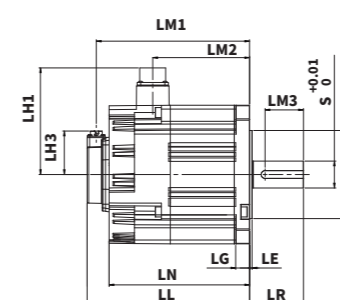
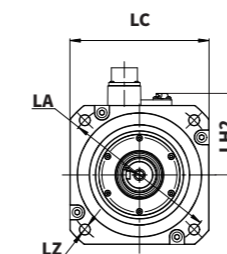

Shaft-end dimension:

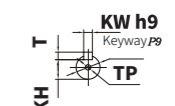

Flat-key length:



Servo Motor Specifications 2.9 KW 4.4 KW

Items	Unit	X6MG290S	X6MG440S
Rated power	W	2900	4400
Rated voltage	V	380	380
Fitting flange size	mm	180	180
Rated torque	N.m	18.6	28.4
Instantaneous max. torque	N.m	55.8	71.1
Rated speed	r/min	1500	1500
Max. speed	r/min	4000	4000
Rated current	Arms	13.5	20.3
Instantaneous max. current	Arms	44.5	53
Moment of inertia	No brake	$47.2 \times 10^{-4} \text{Kg.m}^2$	68.6
	With brake	$62.3 \times 10^{-4} \text{Kg.m}^2$	83.7
Torque constant	N.m/A	1.51	1.6
Induced voltage constant per phase	mV[r/min]	52.5	56
Rated power rate	No brake	73.3	114.4
	With brake	55.5	93.8
Mechanical time constant	No brake	1.37	1.15
	With brake	1.81	1.4
Electrical time constant	ms	18.5	18.3
Phase q-axis/d-axis inductance	mH	3.7	2.4
Weight: No brake[with brake]	kg	16 [20.7]	19.4 [24.1]
Permissible load	Radial load	1470	1470
	Axial load	490	490
Brake specification	Rated voltage	DC24V±10%	
	Rated current	1.04	1.04
	Brake power	25	25
	Static friction torque	74 or more	74 or more
Note: Holding brake	Suction time	120 or less	120 or less
	Release time	30 or less	30 or less
	Release voltage	DC0.5V or more	

Torque characteristics

— Instantaneous operation range — Continuous operation range

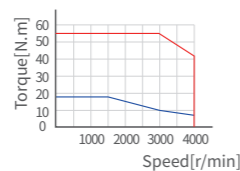

X6MG290S ▲



X6MG440S ▲

External Dimensions for Servo Motor

Unit(mm)

Models	X6MG290S	X6MG440S
LC	180	180
LA	230	230
LB	$\phi 114.3 \text{ h7}$	$\phi 114.3 \text{ h7}$
LZ	4- $\phi 13.5$	4- $\phi 13.5$
LR	79±0.5	79±0.5
S	$\phi 35^{+0.01}_0$	$\phi 35^{+0.01}_0$
LL (17bit) no brake [with brake]	165±1[217±1]	191±1[243±1]
LL (23bit) no brake [with brake]	178±1[237.5±1]	204±1[263.5±1]
LN no brake [with brake]	134[188.5]	160[214.5]
LG	18	18
LE	3.2	3.2
LM1 (17bit) no brake [with brake]	153[205]	179[231]
LM1 (23bit) no brake [with brake]	166[226]	192[252]
LM2 no brake [with brake]	113[131.8]	139[157.8]
LM3	60	60
LH1 no brake [with brake]	144[138.6]	144[138.6]
LH2	105.3	105.3
LH3 (17bit) no brake [with brake]	55[56.4]	55[56.4]
LH3 (23bit) no brake [with brake]	60[59.8]	60[59.8]
LK	60	60
T	8	8
KW	10 h9	10 h9
KH	30	30
TP	M12depth25	M12depth25

▼ X6MG290S / X6MG440S

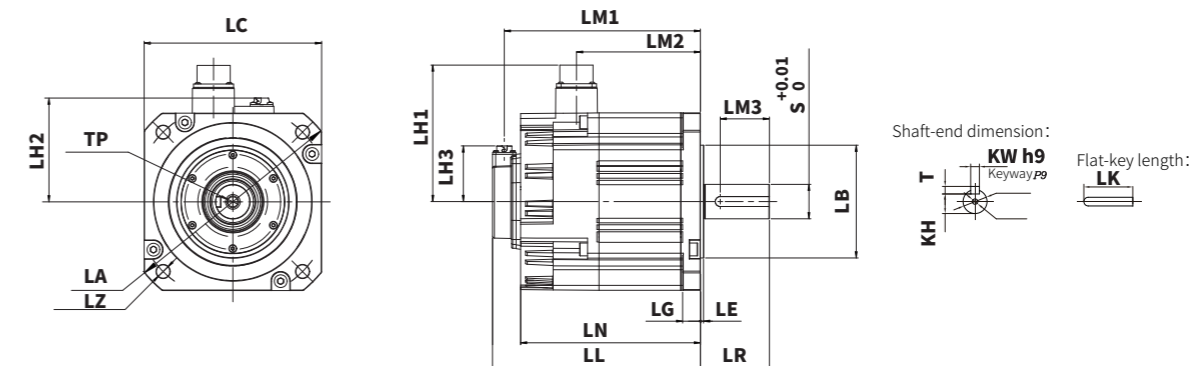

	Power	Models	23bit absolute	17bit absolute	Brake	Oil seal	Flange	Shaft diameter	Regular model	Applicable accessories		Power	Standard:X6E [] _ _ _ A-A / full-fuction:X6F [] _ _ _ A-A				X5E [] _ _ _ A-A				Notes	
													[A]Pulse control	[N] CANopen	[B] EtherCAT	[R] PROFINET	Power specifications	[A]Pulse control	[N] CANopen	[B] EtherCAT		Power specifications
X6-MA Low inertia series	200W	X6MA020A-N2CD	●		●	●	60 flange	Φ14	Connector-type	① ⑤ ③① ① ⑥ ③①		200W	X6EA020A-A	X6EN020A-A	X6EB020A-A	X6ER020A-A	Single-phase AC220V	X5EA040A-A	X5EN040A-A	X5EB040A-A	Single-phase AC220V	Futures
		X6FA020A-A											X6FN020A-A	X6FB020A-A	X6FR020A-A	X5EA040A-A		X5EN040A-A	X5EB040A-A			
	400W	X6MA040A-N2CD	●		●	●	60 flange	Φ14	Connector-type	① ⑤ ③① ① ⑥ ③①		400W	X6EA040A-A	X6EN040A-A	X6EB040A-A	X6ER040A-A	Single-phase AC220V	X5EA040A-A	X5EN040A-A	X5EB040A-A	Single-phase AC220V	Futures
		X6FA040A-A											X6FN040A-A	X6FB040A-A	X6FR040A-A	X5EA040A-A		X5EN040A-A	X5EB040A-A			
	750W	X6MA075A-N2CD	●		●	●	80 flange	Φ19	Connector-type	① ⑤ ③① ① ⑥ ③①		750W	X6EA075A-A	X6EN075A-A	X6EB075A-A	X6ER075A-A	Single-phase AC220V	X5EA075A-A	X5EN075A-A	X5EB075A-A	Single-phase AC220V	Futures
		X6FA075A-A											X6FN075A-A	X6FB075A-A	X6FR075A-A	X5EA075A-A		X5EN075A-A	X5EB075A-A			
	1KW	X6MA100A-N2LD	●		●	●	100 flange	Φ19	Aviation connector	⑪ ⑫ ③① ⑪ ⑫ ⑭ ③①		1KW	X6EA100A-A	X6EN100A-A	X6EB100A-A	X6ER100A-A	Three-phase AC220V	X5EA100A-A	X5EN100A-A	X5EB100A-A	Single-phase AC220V	
		X6FA100A-A											X6FN100A-A	X6FB100A-A	X6FR100A-A	X5EA100A-A		X5EN100A-A	X5EB100A-A			
	1.5KW	X6MA150A-N2LD	●		●	●	100 flange	Φ19	Aviation connector	⑪ ⑫ ③① ⑪ ⑫ ⑭ ③①		1.5KW	X6EA150A-A	X6EN150A-A	X6EB150A-A	X6ER150A-A	Three-phase AC220V	X5EA150A-A	X5EN150A-A	X5EB150A-A	Three-phase AC220V	
		X6FA150A-A											X6FN150A-A	X6FB150A-A	X6FR150A-A	X5EA150A-A		X5EN150A-A	X5EB150A-A			
	2KW	X6MA200A-N2LD	●		●	●	100 flange	Φ19	Aviation connector	⑪ ⑫ ③① ⑪ ⑫ ⑭ ③①		2KW	X6EA200A-A	X6EN200A-A	X6EB200A-A	X6ER200A-A	Three-phase AC220V	X5EA200A-A	X5EN200A-A	X5EB200A-A	Three-phase AC220V	
		X6FA200A-A											X6FN200A-A	X6FB200A-A	X6FR200A-A	X5EA200A-A		X5EN200A-A	X5EB200A-A			
X6-MM Middle inertia series	1KW	X6MM100A-N2LD	●		●	●	130 flange	Φ22	Aviation connector	⑪ ⑫ ③① ⑪ ⑬ ③①		1KW	X6EA100A-A	X6EN100A-A	X6EB100A-A	X6ER100A-A	Three-phase AC220V	X5EA100A-A	X5EN100A-A	X5EB100A-A	Three-phase AC220V	
		X6FA100A-A											X6FN100A-A	X6FB100A-A	X6FR100A-A	X5EA100A-A		X5EN100A-A	X5EB100A-A			
	1.5KW	X6MM150A-N2LD	●		●	●	130 flange	Φ22	Aviation connector	⑪ ⑫ ③① ⑪ ⑬ ③①		1.5KW	X6EA150A-A	X6EN150A-A	X6EB150A-A	X6ER150A-A	Three-phase AC220V	X5EA150A-A	X5EN150A-A	X5EB150A-A	Three-phase AC220V	
		X6FA150A-A											X6FN150A-A	X6FB150A-A	X6FR150A-A	X5EA150A-A		X5EN150A-A	X5EB150A-A			
2KW	X6MM200A-N2LD	●		●	●	130 flange	Φ22	Aviation connector	⑪ ⑫ ③① ⑪ ⑬ ③①		2KW	X6EA200A-A	X6EN200A-A	X6EB200A-A	X6ER200A-A	Three-phase AC220V	X5EA200A-A	X5EN200A-A	X5EB200A-A	Three-phase AC220V		
	X6FA200A-A											X6FN200A-A	X6FB200A-A	X6FR200A-A	X5EA200A-A		X5EN200A-A	X5EB200A-A				
X6-MH High inertia Series	50W	X6MH005A-N2CD	●		●	●	40 flange	Φ8	Connector-type	① ③ ③① ① ④ ③①		50W	X6EA010A-A	X6EN010A-A	X6EB010A-A	X6ER010A-A	Single-phase AC220V	X5EA040A-A	X5EN040A-A	X5EB040A-A	Single-phase AC220V	
		X6FA010A-A											X6FN010A-A	X6FB010A-A	X6FR010A-A	X5EA040A-A		X5EN040A-A	X5EB040A-A			
	100W	X6MH010A-N2CD	●		●	●	40 flange	Φ8	Connector-type	① ③ ③① ① ④ ③①		100W	X6EA010A-A	X6EN010A-A	X6EB010A-A	X6ER010A-A	Single-phase AC220V	X5EA040A-A	X5EN040A-A	X5EB040A-A	Single-phase AC220V	
		X6FA010A-A											X6FN010A-A	X6FB010A-A	X6FR010A-A	X5EA040A-A		X5EN040A-A	X5EB040A-A			
	150W	X6MH015A-N2CD	●		●	●	40 flange	Φ8	Connector-type	① ③ ③① ① ④ ③①		150W	X6EA020A-A	X6EN020A-A	X6EB020A-A	X6ER020A-A	Single-phase AC220V	X5EA040A-A	X5EN040A-A	X5EB040A-A	Single-phase AC220V	
		X6FA020A-A											X6FN020A-A	X6FB020A-A	X6FR020A-A	X5EA040A-A		X5EN040A-A	X5EB040A-A			
	200W	X6MH020A-N2CD	●		●	●	60 flange	Φ14	Connector-type	① ⑤ ③① ① ⑥ ③①		200W	X6EA020A-A	X6EN020A-A	X6EB020A-A	X6ER020A-A	Single-phase AC220V	X5EA040A-A	X5EN040A-A	X5EB040A-A	Single-phase AC220V	
		X6FA020A-A											X6FN020A-A	X6FB020A-A	X6FR020A-A	X5EA040A-A		X5EN040A-A	X5EB040A-A			
	400W	X6MH040A-N2CD	●		●	●	60 flange	Φ14	Connector-type	① ⑤ ③① ① ⑥ ③①		400W	X6EA040A-A	X6EN040A-A	X6EB040A-A	X6ER040A-A	Single-phase AC220V	X5EA040A-A	X5EN040A-A	X5EB040A-A	Single-phase AC220V	
		X6FA040A-A											X6FN040A-A	X6FB040A-A	X6FR040A-A	X5EA040A-A		X5EN040A-A	X5EB040A-A			
	750W	X6MH075A-N2CD	●		●	●	80 flange	Φ19	Connector-type	① ⑤ ③① ① ⑥ ③①		750W	X6EA075A-A	X6EN075A-A	X6EB075A-A	X6ER075A-A	Single-phase AC220V	X5EA075A-A	X5EN075A-A	X5EB075A-A	Single-phase AC220V	
		X6FA075A-A											X6FN075A-A	X6FB075A-A	X6FR075A-A	X5EA075A-A		X5EN075A-A	X5EB075A-A			
	1KW	X6MH100A-N2LD	●		●	●	130 flange	Φ22	Aviation connector	⑪ ⑫ ③① ⑪ ⑬ ③①		1KW	X6EA100A-A	X6EN100A-A	X6EB100A-A	X6ER100A-A	Three-phase AC220V	X5EA100A-A	X5EN100A-A	X5EB100A-A	Single-phase AC220V	
		X6FA100A-A											X6FN100A-A	X6FB100A-A	X6FR100A-A	X5EA100A-A		X5EN100A-A	X5EB100A-A			
	1.5KW	X6MH150A-N2LD	●		●	●	130 flange	Φ22	Aviation connector	⑪ ⑫ ③① ⑪ ⑬ ③①		1.5KW	X6EA150A-A	X6EN150A-A	X6EB150A-A	X6ER150A-A	Three-phase AC220V	X5EA150A-A	X5EN150A-A	X5EB150A-A	Three-phase AC220V	
		X6FA150A-A											X6FN150A-A	X6FB150A-A	X6FR150A-A	X5EA150A-A		X5EN150A-A	X5EB150A-A			

Accessories specifications for connector-type servo motors if flange 40 to 80

- ① SVCAB-ENC075CA-ABS-***L-05 Absolute encoder cable
- ② SVCAB-ENC075CA-***L-05 Incremental encoder cable
- ③ SVCAB-PWR010CA-***L-05 UVW power cable 50W~100W
- ④ SVCAB-PWB010CA-***L-05 UVWpower cable with brake 50W~100W
- ⑤ SVCAB-PWR075CA-***L-05 UVWpower cable 200W~1KW
- ⑥ SVCAB-PWB075CA-***L-05 UVWpower cable with brake 200W~1KW

Aviation connector specifications for servo motor of flange 100&130&180

- ⑪ ENC-TE 1KW Encoder accessories (10-pin aviation connector + 1394 connector)
- ⑫ PWR-CON 1KW 4-core power aviation connector, for flange 100&130
- ⑬ PWR-CON 1KW-9P 9-pin brake power aviation connector, for flange 100&130
- ⑭ PWB-CON- 1KW 2-core brake power connector *1
- ⑮ PWR-CON 7.5KW 4-core power aviation connector, for flange 180
- ⑯ For flange 130 models, only X2MA100A/150A/200A/X2MG230A and 180 flange models require PWB-CON- 1KW

Accessories specifications for lead-wire type servo motor of flange 40 to 80

- ⑰ ENC-TE 750W 2 packs of encoder accessories (6-hole plastic connector + 1394 connector)
- ⑱ PWR-CON 750W 4-hole power plastic connector
- ⑲ PWB-CON 750W 6-hole power brake plastic connector

Other accessories specifications

- ⑳ SV-BAT Absolute battery box with 1394 connector
- 

	Power	Models	23bit absolute	17bit absolute	Brake	Oil seal	Flange	Shaft diameter	Regular model	Applicable accessories		Power	Standard:X6E [] _ _ _ A-A / full-fuction:X6F [] _ _ _ A-A				X5E [] _ _ _ A-A				Notes
													[A]Pulse control	[N] CANopen	[B] EtherCAT	[R] PROFINET	Power specifications	[A]Pulse control	[N] CANopen	[B] EtherCAT	
X6-MHH Ultrahigh inertia	100W	X6MH010H-N2CD	●		●	●	40 flange	Φ8	Connector-type	① ③ ③① ① ④ ③①		100W	X6EA010A-A	X6EN010A-A	X6EB010A-A	X6ER010A-A	Single-phase AC220V	X5EA040A-A	X5EN040A-A	X5EB040A-A	Single-phase AC220V
		X6FA010A-A											X6FN010A-A	X6FB010A-A	X6FR010A-A						
	200W	X6MH020H-N2LD	●		●	●	60 flange	Φ14	Lead-wire type	②① ②② ③① ②① ②② ②③ ③①		200W	X6EA020A-A	X6EN020A-A	X6EB020A-A	X6ER020A-A	Single-phase AC220V	X5EA040A-A	X5EN040A-A	X5EB040A-A	Single-phase AC220V
		X6FA020A-A											X6FN020A-A	X6FB020A-A	X6FR020A-A						
	400W	X6MH040H-N2CD	●		●	●	60 flange	Φ14	Connector-type	① ⑤ ③① ① ⑥ ③①		400W	X6EA040A-A	X6EN040A-A	X6EB040A-A	X6ER040A-A	Single-phase AC220V	X5EA040A-A	X5EN040A-A	X5EB040A-A	Single-phase AC220V
X6FA040A-A		X6FN040A-A											X6FB040A-A	X6FR040A-A							
750W	X6MH075H-N2LD	●		●	●	80 flange	Φ19	Lead-wire type	②① ②② ③①		750W	X6EA075A-A	X6EN075A-A	X6EB075A-A	X6ER075A-A	Single-phase AC220V	X5EA075A-A	X5EN075A-A	X5EB075A-A	Single-phase AC220V	
X6-MQ Special flange/Flat-type /small flange	100W	X6MQ010A-N2LD	●		●	●	60 flange	Φ8	Lead-wire type	②① ②② ③① ②① ②② ②③ ③①		100W	X6EA010A-A	X6EN010A-A	X6EB010A-A	X6ER010A-A	Single-phase AC220V	X5EA040A-A	X5EN040A-A	X5EB040A-A	Single-phase AC220V
		X6MQ010A-B2LD																			
	200W	X6MQ020A-N2LD	●		●	●	80 flange	Φ11	Lead-wire type	②① ②② ③① ②① ②② ②③ ③①		200W	X6EA020A-A	X6EN020A-A	X6EB020A-A	X6ER020A-A	Single-phase AC220V	X5EA040A-A	X5EN040A-A	X5EB040A-A	Single-phase AC220V
		X6MQ020A-B2LD																			
	400W	X6MQ040A-N2LD	●		●	●	80 flange	Φ14	Lead-wire type	②① ②② ③① ②① ②② ②③ ③①		400W	X6EA040A-A	X6EN040A-A	X6EB040A-A	X6ER040A-A	Single-phase AC220V	X5EA040A-A	X5EN040A-A	X5EB040A-A	Single-phase AC220V
		X6MQ040A-B2LD																			
1KW	X6MQ100E-N2CD	●		●	●	80 flange	Φ19	Connector-type	① ⑤ ③① ① ⑥ ③①		1KW	X6EA100A-A	X6EN100A-A	X6EB100A-A	X6ER100A-A	Three-phase AC220V	X5EA100A-A	X5EN100A-A	X5EB100A-A	Single-phase AC220V	
	X6MQ100E-B2CD																				
X6-MG Low-speed and Large-torque	750W	X6MG075A-N2LD	●		●	●	80 flange	Φ19	Lead-wire type	②① ②② ③① ②① ②② ②③ ③①		750W	X6EA075A-A	X6EN075A-A	X6EB075A-A	X6ER075A-A	Three-phase AC220V	X5EA075A-A	X5EN075A-A	X5EB075A-A	Three-phase AC220V
		X6MG075A-B2LD																			
	1KW	X6MG100A-N2LD	●		●	●	130 flange	Φ22	Aviation connector	①① ①② ③① ①① ①③ ③①		1KW	X6EA100A-A	X6EN100A-A	X6EB100A-A	X6ER100A-A	Three-phase AC220V	X5EA100A-A	X5EN100A-A	X5EB100A-A	Three-phase AC220V
		X6MG100A-B2LD																			
	850W	X6MG085A-N2LD	●		●	●	130 flange	Φ22	Aviation connector	①① ①② ③① ①① ①③ ③①		850W	X6EA100A-A	X6EN100A-A	X6EB100A-A	X6ER100A-A	Three-phase AC220V	X5EA100A-A	X5EN100A-A	X5EB100A-A	Single-phase AC220V
		X6MG085A-B2LD																			
	1.3KW	X6MG130A-N2LD	●		●	●	130 flange	Φ22	Aviation connector	①① ①② ③① ①① ①③ ③①		1.3KW	X6EA150A-A	X6EN150A-A	X6EB150A-A	X6ER150A-A	Three-phase AC220V	X5EA150A-A	X5EN150A-A	X5EB150A-A	Three-phase AC220V
		X6MG130A-B2LD																			
1.8KW	X6MG180A-N2LD	●		●	●	130 flange	Φ22	Aviation connector	①① ①② ③① ①① ①③ ③①		1.8KW	X6EA250A-A	X6EN250A-A	X6EB250A-A	X6ER250A-A	Three-phase AC220V	X5EA250A-A	X5EN250A-A	X5EB250A-A	Three-phase AC220V	
	X6MG180A-B2LD																				
X6-MGS Low-cogging Cutting	850W	X6MG085S-N2LD	●		●	●	130 flange	Φ19	Aviation connector	①① ①② ③① ①① ①③ ③①		850W	X6EA150A-A	X6EN150A-A	X6EB150A-A	X6ER150A-A	Three-phase AC220V	X5EA150A-A	X5EN150A-A	X5EB150A-A	Three-phase AC220V
		X6MG085S-B2LD																			
	1.3KW	X6MG130S-N2LD	●		●	●	130 flange	Φ22	Aviation connector	①① ①② ③① ①① ①③ ③①		1.3KW	X6EA150A-A	X6EN150A-A	X6EB150A-A	X6ER150A-A	Three-phase AC220V	X5EA150A-A	X5EN150A-A	X5EB150A-A	Three-phase AC220V
		X6MG130S-B2LD																			
1.8KW	X6MG180S-N2LD	●		●	●	130 flange	Φ24	Aviation connector	①① ①② ③① ①① ①③ ③①		1.8KW	X6EA250A-A	X6EN250A-A	X6EB250A-A	X6ER250A-A	Three-phase AC220V	X5EA250A-A	X5EN250A-A	X5EB250A-A	Three-phase AC220V	
	X6MG180S-B2LD																				

Accessories specifications for connector-type servo motors if flange 40 to 80

- ① SVCAB-ENC075CA-ABS-***L-05 Absolute encoder cable
- ② SVCAB-ENC075CA-***L-05 Incremental encoder cable
- ③ SVCAB-PWR010CA-***L-05 UVW power cable 50W~100W
- ④ SVCAB-PWB010CA-***L-05 UVWpower cable with brake 50W~100W
- ⑤ SVCAB-PWR075CA-***L-05 UVWpower cable 200W~1KW
- ⑥ SVCAB-PWB075CA-***L-05 UVWpower cable with brake 200W~1KW

Aviation connector specifications for servo motor of flange 100&130&180

- ⑪ ENC-TE 1KW Encoder accessories (10-pin aviation connector + 1394 connector)
- ⑫ PWR-CON 1KW 4-core power aviation connector, for flange 100&130
- ⑬ PWR-CON 1KW-9P 9-pin brake power aviation connector, for flange 100&130
- ⑭ PWB-CON- 1KW 2-core brake power connector *1
- ⑮ PWR-CON 7.5KW 4-core power aviation connector, for flange 180
- ⑯ For flange 130 models, only X2MA100A/150A/200A/X2MG230A and 180 flange models require PWB-CON- 1KW

Accessories specifications for lead-wire type servo motor of flange 40 to 80

- ⑰ ENC-TE 750W 2 packs of encoder accessories (6-hole plastic connector + 1394 connector)
- ⑱ PWR-CON 750W 4-hole power plastic connector
- ⑳ PWB-CON 750W 6-hole power brake plastic connector

Other accessories specifications

- ⑳ SV-BAT Absolute battery box with 1394 connector
- 

	Power	Models	23bit absolute	17bit absolute	Brake	Oil seal	Flange	Shaft diameter	Regular model	Applicable accessories		Power	Standard:X6E [] _ _ _ A-A / full-fuction:X6F [] _ _ _ A-A					Notes
													[A]Pulse control	[N] CANopen	[B] EtherCAT	[R] PROFINET	Power specifications	
X6-MM Middle Inertia	1KW	X6MM100A-N4LD	●		●	●	130 flange	Φ22	Aviation connector	11 12 31		1KW	X6EA200T-A X6FA200T-A	X6EN200T-A X6FN200T-A	X6EB200T-A X6FB200T-A	X6ER200T-A X6FR200T-A	Three-phase AC380V	
		X6MM100A-B4LD			●	●				11 13 31								
		X6MM100A-N4LA		●		●				11 12								
		X6MM100A-B4LA			●	●				11 13								
	1.5KW	X6MM150A-N4LD	●		●	●	130 flange	Φ22	Aviation connector	11 12 31		1.5KW	X6EA200T-A X6FA200T-A	X6EN200T-A X6FN200T-A	X6EB200T-A X6FB200T-A	X6ER200T-A X6FR200T-A	Three-phase AC380V	
		X6MM150A-B4LD			●	●				11 13 31								
		X6MM150A-N4LA		●		●				11 12								
		X6MM150A-B4LA			●	●				11 13								
	2KW	X6MM200A-N4LD	●		●	●	130 flange	Φ22	Aviation connector	11 12 31		2KW	X6EA200T-A X6FA200T-A	X6EN200T-A X6FN200T-A	X6EB200T-A X6FB200T-A	X6ER200T-A X6FR200T-A	Three-phase AC380V	
		X6MM200A-B4LD			●	●				11 13 31								
		X6MM200A-N4LA		●		●				11 12								
		X6MM200A-B4LA			●	●				11 13								
	3KW	X6MM300A-N4LD	●		●	●	180 flange	Φ35	Aviation connector	11 15 31		3KW	X6EA300T-A X6FA300T-A	X6EN300T-A X6FN300T-A	X6EB300T-A X6FB300T-A	X6ER300T-A X6FR300T-A	Three-phase AC380V	
		X6MM300A-B4LD			●	●				11 15 14 31								
		X6MM300A-N4LA		●		●				11 15								
		X6MM300A-B4LA			●	●				11 15 14								
	4KW	X6MM400A-N4LD	●		●	●	180 flange	Φ35	Aviation connector	11 15 31		4KW	X6EA500T-A X6FA500T-A	X6EN500T-A X6FN500T-A	X6EB500T-A X6FB500T-A	X6ER500T-A X6FR500T-A	Three-phase AC380V	
		X6MM400A-B4LD			●	●				11 15 14 31								
		X6MM400A-N4LA		●		●				11 15								
		X6MM400A-B4LA			●	●				11 15 14								
	5KW	X6MM500A-N4LD	●		●	●	180 flange	Φ35	Aviation connector	11 15 31		5KW	X6EA750T-A X6FA750T-A	X6EN750T-A X6FN750T-A	X6EB750T-A X6FB750T-A	X6ER750T-A X6FR750T-A	Three-phase AC380V	
		X6MM500A-B4LD			●	●				11 15 14 31								
		X6MM500A-N4LA		●		●				11 15								
		X6MM500A-B4LA			●	●				11 15 14								
7.5KW	X6MM750H-N4LD	●		●	●	180 flange	Φ42	Aviation connector	11 15 31		7.5KW	X6EA750T-A X6FA750T-A	X6EN750T-A X6FN750T-A	X6EB750T-A X6FB750T-A	X6ER750T-A X6FR750T-A	Three-phase AC380V		
	X6MM750H-B4LD			●	●				11 15 14 31									
	X6MM750H-N4LA		●		●				11 15									
	X6MM750H-B4LA			●	●				11 15 14									
X6-MH High Inertia	2KW	X6MH200A-N4LD	●		●	●	180 flange	Φ35	Aviation connector	11 15 31		2KW	X6EA200T-A X6FA200T-A	X6EN200T-A X6FN200T-A	X6EB200T-A X6FB200T-A	X6ER200T-A X6FR200T-A	Three-phase AC380V	
		X6MH200A-B4LD			●	●				11 15 14 31								
		X6MH200A-N4LA		●		●				11 15								
		X6MH200A-B4LA			●	●				11 15 14								
	4KW	X6MH400A-N4LD	●		●	●	180 flange	Φ35	Aviation connector	11 15 31		4KW	X6EA500T-A X6FA500T-A	X6EN500T-A X6FN500T-A	X6EB500T-A X6FB500T-A	X6ER500T-A X6FR500T-A	Three-phase AC380V	
		X6MH400A-B4LD			●	●				11 15 14 31								
		X6MH400A-N4LA		●		●				11 15								
		X6MH400A-B4LA			●	●				11 15 14								

Accessories specifications for connector-type servo motors if flange 40 to 80

- 1 SVCAB-ENC075CA-ABS-***L-05 Absolute encoder cable
- 2 SVCAB-ENC075CA-***L-05 Incremental encoder cable
- 3 SVCAB-PWR010CA-***L-05 UVW power cable 50W~100W
- 4 SVCAB-PWB010CA-***L-05 UVWpower cable with brake 50W~100W
- 5 SVCAB-PWR075CA-***L-05 UVWpower cable 200W~1KW
- 6 SVCAB-PWB075CA-***L-05 UVWpower cable with brake 200W~1KW

Aviation connector specifications for servo motor of flange 100&130&180

- 11 ENC-TE 1KW Encoder accessories (10-pin aviation connector + 1394 connector)
- 12 PWR-CON 1KW 4-core power aviation connector, for flange 100&130
- 13 PWR-CON 1KW-9P 9-pin brake power aviation connector, for flange 100&130
- 14 PWB-CON- 1KW 2-core brake power connector *1
- 15 PWR-CON 7.5KW 4-core power aviation connector, for flange 180
- 31 For flange 130 models, only X2MA100A/150A/200A/X2MG230A and 180 flange models require PWB-CON- 1KW

Accessories specifications for lead-wire type servo motor of flange 40 to 80

- 21 ENC-TE 750W 2 packs of encoder accessories (6-hole plastic connector + 1394 connector)
- 22 PWR-CON 750W 4-hole power plastic connector
- 23 PWB-CON 750W 6-hole power brake plastic connector

Other accessories specifications

- 31 SV-BAT Absolute battery box with 1394 connector
- 

	Power	Models	23bit absolute	17bit absolute	Brake	Oil seal	Flange	Shaft diameter	Regular model	Applicable accessories		Power	Standard:X6E [] _ _ _ A-A / full-fuction:X6F [] _ _ _ A-A					Notes	
													[A]Pulse control	[N] CANopen	[B] EtherCAT	[R] PROFINET	Power specifications		
X6-MG Low-speed and Large-torque	850W	X6MG085A-N4LD	●			●	130 flange	Φ22	Aviation connector	11 12 31		850W	X6EA200T-A X6FA200T-A	X6EN200T-A X6FN200T-A	X6EB200T-A X6FB200T-A	X6ER200T-A X6FR200T-A	Three-phase AC380V		
		X6MG085A-B4LD			●	●				11 13 31									
		X6MG085A-N4LA				●	●				11 12								
		X6MG085A-B4LA		●		●	●				11 13								
	1.3KW	X6MG130A-N4LD	●			●	●	130 flange	Φ22	Aviation connector	11 12 31		1.3KW	X6EA200T-A X6FA200T-A	X6EN200T-A X6FN200T-A	X6EB200T-A X6FB200T-A	X6ER200T-A X6FR200T-A	Three-phase AC380V	
		X6MG130A-B4LD			●	●	●				11 13 31								
		X6MG130A-N4LA				●	●				11 12								
		X6MG130A-B4LA		●		●	●				11 13								
	1.8KW	X6MG180A-N4LD	●			●	●	130 flange	Φ22	Aviation connector	11 12 31		1.8KW	X6EA300T-A X6FA300T-A	X6EN300T-A X6FN300T-A	X6EB300T-A X6FB300T-A	X6ER300T-A X6FR300T-A	Three-phase AC380V	
		X6MG180A-B4LD			●	●	●				11 13 31								
		X6MG180A-N4LA				●	●				11 12								
		X6MG180A-B4LA		●		●	●				11 13								
	2.4KW	X6MG240A-N4LD	●			●	●	130 flange	Φ22	Aviation connector	11 12 31		2.4KW	X6EA500T-A X6FA500T-A	X6EN500T-A X6FN500T-A	X6EB500T-A X6FB500T-A	X6ER500T-A X6FR500T-A	Three-phase AC380V	
		X6MG240A-B4LD			●	●	●				11 13 31								
		X6MG240A-N4LA				●	●				11 12								
		X6MG240A-B4LA		●		●	●				11 13								
	2.9KW	X6MG290A-N4LD	●			●	●	180 flange	Φ35	Aviation connector	11 15 31		2.9KW	X6EA300T-A X6FA300T-A	X6EN300T-A X6FN300T-A	X6EB300T-A X6FB300T-A	X6ER300T-A X6FR300T-A	Three-phase AC380V	
		X6MG290A-B4LD			●	●	●				11 15 14 31								
		X6MG290A-N4LA				●	●				11 15								
		X6MG290A-B4LA		●		●	●				11 15 14								
	4.4KW	X6MG440A-N4LD	●			●	●	180 flange	Φ35	Aviation connector	11 15 31		4.4KW	X6EA500T-A X6FA500T-A	X6EN500T-A X6FN500T-A	X6EB500T-A X6FB500T-A	X6ER500T-A X6FR500T-A	Three-phase AC380V	
X6MG440A-B4LD				●	●	●				11 15 14 31									
X6MG440A-N4LA					●	●				11 15									
X6MG440A-B4LA			●		●	●				11 15 14									
5.5KW	X6MG550A-N4LD	●			●	●	180 flange	Φ42	Aviation connector	11 15 31		5.5KW	X6EA750T-A X6FA750T-A	X6EN750T-A X6FN750T-A	X6EB750T-A X6FB750T-A	X6ER750T-A X6FR750T-A	Three-phase AC380V		
	X6MG550A-B4LD			●	●	●				11 15 14 31									
	X6MG550A-N4LA				●	●				11 15									
	X6MG550A-B4LA		●		●	●				11 15 14									
X6-MGS Low-cogging Cutting	2.9KW	X6MG290S-N4LD	●			●	180 flange	Φ35	Aviation connector	11 15 31		2.9KW	X6EA750T-A X6FA750T-A	X6EN750T-A X6FN750T-A	X6EB750T-A X6FB750T-A	X6ER750T-A X6FR750T-A	Three-phase AC380V		
		X6MG290S-B4LD			●	●	●				11 15 14 31								
		X6MG290S-N4LA				●	●				11 15								
		X6MG290S-B4LA		●		●	●				11 15 14								
4.4KW	X6MG440S-N4LD	●			●	●	180 flange	Φ35	Aviation connector	11 15 31		4.4KW	X6EA750T-A X6FA750T-A	X6EN750T-A X6FN750T-A	X6EB750T-A X6FB750T-A	X6ER750T-A X6FR750T-A	Three-phase AC380V		
	X6MG440S-B4LD			●	●	●				11 15 14 31									
	X6MG440S-N4LA				●	●				11 15									
	X6MG440S-B4LA		●		●	●				11 15 14									

Accessories specifications for connector-type servo motors if flange 40 to 80

- 1 SVCAB-ENC075CA-ABS-***L-05 Absolute encoder cable
- 2 SVCAB-ENC075CA-***L-05 Incremental encoder cable
- 3 SVCAB-PWR010CA-***L-05 UVW power cable 50W~100W
- 4 SVCAB-PWB010CA-***L-05 UVWpower cable with brake 50W~100W
- 5 SVCAB-PWR075CA-***L-05 UVWpower cable 200W~1KW
- 6 SVCAB-PWB075CA-***L-05 UVWpower cable with brake 200W~1KW

Aviation connector specifications for servo motor of flange 100&130&180

- 11 ENC-TE 1KW Encoder accessories (10-pin aviation connector + 1394 connector)
- 12 PWR-CON 1KW 4-core power aviation connector, for flange 100&130
- 13 PWR-CON 1KW-9P 9-pin brake power aviation connector, for flange 100&130
- 14 PWB-CON- 1KW 2-core brake power connector *1
- 15 PWR-CON 7.5KW 4-core power aviation connector, for flange 180
- 31 For flange 130 models, only X2MA100A/150A/200A/X2MG230A and 180 flange models require PWB-CON- 1KW

Accessories specifications for lead-wire type servo motor of flange 40 to 80

- 21 ENC-TE 750W 2 packs of encoder accessories (6-hole plastic connector + 1394 connector)
- 22 PWR-CON 750W 4-hole power plastic connector
- 23 PWB-CON 750W 6-hole power brake plastic connector

Other accessories specifications

- 31 SV-BAT Absolute battery box with 1394 connector



SVCAB-ENC 075 C A – ABS-010L-05

1 2 3 4 5 6 7

1 Product type	
ENC	Encoder cable
PWR	4-core power cable
PWB	6-core power cable with brake

5 Encoder type	
ABS	Absolute
N/A	Incremental

2 Motor power	
010	50W~150W
075	200W~1KW

6 Length specifications (unit 0.1m)	
L	Length identification *1

3 Connector-type	
C	Flange 40 to 80

7 Cable flexibility	
01	Fixed
05 (regular)	5 million times
10	10 million times
20	20 million times
A0	For swinging

4 Outlet direction	
A	Forward-The leading direction at the front end
B	Reverse-The leading direction at the back end



*The regular length specifications in our stock is 0.5M/1M/2M/3M/5M/8M/10M.



IP67
Waterproof / dustproof

Power cable
For connector-type servo motor

Encoder cable

Flexible cables EMC Superior quality

Advantages

- The motor cables connected directly to the servo drive, reducing the connection and greatly improving the reliability.
- The protection level of the motor connector upgraded to IP67, vibration-resistance, dustproof and waterproof.
- Encoder cables are treated with metal shielding layer, which has strong anti-interference ability!
- Various specifications of cables can be customized based on the different application occasions. HCFA designated high-quality raw material suppliers for centralized procurement. (See Naming rule 7 for cables)

From the 2nd quarter of 2021, our company started releasing connector-type servo motor with 40-80 flanges as the regular model. Lead-wire servo motors will be discontinued from December 2021, if still needed, the customized application process is required. For details, refer to page 67 or consult our sales staff.

Accessories Specifications for Connector-type Servo Motor

Cables	Model name	Diagram
Absolute encoder cable	SVCAB-ENC075CA-ABS-***L-05	
Incremental encoder cable	SVCAB-ENC075CA-***L-05	
50W~150W UVV power cable	SVCAB-PWR010CA-***L-05	
50W~150W UVV power cable with brake	SVCAB-PWB010CA-***L-05	
200W~1000W UVV power cable	SVCAB-PWR075CA-***L-05	
200W~1000W UVV power cable with brake	SVCAB-PWB075CA-***L-05	

Aviation connectors for servo motor of flange 100&130&180

Accessories	Model name	Diagram
Encoder accessories (10-pin aviation connector + 1394 connector)	ENC-TE 1KW	1
4-core power aviation connector, for flange 100&130	PWR-CON 1KW	2
9-pin brake power aviation connector, for flange 100&130	PWR-CON 1KW-9P	3
2-core brake power connector *1	PWB-CON- 1KW	4
4-core power aviation connector,for flange 180	PWR-CON 7.5KW	5

Accessories	Model name	Diagram
Adapter cable with 1394 connector Absolute battery box	SVBOX-ENCABS	6A

*Flange 130 are only required for X2MA100A/150A/200A/X2MG230A

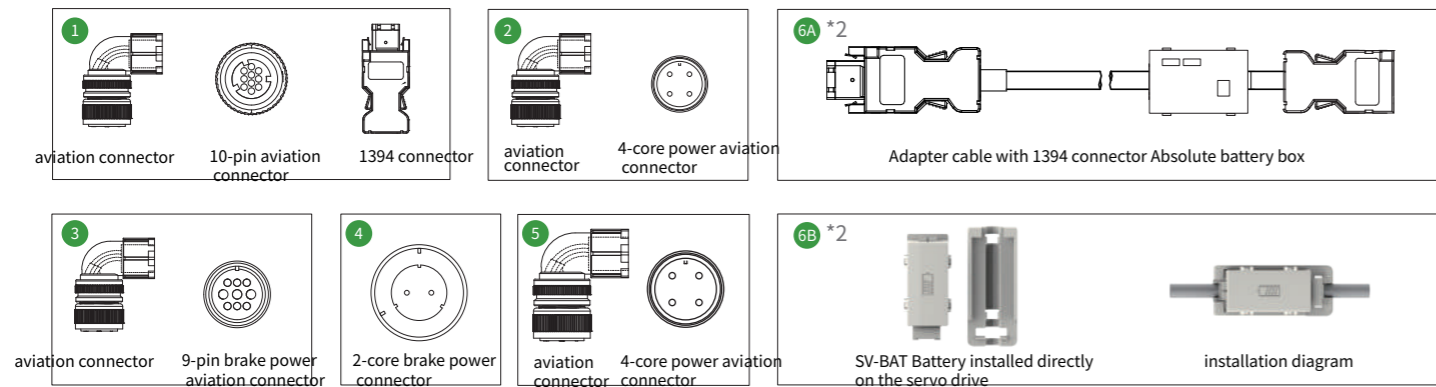

Other accessory specifications

Accessories	Model name	Applicable servo drive	Description
Battery installed directly on the servo drive 6B	SV-BAT	SV-X6 All series SV-X5E All series	Encoder cable external battery, installed on the side of the servo drive
Multifunctional absolute battery panel	SV-ENC-BAT	SV-X6 All series SV-X5E All series	Encoder cable external battery
CAN bus connection cable	SV-CAB-0.3M	SV-X6EN type full power SV-X6FN type full power	CANopen bus-type CN4, CN5 interface
CAN terminal resistance	SV-TR-120	SV-X6EN type full power SV-X6FN type full power	CANopen bus-type CN4, CN5 interface
EtherCAT/profinet bus cable	SV-ECAT-0.35M	SV-X6EB type full power SV-X6ER type full power SV-X6FB type full power SV-X6FR type full power	X6 EtherCAT and profinet bus-type CN4, CN5 interface
		SV-X5EB type full power	X5E EtherCAT bus-type CN4, CN5 interface
RS485cable 0.2m	SV-RS485-0.2M	SV-X6FA full power SV-X6FB full power SV-X6FN full power SV-X6FR full power	All-function models CN1 For 485 communication and analogue AO output port
STO cable 2m	SV-STO-2M	SV-X6FA full power SV-X6FB full power SV-X6FN full power SV-X6FR full power	X6all-function models CN2 interface STO External safety switch
		SV-X5E 1KW or less STO models	X5E models CN2 interface STO External safety switch
Second Encoder cable 2m	SV-MIII-2M	SV-X6FA full power SV-X6FB full power	All-function models CN8 interfaec
Gantry synchronisation signal Cable 0.4m	SV-GS-0.4M	SV-X6FA full power	Gantry synchronisation models CN8 interface
750W or less brake resistors	SV-BRAKE-75A	SV-X6 All series, models of 750W or less SV-X5E All series, models of 750W or less	X6series brake resistor P, BR interface X5Eseries brake resistor P, BR interface
1KW~1.5KW brake resistors	SV-BRAKE-100A	SV-X6 All series models of 1KW to 1.5KW SV-X5E All series models of 1KW to 1.5KW	X6series brake resistor P, BR interface X5Eseries brake resistor P, BR interface
2KW~2.5KW brake resistors	SV-BRAKE-200A	SV-X6 All series 220V series, models of 2KW to 2.5KW SV-X5E All series, models of 2KW to 2.5KW	X6series brake resistor P, BR interface X5Eseries brake resistor P, BR interface
Anti-interference magnetic ring	Magnetic ring	All series	Installed on the power cable and encoder cable, with anti-interference

Other accessory specifications

Waterproof connector/compact accessories	Specifications
ENC-TE 750W-F	6-core waterproof encoder connector + 1394 connector encoder accessory pack
PWR-CON 750W-F	4-core waterproof power connector, for flange 40 to 80
PWB-CON 750W-F	6-core waterproof power connector with brake, for flange 40 to 80
PWR-CON 1KW-F	6-core waterproof power connector, for flange 130

For servo motor of flange 40 to 80

Accessories	Model name	Diagram
2 packs of encoder accessories ((6-hole plastic connector + 1394 connector)	ENC-TE 1KW	7
4-hole power connector accessories	PWR-CON 750W	8
6-hole power brake connector accessories	PWB-CON 750W	9

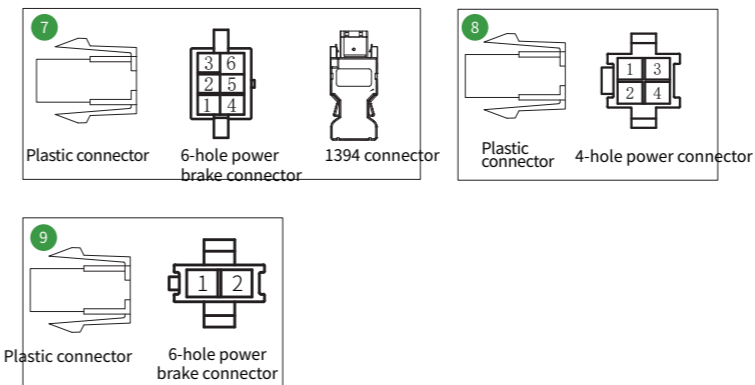

Cable for Lead-wire Type Servo Motor(customized products)

Encoder cable	Specifications
SVCAB-ENC75A-3M	Absolute encoder cable, for lead-wire type servo motor flange 40 to 80, 3 meters
CAB-ENC100A-3M	Incremental encoder cable, for lead-wire type servo motor flange 100&130&180, 3 meters
CAB-ENC100A-ABS-3M	Absolute encoder cable with battery box, for lead-wire type servo motor flange 100&130&180, 3 meters
Power cable	Specifications
CAB-PWR75A-3M	4-core power cable, for lead-wire type servo motor flange 40 to 80, 3 meters
CAB-PWR100A-3M	4-core power cable, for lead-wire type servo motor flange 100&130, 3 meters
CAB-PWR400C-3M	4-core power cable, for lead-wire type servo motor of 2KW to 5KW, flange 180, 3 meters
CAB-PWR750C-5M	CAB-PWR750C-5M 4-core power cable, for lead-wire type servo motor of 5.5KW to 7.5KW, flange 180, 5 meters
Power brake cable	Specifications
CAB-PWB75A-3M	9-core power cable, for lead-wire type servo motor flange 130, 3 meters
CAB-PWB100A-3M	6-core power brake cable, for lead-wire type servo motor flange 40 to 80, 3 meters
CAB-PWD100A-3M	2-core power cable, for lead-wire type servo motor flange 100&130, 3 meters
Waterproof-connector cable	Specifications
SVCAB-ENC75A-3M-F	6-core waterproof absolute encoder cable, for lead-wire type servo motor flange 40 to 130, 3 meters
CAB-PWR75A-3M-F	4-core waterproof power cable, for lead-wire type servo motor flange 40 to 80, 3 meters
CAB-PWB75A-3M-F	6-core waterproof power brake cable, for lead-wire type servo motor flange 40 to 80, 3 meters
CAB-PWB100A-3M-F	9-core waterproof power brake cable, for lead-wire type servo motor flange 130, 3 meters

HCFA Q-Series Standard PACs

Focus on 9 major industries of industrial automation and create overall solutions!



Standard IEC61131-3 specification 6 programming languages

Based on standard PLC OPEN standard motion control
- Linear/circular/spiral interpolation / electronic cam / flying shear / rotary shear



HCFA Y7-Series High-end Servo Products

The new-generation Y7-series advanced servo system adopts the brand-new control algorithm platform to meet the diverse control needs of customers in different industries with excellent driving performance, rich buses and extended functions. At the same time, it's equipped with 7 core performances such as higher dynamic response, accurate positioning and reliability, faster speed and easy-to-use, which comprehensively helps customers in industrial upgrading and enhances the efficiency of machine tools.

Let's cooperate to redefine the performance of your equipment

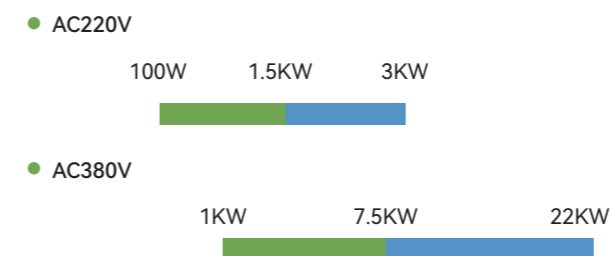

2021-09-02
Officially released on
2021-09-02, welcome to consult!

