

☎ 400-012-6969

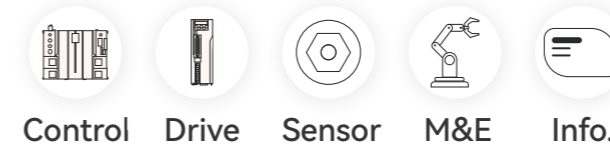

| X3E

SERIES GENERAL-PURPOSE
AC SERVO SYSTEM

| X2E

SERIES SIMPLE-TYPE
AC SERVO SYSTEM

Zhejiang Hechuan Technology Co., Ltd.

www.hcfa.com.cn

Headquarter

No. 9, Fucui Road, Longyou Industrial Zone, Quzhou City, Zhejiang Province, PRC

Hangzhou R&D center

Floor 4, Block D, Quzhou Haichuang Park, No. 1001, Wenyi West Road, Hangzhou City, Zhejiang Province

EtherCAT® is owned by Beckhoff Automation Co., Ltd.; MECHATROLINK® is owned by the MECHATROLINK Association, which is an open field network; The other products, product names, and product trademarks or registered trademarks described in this manual are owned by each company.



HCFA



ATC

All information in this document is subject to change without notice.
Manual No.: October, 2021 Issue No. 8

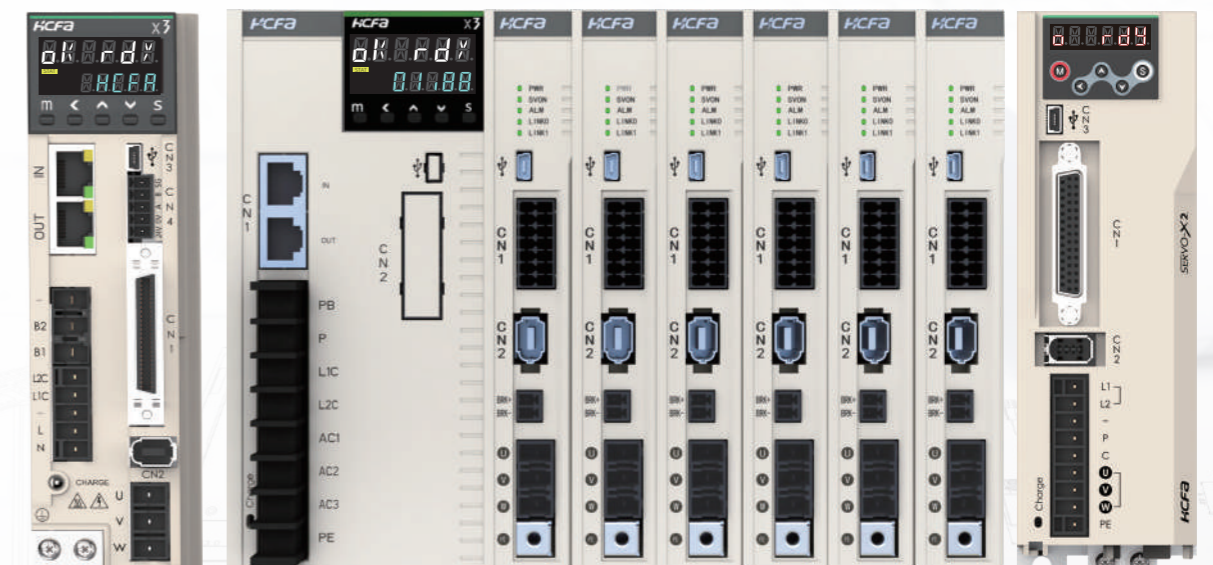

To be the most valuable industrial automation core components and solutions provider

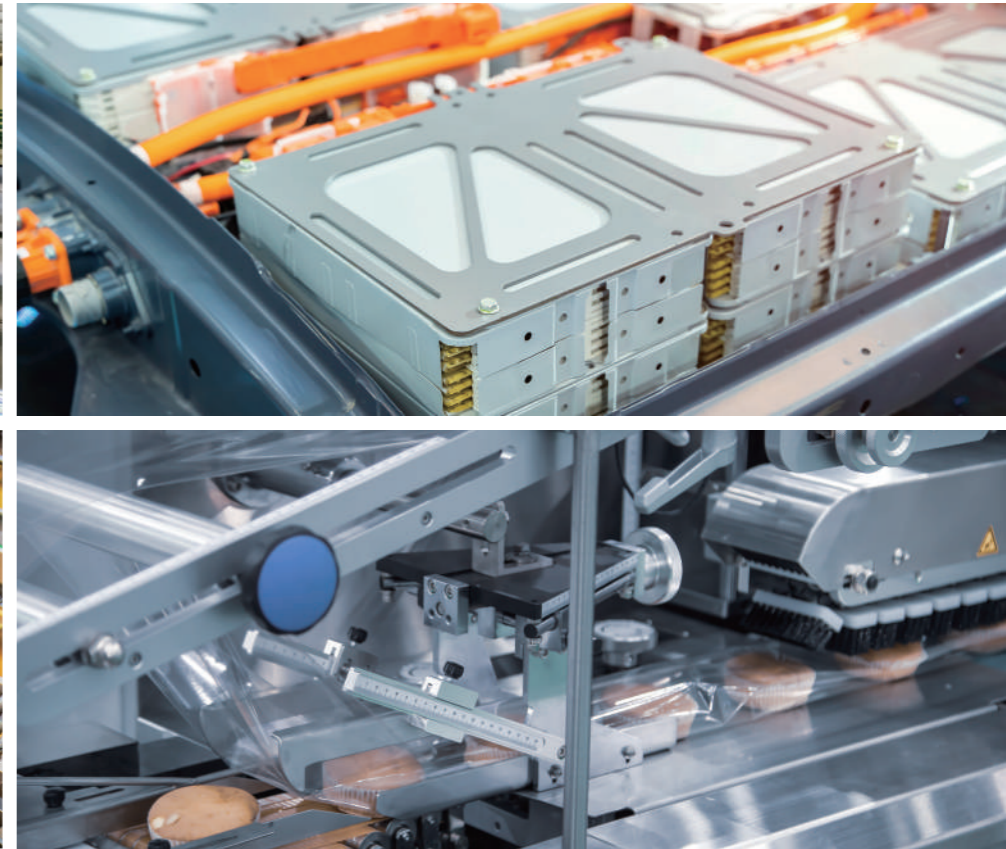
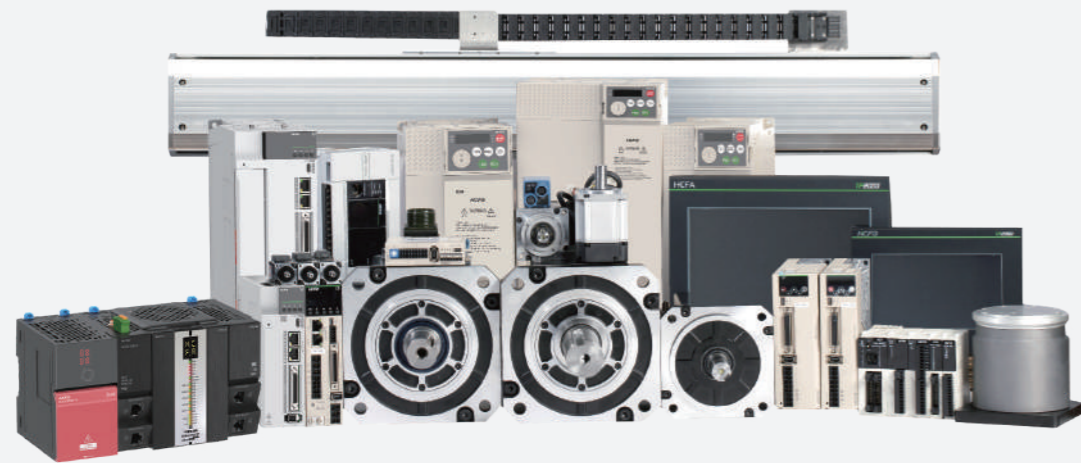

R&D Centers

4

Set up nationally

Sales Offices

40+

Sales elites gathering

Global Distributors

400+

Products sold worldwide

The products are widely used in OEM fields such as photovoltaic, 3C, lithium batteries, robots, packaging, textiles, logistics, lasers, machine tool, etc.



X3E Series General-purpose Servo Drive

Naming Rule

SV-X3E B - 075 - A - A 2 - 00 000

1 2 3 4 5 6 7 8

Product type	
A	Standard type
B	EtherCAT bus- type
N	CANOpen bus-type

4 Control power	
A	AC power

Power specifications	
005	50W
010	100W
020	200W
040	400W
075	750W
100	1KW
150	1.5KW
200	2KW
250	2.5KW

5 Product iteration serial number	
2	N/A

6 Hardware type	
00	N/A
AO	Analog output
PG	PG extension

7 Software customized mark	
000	N/A

Voltage specifications	
A	AC220V

8 Non-standard models (hardware identification + software identification)	
PG000	Full-closed loop
PG005	Gantry synchronization

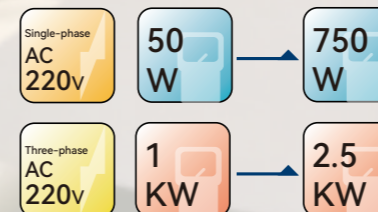

LCD display | **Compact design**

Compact design | **Rich bus-type** | **EtherCAT Technology Group**

General Specifications

Items	Specifications								
Models	005	010	020	040	075	100	150	200	250
Power (W)	50	100	200	400	750	1000	1500	2000	2500
Rated current (Arms)	0.9	1.2	2	3	4.5	6	10	12.5	15.6
Continuous running current (Arms)	0.9	1.2	2	3	4.5	6	10	12.5	15.6
Max. output current (Arms)	2.7	3.6	6	9	13.5	18	30	37.5	37.5
power specifications	Single-phase220V 50~60Hz				Three-phase220V 50~60Hz				
Control power	Single-phase220V								
Applicable encoder	17bit/23bit								
Control mode	Six control mode: Position control, speed control, torque control, position/speed control, position/torque control, speed/torque control								

Environment Specifications

Items	Specifications	
Temperature	Ambient temperature for use	0~55°C
	Ambient temperature for storage	-20~65°C
Humidity	Ambient humidity for use	20~85%RH or less(Without condensation)
	Ambient humidity for storage	20~85%RH or less(Without condensation)
Atmosphere for use& storage	Indoors(Not subject to direct sunlight); free from corrosive gas, flammable gas, oil mist, or dust	
Altitude	1000m or less above sea level	
Vibration	5.8m/s ² (0.6G) or less, 10~60Hz(No continuous operation allowed at frequency of resonance)	
Dielectric strength	1 minute at 1500 VAC across the primary and FG	

Technical Specifications

Items		Specifications		
Position control	Pulse input	Max input pulse frequency	Open-collector pulse input: Up to 200KHz, pulse width larger than 2.5us General input: Up to 500KHz, pulse width larger than 1 us High-speed input: Up to 4MHz, pulse width larger than 125ns	
		Input pulse form	Pulse+ direction, A-Phase + B-Phase, CW+CCW	
		Electronic gear setting	Electronic gear : A/B (Encoder resolution/10000000 < A/B <Encoder resolution/2.5)	
	Pulse output	Smoothing	Smoothing filter, FIR filter	
		Output pulse	Encoder position or pulse synchronization output	
		Division ratio	Arbitrary frequency division	
Output pulse form		Differential output: A/B/ Z, Open collector output: Z-phase		
Internal position mode		Segment 1-16 internal position planning		
Speed control	Control method		External analog command control/0~16 segments speed selection can be realized by DI terminal combination./Communication setting	
	Analog input voltage range		DC±10V(Maximum speed at 10V)	
	Torque limit function		Internal parameter setting or analog input	
Torque control	Control method		External analog instruction control/internal parameter/DI terminal switch(analog/internal parameter)/communication setting	
	Analog input voltage range		DC±10V(Rated torque at 10V)	
	Speed limit		Internal parameter setting or analog input	
Common functions	Control signal	I/O	9IN/9OUT	
	Analog signal	I/O	2IN (±10v)	
	Speed monitoring	Provided		
	Vibration control	Provided		
	Adaptive notch filter	Provided		
	Auto-tuning	Provided		
	Encoder output division and multiplication	Provided		
	Dynamic brake	Can be connected externally		
	Regeneration function	A larger power braking resistor can be connected		
	Protective functions		Overvoltage, power supply error, overcurrent, overheat, overload, encoder error, over speed, position deviation too large, parameter error	
Communication	USB	For PC communication (「Servostudio」connection)		
	Type	RS485	B:EtherCAT	N:CANOPEN

Main power supply AC220V

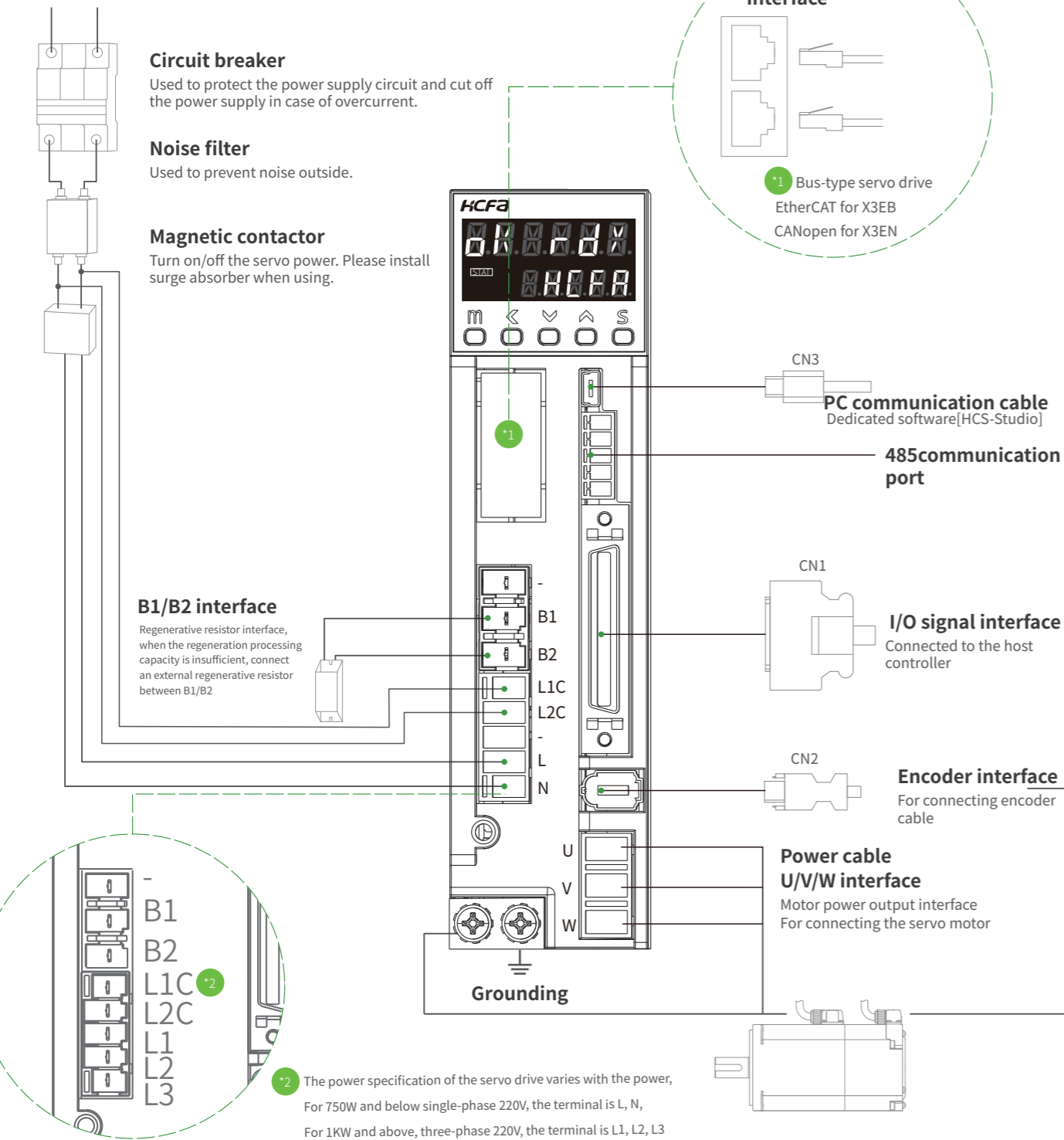

For models of 200W or less Unit:mm

Weight (KG)
0.82

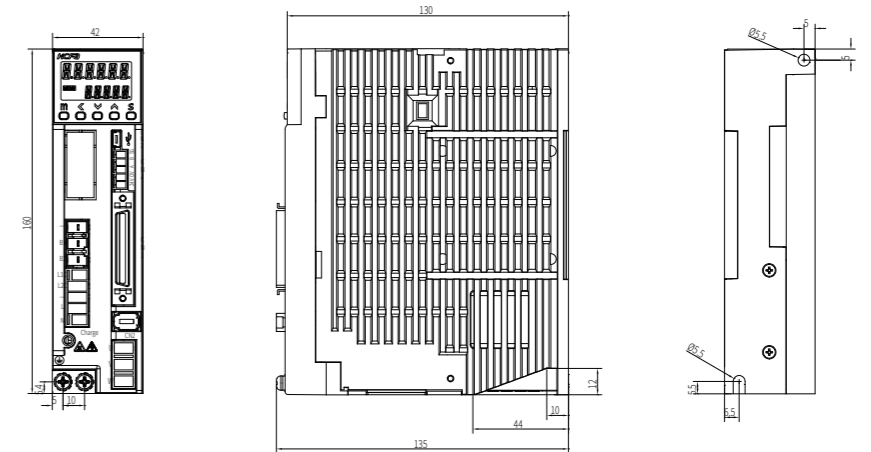

For models of 400W/750W Unit:mm

Weight (KG)
0.86

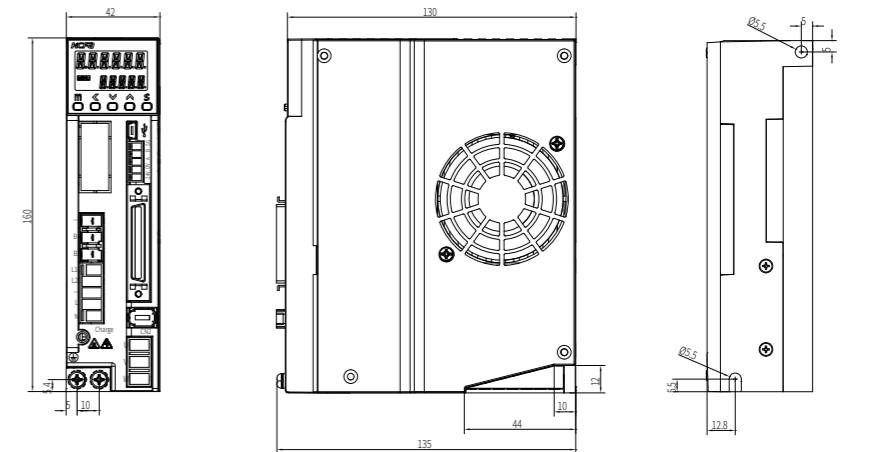

For models of 1KW/1.5KW/2KW/2.5KW Unit:mm

Weight (KG)
1.34

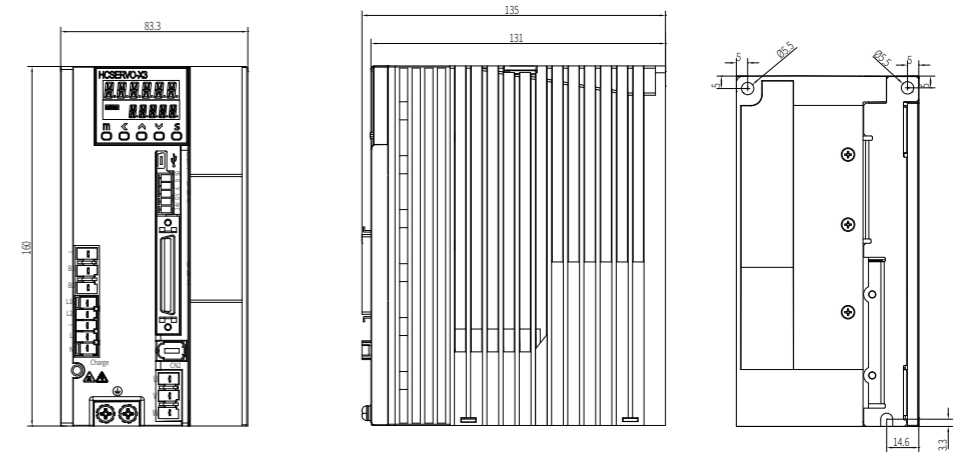

X2E Series Simple-type Servo Drive

Naming Rule

SV-X2E A - 075 - A - A 0 - 00 000

1 2 3 4 5 6 7

1 Product type	
A	Standard pulse type
N	CANopen bus-type

2 Power specifications	
005	50W
010	100W
020	200W
040	400W
075	750W
100	1KW
150	1.5KW
200	2KW
250	2.5KW

3 Voltage specifications	
A	AC220V

4 Control power	
A	AC power

5 Product iteration serial number	
0	N/A

6 Hardware type	
00	N/A

7 Software customized mark	
000	N/A

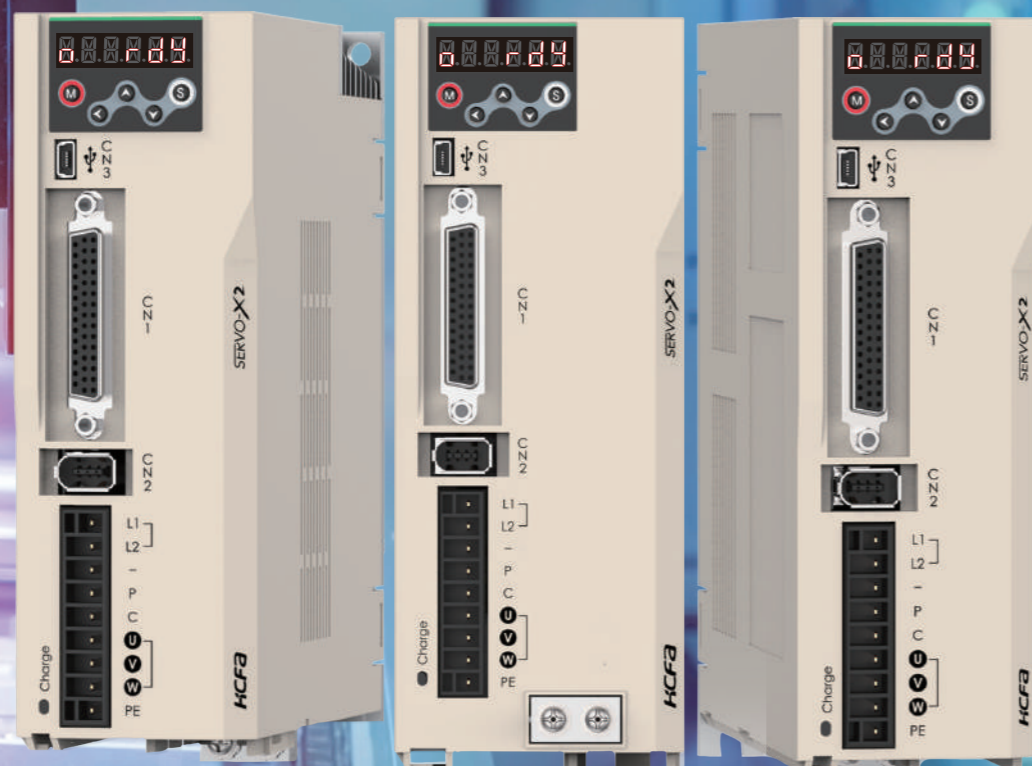

Compact size | Space optimized

General Specifications

Items	Specifications								
Models	005	010	020	040	075	100	150	200	250
Power (W)	50	100	200	400	750	1000	1500	2000	2500
Rated current (Arms)	0.9	1.2	2	3	4.5	6	10	12.5	15.6
Continuous running current (Arms)	0.9	1.2	2	3	4.5	6	10	12.5	15.6
Max. output current (Arms)	2.7	3.6	6	9	13.5	18	30	37.5	37.5
power specifications	Single-phase 220V 50~60Hz					three-phase 220V 50~60Hz			
Control mode	Six control mode: Position control, speed control, torque control, position/speed control, position/torque control, speed/torque control								
Applicable encoder	17bit								

Environment Specifications

Items	Specifications	
Temperature	Ambient temperature for use	0~55°C
	Ambient temperature for storage	-20~65°C
Humidity	Ambient humidity for use	20~85%RH or less(Without condensation)
	Ambient humidity for storage	20~85%RH or less(Without condensation)
Atmosphere for use& storage	Indoors(Not subject to direct sunlight); free from corrosive gas, flammable gas, oil mist, or dust	
Altitude	1000m or less above sea level	
Vibration	5.8m/s ² (0.6G) or less, 10~60Hz(No continuous operation allowed at frequency of resonance)	
Dielectric strength	1 minute at 1500 VAC across the primary and FG	

Technical Specifications

Items		Specifications		
Position control	Pulse input	Max input pulse frequency	Open-collector pulse input: Up to 200KHz, pulse width larger than 2.5us General input: Up to 500KHz, pulse width larger than 1 us High-speed input: Up to 4MHz, pulse width larger than 125ns	
		Input pulse form	Pulse+ direction, A-Phase + B-Phase, CW+CCW	
		Electronic gear setting	Electronic gear : A/B (Encoder resolution/10000000 < A/B < Encoder resolution/2.5)	
		Smoothing	Smoothing filter, FIR filter	
	Pulse output	Output pulse	Encoder position or pulse synchronization output	
		Division ratio	Arbitrary frequency division	
		Output pulse form	Differential output: A/B/ Z, Open collector output: Z-phase	
Internal position mode		Segment 1-16 internal position planning		
Speed control	Control method	Internal parameter P03.03 /0~16 segments speed selection can be realized by DI terminal combination		
	Torque limit function	Internal parameter setting		
Torque control	Control method	Set the speed instruction value by P03.25		
	Speed limit	Set the positive and negative internal speed limit by P03.27, P03.28		
Common functions	Control signal	I/O	8IN/5OUT	
	Analog signal	I/O	N/A	
	Speed monitoring		Provided	
	Vibration control		Provided	
	Adaptive notch filter		Provided	
	Auto-tuning		Provided	
	Encoder output division and multiplication		Provided	
	Dynamic brake		Provided	
	Regeneration function		A larger power braking resistor can be connected	
	Protective functions		Overvoltage, power supply error, overcurrent, overheat, overload, encoder error, over speed, position deviation too large, parameter error	
	Communication	USB	For PC communication (「Servostudio」connection)	
		Models	RS485	N:CANOPEN

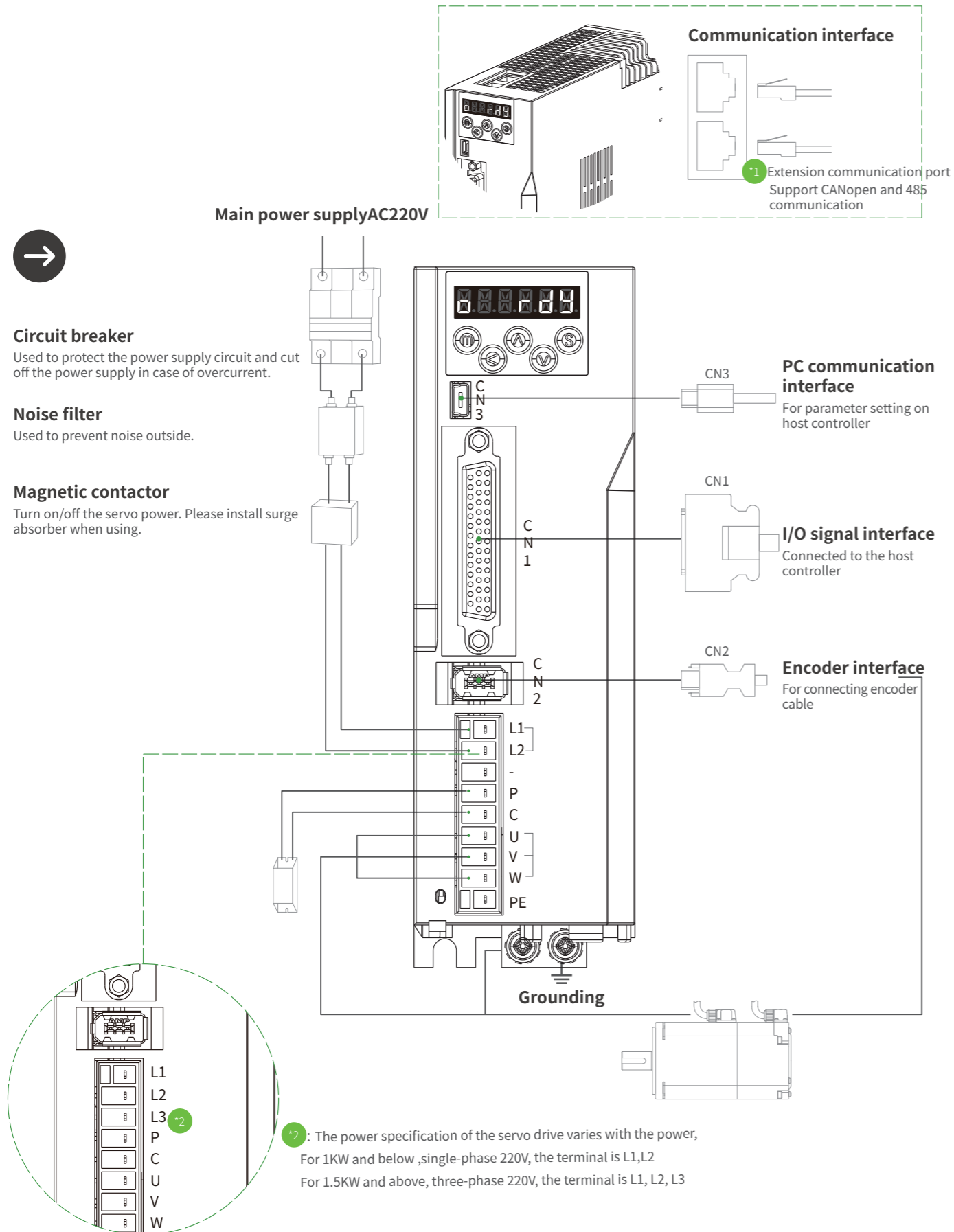

For models of 200W or less Unit:mm

Weight (KG)
0.84

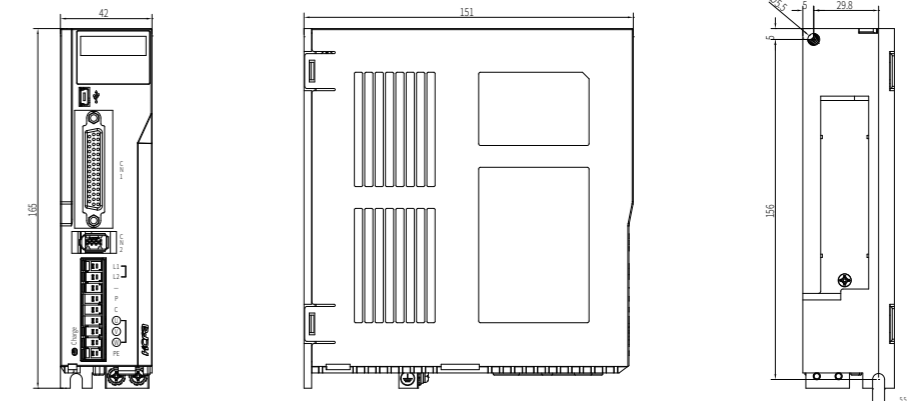

For models of 400W/750W/1KW Unit:mm

Weight (KG)
0.87

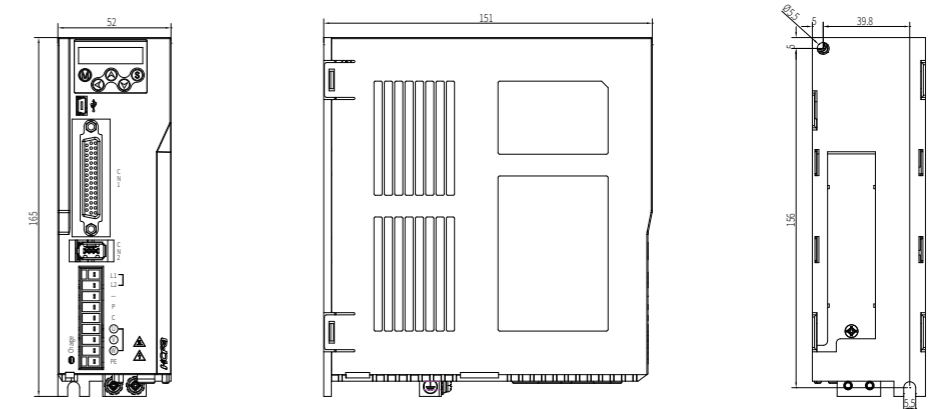

For models of 1.5KW/2KW/2.5KW Unit:mm

Weight (KG)
1.23

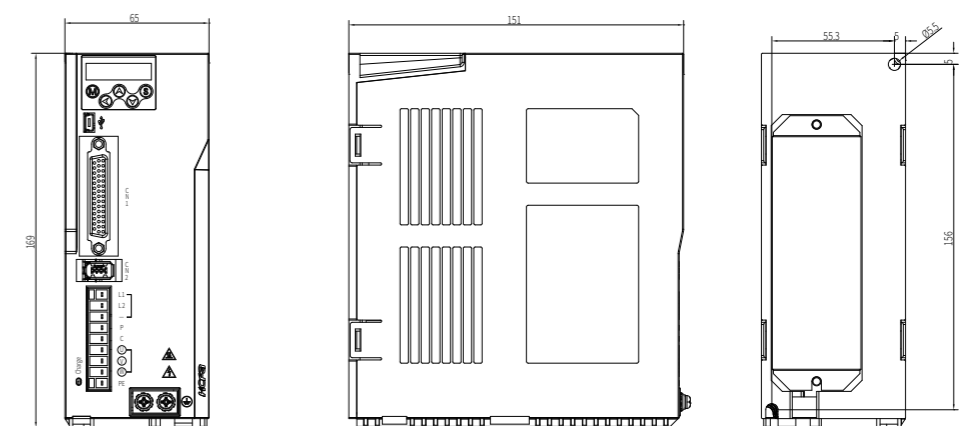

X2 Series

17BIT Absolute

50W-2.3KW
0.16N.m-15N.m

X6 Series

17BIT/23BIT Absolute

50W-7.5KW
0.16N.m-47.8N.m

Power specification

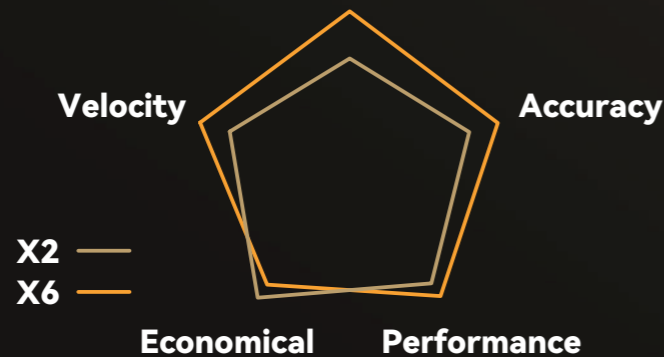

New manufacturing process

The newly-designed iron-core process makes the servo motor much smaller and lighter, 20% shorter than the previous generation

New structure design

The integrated structure of the front flange and housing to be stronger, matching with connector-type motor. IP67 protection level

New rotor design

The new design with 10-pole rotor + magnetic field analysis technology to reduce the width of pulsation and makes it smoother at low speed.



Full range of high, middle and low inertia!

MA

Low-inertia servo motor

Suitable for some occasions with light load and high-speed positioning. Quick response to start, accelerate and stop.

MM/MH

Medium/high inertia servo motor

Suitable for occasions with heavy load and high stability requirements.

MHH

Ultra-high inertia servo motor

Suitable for the same installation flange. With higher motor inertia, suitable for rollers and low-speed and stable occasions.

MQ

Flat and special flange servo motor

Under the same power, with different sizes of flange design. The servo motor becomes shorter, but with larger inertia. Also suitable for rollers and low-speed stable occasions.

MG

Low-speed and large-torque servo motor

With the characteristics of low rated speed and large output torque, suitable for heavy load occasions.

MGS

Low cogging cutting servo motor

Groove inclination design, which has lower cogging torque and good low-speed characteristics. At the same time, it can reach the maximum speed of 4000RPM with the Y7 series servo drive, which greatly shortens the idle travel time and improves the processing efficiency.

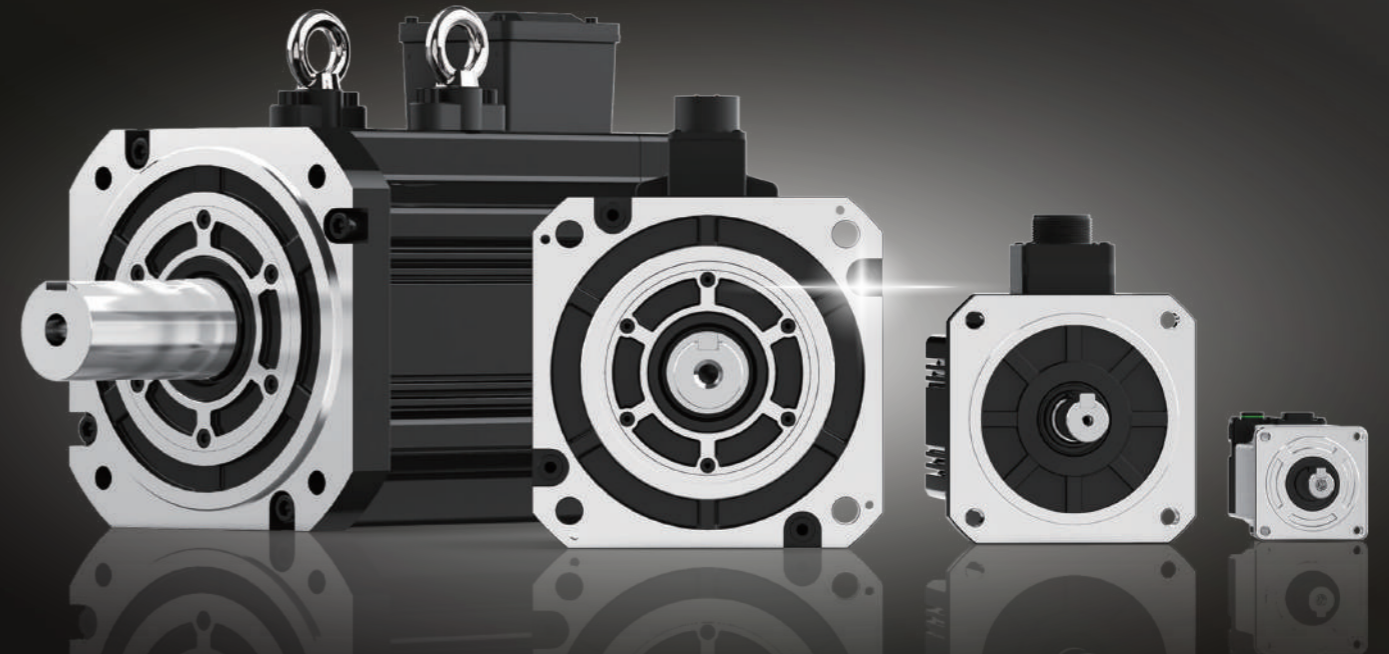

SV-X2 MA 040 A - N 2 C A - *****

1 2 3 4 5 6 7 8 Special specifications

1 Series name	
SV-X2 series	17BIT

2 Inertia specifications	
MA	Low inertia
MM	Middle inertia
MH	High inertia
MHH	Ultrahigh inertia
MQ	Special flange/Flat-type/small flange
MG	Low-speed & high-torque
MS	Ultrahigh speed

3 Power specifications	
005	50W
010	100W
015	150W
020	200W
040	400W
075	750W
080	800W
085	850W
100	1KW
130	1.3KW
150	1.5KW
180	1.8KW
200	2KW
230	2.3KW

4 Design number	
A/B/C/E/F/H/K/S	

5 Brake specifications	
N	No brake
B	With brake

6 Voltage specifications	
2	AC220V

7 Specifications	
K	Keyway shaft/no oil seal
L	Keyway shaft/with oil seal
C	Connector type/ keyway shaft/with oil seal*1
D	Connector type/ keyway shaft/no oil seal*1
J	Compact type(customized)

8 Encoder specifications	
N	Single-turn 17bit incremental
A	Multi-turn 17bit absolute

9 Customization	
**	N/A

*1: From the 2nd quarter of 2021, our company started releasing connector-type servo motor with 40-80 flanges as the regular model. Lead-wire servo motors will be discontinued from December 2021, if still needed, the customized application process is required. For details, refer to page 67 or consult our sales staff.



E.g. 17bit incremental 220v 400W MA Low inertia Naming rule SV-X2 MA 040A-N2CN
17bit absolute 220v 400W MA Low inertia Naming rule SV-X2 MA 040A-N2CA

X2 Series Servo Motor

Series name	Specifications	50W	100W	150W	200W	400W	750W	1000W	1500W	2000W
X2 Series Low inertia	Models		X2MA020A	X2MA040A	X2MA075A	X2MA100A	X2MA150A	X2MA200A		
	Flange		60	60	80	100	100	100		
	Rated [Peak Torque]		0.64 [1.91]	1.27 [3.82]	2.39 [7.16]	3.18 [9.55]	4.77 [14.3]	6.37 [19.1]		
X2-MM Middle inertia	Inertia:No brake [with brake]		0.16 [0.17]	0.28 [0.29]	0.96 [1.07]	2.03 [2.35]	2.84 [3.17]	3.68 [4.01]		
	Rotation speed: Rated [Max. speed]		3000 [6000*4]	3000 [6000*4]	3000 [6000*4]	3000 [6000*4]	3000 [6000*4]	3000 [6000*4]		
	220V servo motor									
X2-MH High inertia	Models		X2MH010A	X2MH015A	X2MH020A	X2MH040A	X2MH075A	X2MH100A	X2MH150A	X2MH200A
	Flange		40	40	60	60	80	130	130	130
	Rated [Peak Torque]		0.32 [1.11]	0.477 [1.43]	0.64 [2.23]	1.27 [4.46]	2.39 [8.36]	4.77 [14.3]	7.16 [21.5]	9.55 [28.6]
X2-MHH Ultrahigh inertia	Inertia:No brake [with brake]		0.071 [0.074]	0.13 [0.133]	0.29 [0.31]	0.56 [0.58]	1.56 [1.66]	30.8 [32]	9.16 [10.4]	12.1 [13.3]
	Rotation speed: Rated [Max. speed]		3000 [6500]	3000 [6000]	3000 [6500*4]	3000 [6500*4]	3000 [6000*4]	3000 [3000]	2000 [3000]	2000 [3000]
	220V servo motor									
X2-MQ Special flange Flat-type small flange	Models		X2MQ010A	X2MQ020A	X2MQ040A	X2MQ075A	X2MQ100E			
	Flange		60	80	80	80	80			
	Rated [Peak Torque]		0.32 [0.96]	0.637 [1.91]	1.27 [3.82]	2.39 [8.36]	3.15 [3.2]	3.185 [11.13]		
Series name	Inertia:No brake [with brake]		0.16 [0.18]	0.47 [0.5]	0.87 [0.9]	0.87 [0.9]	3000 [6500*4]	2 [2.1]		
	Rotation speed: Rated [Max. speed]		3000 [6500]	3000 [6500]	3000 [6500*4]	3000 [6500*4]	3000 [6500*4]	3000 [6000*4]		
	220V servo motor									
X2-MG Low-speed & high-torque	Specifications		1KW	850W	1.3KW	1.8KW	2.3KW			
	Models		X2MG075A	X2MG085A	X2MG130A	X2MG180A	X2MG230A			
	Flange		80	130	130	130	130			
Series name	Rated [Peak Torque]		4.77 [14.3]	5.41 [16.2]	8.28 [24.84]	11.5 [34.5]	15.7 [33]			
	Inertia:No brake [with brake]		2.88 [3]	14 [15.2]	20.2 [21.4]	26 [27.2]	12.7 [14.2]			
	Rotation speed: Rated [Max. speed]		1500 [2000]	1500 [3000]	1500 [3000]	1500 [3000]	1500 [2000]			
X2-MS Ultrahigh speed	Specifications		800W	1.5KW	2.0KW					
	Models		X2MS080A	X2MS150B	X2MS200B					
	Flange		60	130	130					
Series name	Rated [Peak Torque]		1.27 [3.81]	4.77 [14.3]	7.16 [21.5]	9.55 [28.6]				
	Inertia:No brake [with brake]		1.15 [*3]	9.16 [10.4]	12.1 [13.3]	16.85 [18.05]				
	Rotation speed: Rated [Max. speed]		6000 [10000]	2000 [5000]	2000 [5000]	2000 [5000]				
Series name	220V servo motor									
	Models									
	Flange									

NOTE: *1 indicates the encoder bits.

*2: Under development

*3: Indicates there is no model with the brake.

*4: The maximum speed of the servo motor varies due to the design difference of the servo drive

Servo Motor Specifications

200 W 400 W 750 W 1 KW 1.5 KW 2 KW

Items	Unit	X2MA020A	X2MA040A	X2MA075A	X2MA100A	X2MA150A	X2MA200A	
Rated power	W	200	400	750	1000	1500	2000	
Rated voltage	V	220	220	220	220	220	220	
Fitting flange size	mm	60	60	80	100	100	100	
Rated torque	N.m	0.64	1.27	2.39	3.18	4.77	6.37	
Instantaneous max. torque	N.m	1.91	3.82	7.16	9.55	14.3	19.1	
Rated speed	r/min	3000	3000	3000	3000	3000	3000	
Max. speed	r/min	6000	6000	6000	5000	5000	5000	
	NOTE	*1	*1	*1				
NOTE *1: The above data is only the theoretical performance of the motor design, so the motor performance may vary according to the different series of servo drives.								
Rated current	Arms	1.7	2.7	4.2	6.6	8.2	11.3	
Instantaneous max. current	Arms	6.5	10.2	17.4	28	35	48	
Moment of inertia	No brake	$\times 10^{-4}$ Kg.m ²	0.16	0.28	0.96	2.03	2.84	3.68
	With brake	$\times 10^{-4}$ Kg.m ²	0.17	0.29	1.07	2.35	3.17	4.01
Torque constant	N.m/A	0.427	0.488	0.583	0.52	0.628	0.607	
Induced voltage constant per phase	mV[r/min]	14.5	17.9	21.33	18.15	21.92	21.247	
Rated power rate	No brake	KW/S	25.6	57.6	59.5	49.82	80.12	110.26
	With brake	KW/S	24.1	55.6	53.4	43.03	71.775	101.19
Mechanical time constant	No brake	ms	0.775	0.561	0.463	0.619	0.425	
	With brake	ms	0.824	0.581	0.516	0.717	0.566	0.463
Electrical time constant	ms	6.3	6.1	12.7	7.22	8.08	9.37	
Phase q-axis/d-axis inductance	mH	19/5.6	10.7/7.5	7.6/4.9	—	—	—	
Weight: No brake[with brake]	kg	0.9 [1.3]	1.28 [1.67]	2.25 [3.01]	3.5 [4.5]	4.4 [5.4]	5.3 [6.3]	
Permissible load	Radial load	N	245	245	392	392	392	
	Axial load	N	98	98	147	147	147	
Brake specification	Rated voltage	V	DC24V \pm 10%					
	Rated current	A	0.36	0.36	0.42	0.81 \pm 10%	0.81 \pm 10%	0.81 \pm 10%
	Brake power	w	9	9	10	20	20	20
	Static friction torque	N.m	1.6 or more	1.6 or more	3.8 or more	7.8 or more	7.8 or more	7.8 or more
Note: Holding brake	Suction time	ms	50 or less	50 or less	70 or less	50 or less	50 or less	50 or less
	Release time	ms	20 or less	20 or less	20 or less	15 or less	15 or less	15 or less
	Release voltage	ms	DC1V or more					

Torque characteristics

Instantaneous operation range (red line) Continuous operation range (blue line)

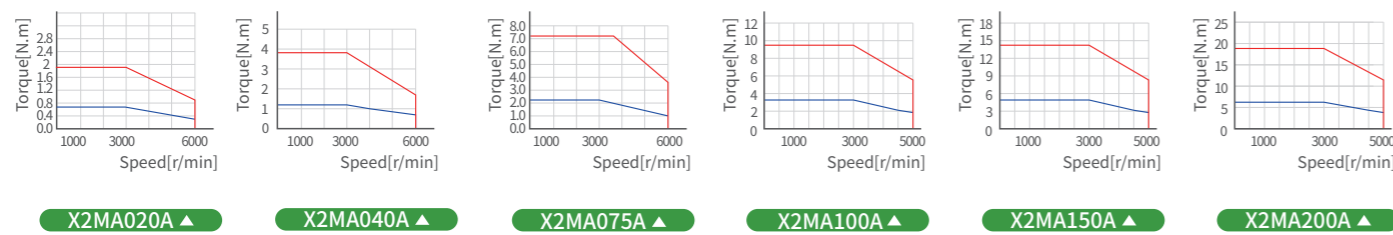

External Dimensions for Servo Motor

Unit(mm)

Models	X2MA020A	X2MA040A	X2MA075A	X2MA100A	X2MA150A	X2MA200A
LC	60	60	80	100	100	100
LA	φ70	φ70	φ90	φ115	φ115	φ115
LB	φ50	φ50	φ70	φ95	φ95	φ95
LZ	4-φ5.4	4-φ5.4	4-φ6	4-φ9	4-φ9	4-φ9
LR	30	30	35	55	55	55
S	φ14 h6	φ14 h6	φ19 h6	φ19 h6	φ19 h6	φ19 h6
LL no brake [with brake]	73.5 [103]	93.2 [122.7]	105 [138.5]	123.5 [150.5]	142 [169]	161 [188]
LN no brake [with brake]	—	—	—	96.5 [123.5]	115 [142]	134 [161]
LG	6.5	6.5	8	10	10	10
LE	3	3	3	3	3	3
LM1	—	—	—	111.5 [138.5]	130 [157]	149 [176]
LM2	—	—	—	— [105]	— [123.5]	— [142.5]
LM3	—	—	—	62	80.5	99.5
LH1	44.5	44.5	54.5	103	103	103
LH2	—	—	—	66	66.5	66.5
LH3	—	—	—	55	55	55
LK	25	25	25	42	42	42
T	5	5	6	6	6	6
KW	5 h9	5 h9	6 h9	6 h9	6 h9	6 h9
KH	11	11	15.5	15.5	15.5	15.5
TP	M5depth12	M5depth12	M5depth10	M5depth12	M5depth12	M5depth12
H	H-type cable length for lead-wire type	210	210	210	—	—

X2MA020A / X2MA040A / X2MA075A

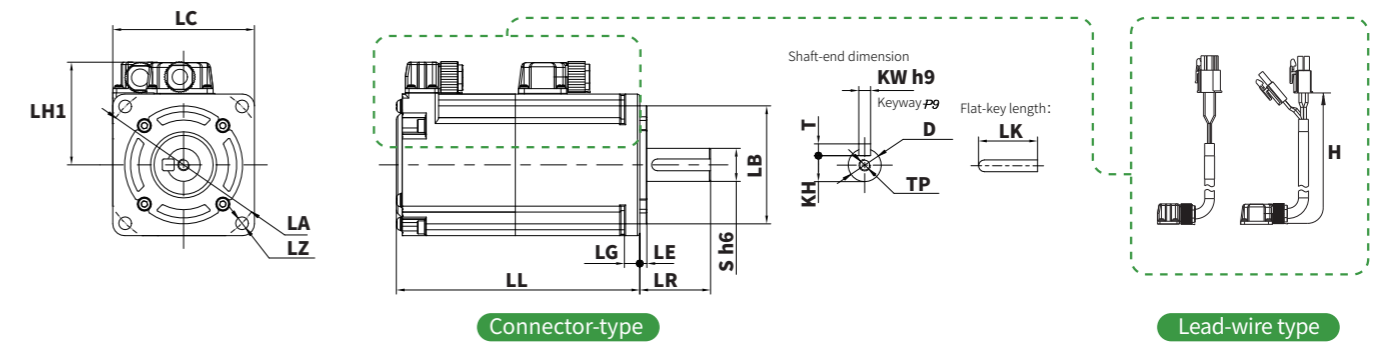

X2MA100A / X2MA150A / X2MA200A

NOTE *2: For X2 series servo motors, the lead-wire types are needed to be customized. For details, please contact our sales department.

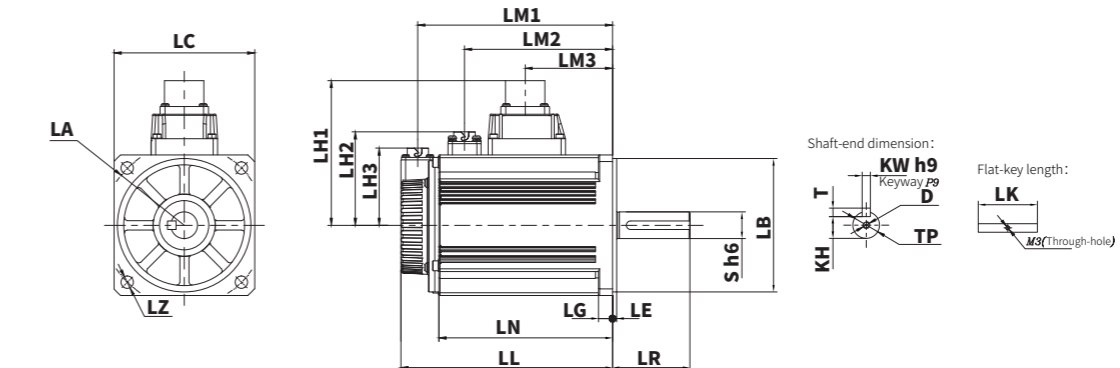

Servo Motor Specifications

1 KW 1.5 KW 2 KW

Items	Unit	X2MM100A	X2MM150A	X2MM200A	
Rated power	W	1000	1500	2000	
Rated voltage	V	220	220	220	
Fitting flange size	mm	130	130	130	
Rated torque	N.m	4.77	7.16	9.55	
Instantaneous max. torque	N.m	14.3	21.5	28.6	
Rated speed	r/min	2000	2000	2000	
	r/min	3000	3000	3000	
Max. speed					
Rated current	Arms	5.2	8	9.9	
Instantaneous max. current	Arms	15.6	24	30	
Moment of inertia	No brake	$\times 10^{-4} \text{Kg.m}^2$	6.18	9.16	12.1
	With brake	$\times 10^{-4} \text{Kg.m}^2$	7.4	10.4	13.3
Torque constant	N.m/A	0.918	0.895	0.9645	
Induced voltage constant per phase	mV[r/min]	33.65	34.84	37.95	
Rated power rate	No brake	KW/S	36.8	56	75.4
	With brake	KW/S	30.7	49.3	68.6
Mechanical time constant	No brake	ms	1.51	1.16	1.05
	With brake	ms	1.81	1.3	1.16
Electrical time constant	ms	11.1	14.6	15.38	
Phase q-axis/d-axis inductance	mH	8.4/4.3	5.8/2.9	4.9/2.6	
Weight: No brake[with brake]	kg	4.67 [6.27]	5.87[7.47]	12.1[13.3]	
Permissible load	Radial load	N	490	490	490
	Axial load	N	196	196	196
Brake specification	Rated voltage	V	DC24V \pm 10%		
	Rated current	A	0.9	0.9	0.9
	Brake power	w	22	22	22
	Static friction torque	N.m	14 or more	14 or more	14 or more
Note: Holding brake	Suction time	ms	100 or less	100 or less	100 or less
	Release time	ms	60 or less	60 or less	60 or less
	Release voltage	ms	DC1V or less		

Torque characteristics

Instantaneous operation range Continuous operation range

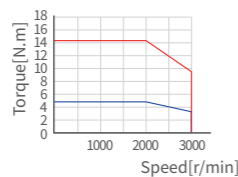

X2MM100A▲



X2MM150A▲



X2MM200A▲

External Dimensions for Servo Motor

Unit(mm)

Models	X2MM100A-□2L□	X2MM150A-□2L□	X2MM200A-□2L□
LC	130	130	130
LA	φ145	φ145	φ145
LB	φ110	φ110	φ110
LZ	4-φ9	4-φ9	4-φ9
LR	55	55	55
S	φ22 h6	φ22 h6	φ22 h6
LL no brake [with brake]	107.5 [127.5]	121.5 [141.5]	135.5 [155.5]
LN no brake [with brake]	80 [100]	94 [114]	108 [128]
LG	12	12	12
LE	6	6	6
LH1	115	115	115
LH3	56.5	56.5	56.5
LM1no brake [with brake]	95.5 [115.5]	109.5 [129.5]	123.5 [143.5]
LM3	41	55	69
LK	45	45	45
T	7	7	7
KW	8 h9	8 h9	8 h9
KH	18	18	18
TP	M6depth20	M6depth20	M6deep20

X2MM100A / X2MM150A / X2MM200A [Aviation connector]

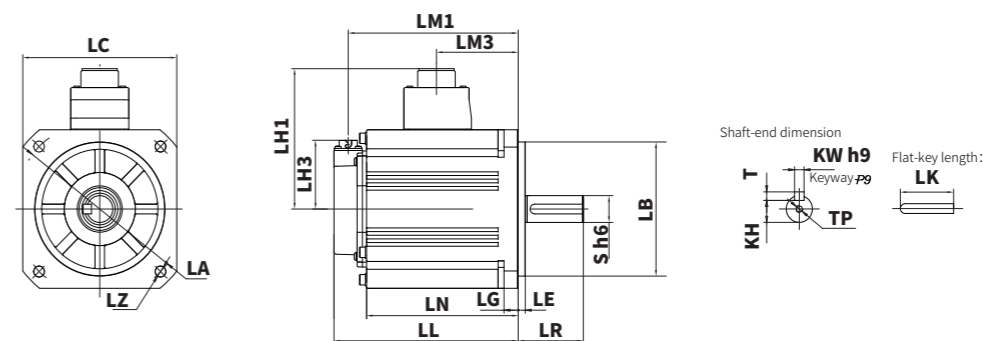

Servo Motor Specifications 50W 100W 150W 200W 400W 750W

Items	Unit	X2MH005A	X2MH010A	X2MH015A	X2MH020A	X2MH040A	X2MH075A	
Rated power	W	50	100	150	200	400	750	
Rated voltage	V	220	220	220	220	220	220	
Fitting flange size	mm	40	40	40	60	60	80	
Rated torque	N.m	0.16	0.32	0.477	0.64	1.27	2.39	
Instantaneous max. torque	N.m	0.56	1.11	1.43	2.23	4.46	8.36	
Rated speed	r/min	3000	3000	3000	3000	3000	3000	
	r/min	6500	6500	6000	6500	6500	6000	
Max. speed					*1	*1	*1	
	NOTE	NOTE *1: The above data is only the theoretical performance of the motor design, so the motor performance may vary according to the different series of servo drives.						
Rated current	Arms	1.1	1.1	1.5	1.4	2.1	3.8	
Instantaneous max. current	Arms	3.89	3.89	4.5	4.87	7.36	13.3	
Moment of inertia	No brake	x10 ⁻⁴ Kg.m ²	0.038	0.071	0.13	0.29	0.56	1.56
	With brake	x10 ⁻⁴ Kg.m ²	0.042	0.074	0.133	0.31	0.58	1.66
Torque constant	N.m/A	0.168	0.327	0.33	0.5	0.67	0.648	
Induced voltage constant per phase	mV[r/min]	5	11.1	12.2	14.61	20.85	22.65	
Rated power rate	No brake	KW/S	6.7	14.4	17.5	14.1	28.8	36.6
	With brake	KW/S	6.1	13.8	17.1	13.2	27.8	34.4
Mechanical time constant	No brake	ms	2.6	1.67	1.9	1.57	1.24	0.97
	With brake	ms	2.85	1.74	1.94	1.68	1.29	1.03
Electrical time constant	ms	0.89	1.1	1.22	2.58	2.97	6.59	
Phase q-axis/d-axis inductance	mH	5.1/3.4	9.4/6.3	7.2/4.8	10.2/5.8	9.2/6.5	6/3.3	
Weight: No brake[with brake]	kg	0.33 [0.55]	0.45 [0.66]	0.83 [0.69]	0.87 [1.27]	1.22 [1.61]	2.25 [3.01]	
Permissible load	Radial load	N	68	68	68	245	245	392
	Axial load	N	58	58	58	98	98	147
Brake specification	Rated voltage	V	DC24V±10%					
	Rated current	A	0.25	0.25	0.375	0.36	0.36	0.42
	Brake power	w	6	6	9	9	9	10
	Static friction torque	N.m	0.38 or more	0.38 or more	0.58 or more	1.6 or more	1.6 or more	3.8 or more
Note: Holding brake	Suction time	ms	35 or less	35 or less	50 or less	50 or less	50 or less	70 or less
	Release time	ms	20 or less	20 or less	20 or less	20 or less	20 or less	20 or less
	Release voltage	ms	DC1V or more					

Torque characteristics

Instantaneous operation range Continuous operation range

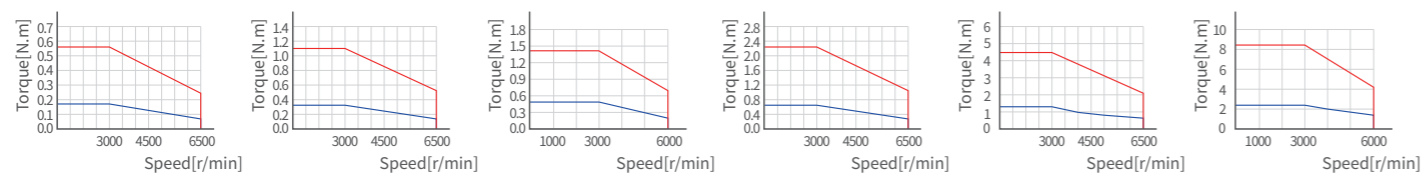

X2MH005A ▲ X2MH010A ▲ X2MH015A ▲ X2MH020A ▲ X2MH040A ▲ X2MH075A ▲

External Dimensions for Servo Motor

Unit(mm)

Models	X2MH005A	X2MH010A	X2MH015A	X2MH020A	X2MH040A	X2MH075A
LC	40	40	40	60	60	80
LA	φ46	φ46	φ46	φ70	φ70	φ90
LB	φ30	φ30	φ30	φ50	φ50	φ70
LZ	2-φ4.3	2-φ4.3	2-φ4.3	4-φ5.4	4-φ5.4	4-φ6.5
LR	25	25	25	30	30	35
S	φ8 h6	φ8 h6	φ8 h6	φ14 h6	φ14 h6	φ19 h6
LL no brake [with brake]	57 [91]	71 [105]	93.8[127.8]	70.5[100]	87.5 [117]	94.5[128.5]
LG	5	5	5	6.5	6.5	8
LE	3	3	3	3	3	3
LH	35	35	35	44.5	44.5	54.5
LK	14	14	14	25	25	25
T	3	3	3	5	5	6
KW	3 h9	3 h9	3 h9	5 h9	5 h9	6 h9
KH	6.2	6.2	6.2	11	11	15.5
TP	M3depth6	M3depth6	M3depth6	M5depth12	M5depth12	M5depth12
H H-type cable length for lead-wire type	210	210	210	210	210	210

▼ X2MH005A / X2MH010A / X2MH015A/X2MH20A/X2MH040A/X2MH075A

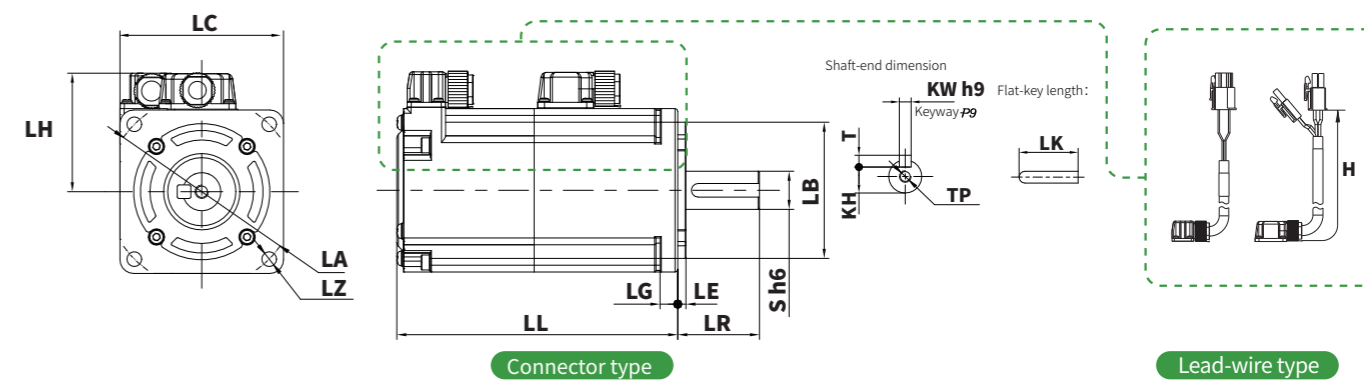

*2: X2 series motor and wire type products are customized products. If there is any demand, please contact our sales department.

Servo Motor Specifications

1 KW 1.5 KW

Items	Unit	X2MH100A	X2MH150A	
Rated power	W	1000	1500	
Rated voltage	V	220	220	
Fitting flange size	mm	130	130	
Rated torque	N.m	4.77	7.16	
Instantaneous max. torque	N.m	14.3	21.5	
Rated speed	r/min	2000	2000	
	r/min	3000	3000	
Max. speed				
Rated current	Arms	5.2	8	
Instantaneous max. current	Arms	15.6	24	
Moment of inertia	No brake	$\times 10^{-4} \text{Kg.m}^2$	30.8	
	With brake	$\times 10^{-4} \text{Kg.m}^2$	32	
Torque constant	N.m/A	0.918	0.895	
Induced voltage constant per phase	mV[r/min]	33.65	34.84	
Rated power rate	No brake	KW/S	7.39	
	With brake	KW/S	7.11	
Mechanical time constant	No brake	ms	7.54	
	With brake	ms	7.84	
Electrical time constant	ms	11.1	14.63	
Phase q-axis/d-axis inductance	mH	8.4/4.3	5.8/2.9	
Weight: No brake[with brake]	kg	6.4 [8]	7.8[9.4]	
Permissible load	Radial load	N	490	
	Axial load	N	196	
Brake specification	Rated voltage	V	DC24V \pm 10%	
	Rated current	A	0.9	0.9
	Brake power	W	22	22
	Static friction torque	N.m	14 or more	14 or more
Note: Holding brake	Suction time	ms	100 or less	100 or less
	Release time	ms	60 or less	60 or less
	Release voltage	ms	DC1V or more	

Torque characteristics

Instantaneous operation range Continuous operation range

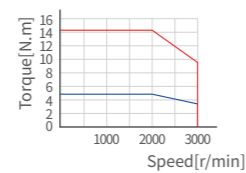

X2MH100A ▲



X2MH150A ▲

External Dimensions for Servo Motor

Unit(mm)

Models	X2MH100A-□2L□(Aviation connector)	X2MH150A-□2L□(Aviation connector)
LC	130	130
LA	φ145	φ145
LB	φ110	φ110
LZ	4-φ9	4-φ9
LR	55	55
S	φ22 h6	φ22 h6
LL no brake [with brake]	135.5[155.5]	149.5 [169.5]
LN no brake [with brake]	108[128]	122[142]
LG	12	12
LE	6	6
LH1	115	115
LH3	56.5	56.5
LM1no brake [with brake]	123.5 [143.5]	137.5 [157.5]
LM3	69	83
LK	45	45
T	7	7
KW	8 h9	8 h9
KH	18	18
TP	M6depth20	M6depth20

X2MH100A/X2MH150A[Aviation connector]

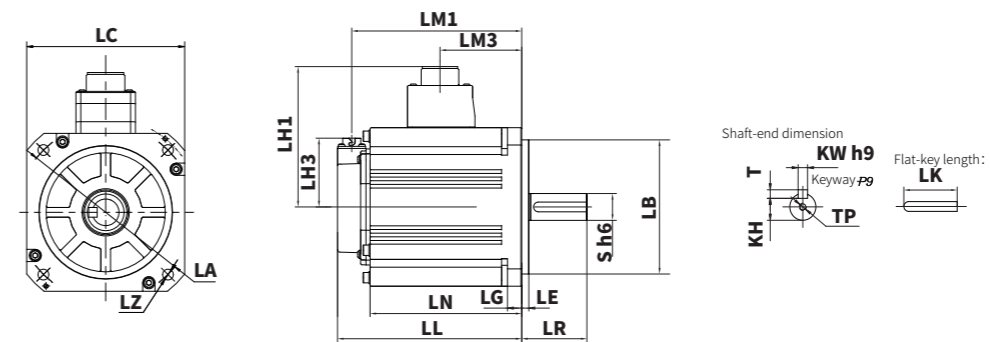

Servo Motor Specifications

100 W 200 W 400 W 750 W

Items	Unit	X2MH010H	X2MH020H	X2MH040H	X2MH075H	
Rated power	W	100	200	400	750	
Rated voltage	V	220	220	220	220	
Fitting flange size	mm	40	60	60	80	
Rated torque	N.m	0.32	0.64	1.27	2.39	
Instantaneous max. torque	N.m	1.11	2.23	4.46	8.36	
Rated speed	r/min	3000	3000	3000	3000	
	r/min	6500	6500	6500	6000	
Max. speed	NOTE		*1	*1	*1	
	NOTE *1: The above data is only the theoretical performance of the motor design, so the motor performance may vary according to the different series of servo drives.					
Rated current	Arms	0.92	1.4	2.4	3.8	
Instantaneous max. current	Arms	3.6	6.9	8.2	18.8	
Moment of inertia	No brake	$\times 10^{-4}$ Kg.m ²	0.092	0.47	0.73	3.15
	With brake	$\times 10^{-4}$ Kg.m ²	0.095	0.49	0.75	3.2
Torque constant	N.m/A	0.327	0.5	0.531	0.648	
Induced voltage constant per phase	mV[r/min]	13.3	14.61	20.4	22.65	
Rated power rate	No brake	KW/S	11.13	8.71	22.09	18.1
	With brake	KW/S	10.78	8.36	21.5	17.85
Mechanical time constant	No brake	ms	2.23	2.54	1.15	1.95
	With brake	ms	2.3	2.65	1.18	1.98
Electrical time constant	ms	0.986	2.58	4.1	6.59	
Phase q-axis/d-axis inductance	mH	11.9/8	10.2/5.8	6.9/4.3	6/3.3	
Weight: No brake[with brake]	kg	0.44[0.65]	0.95 [1.29]	1.45 [1.85]	2.65 [3.13]	
Permissible load	Radial load	N	68	245	245	392
	Axial load	N	58	98	98	147
Brake specification	Rated voltage	V	DC24V±10%			
	Rated current	A	0.25	0.36	0.36	0.42
	Brake power	w	6	9	9	10
	Static friction torque	N.m	0.38 or more	1.6 or more	1.6 or more	3.8 or more
	Note: Holding brake					
Suction time	ms	35 or less	50 or less	50 or less	70 or less	
Release time	ms	20 or less	20 or less	20 or less	20 or less	
Release voltage	ms	DC1V or more				

External Dimensions for Servo Motor

Unit(mm)

Models	X2MH010H	X2MH020H(Lead-wire type)	X2MH040H	X2MH075H(Lead-wire type)
LC	40	60	60	80
LA	φ46	φ70	φ70	φ90
LB	φ30	φ50	φ50	φ70
LZ	2-φ4.3	4-φ5.5	4-φ5.5	4-φ6.6
LR	25	30	30	35
S	φ8 h6	φ14 h6	φ14 h6	φ19 h6
LL no brake [with brake]	76.7 [110.7]	82.4 [111.9]	98.5 [128]	122 [167]
LG	5	6.5	6.5	8
LE	3	3	3	3
LH1	34.5	43.5	43.5	53.5
LK	14	25	25	25
T	3	5	5	6
KW	3 h9	5 h9	5 h9	6 h9
KH	6.2	11	11	15.5
TP	M3depth6	M5depth12	M5depth12	M5depth12
H	H-type cable length for lead-wire type	210	210	210

X2MH010H / X2MH020H / X2MH040H / X2MH075H

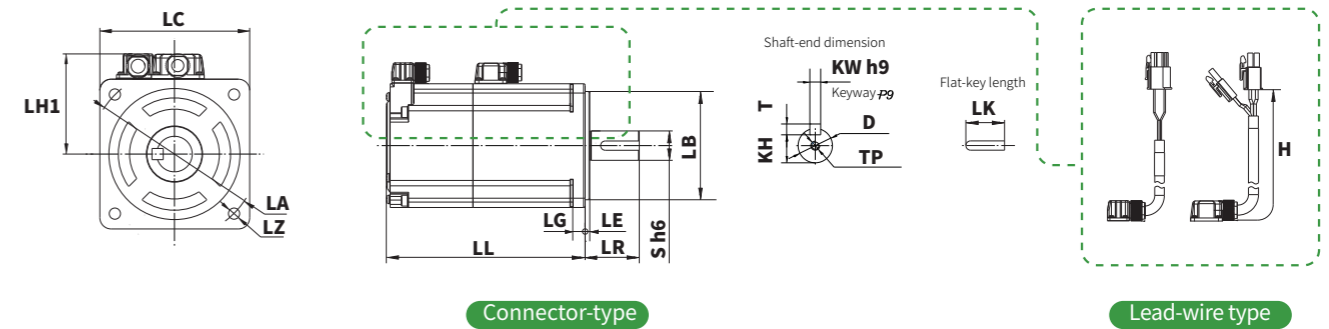

NOTE *2: For X2 series servo motors, the lead-wire types are needed to be customized. For details, please contact our sales department.

Torque characteristics

Instantaneous operation range Continuous operation range

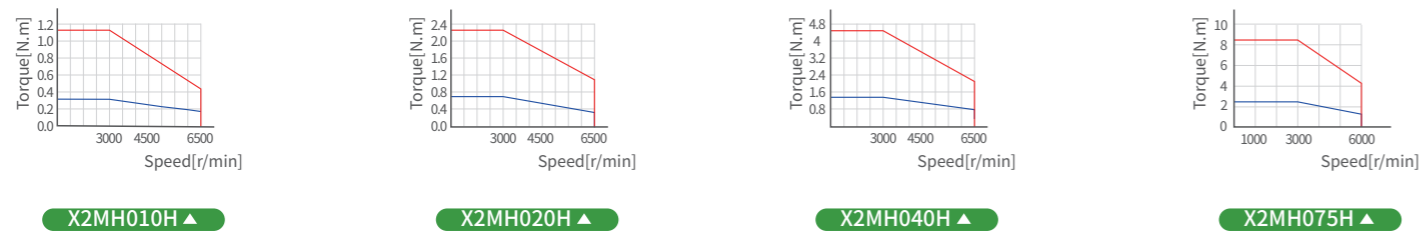

Servo Motor Specifications 100 W 200 W 400 W 1 KW

Items	Unit	X2MQ010A	X2MQ020A	X2MQ040A	X2MQ100E	
Rated power	W	100	200	400	1000	
Rated voltage	V	220	220	220	220	
Fitting flange size	mm	60	80	80	80	
Rated torque	N.m	0.32	0.637	1.27	3.185	
Instantaneous max. torque	N.m	0.96	1.91	3.82	11.13	
Rated speed	r/min	3000	3000	3000	3000	
Max. speed	r/min	6500	6500	6500	6000	
	NOTE			*1	*1	
NOTE *1: The above data is only the theoretical performance of the motor design, so the motor performance may vary according to the different series of servo drives.						
Rated current	Arms	0.95	2	2.6	5.7	
Instantaneous max. current	Arms	2.8	6.4	8.4	21.2	
Moment of inertia	No brake	$\times 10^{-4}$ Kg.m ²	0.16	0.47	0.87	2
	With brake	$\times 10^{-4}$ Kg.m ²	0.18	0.5	0.9	2.1
Torque constant	N.m/A	0.369	0.318	0.488	0.552	
Induced voltage constant per phase	mV[r/min]	11.6	12.2	19.6	21.2	
Rated power rate	No brake	KW/S	6.4	8.63	18.5	50.7
	With brake	KW/S	5.69	8.12	17.92	48.31
Mechanical time constant	No brake	ms	2.96	2.51	1.51	0.85
	With brake	ms	3.33	2.67	1.57	0.897
Electrical time constant	ms	1.76	3.52	5.41	7.6	
Phase q-axis/d-axis inductance	mH	13.9/7.8	7.3/3.9	9/4.9	3.8/2.6	
Weight: No brake[with brake]	kg	0.68 [0.92]	1.24 [1.74]	1.6 [2.1]	2.68 [3.45]	
Permissible load	Radial load	N	68	245	245	392
	Axial load	N	58	98	98	147
Brake specification	Rated voltage	V	DC24V±10%			
	Rated current	A	0.9	0.9	0.9	0.42
	Brake power	w	22	22	22	10
	Static friction torque	N.m	0.38-1.1	1.6 or more	1.6 or more	3.8 or more
	Note: Holding brake					
Suction time	ms	60 or less	60 or less	60 or less	70 or less	
Release time	ms	40 or less	40 or less	40 or less	20 or less	
Release voltage	ms	DC1.5V or more				

Torque characteristics Instantaneous operation range Continuous operation range

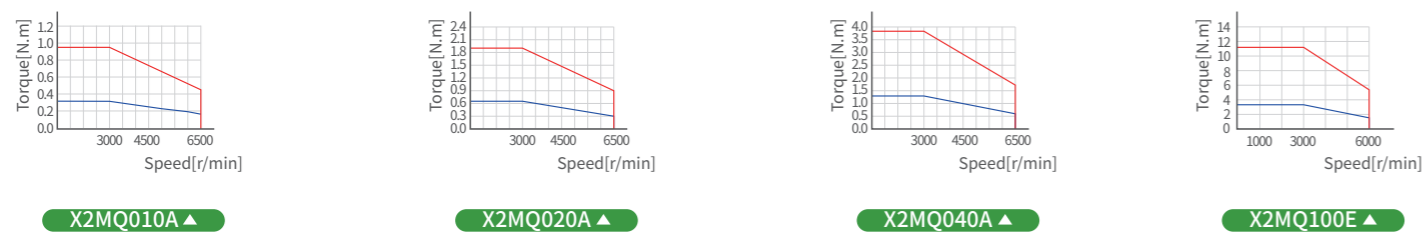

External Dimensions for Servo Motor

Unit(mm)

Models	X2MQ010A(Lead-wire type)	X2MQ020A(Lead-wire type)	X2MQ040A(Lead-wire type)	X2MQ100E
LC	60	80	80	80
LA	φ70	φ90	φ90	φ90
LB	φ50	φ70	φ70	φ70
LZ	4-φ5.4	4-φ6	4-φ6	4-φ6.5
LR	25	30	30	35
S	φ8 h6	φ11 h6	φ14 h6	φ19 h6
LL no brake [with brake]	61 [80.5]	66 [90]	76.8 [100.8]	108 [141.5]
LG	6.5	8	8	8
LE	3	3	3	3
LF	21	26	26	—
LP	φ14	φ19.7	φ19.7	—
LH1	43.5	53.5	53.5	53.5
LK	14	20	22	25
T	3	4	5	6
KW	3 h9	4 h9	5 h9	6 h9
KH	6.2	8.5	11	15.5
TP	M3depth6	M4depth8	M5depth12	M5depth12
H	H-type cable length for lead-wire type	210	210	210

X2MQ010A / X2MQ020A / X2MQ040A / X2MQ100E

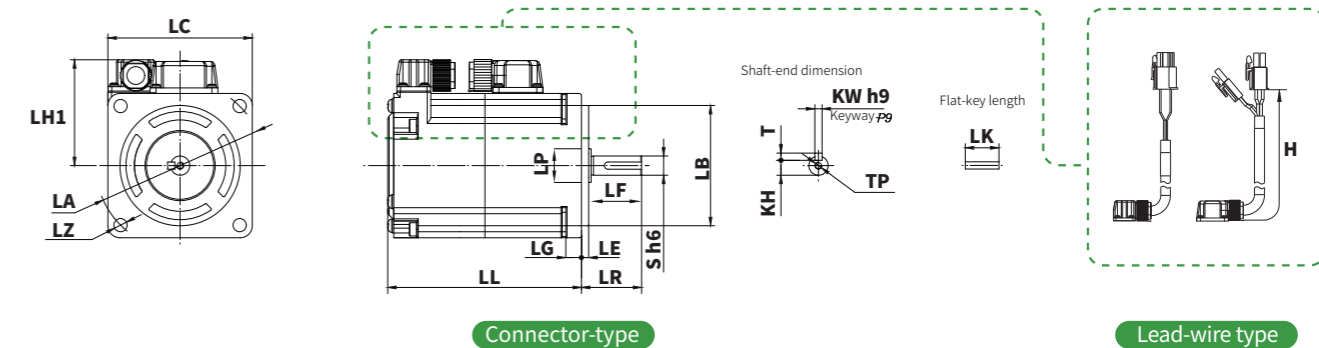

NOTE *2: For X2 series servo motors, the lead-wire types are needed to be customized. For details, please contact our sales department.

Servo Motor Specifications

750 W 850 W 1 KW 1.3 KW 1.8 KW 2.3 KW

Items	Unit	X2MG075A	X2MG085A	X2MG100A	X2MG130A	X2MG180A	X2MG230A	
Rated power	W	750	850	1000	1300	1800	2300	
Rated voltage	V	220	220	220	220	220	220	
Fitting flange size	mm	80	130	130	130	130	130	
Rated torque	N.m	4.77	5.41	9.55	8.28	11.5	15	
Instantaneous max. torque	N.m	14.3	16.2	28.6	24.84	34.5	33	
Rated speed	r/min	1500	1500	1000	1500	1500	1500	
Max. speed	r/min	2000	3000	1500	3000	3000	2000	
Rated current	Arms	4.2	5.9	5.2	9.3	11.8	12	
Instantaneous max. current	Arms	15	18	16	28	35.5	26.4	
Moment of inertia	No brake	$\times 10^{-4}$ Kg.m ²	2.88	14	12.1	20.2	26	12.7
	With brake	$\times 10^{-4}$ Kg.m ²	3	15.2	13.3	21.4	27.2	14.2
Torque constant	N.m/A	1.135	0.918	1.83	0.895	0.964	1.27	
Induced voltage constant per phase	mV[r/min]	43.3	33.65	67.3	34.84	40.18	83.08	
Rated power rate	No brake	KW/S	79	63.29	75.4	33.9	50.87	177
	With brake	KW/S	75.84	58.26	68.6	32	48.6	158
Mechanical time constant	No brake	ms	1.01	3.43	1.12	2.57	2.06	0.583
	With brake	ms	1.05	3.72	1.23	2.72	2.15	0.651
Electrical time constant	ms	5.1	11.1	9.65	14.63	15.99	9.58	
Phase q-axis/d-axis inductance	mH	8.4/5.7	8.4/4.3	11/8.7	5.8/2.9	4.9/2.6	-	
Weight: No brake[with brake]	kg	3.46 [4.14]	5.53 [7.13]	6.91 [8.51]	6.89 [8.49]	8.14 [9.74]	11.4[13]	
Permissible load	Radial load	N	392	490	490	490	490	
	Axial load	N	147	160	160	160	196	
Brake specification	Rated voltage	V	DC24V \pm 10%					
	Rated current	A	0.42	0.9	0.9	0.9	0.96	
	Brake power	w	10	22	22	22	23	
	Static friction torque	N.m	3.8 or more	14 or more	14 or more	14 or more	14 or more	20 or more
Note: Holding brake	Suction time	ms	70 or less	100 or less	100 or less	100 or less	100 or less	80 or less
	Release time	ms	20 or less	60 or less	60 or less	60 or less	60 or less	40 or less
	Release voltage	ms	DC1V or more					DC0.5V or more

Torque characteristics

Instantaneous operation range Continuous operation range

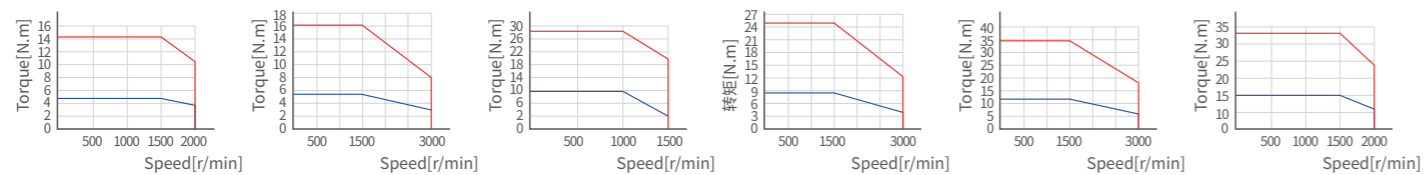

X2MG075A ▲ X2MG085A ▲ X2MG100A ▲ X2MG130A ▲ X2MG180A ▲ X2MG230A ▲

External Dimensions for Servo Motor

Unit(mm)

Models	X2MG075A(Lead-wire type)	X2MG085A	X2MG100A	X2MG130A	X2MG180A	X2MG230A
LC	80	130	130	130	130	130
LA	ϕ 90	ϕ 145	ϕ 145	ϕ 145	ϕ 145	ϕ 145
LB	ϕ 70	ϕ 110	ϕ 110	ϕ 110	ϕ 110	ϕ 110
LZ	4- ϕ 6.6	4- ϕ 9	4- ϕ 9	4- ϕ 9	4- ϕ 9	4- ϕ 9
LR	35	55	55	55	55	55
S	ϕ 19 h6	ϕ 22 h6	ϕ 22 h6	ϕ 22 h6	ϕ 22 h6	ϕ 22 h6
LL no brake [with brake]	134 [177]	135.5 [155.5]	135.5 [155.5]	149.5 [169.5]	163.5 [183.5]	198 [223]
LN no brake [with brake]	—	108 [128]	108 [128]	122 [142]	136 [156]	167 [192]
LG	8	12	12	12	12	12
LE	3	6	6	6	6	6
LM1 no brake [with brake]	—	123.5 [143.5]	123.5 [143.5]	137.5 [157.5]	151.5 [171.5]	186 [211]
LM2 no brake [with brake]	—	—	—	—	—	—[173]
LM3	—	69	69	83	97	127.6
LH1	54	115	115	115	115	118
LH2	—	—	—	—	—	81.5
LH3	—	56.5	56.5	56.5	56.5	58.5
LK	25	45	45	45	45	45
T	6	7	7	7	7	7
KW	6 h9	8 h9	8 h9	8 h9	8 h9	8 h9
KH	15.5	18	18	18	18	18
TP	M5depth12	M6depth20	M6depth20	M6depth20	M6depth20	M6depth20
H	H-type cable length for lead-wire type	210	—	—	—	—

NOTE *2: For X2 series servo motors, the lead-wire types are needed to be customized. For details, please contact our sales department.

X2MG075A

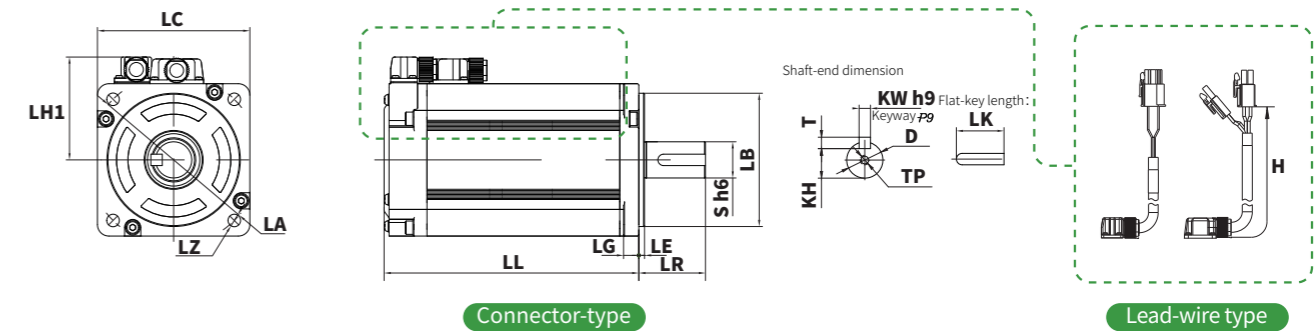

X2MG085A / X2MG100A / X2MG130A / X2MG180A / X2MG230A

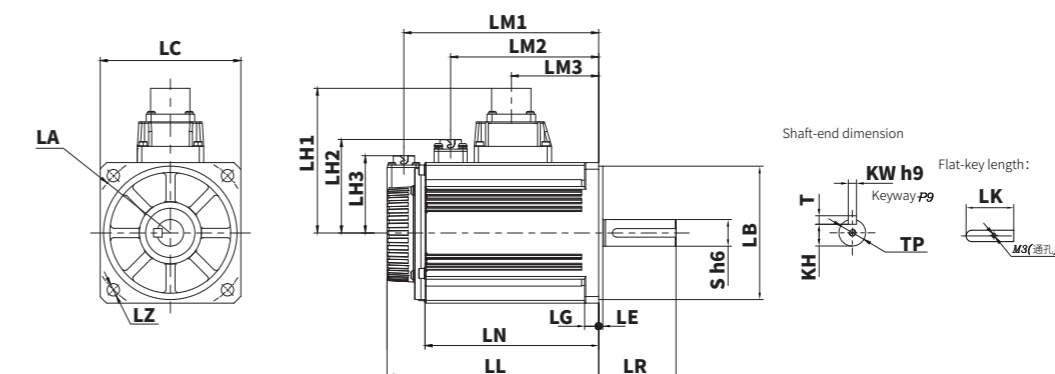

Servo Motor Specifications 800 W 1 KW 1.5 KW 2 KW

Items	Unit	X2MS080A	X2MS100B	X2MS150B	X2MS200B	
Rated power	W	800	1000	1500	2000	
Rated voltage	V	220	220	220	220	
Fitting flange size	mm	60	130	130	130	
Rated torque	N.m	1.27	4.77	7.16	9.55	
Instantaneous max. torque	N.m	3.81	14.31	21.5	28.6	
Rated speed	r/min	6000	2000	2000	2000	
	r/min	10000	5000	5000	5000	
Max. speed						
Rated current	Arms	3.8	8.25	9.5	15	
Instantaneous max. current	Arms	12	25	29	50	
Moment of inertia	No brake	$\times 10^{-4}$ Kg.m ²	1.15	9.16	12.1	16.85
	With brake	$\times 10^{-4}$ Kg.m ²	*1	10.4	13.3	18.05
Torque constant	N.m/A	0.33	0.573	0.672	0.627	
Induced voltage constant per phase	mV[r/min]	12.4	21.2	25.9	23	
Rated power rate	No brake	KW/S	13.9	24.84	42.37	54.13
	With brake	KW/S	*1	21.88	38.55	50.53
Mechanical time constant	No brake	ms	1.09	1.24	1.08	0.93
	With brake	ms	*1	1.41	1.18	1
Electrical time constant	ms	2.88	13.3	16.13	13.75	
Phase q-axis/d-axis inductance	mH	1.12/0.79	2.2/1.1	2.5/1.3	1.1/0.6	
Weight: No brake[with brake]	kg	2.04	5.87 [7.47]	6.98 [8.58]	6.91 [8.51]	
Permissible load	Radial load	N	245	490	490	490
	Axial load	N	98	196	196	196
Brake specification	Rated voltage	V	—	DC24V±10%		
	Rated current	A	—	0.9	0.9	0.9
	Brake power	w	*1	22	22	22
	Static friction torque	N.m	—	14 or more	14 or more	14 or more
Note: Holding brake	Suction time	ms	—	100 or less	100 or less	100 or less
	Release time	ms	—	60 or less	60 or less	60 or less
	Release voltage	ms	—	DC1V or more		

*1: Indicates there is no model with the brake.

Torque characteristics Instantaneous operation range Continuous operation range



X2MS080A ▲ X2MS100B ▲ X2MS150B ▲ X2MS200B ▲

External Dimensions for Servo Motor

Unit(mm)

Models	X2MS080A(Lead-wire type)	X2MS100B	X2MS150B	X2MS200B
LC	60	130	130	130
LA	φ70	φ145	φ145	φ145
LB	φ50	φ110	φ110	φ110
LZ	4-φ5.4	4-φ9	4-φ9	4-φ9
LR	30	55	55	55
S	φ14 h6	φ22 h6	φ22 h6	φ22 h6
LL no brake [with brake]	144.1 [*1]	121.5 [141.5]	135.5 [155.5]	163.5 [183.5]
LN no brake [with brake]	—	94 [114]	108 [128]	136 [156]
LG	6.5	12	12	12
LE	3	6	6	6
LM1 no brake [with brake]	—	109.5 [129.5]	123.5 [143.5]	151.5 [171.5]
LM3	—	55	69	97
LH1	43.5	115	115	115
LH3	—	56.5	56.5	56.5
LK	25	45	45	45
T	5	7	7	7
KW	5 h9	8 h9	8 h9	8 h9
KH	11	18	18	18
TP	M5depth12	M6depth20	M6depth20	M6depth20
H H-type cable length for lead-wire type	210	—	—	—

X2MS080A

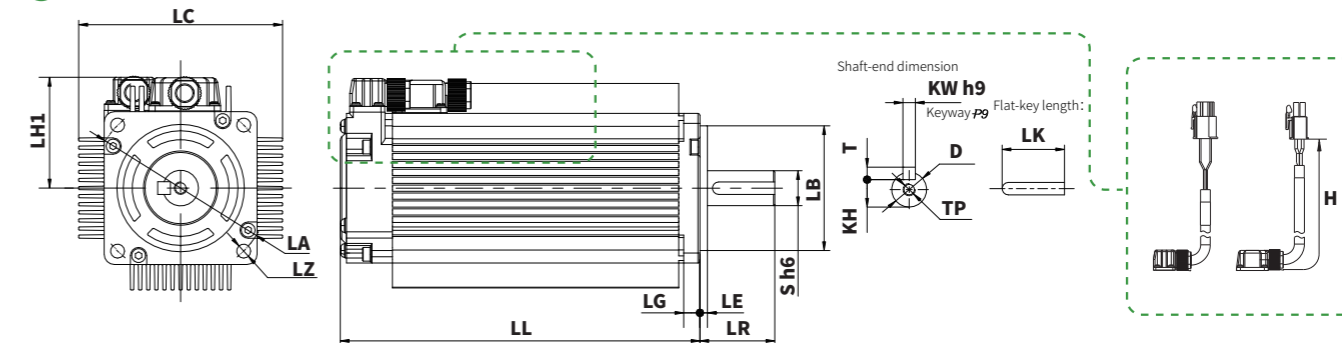

Lead-wire type

X2MS100B / X2MS150B / X2MS200B

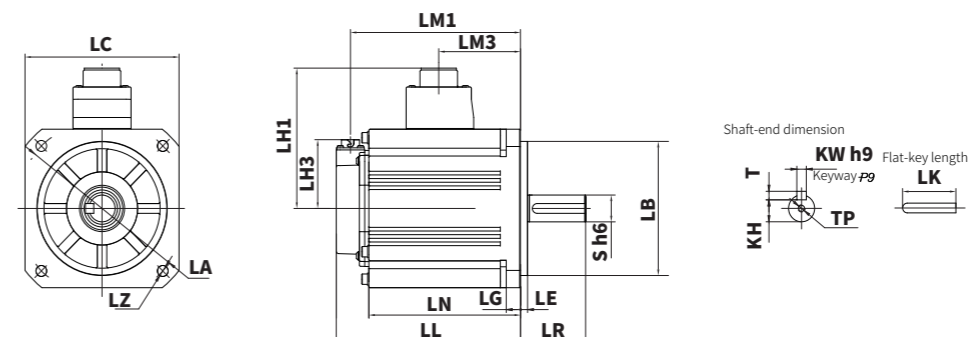

NOTE *1:Indicates that there is no brake model for this model
*2: For X2 series servo motors, the lead-wire types are needed to be customized. For details, please contact our sales department.

	Power	Models	17bit absolute	17bit absolute	Brake	Oil seal	Flange	Shaft diameter	Regular model	Applicable accessories		Power	X3E [] _ _ _ A-A2				X2E [] _ _ _ A-A			Notes
													[A]Pulse control	[N] CANopen	[B] EtherCAT	Power specifications	[A]Pulse control	[N] CANopen	Power specifications	
X2-MA Low-inertia	200W	X2MA020A-N2CA	●		●	●	60 flange	Φ14	Connector-type	① ⑤ ③①	X2-MA Low-inertia	200W	X3EA020A-A2	X3EN020A-A2	X3EB020A-A2	Single-phase AC220V	X2EA020A-A	X2EN020A-A	Single-phase AC220V	Motor futures
		X2MA020A-B2CA		●		●	60 flange	Φ14	Connector-type	① ⑥ ③①										Motor futures
		X2MA020A-N2CN			●				Connector-type	② ⑤										Motor futures
		X2MA020A-B2CN		●		●			Connector-type	② ⑥										Motor futures
	400W	X2MA040A-N2CA	●		●	●	60 flange	Φ14	Connector-type	① ⑤ ③①		400W	X3EA040A-A2	X3EN040A-A2	X3EB040A-A2	Single-phase AC220V	X2EA040A-A	X2EN040A-A	Single-phase AC220V	Motor futures
		X2MA040A-B2CA		●		●	60 flange	Φ14	Connector-type	① ⑥ ③①										Motor futures
		X2MA040A-N2CN			●				Connector-type	② ⑤										Motor futures
		X2MA040A-B2CN		●		●			Connector-type	② ⑥										Motor futures
	750W	X2MA075A-N2CA	●			●	80 flange	Φ19	Connector-type	① ⑤ ③①		750W	X3EA075A-A2	X3EN075A-A2	X3EB075A-A2	Single-phase AC220V	X2EA075A-A	X2EN075A-A	Single-phase AC220V	Motor futures
		X2MA075A-B2CA			●		80 flange	Φ19	Connector-type	① ⑥ ③①										Motor futures
		X2MA075A-N2CN			●				Connector-type	② ⑤										Motor futures
		X2MA075A-B2CN		●		●			Connector-type	② ⑥										Motor futures
1KW	X2MA100A-N2LA	●			●	100 flange	Φ19	Aviation connector	⑪ ⑫ ③①	1KW	X3EA150A-A2	X3EN150A-A2	X3EB150A-A2	Three-phase AC220V	X2EA150A-A	X2EN150A-A	Three-phase AC220V			
	X2MA100A-B2LA			●		100 flange	Φ19	Aviation connector	⑪ ⑫ ⑭ ③①											
	X2MA100A-N2LN			●				Aviation connector	⑪ ⑫											
	X2MA100A-B2LN		●		●			Aviation connector	⑪ ⑫ ⑭											
1.5KW	X2MA150A-N2LA	●			●	100 flange	Φ19	Aviation connector	⑪ ⑫ ③①	1.5KW	X3EA150A-A2	X3EN150A-A2	X3EB150A-A2	Three-phase AC220V	X2EA150A-A	X2EN150A-A	Three-phase AC220V			
	X2MA150A-B2LA			●		100 flange	Φ19	Aviation connector	⑪ ⑫ ⑭ ③①											
	X2MA150A-N2LN			●				Aviation connector	⑪ ⑫											
	X2MA150A-B2LN		●		●			Aviation connector	⑪ ⑫ ⑭											
2KW	X2MA200A-N2LA	●			●	100 flange	Φ19	Aviation connector	⑪ ⑫ ③①	2KW	X3EA200A-A2	X3EN200A-A2	X3EB200A-A2	Three-phase AC220V	X2EA200A-A	X2EN200A-A	Three-phase AC220V			
	X2MA200A-B2LA			●		100 flange	Φ19	Aviation connector	⑪ ⑫ ⑭ ③①											
	X2MA200A-N2LN			●				Aviation connector	⑪ ⑫											
	X2MA200A-B2LN		●		●			Aviation connector	⑪ ⑫ ⑭											
X2-MM Low-inertia	1KW	X2MM100A-N2LA	●			●	130 flange	Φ22	Aviation connector	⑪ ⑫ ③①	X2-MM Middle inertia	1KW	X3EA100A-A2	X3EN100A-A2	X3EB100A-A2	Three-phase AC220V	X2EA100A-A	X2EN100A-A	Three-phase AC220V	
		X2MM100A-B2LA			●		130 flange	Φ22	Aviation connector	⑪ ⑬ ③①										
		X2MM100A-N2LN			●				Aviation connector	⑪ ⑫										
		X2MM100A-B2LN		●		●			Aviation connector	⑪ ⑬										
	1.5KW	X2MM150A-N2LA	●			●	130 flange	Φ22	Aviation connector	⑪ ⑫ ③①		1.5KW	X3EA150A-A2	X3EN150A-A2	X3EB150A-A2	Three-phase AC220V	X2EA150A-A	X2EN150A-A	Three-phase AC220V	
		X2MM150A-B2LA			●		130 flange	Φ22	Aviation connector	⑪ ⑬ ③①										
		X2MM150A-N2LN			●				Aviation connector	⑪ ⑫										
		X2MM150A-B2LN		●		●			Aviation connector	⑪ ⑬										
	2KW	X2MM200A-N2LA	●			●	130 flange	Φ22	Aviation connector	⑪ ⑫ ③①		2KW	X3EA200A-A2	X3EN200A-A2	X3EB200A-A2	Three-phase AC220V	X2EA200A-A	X2EN200A-A	Three-phase AC220V	
		X2MM200A-B2LA			●		130 flange	Φ22	Aviation connector	⑪ ⑬ ③①										
		X2MM200A-N2LN			●				Aviation connector	⑪ ⑫										
		X2MM200A-B2LN		●		●			Aviation connector	⑪ ⑬										

Accessories specifications for connector-type servo motors if flange 40 to 80

- ① SVCAB-ENC075CA-ABS-***L-05 Absolute encoder cable
- ② SVCAB-ENC075CA-***L-05 Incremental encoder cable
- ③ SVCAB-PWR010CA-***L-05 UVW power cable 50W~100W
- ④ SVCAB-PWB010CA-***L-05 UVW power cable with brake 50W~100W
- ⑤ SVCAB-PWR075CA-***L-05 UVW power cable 200W~1KW
- ⑥ SVCAB-PWB075CA-***L-05 UVW power cable with brake 200W~1KW

Aviation connector specifications for servo motor of flange 100&130&180

- ⑪ ENC-TE 1KW Encoder accessories (10-pin aviation connector + 1394 connector)
- ⑫ PWR-CON 1KW 4-core power aviation connector, for flange 100&130
- ⑬ PWR-CON 1KW-9P 9-pin brake power aviation connector, for flange 100&130
- ⑭ PWB-CON- 1KW 2-core brake power connector *1
- ⑮ PWR-CON 7.5KW 4-core power aviation connector, for flange 180

*1 For flange 130 models, only X2MA100A/150A/200A/X2MG230A and 180 flange models require PWB-CON- 1KW

Accessories specifications for lead-wire type servo motor of flange 40 to 80

- ⑰ ENC-TE 750W 2 packs of encoder accessories (6-hole plastic connector + 1394 connector)
- ⑱ PWR-CON 750W 4-hole power plastic connector
- ⑲ PWB-CON 750W 6-hole power brake plastic connector

Other accessories specifications

- ⑳ SV-BAT Absolute battery box with 1394 connector



	Power	Models	17bit absolute	17bit absolute	Brake	Oil seal	Flange	Shaft diameter	Regular model	Applicable accessories		Power	X3E [] _ _ _ A-A2				X2E [] _ _ _ A-A			Notes
													[A]Pulse control	[N] CANopen	[B] EtherCAT	Power specifications	[A]Pulse control	[N] CANopen	Power specifications	
X2-MH high inertia	50W	X2MH005A-N2CA	●		●	●	40 flange	Φ8	Connector-type	① ③ ③1		50W	X3EA010A-A2	X3EN010A-A2	X3EB010A-A2	Single-phase AC220V	X2EA010A-A	X2EN010A-A	Single-phase AC220V	
		X2MH005A-B2CA		●					① ④ ③1											
		X2MH005A-N2CN			●				② ③											
	100W	X2MH005A-B2CN		●	●				② ④											
		X2MH010A-N2CA	●			●	40 flange	Φ8	Connector-type	① ③ ③1		100W	X3EA010A-A2	X3EN010A-A2	X3EB010A-A2	Single-phase AC220V	X2EA010A-A	X2EN010A-A	Single-phase AC220V	
		X2MH010A-B2CA		●					① ④ ③1											
	X2MH010A-N2CN			●				② ③												
	150W	X2MH010A-B2CN			●				② ④											
		X2MH015A-N2CA	●			●	40 flange	Φ8	Connector-type	① ③ ③1		150W	X3EA020A-A2	X3EN020A-A2	X3EB020A-A2	Single-phase AC220V	X2EA020A-A	X2EN020A-A	Single-phase AC220V	
		X2MH015A-B2CA		●					① ④ ③1											
	X2MH015A-N2CN			●				② ③												
	200W	X2MH015A-B2CN			●				② ④											
		X2MH020A-N2CA	●			●	60 flange	Φ14	Connector-type	① ⑤ ③1		200W	X3EA020A-A2	X3EN020A-A2	X3EB020A-A2	Single-phase AC220V	X2EA020A-A	X2EN020A-A	Single-phase AC220V	
		X2MH020A-B2CA		●					① ⑥ ③1											
	X2MH020A-N2CN			●				② ⑤												
	400W	X2MH020A-B2CN			●				② ⑥											
		X2MH040A-N2CA	●			●	60 flange	Φ14	Connector-type	① ⑤ ③1		400W	X3EA040A-A2	X3EN040A-A2	X3EB040A-A2	Single-phase AC220V	X2EA040A-A	X2EN040A-A	Single-phase AC220V	
		X2MH040A-B2CA		●					① ⑥ ③1											
	X2MH040A-N2CN			●				② ⑤												
	750W	X2MH040A-B2CN			●				② ⑥											
		X2MH075A-N2CA	●			●	80 flange	Φ19	Connector-type	① ⑤ ③1		750W	X3EA075A-A2	X3EN075A-A2	X3EB075A-A2	Single-phase AC220V	X2EA075A-A	X2EN075A-A	Single-phase AC220V	
		X2MH075A-B2CA		●					① ⑥ ③1											
	X2MH075A-N2CN			●				② ⑤												
	1KW	X2MH075A-B2CN			●				② ⑥											
X2MH100A-N2LA		●			●	130 flange	Φ22	Aviation connector	⑪ ⑫ ③1		1KW	X3EA100A-A2	X3EN100A-A2	X3EB100A-A2	Three-phase AC220V	X2EA100A-A	X2EN100A-A	Single-phase AC220V		
X2MH100A-B2LA			●					⑪ ⑬ ③1												
X2MH100A-N2LN			●				⑪ ⑫													
1.5KW	X2MH100A-B2LN			●				⑪ ⑬												
	X2MH150A-N2LA	●			●	130 flange	Φ22	Aviation connector	⑪ ⑫ ③1		1.5KW	X3EA150A-A2	X3EN150A-A2	X3EB150A-A2	Three-phase AC220V	X2EA150A-A	X2EN150A-A	Three-phase AC220V		
	X2MH150A-B2LA		●					⑪ ⑬ ③1												
	X2MH150A-N2LN			●				⑪ ⑫												
X2MH150A-B2LN			●				⑪ ⑬													

Accessories specifications for connector-type servo motors if flange 40 to 80

- ① SVCAB-ENC075CA-ABS-***L-05 Absolute encoder cable
- ② SVCAB-ENC075CA-***L-05 Incremental encoder cable
- ③ SVCAB-PWR010CA-***L-05 UVW power cable 50W~100W
- ④ SVCAB-PWB010CA-***L-05 UVW power cable with brake 50W~100W
- ⑤ SVCAB-PWR075CA-***L-05 UVW power cable 200W~1KW
- ⑥ SVCAB-PWB075CA-***L-05 UVW power cable with brake 200W~1KW

Aviation connector specifications for servo motor of flange 100&130&180

- ⑪ ENC-TE 1KW Encoder accessories (10-pin aviation connector + 1394 connector)
 - ⑫ PWR-CON 1KW 4-core power aviation connector, for flange 100&130
 - ⑬ PWR-CON 1KW-9P 9-pin brake power aviation connector, for flange 100&130
 - ⑭ PWB-CON- 1KW 2-core brake power connector *1
 - ⑮ PWR-CON 7.5KW 4-core power aviation connector, for flange 180
- *1 For flange 130 models, only X2MA100A/150A/200A/X2MG230A and 180 flange models require PWB-CON- 1KW

Accessories specifications for lead-wire type servo motor of flange 40 to 80

- ⑳ ENC-TE 750W 2 packs of encoder accessories (6-hole plastic connector + 1394 connector)
- ㉑ PWR-CON 750W 4-hole power plastic connector
- ㉒ PWB-CON 750W 6-hole power brake plastic connector

Other accessories specifications

- ㉓ SV-BAT Absolute battery box with 1394 connector



	Power	Models	17bit absolute	17bit absolute	Brake	Oil seal	Flange	Shaft diameter	Regular model	Applicable accessories		Power	X3E [] _ _ _ A-A2				X2E [] _ _ _ A-A			Notes
													[A]Pulse control	[N] CANopen	[B] EtherCAT	Power specifications	[A]Pulse control	[N] CANopen	Power specifications	
X2-MHH Ultrahigh inertia	100W	X2MH010H-N2CA	●		●	●	40 flange	Φ8	Connector-type	① ③ ③①	X2-MHH Ultrahigh inertia	100W	X3EA010A-A2	X3EN010A-A2	X3EB010A-A2	Single-phase AC220V	X2EA010A-A	X2EN010A-A	Single-phase AC220V	
		X2MH010H-B2CA			●				① ④ ③①											
		X2MH010H-N2CN		●					② ③											
		X2MH010H-B2CN			●				② ④											
	200W	X2MH020H-N2LA	●			●	60 flange	Φ14	Lead-wire type	②① ②② ③①		200W	X3EA020A-A2	X3EN020A-A2	X3EB020A-A2	Single-phase AC220V	X2EA020A-A	X2EN020A-A	Single-phase AC220V	
		X2MH020H-B2LA			●				②① ②③ ③①											
		X2MH020H-N2LN		●					②① ②②											
		X2MH020H-B2LN			●				②① ②③											
	400W	X2MH040H-N2CA	●			●	60 flange	Φ14	Connector-type	① ⑤ ③①		400W	X3EA040A-A2	X3EN040A-A2	X3EB040A-A2	Single-phase AC220V	X2EA040A-A	X2EN040A-A	Single-phase AC220V	
		X2MH040H-B2CA			●				① ⑥ ③①											
		X2MH040H-N2CN		●					② ⑤											
		X2MH040H-B2CN			●				② ⑥											
750W	X2MH075H-N2LA	●			●	80 flange	Φ19	Lead-wire type	②① ②② ③①	750W	X3EA075A-A2	X3EN075A-A2	X3EB075A-A2	Single-phase AC220V	X2EA075A-A	X2EN075A-A	Single-phase AC220V			
	X2MH075H-B2LA			●				②① ②③ ③①												
	X2MH075H-N2LN		●					②① ②②												
	X2MH075H-B2LN			●				②① ②③												
X2-MQ Special flange/Flat-type/small flange	100W	X2MQ010A-N2LA	●		●	●	60 flange	Φ8	Lead-wire type	②① ②② ③①	X2-MQ Special flange/Flat-type/small flange	100W	X3EA010A-A2	X3EN010A-A2	X3EB010A-A2	Single-phase AC220V	X2EA010A-A	X2EN010A-A	Single-phase AC220V	
		X2MQ010A-B2LA			●				②① ②③ ③①											
	200W	X2MQ020A-N2LA	●			●	●	80 flange	Φ11	Lead-wire type		②① ②② ③①	200W	X3EA020A-A2	X3EN020A-A2	X3EB020A-A2	Single-phase AC220V	X2EA020A-A	X2EN020A-A	Single-phase AC220V
		X2MQ020A-B2LA			●				②① ②③ ③①											
	400W	X2MQ040A-N2LA	●			●	●	80 flange	Φ14	Lead-wire type		②① ②② ③①	400W	X3EA040A-A2	X3EN040A-A2	X3EB040A-A2	Single-phase AC220V	X2EA040A-A	X2EN040A-A	Single-phase AC220V
		X2MQ040A-B2LA			●				②① ②③ ③①											
	1KW	X2MQ100E-N2CA	●			●	●	80 flange	Φ19	Connector-type		① ⑤ ③①	1KW	X3EA100A-A2	X3EN100A-A2	X3EB100A-A2	Three-phase AC220V	X2EA100A-A	X2EN100A-A	Three-phase AC220V
		X2MQ100E-B2CA			●				① ⑥ ③①											
		X2MQ100E-N2CN		●					② ⑤											
		X2MQ100E-B2CN			●				② ⑥											

Accessories specifications for connector-type servo motors if flange 40 to 80

- ① SVCAB-ENC075CA-ABS-***L-05 Absolute encoder cable
- ② SVCAB-ENC075CA-***L-05 Incremental encoder cable
- ③ SVCAB-PWR010CA-***L-05 UVW power cable 50W~100W
- ④ SVCAB-PWB010CA-***L-05 UVW power cable with brake 50W~100W
- ⑤ SVCAB-PWR075CA-***L-05 UVW power cable 200W~1KW
- ⑥ SVCAB-PWB075CA-***L-05 UVW power cable with brake 200W~1KW

Aviation connector specifications for servo motor of flange 100&130&180

- ⑪ ENC-TE 1KW Encoder accessories (10-pin aviation connector + 1394 connector)
 - ⑫ PWR-CON 1KW 4-core power aviation connector, for flange 100&130
 - ⑬ PWR-CON 1KW-9P 9-pin brake power aviation connector, for flange 100&130
 - ⑭ PWB-CON- 1KW 2-core brake power connector *1
 - ⑮ PWR-CON 7.5KW 4-core power aviation connector, for flange 180
- *1 For flange 130 models, only X2MA100A/150A/200A/X2MG230A and 180 flange models require PWB-CON- 1KW

Accessories specifications for lead-wire type servo motor of flange 40 to 80

- ⑲ ENC-TE 750W 2 packs of encoder accessories (6-hole plastic connector + 1394 connector)
- ⑳ PWR-CON 750W 4-hole power plastic connector
- ㉓ PWB-CON 750W 6-hole power brake plastic connector

Other accessories specifications

- ③① SV-BAT Absolute battery box with 1394 connector



	Power	Models	17bit absolute	17bit absolute	Brake	Oil seal	Flange	Shaft diameter	Regular model	Applicable accessories		Power	X3E [] _ _ _ A-A2				X2E [] _ _ _ A-A			Notes
													[A]Pulse control	[N] CANopen	[B] EtherCAT	Power specifications	[A]Pulse control	[N] CANopen	Power specifications	
X2-MG Low-speed and Large-torque	750W	X2MG075A-N2LA	●				80 flange	Φ19	Lead-wire type	21 22 31	X2-MG Low-speed and Large-torque	750W	X3EA075A-A2	X3EN075A-A2	X3EB075A-A2	Single-phase AC220V	X2EA075A-A	X2EN075A-A	Single-phase AC220V	
		X2MG075A-B2LA		●					21 23 31											
		X2MG075A-N2LN			●					21 22										
		X2MG075A-B2LN			●					21 23										
	1KW	X2MG100A-N2LA	●						Aviation connector	11 12 31		1KW	X3EA100A-A2	X3EN100A-A2	X3EB100A-A2	Three-phase AC220V	X2EA100A-A	X2EN100A-A	Single-phase AC220V	
		X2MG100A-B2LA		●						11 13 31										
		X2MG100A-N2LN			●					11 12										
		X2MG100A-B2LN			●					11 13										
	850W	X2MG085A-N2LA	●						Aviation connector	11 12 31		850W	X3EA100A-A2	X3EN100A-A2	X3EB100A-A2	Single-phase AC220V	X2EA100A-A	X2EN100A-A	Single-phase AC220V	
		X2MG085A-B2LA		●						11 13 31										
		X2MG085A-N2LN			●					11 12										
		X2MG085A-B2LN			●					11 13										
	1.3KW	X2MG130A-N2LA	●						Aviation connector	11 12 31		1.3KW	X3EA150A-A2	X3EN150A-A2	X3EB150A-A2	Three-phase AC220V	X2EA150A-A	X2EN150A-A	Three-phase AC220V	
		X2MG130A-B2LA		●						11 13 31										
		X2MG130A-N2LN			●					11 12										
		X2MG130A-B2LN			●					11 13										
1.8KW	X2MG180A-N2LA	●						Aviation connector	11 12 31	1.8KW	X3EA200A-A2	X3EN200A-A2	X3EB200A-A2	Three-phase AC220V	X2EA200A-A	X2EN200A-A	Three-phase AC220V			
	X2MG180A-B2LA		●						11 13 31											
	X2MG180A-N2LN			●					11 12											
	X2MG180A-B2LN			●					11 13											
2.3KW	X2MG230A-N2LA	●						Aviation connector	11 12 31	2.3KW	X3EA250A-A2	X3EN250A-A2	X3EB250A-A2	Three-phase AC220V	X2EA250A-A	X2EN250A-A	Three-phase AC220V			
	X2MG230A-B2LA		●						11 12 14 31											
	X2MG230A-N2LN			●					11 12											
	X2MG230A-B2LN			●					11 12 14											
X2-MS Ultrahigh Inertia	800W	X2MS080A-N2LN		●			60 flange	Φ14	Lead-wire type	21 22	X2-MS Ultrahigh Inertia	800W	X3EA075A-A2	X3EN075A-A2	X3EB075A-A2	Single-phase AC220V	X2EA075A-A	X2EN075A-A	Single-phase AC220V	
	1KW	X2MS100B-N2LA	●						Aviation connector	11 12 31		1KW	X3EA100A-A2	X3EN100A-A2	X3EB100A-A2	Three-phase AC220V	X2EA100A-A	X2EN100A-A	Single-phase AC220V	
		X2MS100B-B2LA		●						11 13 31										
		X2MS100B-N2LN			●					11 12										
		X2MS100B-B2LN			●					11 13										
	1.5KW	X2MS150B-N2LA	●						Aviation connector	11 12 31		1.5KW	X3EA150A-A2	X3EN150A-A2	X3EB150A-A2	Three-phase AC220V	X2EA150A-A	X2EN150A-A	Three-phase AC220V	
		X2MS150B-B2LA		●						11 13 31										
		X2MS150B-N2LN			●					11 12										
		X2MS150B-B2LN			●					11 13										
	2KW	X2MS200B-N2LA	●						Aviation connector	11 12 31		2KW	X3EA200A-A2	X3EN200A-A2	X3EB200A-A2	Three-phase AC220V	X2EA200A-A	X2EN200A-A	Three-phase AC220V	
		X2MS200B-B2LA		●						11 13 31										
X2MS200B-N2LN				●					11 12											
X2MS200B-B2LN				●					11 13											

Accessories specifications for connector-type servo motors if flange 40 to 80

- 1 SVCAB-ENC075CA-ABS-***L-05 Absolute encoder cable
- 2 SVCAB-ENC075CA-***L-05 Incremental encoder cable
- 3 SVCAB-PWR010CA-***L-05 UVW power cable 50W~100W
- 4 SVCAB-PWB010CA-***L-05 UVW power cable with brake 50W~100W
- 5 SVCAB-PWR075CA-***L-05 UVW power cable 200W~1KW
- 6 SVCAB-PWB075CA-***L-05 UVW power cable with brake 200W~1KW

Aviation connector specifications for servo motor of flange 100&130&180

- 11 ENC-TE 1KW Encoder accessories (10-pin aviation connector + 1394 connector)
 - 12 PWR-CON 1KW 4-core power aviation connector, for flange 100&130
 - 13 PWR-CON 1KW-9P 9-pin brake power aviation connector, for flange 100&130
 - 14 PWB-CON- 1KW 2-core brake power connector *1
 - 15 PWR-CON 7.5KW 4-core power aviation connector, for flange 180
- *1 For flange 130 models, only X2MA100A/150A/200A/X2MG230A and 180 flange models require PWB-CON- 1KW

Accessories specifications for lead-wire type servo motor of flange 40 to 80

- 21 ENC-TE 750W 2 packs of encoder accessories (6-hole plastic connector + 1394 connector)
- 22 PWR-CON 750W 4-hole power plastic connector
- 23 PWB-CON 750W 6-hole power brake plastic connector

Other accessories specifications

- 31 SV-BAT Absolute battery box with 1394 connector
- 

Naming Rule for X6 Series Servo Motor

SV-X6 MA 040 A - N 2 C D - ****

1 2 3 4 5 6 7 8 Special specifications

1 Product Series	
SV-X6 Series	17BIT/23BIT

2 Inertia Specifications	
MA	Low Inertia
MM	Medium Inertia
MH	High Inertia
MHH	Ultra-high Inertia
MQ	Special flange/Flat-type/small flange
MG	Low-speed & high-torque
MGS	Low cogging cutting

3 Power Specification			
005	50W	180	1.8KW
010	100W	200	2KW
015	150W	240	2.4KW
020	200W	290	2.9KW
040	400W	300	3KW
075	750W	400	4KW
085	850W	440	4.4KW
100	1KW	500	5KW
130	1.3KW	550	5.5KW
150	1.5KW	750	7.5KW

4 Design No.	
A/B/C/E/F/H/K/S	

5 Brake Specification	
N	No brake
B	With brake

6 Power Voltage Specification	
2	AC220V

7 Specification	
K	Key shaft/no oil seal
L	Key shaft/oil seal
C	Connector type/key shaft/with oil seal*1
D	Connector type/key shaft/no oil seal*1
J	Compact (ccustomized)

8 Encoder Specifications	
D	Multi-turn 23bit absolute
A	Multi-turn 17bit absolute

9 Customization	
**	N/A

E.g. 23bit absolute 220v 850W MG High torque at low speed naming rule SV-X6 MG 085A-N2LD
 23bit absolute 380v 850W MG High torque at low speed naming rule SV-X6 MG 085A-N4LD
 17bit absolute 380v 850W MG High torque at low speed naming rule SV-X6 MG 085A-N4LA

NOTE *1: From the 2nd quarter of 2021, our company started releasing connector-type servo motor with 40-80 flanges as the regular model.
 Lead-wire servo motors will be discontinued from December 2021, if still needed, the customized application process is required.
 For details, refer to page 67 or consult our sales staff.



X6 Series Servo Motor

Series	Specification	50W	100W	150W	200W	400W	750W	1.0KW	1.5KW	2.0KW	3.0KW	4.0KW	5.0KW	7.5KW	
X6-MA Low Inert	Type	X6MA005A X6MA010A X6MA015A X6MA020A X6MA040A X6MA075A X6MA100A X6MA150A X6MA200A													
	Flanges														
	Rated (peak torque) Inertia (no brakes) (brakes) Rotational speed: rated (max speed) 220V mot 380V mot	0.64 [1.91] 0.16 [0.17] 3000 [6000] 0.64 [1.91] 0.16 [0.17] 3000 [6000] 1.27 [3.82] 0.28 [0.29] 3000 [6000] 2.39 [7.16] 0.96 [1.07] 3000 [6000] 3.18 [9.55] 2.03 [2.35] 3000 [5000] 4.77 [14.3] 2.84 [3.17] 3000 [5000] 9.55 [28.6] 12.1 [13.3] 2000 [3000] 14.3 [42.9] 43.5 [63.2] 2000 [3000] 19.1 [57.3] 54.7 [68] 2000 [3000] 23.9 [71.6] 66.7 [80.8] 2000 [3000] 47.8 [119.4] 136.4 [150.8] 1500 [3000]													
X6-MM Medium Inertia	Type	X6MM005A X6MM010A X6MM015A X6MM020A X6MM040A X6MM075A X6MM100A X6MM150A X6MM200A X6MM300A X6MM400A X6MM500A X6MM750H													
	Flanges														
	Rated (peak torque) Inertia (no brakes) (brakes) Rotational speed: rated (max speed) 220V motor 380V mot	0.32 [1.11] 0.071 [0.074] 3000 [6500] 0.32 [1.11] 0.071 [0.074] 3000 [6500] 0.47 [1.43] 0.13 [0.133] 3000 [6000] 0.47 [1.43] 0.13 [0.133] 3000 [6000] 0.64 [2.23] 0.29 [0.31] 3000 [6500] 0.64 [2.23] 0.29 [0.31] 3000 [6500] 1.27 [4.46] 0.56 [0.58] 3000 [6500] 2.39 [8.36] 1.56 [1.66] 3000 [6000] 4.77 [14.3] 30.8 [32] 2000 [3000] 7.16 [21.5] 9.16 [10.4] 2000 [3000] 9.16 [10.4] 12.1 [13.3] 2000 [3000] 14.3 [42.9] 43.5 [63.2] 2000 [3000] 19.1 [57.3] 54.7 [68] 2000 [3000] 23.9 [71.6] 66.7 [80.8] 2000 [3000] 47.8 [119.4] 136.4 [150.8] 1500 [3000]													
X6-MH High Inertia	Type	X6MH005A X6MH010A X6MH015A X6MH020A X6MH040A X6MH075A X6MH100A X6MH150A X6MH200A X6MH300A X6MH400A X6MH500A X6MH750H													
	Flanges														
	Rated (peak torque) Inertia (no brakes) (brakes) Rotational speed: rated (max speed) 220V motor 380V mot	0.32 [1.11] 0.092 [0.095] 3000 [6500] 0.32 [1.11] 0.092 [0.095] 3000 [6500] 0.47 [1.49] 0.73 [0.75] 3000 [6500] 0.64 [2.23] 0.47 [0.49] 3000 [6500] 0.64 [2.23] 0.47 [0.49] 3000 [6500] 1.27 [4.46] 0.73 [0.75] 3000 [6500] 2.39 [8.36] 3.15 [-*3] 3000 [6000] 4.77 [14.3] 38.5 [39.7] 2000 [3000] 7.16 [21.5] 9.55 [28.6] 2000 [3000] 9.55 [28.6] 19.1 [57.3] 101.7 [115] 2000 [3000]													
X6-MH Ultra-high Inertia	Type	X6MH010H X6MH020H X6MH040H X6MH075H X6MQ010A X6MQ020A X6MQ040A X6MQ100E													
	Flanges														
	Rated (peak torque) Inertia (no brakes) (brakes) Rotational speed: rated (max speed) 220V motor	0.32 [1.11] 0.092 [0.095] 3000 [6500] 0.32 [1.11] 0.092 [0.095] 3000 [6500] 0.637 [1.91] 0.47 [0.5] 3000 [6500] 0.637 [1.91] 0.47 [0.5] 3000 [6500] 1.27 [3.82] 0.87 [0.9] 3000 [6500] 1.27 [3.82] 0.87 [0.9] 3000 [6500] 3.185 [11.13] 2 [2.1] 3000 [6000]													
X6-MQ special flanges flat small fl	Type	X6MQ010A X6MQ020A X6MQ040A X6MQ100E													
	Flanges														
	Rated (peak torque) Inertia (no brakes) (brakes) Rotational speed: rated (max speed) 220V motor	0.32 [0.96] 0.16 [0.18] 3000 [6500] 0.32 [0.96] 0.16 [0.18] 3000 [6500] 0.637 [1.91] 0.47 [0.5] 3000 [6500] 0.637 [1.91] 0.47 [0.5] 3000 [6500] 1.27 [3.82] 0.87 [0.9] 3000 [6500] 1.27 [3.82] 0.87 [0.9] 3000 [6500] 3.185 [11.13] 2 [2.1] 3000 [6000]													
X6-MG Low-speed & high-torque	Type	X6MG075A X6MG100A X6MG150A X6MG200A X6MG240A X6MG290A X6MG440A X6MG550A													
	Flanges														
	Rated (peak torque) Inertia (no brakes) (brakes) Rotational speed: rated (max speed) 220V motor 380V mot	4.77 [14.3] 2.88 [3] 1500 [2000] 4.77 [14.3] 2.88 [3] 1500 [2000] 5.41 [16.2] 14 [15.2] 1500 [3000] 5.41 [16.2] 14 [15.2] 1500 [3000] 8.28 [24.84] 20.2 [21.4] 1500 [3000] 8.28 [24.84] 20.2 [21.4] 1500 [3000] 11.5 [34.5] 26 [27.2] 1500 [3000] 11.5 [34.5] 26 [27.2] 1500 [3000] 15.2 [45.8] 31.3 [32.5] 1500 [3000] 15.2 [45.8] 31.3 [32.5] 1500 [3000] 18.6 [46.5] 47.2 [62.3] 1500 [3000] 18.6 [46.5] 47.2 [62.3] 1500 [3000] 28.4 [71.1] 68.6 [83.7] 1500 [3000] 28.4 [71.1] 68.6 [83.7] 1500 [3000] 35 [87.5] 91.4 [106.5] 1500 [3000]													
X6-MGS Low cogging cutting s	Type	X6MG085S X6MG130S X6MG180S X6MG290S X6MG440S													
	Flanges														
	Rated (peak torque) Inertia (no brakes) (brakes) Rotational speed: rated (max speed) 220V motor 380V mot	5.39 [16.2] 13.9 [16] 1500 [3000] 5.39 [16.2] 13.9 [16] 1500 [3000] 8.28 [24.84] 19.9 [22] 1500 [3000] 8.28 [24.84] 19.9 [22] 1500 [3000] 11.5 [34.5] 26 [28.1] 1500 [3000] 11.5 [34.5] 26 [28.1] 1500 [3000] 18.6 [55.8] 47.2 [62.3] 1500 [4000] 18.6 [55.8] 47.2 [62.3] 1500 [4000]													

*1: te 17 23 indicates the encoder bits. *2: Under development *3: Indicates there is no model with the brake.
 *4: The maximum speed of the servo motor varies due to the design difference of the servo drive

Servo Motor Specifications



Items	Unit	X6MA020A	X6MA040A	X6MA075A	X6MA100A	X6MA150A	X6MA200A	
Rated power	W	200	400	750	1000	1500	2000	
Rated voltage	V	220	220	220	220	220	220	
Fitting flange size	mm	60	60	80	100	100	100	
Rated torque	N.m	0.64	1.27	2.39	3.18	4.77	6.37	
Instantaneous max. torque	N.m	1.91	3.82	7.16	9.55	14.3	19.1	
Rated speed	r/min	3000	3000	3000	3000	3000	3000	
Max. speed	r/min	6000	6000	6000	5000	5000	5000	
	NOTE	*1	*1	*1				
NOTE *1: The above data is only the theoretical performance of the motor design, so the motor performance may vary according to the different series of servo drives.								
Rated current	Arms	1.7	2.7	4.2	6.6	8.2	11.3	
Instantaneous max. current	Arms	6.5	10.2	17.4	28	35	48	
Moment of inertia	No brake	$\times 10^{-4} \text{Kg.m}^2$	0.16	0.28	0.96	2.03	2.84	3.68
	With brake	$\times 10^{-4} \text{Kg.m}^2$	0.17	0.29	1.07	2.35	3.17	4.01
Torque constant	N.m/A	0.427	0.488	0.583	0.52	0.628	0.607	
Induced voltage constant per phase	mV[r/min]	14.5	17.9	21.33	18.15	21.92	21.247	
Rated power rate	No brake	KW/S	25.6	57.6	59.5	49.82	80.12	110.26
	With brake	KW/S	24.1	55.6	53.4	43.03	71.775	101.19
Mechanical time constant	No brake	ms	0.775	0.561	0.463	0.619	0.507	0.425
	With brake	ms	0.824	0.581	0.516	0.717	0.566	0.463
Electrical time constant	ms	6.3	6.1	12.7	7.22	8.08	9.37	
Phase q-axis/d-axis inductance	mH	19/5.6	10.7/7.5	7.6/4.9	—	—	—	
Weight: No brake[with brake]	kg	0.9 [1.3]	1.28 [1.67]	2.25 [3.01]	3.5 [4.5]	4.4 [5.4]	5.3 [6.3]	
Permissible load	Radial load	N	245	245	392	392	392	
	Axial load	N	98	98	147	147	147	
Brake specification	Rated voltage	V	DC24V \pm 10%					
	Rated current	A	0.36	0.36	0.42	0.81 \pm 10%	0.81 \pm 10%	0.81 \pm 10%
	Brake power	w	9	9	10	20	20	20
	Static friction torque	N.m	1.6 or more	1.6 or more	3.8 or more	7.8 or more	7.8 or more	7.8 or more
	Note: Holding brake	Suction time	ms	50 or less	50 or less	70 or less	50 or less	50 or less
Release time	ms	20 or less	20 or less	20 or less	15 or less	15 or less	15 or less	
Release voltage	ms	DC1V or more						

Torque characteristics



External Dimensions for Servo Motor

Unit(mm)

Models	X6MA020A	X6MA040A	X6MA075A	X6MA100A	X6MA150A	X6MA200A
LC	60	60	80	100	100	100
LA	$\phi 70$	$\phi 70$	$\phi 90$	$\phi 115$	$\phi 115$	$\phi 115$
LB	$\phi 50$	$\phi 50$	$\phi 70$	$\phi 95$	$\phi 95$	$\phi 95$
LZ	4- $\phi 5.4$	4- $\phi 5.4$	4- $\phi 6$	4- $\phi 9$	4- $\phi 9$	4- $\phi 9$
LR	30	30	35	55	55	55
S	$\phi 14 \text{ h6}$	$\phi 14 \text{ h6}$	$\phi 19 \text{ h6}$	$\phi 19 \text{ h6}$	$\phi 19 \text{ h6}$	$\phi 19 \text{ h6}$
LL no brake [with brake]	73.5 [103]	93.2[122.7]	105 [138.5]	123.5 [150.5]	142 [169]	161 [188]
LN no brake [with brake]	—	—	—	96.5 [123.5]	115 [142]	134 [161]
LG	6.5	6.5	8	10	10	10
LE	3	3	3	3	3	3
LM1 no brake [with brake]	—	—	—	111.5 [138.5]	130 [157]	149 [176]
LM2 no brake [with brake]	—	—	—	— [105]	— [123.5]	— [142.5]
LM3	—	—	—	62	80.5	99.5
LH1	44.5	44.5	54.5	103	103	103
LH2	—	—	—	66	66.5	66.5
LH3	—	—	—	55	55	55
LK	25	25	25	42	42	42
T	5	5	6	6	6	6
KW	5 h9	5 h9	6 h9	6 h9	6 h9	6 h9
KH	11	11	15.5	15.5	15.5	15.5
TP	M5depth12	M5depth12	M5depth10	M5depth12	M5depth12	M5depth12
H	H-type cable length for lead-wire type	210	210	210	—	—

X6MA020A / X6MA040A / X6MA075A

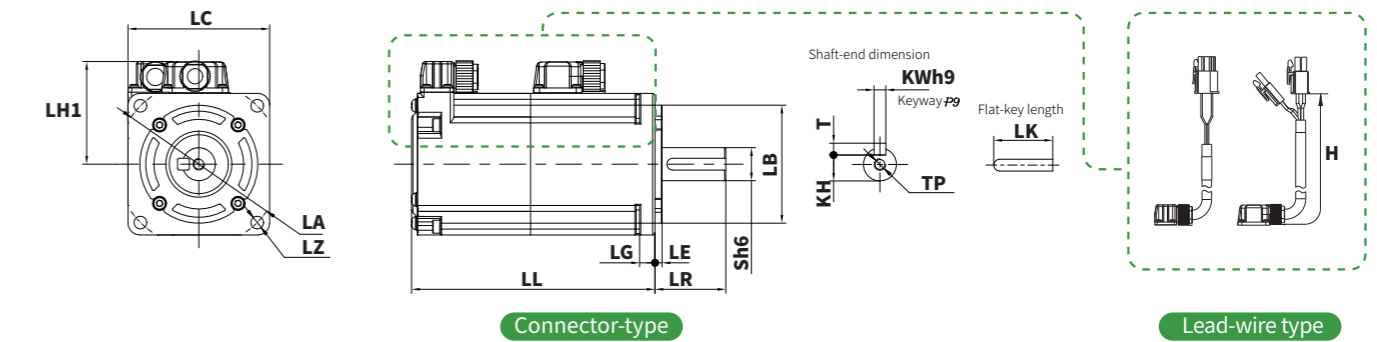

X6MA100A / X6MA150A / X6MA200A

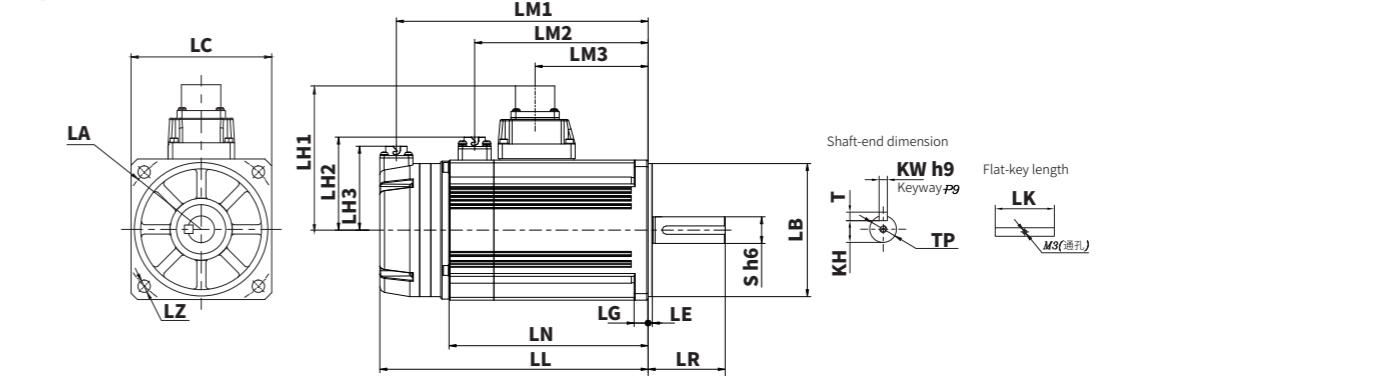

NOTE *2: For X2 series servo motors, the lead-wire types are needed to be customized. For details, please contact our sales department.

Servo Motor Specifications



Items	Unit	X6MM100A	X6MM150A	X6MM200A	
Rated power	W	1000	1500	2000	
Rated voltage	V	220	220	220	
Fitting flange size	mm	130	130	130	
Rated torque	N.m	4.77	7.16	9.55	
Instantaneous max. torque	N.m	14.3	21.5	28.6	
Rated speed	r/min	2000	2000	2000	
Max. speed	r/min	3000	3000	3000	
Rated current	Arms	5.2	8	9.9	
Instantaneous max. current	Arms	15.6	24	30	
Moment of inertia	No brake	$\times 10^{-4} \text{Kg.m}^2$	6.18	9.16	12.1
	With brake	$\times 10^{-4} \text{Kg.m}^2$	7.4	10.4	13.3
Torque constant	N.m/A	0.918	0.895	0.9645	
Induced voltage constant per phase	mV[r/min]	33.65	34.84	37.95	
Rated power rate	No brake	KW/S	36.8	56	75.4
	With brake	KW/S	30.7	49.3	68.6
Mechanical time constant	No brake	ms	1.51	1.16	1.05
	With brake	ms	1.81	1.3	1.16
Electrical time constant	ms	11.1	14.6	15.38	
Phase q-axis/d-axis inductance	mH	8.4/4.3	5.8/2.9	4.9/2.6	
Weight: No brake[with brake]	kg	4.67 [6.27]	5.87 [7.47]	12.1 [13.3]	
Permissible load	Radial load	N	490	490	490
	Axial load	N	196	196	196
Brake specification	Rated voltage	V	DC24V \pm 10%		
	Rated current	A	0.9	0.9	0.9
	Brake power	w	22	22	22
	Static friction torque	N.m	14 or more	14 or more	14 or more
Note: Holding brake	Suction time	ms	100 or less	100 or less	100 or less
	Release time	ms	60 or less	60 or less	60 or less
	Release voltage	ms	DC1V or more		

Torque characteristics

Instantaneous operation range Continuous operation range

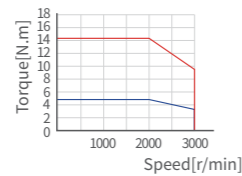

X6MM100A▲



X6MM150A▲

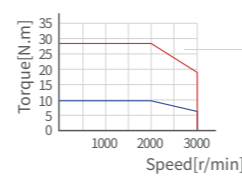

X6MM200A▲

External Dimensions for Servo Motor

Unit(mm)

Models	X6MM100A	X6MM150A	X6MM200A
LC	130	130	130
LA	$\phi 145$	$\phi 145$	$\phi 145$
LB	$\phi 110$	$\phi 110$	$\phi 110$
LZ	4- $\phi 9$	4- $\phi 9$	4- $\phi 9$
LR	55	55	55
S	$\phi 22 \text{ h6}$	$\phi 22 \text{ h6}$	$\phi 22 \text{ h6}$
LL no brake [with brake]	128 [148]	142 [162]	156 [176]
LN no brake [with brake]	80 [100]	94 [114]	108 [128]
LG	12	12	12
LE	6	6	6
LM1 no brake [with brake]	116.2 [136.2]	130.2 [150.2]	144.2 [164.2]
LM3	41	55	69
LH1	115	115	115
LH3	60	60	60
LK	45	45	45
T	7	7	7
KW	8 h9	8 h9	8 h9
KH	18	18	18
TP	M6depth20	M6depth20	M6depth20

X6MM100A / X6MM150A / X6MM200A

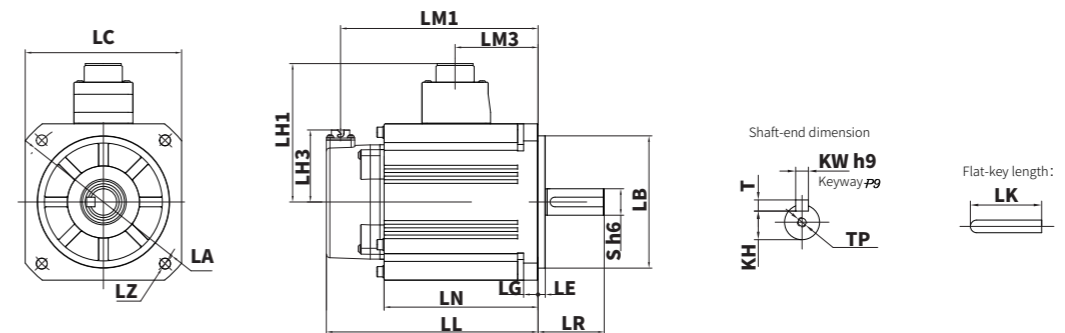

Servo Motor Specifications

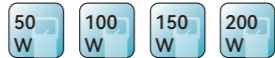

Items	Unit	X6MH005A	X6MH010A	X6MH015A	X6MH020A	
Rated power	W	50	100	150	200	
Rated voltage	V	220	220	220	220	
Fitting flange size	mm	40	40	40	60	
Rated torque	N.m	0.16	0.32	0.477	0.64	
Instantaneous max. torque	N.m	0.56	1.11	1.43	2.23	
Rated speed	r/min	3000	3000	3000	3000	
Max. speed	r/min	6500	6500	6000	6500	
	NOTE				*1	
NOTE *1: The above data is only the theoretical performance of the motor design, so the motor performance may vary according to the different series of servo drives.						
Rated current	Arms	1.1	1.1	1.5	1.4	
Instantaneous max. current	Arms	3.89	3.89	4.5	4.87	
Moment of inertia	No brake	$\times 10^{-4} \text{Kg.m}^2$	0.038	0.071	0.13	0.29
	With brake	$\times 10^{-4} \text{Kg.m}^2$	0.042	0.074	0.133	0.31
Torque constant	N.m/A	0.168	0.327	0.33	0.5	
Induced voltage constant per phase	mV[r/min]	5	11.1	12.2	14.61	
Rated power rate	No brake	KW/S	6.7	14.4	17.5	14.1
	With brake	KW/S	6.1	13.8	17.1	13.2
Mechanical time constant	No brake	ms	2.6	1.67	1.9	1.57
	With brake	ms	2.85	1.74	1.94	1.68
Electrical time constant	ms	0.89	1.1	1.22	2.58	
Phase q-axis/d-axis inductance	mH	5.1/3.4	9.4/6.3	7.2/4.8	10.2/5.8	
Weight: No brake[with brake]	kg	0.33 [0.55]	0.45 [0.66]	0.83 [0.69]	0.87 [1.27]	
Permissible load	Radial load	N	68	68	68	245
	Axial load	N	58	58	58	98
Brake specification	Rated voltage	V	DC24V \pm 10%			
	Rated current	A	0.25	0.25	0.375	0.36
	Brake power	w	6	6	9	9
	Static friction torque	N.m	0.38 or more	0.38 or more	0.58 or more	1.6 or more
Note: Holding brake	Suction time	ms	35 or less	35 or less	50 or less	50 or less
	Release time	ms	20 or less	20 or less	20 or less	20 or less
	Release voltage	ms	DC1V or more			

Torque characteristics

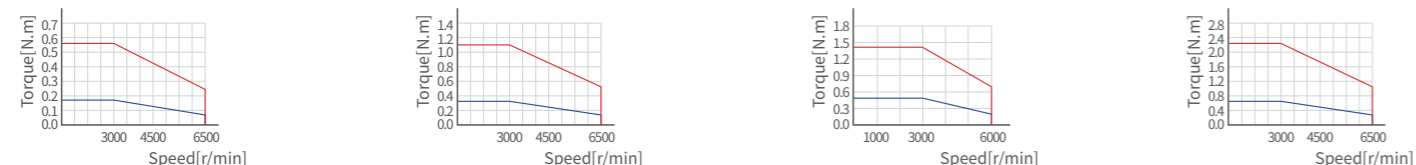

X6MH005A ▲ X6MH010A ▲ X6MH015A ▲ X6MH020A ▲

External Dimensions for Servo Motor

Unit(mm)

Models	X6MH005A	X6MH010A	X6MH015A	X6MH020A
LC	40	40	40	60
LA	$\phi 46$	$\phi 46$	$\phi 46$	$\phi 70$
LB	$\phi 30$	$\phi 30$	$\phi 30$	$\phi 50$
LZ	2- $\phi 4.3$	2- $\phi 4.3$	2- $\phi 4.3$	4- $\phi 5.4$
LR	25	25	25	30
S	$\phi 8 \text{ h}6$	$\phi 8 \text{ h}6$	$\phi 8 \text{ h}6$	$\phi 14 \text{ h}6 *3$
LL no brake [with brake]	57 [91]	71 [105]	93.8 [127.8]	70.5 [100]
LG	5	5	5	6.5
LE	3	3	3	3
LH	35	35	35	44.5
LK	14	14	14	25
T	3	3	3	5
KW	3 h9	3 h9	3 h9	5 h9
KH	6.2	6.2	6.2	11
TP	M3depth6	M3depth6	M3depth6	M5depth12
H	H-type cable length for lead-wire type	210	210	210

X6MH005A / X6MH010A / X6MH015A / X6MH020A*2

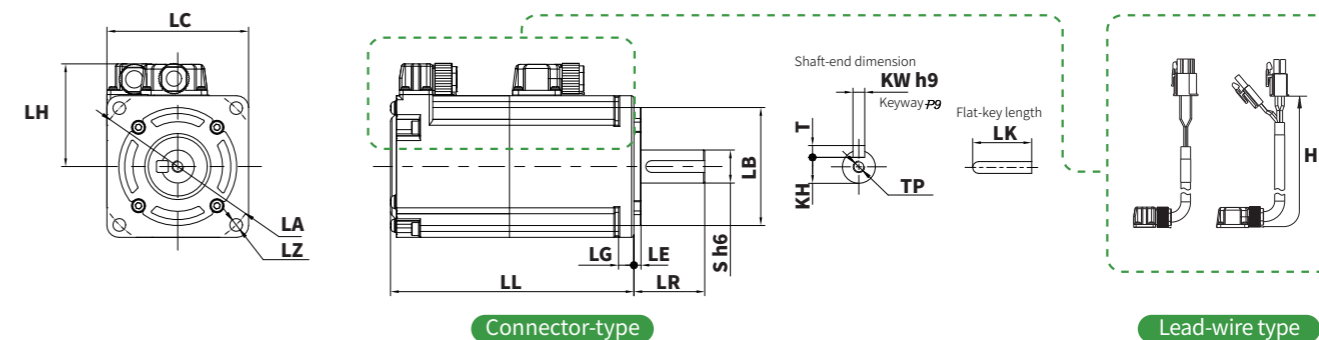

*1: Indicates that there is no brake model for this model
 *2: For X2 series servo motors, the lead-wire types are needed to be customized. For details, please contact our sales department.

Servo Motor Specifications



Items	Unit	X6MH040A	X6MH075A	X6MH100A	X6MH150A	
Rated power	W	400	750	1000	1500	
Rated voltage	V	220	220	220	220	
Fitting flange size	mm	60	80	130	130	
Rated torque	N.m	1.27	2.39	4.77	7.16	
Instantaneous max. torque	N.m	4.46	8.36	14.3	21.5	
Rated speed	r/min	3000	3000	2000	2000	
	r/min	6500	6000	3000	3000	
Max. speed	NOTE	*1	*1			
NOTE *1: The above data is only the theoretical performance of the motor design, so the motor performance may vary according to the different series of servo drives.						
Rated current	Arms	2.1	3.8	5.2	8	
Instantaneous max. current	Arms	7.36	13.3	15.6	24	
Moment of inertia	No brake	$\times 10^{-4}$ Kg.m ²	0.56	1.56	30.8	38.5
	With brake	$\times 10^{-4}$ Kg.m ²	0.58	1.66	32	39.7
Torque constant	N.m/A	0.67	0.648	0.918	0.895	
Induced voltage constant per phase	mV[r/min]	20.85	22.65	33.65	34.84	
Rated power rate	No brake	KW/S	28.8	36.6	7.39	13.3
	With brake	KW/S	27.8	34.4	7.11	12.9
Mechanical time constant	No brake	ms	1.24	0.97	7.54	4.9
	With brake	ms	1.29	1.03	7.84	5.05
Electrical time constant	ms	2.97	6.59	11.1	14.63	
Phase q-axis/d-axis inductance	mH	9.2/6.5	6/3.3	8.4/4.3	5.8/2.9	
Weight: No brake[with brake]	kg	1.22 [1.61]	2.25 [3.01]	6.4[8.0]	7.8[9.4]	
Permissible load	Radial load	N	245	392	490	490
	Axial load	N	98	147	196	196
Brake specification	Rated voltage	V	DC24V±10%			
	Rated current	A	0.36	0.42	0.9	0.9
	Brake power	w	9	9	9	9
	Static friction torque	N.m	1.6 or more	3.8 or more	14 or more	14 or more
Note: Holding brake	Suction time	ms	50 or less	70 or less	100 or less	100 or less
	Release time	ms	20 or less	20 or less	60 or less	60 or less
	Release voltage	ms	DC1V or more			

Torque characteristics

Instantaneous operation range (Red line), Continuous operation range (Blue line)

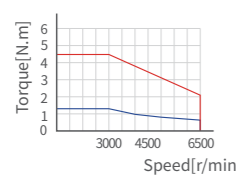

X6MH040A ▲

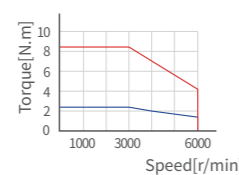

X6MH075A ▲



X6MH100A ▲



X6MH150A ▲

External Dimensions for Servo Motor

Unit(mm)

Models	X6MH040A	X6MH075A	X6MH100A	X6MH150A
LC	60	80	130	130
LA	φ70	φ90	φ145	φ145
LB	φ50	φ70	φ110	φ110
LZ	4-φ5.4	4-φ6.5	4-φ9	4-φ9
LR	30	35	55	55
S	φ14 h6	φ19 h6	φ22 h6	φ22 h6
LL no brake [with brake]	87.5 [117]	94.5 [128.5]	156 [176]	170 [190]
LN no brake [with brake]	—	—	108 [128]	122 [142]
LG	6.5	8	12	12
LE	3	3	6	6
LM1 no brake [with brake]	—	—	144.2[164.2]	158.2 [178.2]
LM3	—	—	69	83
LH1	44.5	54.5	115	115
LH3	—	—	60	60
LK	25	25	45	45
T	5	6	7	7
KW	5 h9	6 h9	8 h9	8 h9
KH	11	15.5	18	18
TP	M5depth12	M5depth12	M6depth20	M6depth20
H	H-type cable length for lead-wire type	210	210	—

X6MH040A / X6MH075A

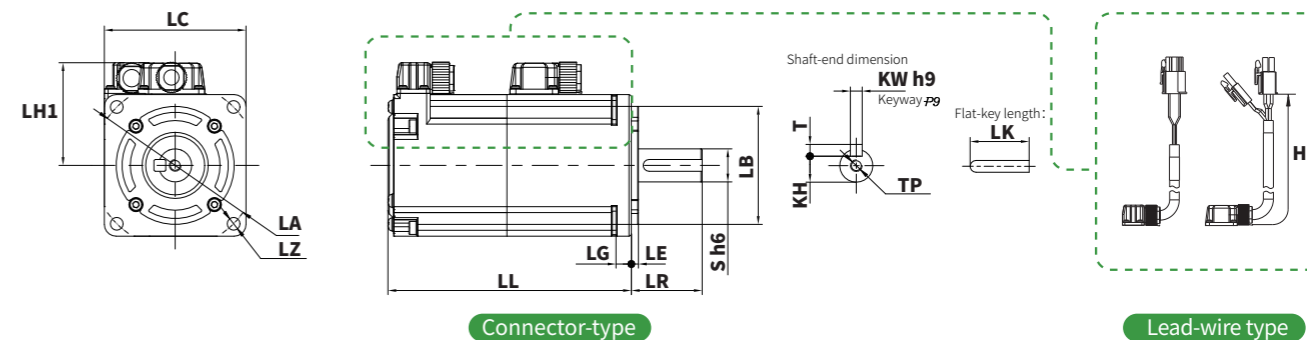

X6MH100A / X6MH150A

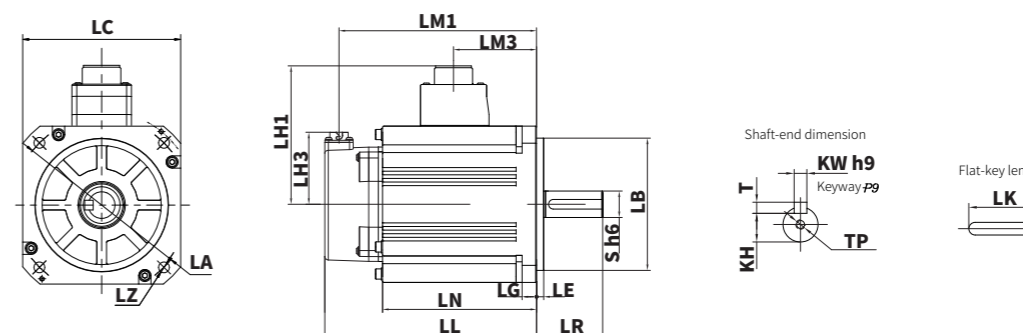

NOTE *2: For X6 series servo motors, the lead-wire types are needed to be customized. For details, please contact our sales department.

Servo Motor Specifications

100W 200W 400W 750W

Items	Unit	X6MH010H	X6MH020H	X6MH040H	X6MH075H	
Rated power	W	100	200	400	750	
Rated voltage	V	220	220	220	220	
Fitting flange size	mm	40	60	60	80	
Rated torque	N.m	0.32	0.64	1.27	2.39	
Instantaneous max. torque	N.m	1.11	2.23	4.46	8.36	
Rated speed	r/min	3000	3000	3000	3000	
	r/min	6500	6500	6500	6000	
Max. speed	NOTE		*1	*1	*1	
	NOTE *1: The above data is only the theoretical performance of the motor design, so the motor performance may vary according to the different series of servo drives.					
Rated current	Arms	0.92	1.4	2.4	3.8	
Instantaneous max. current	Arms	3.6	6.9	8.2	18.8	
Moment of inertia	No brake	$\times 10^{-4}$ Kg.m ²	0.092	0.47	0.73	3.15
	With brake	$\times 10^{-4}$ Kg.m ²	0.095	0.49	0.75	—*3
Torque constant	N.m/A	0.327	0.5	0.531	0.648	
Induced voltage constant per phase	mV[r/min]	13.3	14.61	20.4	22.65	
Rated power rate	No brake	KW/S	11.13	8.71	22.09	18.1
	With brake	KW/S	10.78	8.36	21.5	17.85
Mechanical time constant	No brake	ms	2.23	2.54	1.15	1.95
	With brake	ms	2.3	2.65	1.18	1.98
Electrical time constant	ms	0.986	2.58	4.1	6.59	
Phase q-axis/d-axis inductance	mH	11.9/8	—	6.9/4.3	6/3.3	
Weight: No brake[with brake]	kg	0.44[0.65]	0.95 [1.29]	1.45 [1.85]	2.65 [—*3]	
Permissible load	Radial load	N	68	245	245	392
	Axial load	N	58	98	98	147
Brake specification	Rated voltage	V	DC24V±10%			
	Rated current	A	0.25	0.36	0.36	0.42
	Brake power	w	6	9	9	10
	Static friction torque	N.m	0.38 or more	1.6 or more	1.6 or more	3.8 or more
	Note: Holding brake					
Suction time	ms	35 or less	50 or less	50 or less	70 or less	
Release time	ms	20 or less	20 or less	20 or less	20 or less	
Release voltage	ms	DC1V or more				

Torque characteristics

Instantaneous operation range Continuous operation range

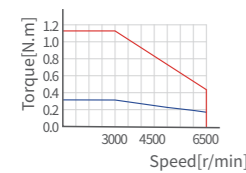

X6MH010H ▲

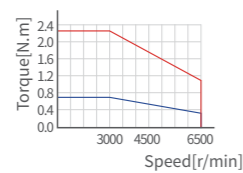

X6MH020H ▲

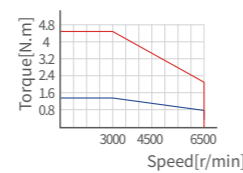

X6MH040H ▲

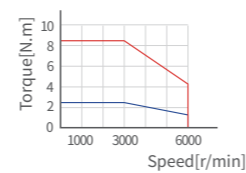

X6MH075H ▲

External Dimensions for Servo Motor

Unit(mm)

Models	X6MH010H	X6MH020H(Lead-wire type)	X6MH040H	X6MH075H(Lead-wire type)
LC	40	60	60	80
LA	φ46	φ70	φ70	φ90
LB	φ30	φ50	φ50	φ70
LZ	2-φ4.3	4-φ5.5	4-φ5.5	4-φ6.6
LR	25	30	30	35
S	φ8 h6	φ14 h6	φ14 h6	φ19 h6
LL no brake [with brake]	76.7 [110.7]	82.4 [111.9]	98.5 [128]	122 [—*3]
LG	5	6.5	6.5	8
LE	3	3	3	3
LH1	34.5	43.5	43.5	53.5
LK	14	25	25	25
T	3	5	5	6
KW	3 h9	5 h9	5 h9	6 h9
KH	6.2	11	11	15.5
TP	M3depth6	M5depth12	M5depth12	M5depth12
H	H-type cable length for lead-wire type	210	210	210

X6MH010H / X6MH020H / X6MH040H / X6MH075H

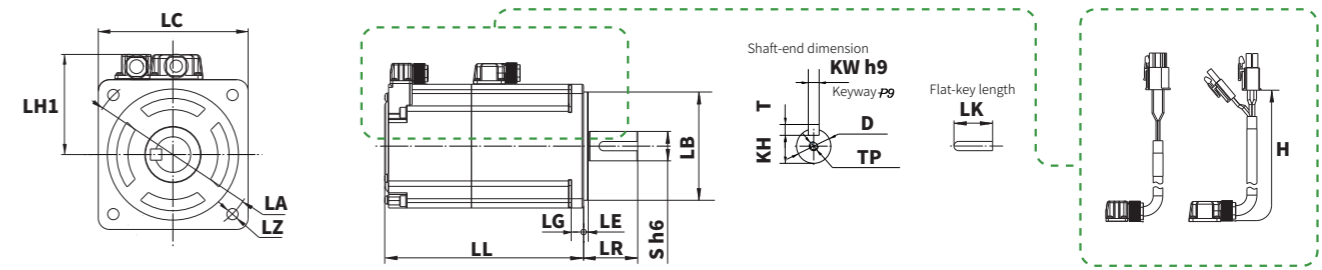

Connector-type

Lead-wire type

*2: For X6 series servo motors, the lead-wire types are needed to be customized. For details, please contact our sales department.

Servo Motor Specifications



Items	Unit	X6MQ010A	X6MQ020A	X6MQ040A	X6MQ100E	
Rated power	W	100	200	400	1000	
Rated voltage	V	220	220	220	220	
Fitting flange size	mm	60	80	80	80	
Rated torque	N.m	0.32	0.637	1.27	3.185	
Instantaneous max. torque	N.m	0.96	1.91	3.82	11.13	
Rated speed	r/min	3000	3000	3000	3000	
	r/min	6500	6500	6500	6000	
Max. speed	NOTE			*1	*1	
	NOTE *1: The above data is only the theoretical performance of the motor design, so the motor performance may vary according to the different series of servo drives.					
Rated current	Arms	0.95	2	2.6	5.7	
Instantaneous max. current	Arms	2.8	6.4	8.4	21.2	
Moment of inertia	No brake	$\times 10^{-4}$ Kg.m ²	0.16	0.47	0.87	2
	With brake	$\times 10^{-4}$ Kg.m ²	0.18	0.5	0.9	2.1
Torque constant	N.m/A	0.369	0.318	0.488	0.552	
Induced voltage constant per phase	mV[r/min]	11.6	12.2	19.6	21.2	
Rated power rate	No brake	KW/S	6.4	8.63	18.5	50.7
	With brake	KW/S	5.69	8.12	17.92	48.31
Mechanical time constant	No brake	ms	2.96	2.51	1.51	0.85
	With brake	ms	3.33	2.67	1.57	0.897
Electrical time constant	ms	1.76	3.52	5.41	7.6	
Phase q-axis/d-axis inductance	mH	13.9/7.8	7.3/3.9	9/4.9	3.8/2.6	
Weight: No brake[with brake]	kg	0.68 [0.92]	1.24 [1.74]	1.6 [2.1]	2.68 [3.45]	
Permissible load	Radial load	N	68	245	245	392
	Axial load	N	58	98	98	147
Brake specification	Rated voltage	V	DC24V±10%			
	Rated current	A	0.9	0.9	0.9	0.42
	Brake power	w	22	22	22	22
	Static friction torque	N.m	0.38-1.1	1.6 or more	1.6 or more	3.8 or more
Note: Holding brake	Suction time	ms	60 or less	60 or less	60 or less	70 or less
	Release time	ms	40 or less	40 or less	40 or less	20 or less
	Release voltage	ms	DC1.5V or more			

Torque characteristics

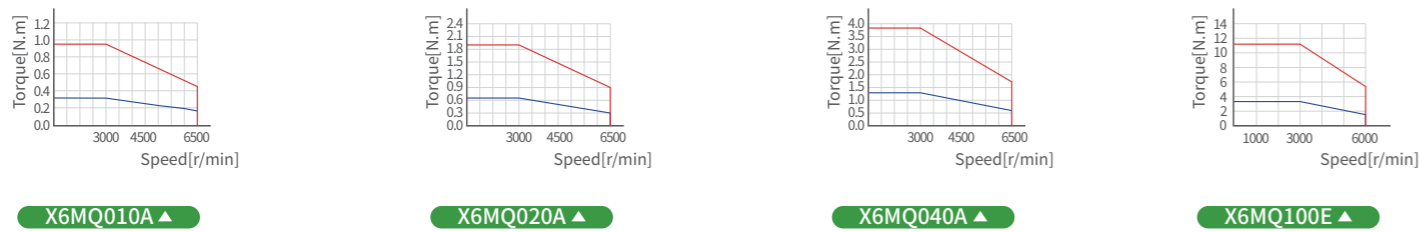

External Dimensions for Servo Motor

Unit(mm)

Models	X6MQ010A(Lead-wire type)	X6MQ020A(Lead-wire type)	X6MQ040A(Lead-wire type)	X6MQ100E
LC	60	80	80	80
LA	φ70	φ90	φ90	φ90
LB	φ50	φ70	φ70	φ70
LZ	4-φ5.4	4-φ6	4-φ6	4-φ6.5
LR	25	30	30	35
S	φ8 h6	φ11 h6	φ14 h6	φ19 h6
LL no brake [with brake]	61 [80.5]	66 [90]	76.8 [100.8]	108 [141.5]
LG	6.5	8	8	8
LE	3	3	3	3
LF	21	26	26	—
LP	φ14	φ19.7	φ19.7	—
LH1	43.5	53.5	53.5	53.5
LK	14	20	22	25
T	3	4	5	6
KW	3 h9	4 h9	5 h9	6 h9
KH	6.2	8.5	11	15.5
TP	M3depth6	M4depth8	M5depth12	M5depth12
H	H-type cable length for lead-wire type	210	210	210

X6MQ010A / X6MQ020A / X6MQ040A / X6MQ100E

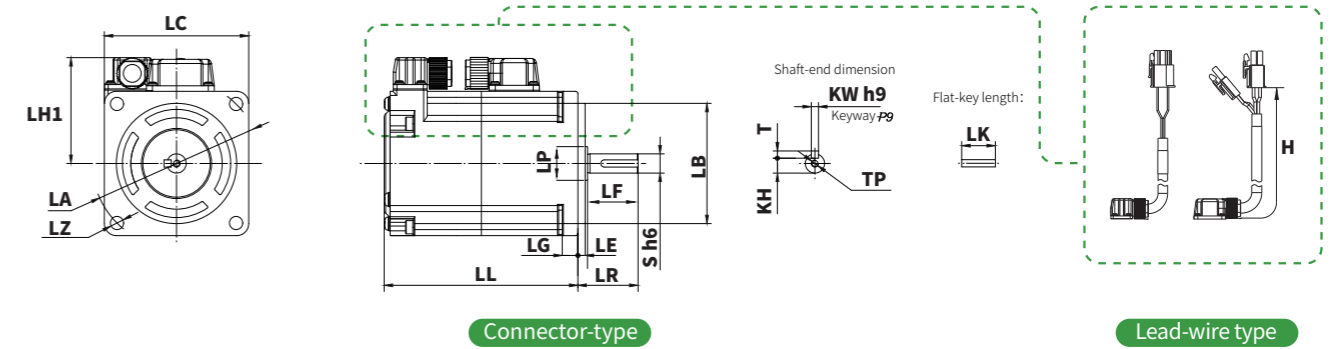

NOTE *2: For X6 series servo motors, the lead-wire types are needed to be customized. For details, please contact our sales department.

Servo Motor Specifications

750 W 850 W 1 KW 1.3 KW 1.8 KW

Items	Unit	X6MG075A	X6MG085A	X6MG100A	X6MG130A	X6MG180A	
Rated power	W	750	850	1000	1300	1800	
Rated voltage	V	220	220	220	220	220	
Fitting flange size	mm	80	130	130	130	130	
Rated torque	N.m	4.77	5.41	9.55	8.28	11.5	
Instantaneous max. torque	N.m	14.3	16.2	28.6	24.84	34.5	
Rated speed	r/min	1500	1500	1000	1500	1500	
Max. speed	r/min	2000	3000	1500	3000	3000	
Rated current	Arms	4.2	5.9	5.2	9.3	11.8	
Instantaneous max. current	Arms	15	18	16	28	35.5	
Moment of inertia	No brake	$\times 10^{-4} \text{Kg.m}^2$	2.88	14	12.1	20.2	26
	With brake	$\times 10^{-4} \text{Kg.m}^2$	3	15.2	13.3	21.4	27.2
Torque constant	N.m/A	1.135	0.918	1.83	0.895	0.964	
Induced voltage constant per phase	mV[r/min]	43.3	33.65	67.3	34.84	40.18	
Rated power rate	No brake	KW/S	79	63.29	75.4	33.9	50.87
	With brake	KW/S	75.84	58.26	68.6	32	48.6
Mechanical time constant	No brake	ms	1.01	3.43	1.12	2.57	2.06
	With brake	ms	1.05	3.72	1.23	2.72	2.15
Electrical time constant	ms	5.1	11.1	9.65	14.63	15.99	
Phase q-axis/d-axis inductance	mH	8.4/5.7	8.4/4.3	11/8.7	5.8/2.9	4.9/2.6	
Weight: No brake[with brake]	kg	3.46 [4.14]	5.53 [7.13]	6.91 [8.51]	6.89 [8.49]	8.14 [9.74]	
Permissible load	Radial load	N	392	490	490	490	
	Axial load	N	147	160	160	160	
Brake specification	Rated voltage	V	DC24V \pm 10%				
	Rated current	A	0.42	0.9	0.9	0.9	
	Brake power	w	10	10	10	10	
	Static friction torque	N.m	3.8 or more	14 or more	14 or more	14 or more	14 or more
	Note: Holding brake						
Suction time	ms	70 or less	100 or less	100 or less	100 or less	100 or less	
Release time	ms	20 or less	60 or less	60 or less	60 or less	60 or less	
Release voltage	ms	DC1V or more					

Torque characteristics



External Dimensions for Servo Motor

Unit(mm)

Models	X6MG075A(Lead-wire type)	X6MG085A	X6MG100A	X6MG130A	X6MG180A
LC	80	130	130	130	130
LA	$\phi 90$	$\phi 145$	$\phi 145$	$\phi 145$	$\phi 145$
LB	$\phi 70$	$\phi 110$	$\phi 110$	$\phi 110$	$\phi 110$
LZ	4- $\phi 6.6$	4- $\phi 9$	4- $\phi 9$	4- $\phi 9$	4- $\phi 9$
LR	35	55	55	55	55
S	$\phi 19 \text{ h6}$	$\phi 22 \text{ h6}$	$\phi 22 \text{ h6}$	$\phi 22 \text{ h6}$	$\phi 22 \text{ h6}$
LL no brake [with brake]	134 [177]	156 [176]	156 [176]	170 [190]	184 [204]
LN no brake [with brake]	—	108 [128]	108 [128]	122 [142]	136 [156]
LG	8	12	12	12	12
LE	3	6	6	6	6
LM1 no brake [with brake]	—	144.2[164.2]	144.2 [164.2]	158.2 [178.2]	172.2[192.2]
LM3	—	69	69	83	97
LH1	54	115	115	115	115
LH3	—	60	60	60	60
LK	25	45	45	45	45
T	6	7	7	7	7
KW	6 h9	8 h9	8 h9	8 h9	8 h9
KH	15.5	18	18	18	18
TP	M5depth12	M6depth20	M6depth20	M6depth20	M6depth20
H	210	—	—	—	—

X6MG075A

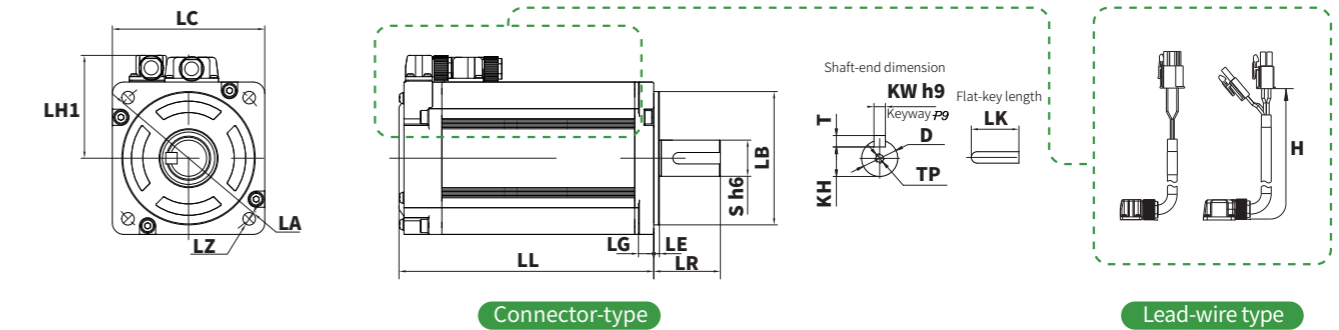

NOTE*2: For X6 series servo motors, the lead-wire types are needed to be customized. For details, please contact our sales department.

X6MG085A / X6MG100A / X6MG130A / X6MG180A

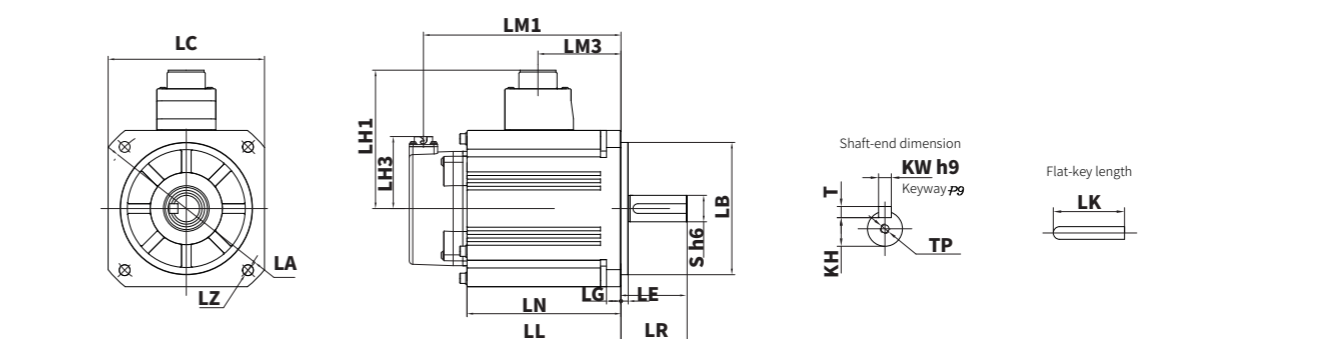

Servo Motor Specifications 850 W 1.3 KW 1.8 KW

Items	Unit	X6MG085S	X6MG130S	X6MG180S	
Rated power	W	850	1300	1800	
Rated voltage	V	220	220	220	
Fitting flange size	mm	130	130	130	
Rated torque	N.m	5.39	8.28	11.5	
Instantaneous max. torque	N.m	16.2	24.842	34.5	
Rated speed	r/min	1500	1500	1500	
Max. speed	r/min	3000	3000	3000	
Rated current	Arms	6.7	9.6	15.6	
Instantaneous max. current	Arms	20.1	28.8	46.8	
Moment of inertia	No brake	$\times 10^{-4} \text{Kg.m}^2$	13.9	19.9	26
	With brake	$\times 10^{-4} \text{Kg.m}^2$	16	22	28.1
Torque constant	N.m/A	0.859	0.891	0.748	
Induced voltage constant per phase	mV[r/min]	31.04	32.08	27	
Rated power rate	No brake	KW/S	20.9	35	50.9
	With brake	KW/S	18.2	31.6	47.1
Mechanical time constant	No brake	ms	2.74	2.23	1.95
	With brake	ms	3.16	2.46	2.29
Electrical time constant	ms	10.2	10.7	11.14	
Phase q-axis/d-axis inductance	mH	—	—	—	
Weight: No brake[with brake]	kg	5.7 [7.7]	7.3[9.2]	8.8[11.2]	
Permissible load	Radial load	N	490	490	
	Axial load	N	196	196	
Brake specification	Rated voltage	V	DC24V±10%		
	Rated current	A	0.41	0.41	0.41
	Brake power	w	10	10	10
	Static friction torque	N.m	14 or more	14 or more	14 or more
Note: Holding brake	Suction time	ms	100 or less	100 or less	100 or less
	Release time	ms	80 or less	80 or less	80 or less
	Release voltage	ms	DC1V or more		

Torque characteristics — Instantaneous operation range — Continuous operation range

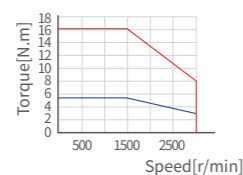

X6MG085S ▲

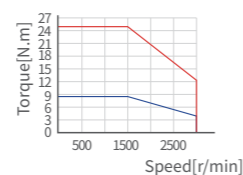

X6MG130S ▲

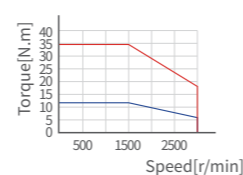

X6MG180S ▲

External Dimensions for Servo Motor

Unit(mm)

Models	X6MG085S	X6MG130S	X6MG180S
LC	130	130	130
LA	φ145	φ145	φ145
LB	φ110	φ110	φ110
LZ	4-φ9	4-φ9	4-φ9
LR	58	58	58
S	φ19 h6	φ22 h6	φ24 h6
LL no brake [with brake]	141.1 [177.1]	157.1[193.1]	175.1 [211.1]
LN no brake [with brake]	97.5[133.5]	113.5[149.5]	131.5[167.5]
LG	12	12	12
LE	6	6	6
LF	40	40	40
LM1 no brake [with brake]	129.4[165.4]	145.3[181.3]	163.3 [193.3]
LM2 no brake [with brake]	—[114.5]	—[130.5]	—[148.5]
LM3	83	99	117
LH1	105	105	105
LH2	79.5	79.5	79.5
LH3	60	60	60
LK	25 <td>25</td> <td>25</td>	25	25
T	5	6	7
KW	5 h9	6 h9	8 h9
KH	16	18.5	20
TP	M5depth16	M5depth16	M5depth16

X6MG085S/X6MG130S/X6MG180S

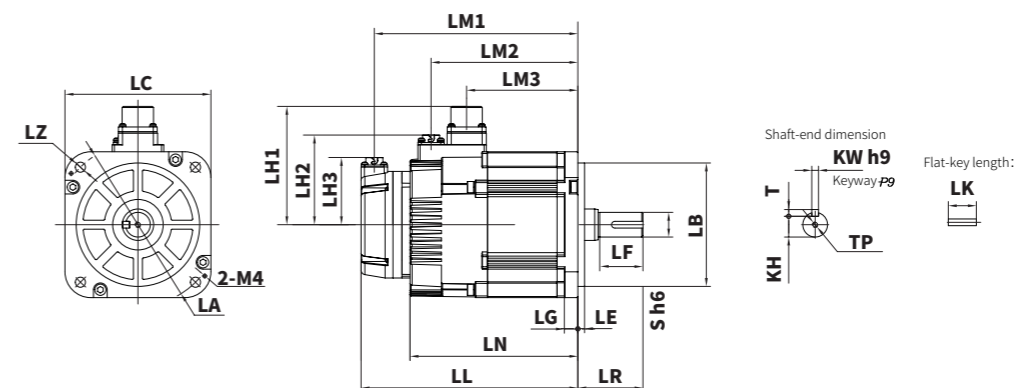

	Motor power	Model names	23bit absolute	17bit absolute	Brake	Oil seal	Flange	Shaft	Regular models	Accessories		Motor power	X3E[] _ _ _ A-A2				Remark			
													[A] Pulse control	[N] CANopen	[B] EtherCAT	Power specifications				
X6-MA Low-inertia	200W	X6MA020A-N2CD	●		●	●	60 flange	Φ14	Connecto r-type	① ⑤ ③① ① ⑥ ③①		200W	X3EA020A-A2	X3EN020A-A2	X3EB020A-A2	Single-phase AC220V	Futures			
		X6MA020A-B2CD														Futures				
	400W	X6MA040A-N2CD	●		●	●	60 flange	Φ14	Connecto r-type	① ⑤ ③① ① ⑥ ③①		400W	X3EA040A-A2	X3EN040A-A2	X3EB040A-A2	Single-phase AC220V	Futures			
		X6MA040A-B2CD														Futures				
	750W	X6MA075A-N2CD	●		●	●	80 flange	Φ19	Connecto r-type	① ⑤ ③① ① ⑥ ③①		750W	X3EA075A-A2	X3EN075A-A2	X3EB075A-A2	Single-phase AC220V	Futures			
		X6MA075A-B2CD														Futures				
	1KW	X6MA100A-N2LD	●		●	●	100 flange	Φ19	Aviation connector	⑪ ⑫ ③① ⑪ ⑫ ⑭ ③①		1KW	X3EA100A-A2	X3EN100A-A2	X3EB100A-A2	Three-phase AC220V				
		X6MA100A-B2LD																		
	1.5KW	X6MA150A-N2LD	●		●	●	100 flange	Φ19	Aviation connector	⑪ ⑫ ③① ⑪ ⑫ ⑭ ③①		1.5KW	X3EA150A-A2	X3EN150A-A2	X3EB150A-A2	Three-phase AC220V				
		X6MA150A-B2LD																		
	2KW	X6MA200A-N2LD	●		●	●	100 flange	Φ19	Aviation connector	⑪ ⑫ ③① ⑪ ⑫ ⑭ ③①		2KW	X3EA200A-A2	X3EN200A-A2	X3EB200A-A2	Three-phase AC220V				
		X6MA200A-B2LD																		
X6-MM Middle inertia	1KW	X6MM100A-N2LD	●		●	●	130 flange	Φ22	Aviation connector	⑪ ⑫ ③① ⑪ ⑬ ③①		1KW	X3EA100A-A2	X3EN100A-A2	X3EB100A-A2	Three-phase AC220V				
		X6MM100A-B2LD																		
	1.5KW	X6MM150A-N2LD	●		●	●	130 flange	Φ22	Aviation connector	⑪ ⑫ ③① ⑪ ⑬ ③①		1.5KW	X3EA150A-A2	X3EN150A-A2	X3EB150A-A2	Three-phase AC220V				
		X6MM150A-B2LD																		
2KW	X6MM200A-N2LD	●		●	●	130 flange	Φ22	Aviation connector	⑪ ⑫ ③① ⑪ ⑬ ③①		2KW	X3EA200A-A2	X3EN200A-A2	X3EB200A-A2	Three-phase AC220V					
	X6MM200A-B2LD																			
X6-MH High inertia	50W	X6MH005A-N2CD	●		●	●	40 flange	Φ8	Connecto r-type	① ③ ③① ① ④ ③①		50W	X3EA010A-A2	X3EN010A-A2	X3EB010A-A2	Single-phase AC220V				
		X6MH005A-B2CD																		
	100W	X6MH010A-N2CD	●		●	●	40 flange	Φ8	Connecto r-type	① ③ ③① ① ④ ③①		100W	X3EA010A-A2	X3EN010A-A2	X3EB010A-A2	Single-phase AC220V				
		X6MH010A-B2CD																		
	150W	X6MH015A-N2CD	●		●	●	40 flange	Φ8	Connecto r-type	① ③ ③① ① ④ ③①		150W	X3EA020A-A2	X3EN020A-A2	X3EB020A-A2	Single-phase AC220V				
		X6MH015A-B2CD																		
	200W	X6MH020A-N2CD	●		●	●	60 flange	Φ14	Connecto r-type	① ⑤ ③① ① ⑥ ③①		200W	X3EA020A-A2	X3EN020A-A2	X3EB020A-A2	Single-phase AC220V				
		X6MH020A-B2CD																		
		X6MH020A-N2JD																		
	400W	X6MH040A-N2CD	●		●	●	60 flange	Φ14	Connecto r-type	① ⑤ ③① ① ⑥ ③①		400W	X3EA040A-A2	X3EN040A-A2	X3EB040A-A2	Single-phase AC220V				
		X6MH040A-B2CD																		
	750W	X6MH075A-N2CD	●		●	●	80 flange	Φ19	Connecto r-type	① ⑤ ③① ① ⑥ ③①		750W	X3EA075A-A2	X3EN075A-A2	X3EB075A-A2	Single-phase AC220V				
		X6MH075A-B2CD																		
	1KW	X6MH100A-N2LD	●		●	●	130 flange	Φ22	Aviation connector	⑪ ⑫ ③① ⑪ ⑬ ③①		1KW	X3EA100A-A2	X3EN100A-A2	X3EB100A-A2	Three-phase AC220V				
		X6MH100A-B2LD																		
	1.5KW	X6MH150A-N2LD	●		●	●	130 flange	Φ22	Aviation connector	⑪ ⑫ ③① ⑪ ⑬ ③①		1.5KW	X3EA150A-A2	X3EN150A-A2	X3EB150A-A2	Three-phase AC220V				
X6MH150A-B2LD																				

Accessories specifications for connector-type servo motors if flange 40 to 80

- ① SVCAB-ENC075CA-ABS-***L-05 Absolute encoder cable
- ② SVCAB-ENC075CA-***L-05 Incremental encoder cable
- ③ SVCAB-PWR010CA-***L-05 UVW power cable 50W~100W
- ④ SVCAB-PWB010CA-***L-05 UVW power cable with brake 50W~100W
- ⑤ SVCAB-PWR075CA-***L-05 UVW power cable 200W~1KW
- ⑥ SVCAB-PWB075CA-***L-05 UVW power cable with brake 200W~1KW

Aviation connector specifications for servo motor of flange 100&130&180

- ⑪ ENC-TE 1KW Encoder accessories (10-pin aviation connector + 1394 connector)
 - ⑫ PWR-CON 1KW 4-core power aviation connector, for flange 100&130
 - ⑬ PWR-CON 1KW-9P 9-pin brake power aviation connector, for flange 100&130
 - ⑭ PWB-CON- 1KW 2-core brake power connector *1
 - ⑮ PWR-CON 7.5KW 4-core power aviation connector, for flange 180
- *1 For flange 130 models, only X2MA100A/150A/200A/X2MG230A and 180 flange models require PWB-CON- 1KW

Accessories specifications for lead-wire type servo motor of flange 40 to 80

- ⑰ ENC-TE 750W 2 packs of encoder accessories (6-hole plastic connector + 1394 connector)
- ⑱ PWR-CON 750W 4-hole power plastic connector
- ⑲ PWB-CON 750W 6-hole power brake plastic connector

Other accessories specifications

- ⑳ SV-BAT Absolute battery box with 1394 connector



	Power	Models	17bit absolute	17bit absolute	Brake	Oil seal	Flange	Shaft diameter	Regular model	Applicable accessories		Power	X3E [] _ _ _ A-A2				Notes
													[A]Pulse control	[N] CANopen	[B] EtherCAT	Power specifications	
X6-MHH Ultrahigh inertia	100W	X6MH010H-N2CD	●		●	●	40 flange	Φ8	Connector-type	① ③ ③1 ① ④ ③1	X6-MHH Ultrahigh inertia	100W	X3EA010A-A2	X3EN010A-A2	X3EB010A-A2	Single-phase AC220V	
		X6MH010H-B2CD															
	200W	X6MH020H-N2LD	●		●	●	60 flange	Φ14	Lead-wire type	②1 ②2 ③1 ②1 ②3 ③1		200W	X3EA020A-A2	X3EN020A-A2	X3EB020A-A2	Single-phase AC220V	
		X6MH020H-B2LD															
	400W	X6MH040H-N2CD	●		●	●	60 flange	Φ14	Connector-type	① ⑤ ③1 ① ⑥ ③1		400W	X3EA040A-A2	X3EN040A-A2	X3EB040A-A2	Single-phase AC220V	
X6MH040H-B2CD																	
750W	X6MH075H-N2LD	●		●	●	80 flange	Φ19	Lead-wire type	②1 ②2 ③1 ②1 ②3 ③1	750W	X3EA075A-A2	X3EN075A-A2	X3EB075A-A2	Single-phase AC220V			
X6-MQ Special flange/Flat-type/small flange	100W	X6MQ010A-N2LD	●		●	●	60 flange	Φ8	Lead-wire type	②1 ②2 ③1 ②1 ②3 ③1	X6-MQ Special flange/Flat-type/small flange	100W	X3EA010A-A2	X3EN010A-A2	X3EB010A-A2	Single-phase AC220V	
		X6MQ010A-B2LD															
	200W	X6MQ020A-N2LD	●		●	●	80 flange	Φ11	Lead-wire type	②1 ②2 ③1 ②1 ②3 ③1		200W	X3EA020A-A2	X3EN020A-A2	X3EB020A-A2	Single-phase AC220V	
		X6MQ020A-B2LD															
	400W	X6MQ040A-N2LD	●		●	●	80 flange	Φ14	Lead-wire type	②1 ②2 ③1 ②1 ②3 ③1		400W	X3EA040A-A2	X3EN040A-A2	X3EB040A-A2	Single-phase AC220V	
		X6MQ040A-B2LD															
1KW	X6MQ100E-N2CD	●		●	●	80 flange	Φ19	Connector-type	① ⑤ ③1 ① ⑥ ③1	1KW	X3EA100A-A2	X3EN100A-A2	X3EB100A-A2	Three-phase AC220V			
	X6MQ100E-B2CD																
X6-MG Low-speed and Large-torque	750W	X6MG075A-N2LD	●		●	●	80 flange	Φ19	Lead-wire type	②1 ②2 ③1 ②1 ②3 ③1	X6-MG Low-speed and Large-torque	750W	X3EA075A-A2	X3EN075A-A2	X3EB075A-A2	Single-phase AC220V	
		X6MG075A-B2LD															
	1KW	X6MG100A-N2LD	●		●	●	130 flange	Φ22	Aviation connector	⑪ ⑫ ③1 ⑪ ⑬ ③1		1KW	X3EA100A-A2	X3EN100A-A2	X3EB100A-A2	Three-phase AC220V	
		X6MG100A-B2LD															
	850W	X6MG085A-N2LD	●		●	●	130 flange	Φ22	Aviation connector	⑪ ⑫ ③1 ⑪ ⑬ ③1		850W	X3EA100A-A2	X3EN100A-A2	X3EB100A-A2	Three-phase AC220V	
		X6MG085A-B2LD															
	1.3KW	X6MG130A-N2LD	●		●	●	130 flange	Φ22	Aviation connector	⑪ ⑫ ③1 ⑪ ⑬ ③1		1.3KW	X3EA150A-A2	X3EN150A-A2	X3EB150A-A2	Three-phase AC220V	
		X6MG130A-B2LD															
1.8KW	X6MG180A-N2LD	●		●	●	130 flange	Φ22	Aviation connector	⑪ ⑫ ③1 ⑪ ⑬ ③1	1.8KW	X3EA200A-A2	X3EN200A-A2	X3EB200A-A2	Three-phase AC220V			
	X6MG180A-B2LD																
X6-MGS Low-cogging Cutting	850W	X6MG085S-N2LD	●		●	●	130 flange	Φ19	Aviation connector	⑪ ⑫ ③1 ⑪ ⑬ ③1	X6-MGS Low-cogging Cutting	850W	X3EA150A-A2	X3EN150A-A2	X3EB150A-A2	Three-phase AC220V	
		X6MG085S-B2LD															
	1.3KW	X6MG130S-N2LD	●		●	●	130 flange	Φ22	Aviation connector	⑪ ⑫ ③1 ⑪ ⑬ ③1		1.3KW	X3EA150A-A2	X3EN150A-A2	X3EB150A-A2	Three-phase AC220V	
		X6MG130S-B2LD															
	1.8KW	X6MG180S-N2LD	●		●	●	130 flange	Φ24	Aviation connector	⑪ ⑫ ③1 ⑪ ⑬ ③1		1.8KW	X3EA250A-A2	X3EN250A-A2	X3EB250A-A2	Three-phase AC220V	
		X6MG180S-B2LD															

Accessories specifications for connector-type servo motors if flange 40 to 80

- ① SVCAB-ENC075CA-ABS-***L-05 Absolute encoder cable
- ② SVCAB-ENC075CA-***L-05 Incremental encoder cable
- ③ SVCAB-PWR010CA-***L-05 UVW power cable 50W~100W
- ④ SVCAB-PWB010CA-***L-05 UVW power cable with brake 50W~100W
- ⑤ SVCAB-PWR075CA-***L-05 UVW power cable 200W~1KW
- ⑥ SVCAB-PWB075CA-***L-05 UVW power cable with brake 200W~1KW

Aviation connector specifications for servo motor of flange 100&130&180

- ⑪ ENC-TE 1KW Encoder accessories (10-pin aviation connector + 1394 connector)
 - ⑫ PWR-CON 1KW 4-core power aviation connector, for flange 100&130
 - ⑬ PWR-CON 1KW-9P 9-pin brake power aviation connector, for flange 100&130
 - ⑭ PWB-CON- 1KW 2-core brake power connector *1
 - ⑮ PWR-CON 7.5KW 4-core power aviation connector, for flange 180
- *1 For flange 130 models, only X2MA100A/150A/200A/X2MG230A and 180 flange models require PWB-CON- 1KW

Accessories specifications for lead-wire type servo motor of flange 40 to 80

- ②1 ENC-TE 750W 2 packs of encoder accessories (6-hole plastic connector + 1394 connector)
- ②2 PWR-CON 750W 4-hole power plastic connector
- ②3 PWB-CON 750W 6-hole power brake plastic connector

Other accessories specifications

- ③1 SV-BAT Absolute battery box with 1394 connector





SVCAB-ENC 075 C A – ABS-010L-05

1 2 3 4 5 6 7

1 Product type	
ENC	Encoder cable
PWR	4-core power cable
PWB	6-core power cable with brake

5 Encoder type	
ABS	Absolute
N/A	Incremental

2 Motor power	
010	50W~150W
075	200W~1KW

6 Length specifications (unit 0.1m)	
L	Length identification *1

3 Connector-type	
C	Flange 40 to 80

7 Cable flexibility	
01	Fixed
05 (regular)	5 million times
10	10 million times
20	20 million times
A0	For swinging

4 Connector-type	
A	Forward-The leading direction at the front end
B	Reverse-The leading direction at the back end



*1The regular length specifications in our stock is 0.5M/1M/2M/3M/5M/8M/10M. For other length specifications (minimum unit 0.5 meters), please consult our sales department in advance.

IP67
Waterproof / dustproof

Power cable

For connector-type servo motor

Encoder cable

Flexible cables

EMC

Superior quality

Advantages

- The motor cables connected directly to the servo drive, reducing the connection and greatly improving the reliability.
- The protection level of the motor connector upgraded to IP67, vibration-resistance, dustproof and waterproof.
- Encoder cables are treated with metal shielding layer, which has strong anti-interference ability!
- Various specifications of cables can be customized based on the different application occasions. HCFA designated high-quality raw material suppliers for centralized procurement. (See Naming rule 7 for cables)

From the 2nd quarter of 2021, our company started releasing connector-type servo motor with 40~80 flanges as the regular model. Lead-wire servo motors will be discontinued from December 2021, if still needed, the customized application process is required. For details, refer to page 67 or consult our sales staff.

Accessories Specifications for Connector-type Servo Motor

Cables	Model name	Diagram
Absolute encoder cable	SVCAB-ENC075CA-ABS-***L-05	
Incremental encoder cable	SVCAB-ENC075CA-***L-05	
50W~150W UVV power cable	SVCAB-PWR010CA-***L-05	
50W~150W UVV power cable with brake	SVCAB-PWB010CA-***L-05	
200W~1000W UVV power cable	SVCAB-PWR075CA-***L-05	
200W~1000W UVV power cable with brake	SVCAB-PWB075CA-***L-05	

Aviation connectors for servo motor of flange 100&130&180

Accessories	Model name	Diagram
Encoder accessories (10-pin aviation connector + 1394 connector)	ENC-TE 1KW	1
4-core power aviation connector, for flange 100&130	PWR-CON 1KW	2
9-pin brake power aviation connector, for flange 100&130	PWR-CON 1KW-9P	3
2-core brake power connector *1	PWB-CON- 1KW	4
4-core power aviation connector, for flange 180	PWR-CON 7.5KW	5

Accessories	Model name	Diagram
Adapter cable with 1394 connector Absolute battery box	SVBOX-ENCABS	6A

注*Flange 130 are only required for X2MA100A/150A/200A/X2MG230A

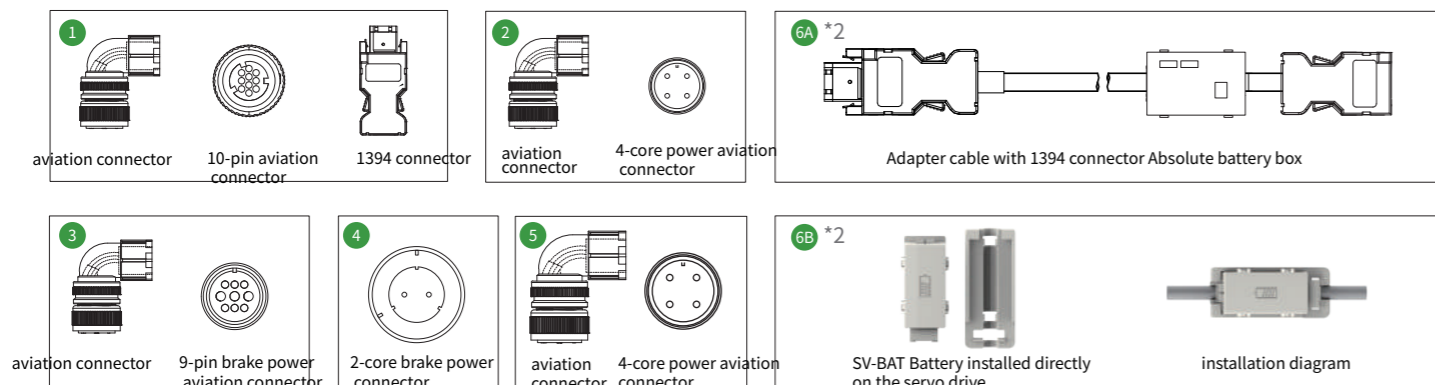

Other accessory specifications

Accessories	Model name	Applicable servo drive	Description
Battery installed directly on the servo drive 6B	SV-BAT	SV-X6 All series SV-X5E All series	Encoder cable external battery, installed on the side of the servo drive
Multifunctional absolute battery panel	SV-ENC-BAT	SV-X6 All series SV-X5E All series	Encoder cable external battery
CAN bus connection cable	SV-CAB-0.3M	SV-X6EN type full power SV-X6FN type full power	CANopen bus-type CN4, CN5 interface
CAN terminal resistance	SV-TR-120	SV-X6EN type full power SV-X6FN type full power	CANopen bus-type CN4, CN5 interface
EtherCAT/profinet bus cable	SV-ECAT-0.35M	SV-X6EB type full power SV-X6ER type full power SV-X6FB type full power SV-X6FR type full power	X6 EtherCAT and profinet bus-type CN4, CN5 interface
		SV-X5EB type full power	X5E EtherCAT bus-type CN4, CN5 interface
RS485 cable 0.2m	SV-RS485-0.2M	SV-X6FA full power SV-X6FB full power SV-X6FN full power SV-X6FR full power	All-function models CN1 For 485 communication and analogue AO output port
STO cable 2m	SV-STO-2M	SV-X6FA full power SV-X6FB full power SV-X6FN full power SV-X6FR full power	X6 all-function models CN2 interface STO External safety switch
		SV-X5E 1KW or less STO models	X5E models CN2 interface STO External safety switch
Second Encoder cable 2m	SV-MIII-2M	SV-X6FA full power SV-X6FB full power	All-function models CN8 interface
Gantry synchronisation signal Cable 0.4m	SV-GS-0.4M	SV-X6FA full power	Gantry synchronisation models CN8 interface
750W or less brake resistors	SV-BRAKE-75A	SV-X6 All series, models of 750W or less SV-X5E All series, models of 750W or less	X6 series brake resistor P, BR interface X5E series brake resistor P, BR interface
1KW~1.5KW brake resistors	SV-BRAKE-100A	SV-X6 All series models of 1KW to 1.5KW SV-X5E All series models of 1KW to 1.5KW	X6 series brake resistor P, BR interface X5E series brake resistor P, BR interface
2KW~2.5KW brake resistors	SV-BRAKE-200A	SV-X6 All series 220V series, models of 2KW to 2.5KW SV-X5E All series, models of 2KW to 2.5KW	X6 series brake resistor P, BR interface X5E series brake resistor P, BR interface
Anti-interference magnetic ring	Magnetic ring	All series	Installed on the power cable and encoder cable, with anti-interference

Other accessory specifications

Waterproof connector/compact accessories	Specifications
ENC-TE 750W-F	6-core waterproof encoder connector + 1394 connector encoder accessory pack
PWR-CON 750W-F	4-core waterproof power connector, for flange 40 to 80
PWB-CON 750W-F	6-core waterproof power connector with brake, for flange 40 to 80
PWR-CON 1KW-F	6-core waterproof power connector, for flange 130

For servo motor of flange 40 to 80

Accessories	Model name	Diagram
2 packs of encoder accessories ((6-hole plastic connector + 1394 connector)	ENC-TE 1KW	7
4-hole power connector accessories	PWR-CON 750W	8
6-hole power brake connector accessories	PWB-CON 750W	9

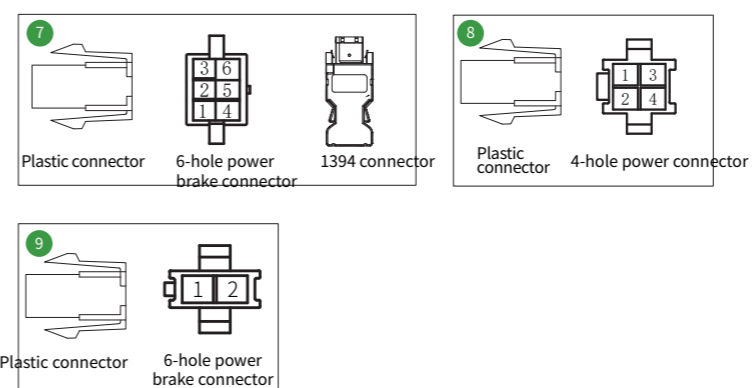

Cable for Lead-wire Type Servo Motor (customized products)

Encoder cable	Specifications
SVCAB-ENC75A-3M	Absolute encoder cable, for lead-wire type servo motor flange 40 to 80, 3 meters
CAB-ENC100A-3M	Incremental encoder cable, for lead-wire type servo motor flange 100&130&180, 3 meters
CAB-ENC100A-ABS-3M	Absolute encoder cable with battery box, for lead-wire type servo motor flange 100&130&180, 3 meters
Power cable	Specifications
CAB-PWR75A-3M	4-core power cable, for lead-wire type servo motor flange 40 to 80, 3 meters
CAB-PWR100A-3M	4-core power cable, for lead-wire type servo motor flange 100&130, 3 meters
CAB-PWR400C-3M	4-core power cable, for lead-wire type servo motor of 2KW to 5KW, flange 180, 3 meters
CAB-PWR750C-5M	CAB-PWR750C-5M 4-core power cable, for lead-wire type servo motor of 5.5KW to 7.5KW, flange 180, 5 meters
Power brake cable	Specifications
CAB-PWB75A-3M	9-core power cable, for lead-wire type servo motor flange 130, 3 meters
CAB-PWB100A-3M	6-core power brake cable, for lead-wire type servo motor flange 40 to 80, 3 meters
CAB-PWD100A-3M	2-core power cable, for lead-wire type servo motor flange 100&130, 3 meters
Waterproof connector cable	Specifications
SVCAB-ENC75A-3M-F	6-core waterproof absolute encoder cable, for lead-wire type servo motor flange 40 to 130, 3 meters
CAB-PWR75A-3M-F	4-core waterproof power cable, for lead-wire type servo motor flange 40 to 80, 3 meters
CAB-PWB75A-3M-F	6-core waterproof power brake cable, for lead-wire type servo motor flange 40 to 80, 3 meters
CAB-PWB100A-3M-F	9-core waterproof power brake cable, for lead-wire type servo motor flange 130, 3 meters

HCFA Q-Series Standard PACs

HCFA Y7-Series High-end Servo Products

Focus on 9 major industries of industrial automation and create overall solutions!



Standard IEC61131-3 specification 6 programming languages

Based on standard PLC OPEN standard motion control - Linear/circular/spiral interpolation / electronic cam / flying shear / rotary shear



The new-generation Y7-series advanced servo system adopts the brand-new control algorithm platform to meet the diverse control needs of customers in different industries with excellent driving performance, rich buses and extended functions. At the same time, it's equipped with 7 core performances such as higher dynamic response, accurate positioning and reliability, faster speed and easy-to-use, which comprehensively helps customers in industrial upgrading and enhances the efficiency of machine tools.

Let's cooperate to redefine the performance of your equipment

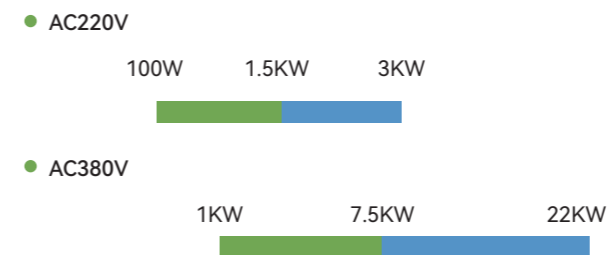

2021-09-02
Officially released on
2021-09-02, welcome to consult!

