

To be the most valuable industrial automation core components and solution provider



Stock code: 688320.SH

R&D Centers

4

Set up nationally

Sales Office

40+

Sales elites gathering

Global Distributor

400+

Products sold worldwide

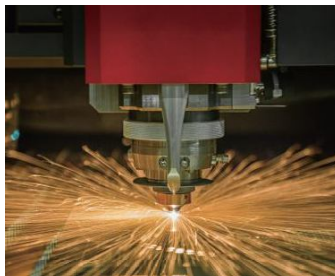

The products are widely used in OEM fields such as photovoltaic, 3C, lithium batteries, robots, packaging, textiles, logistics, lasers, machine tool, etc.



Much smaller
To meet the extreme installation needs

97mm

Support rail and screw mounting simultaneously

D3E DRIVES

Compact & high ease of use

Compact design
Quick response
Rich interfaces

Support RS485/EtherCAT/CanOpen

Using PUSH-IN connector, easy to pull and push, greatly shorten the wiring time

No terminal block is required, power supply connection can be done directly

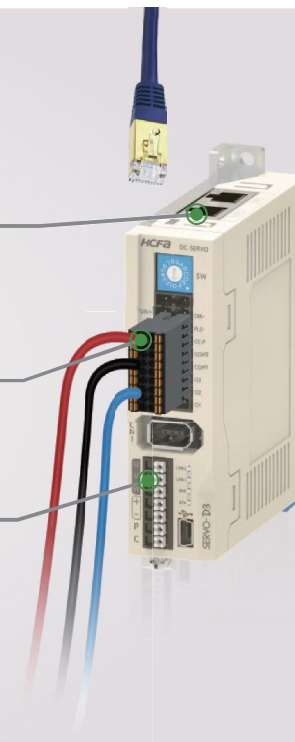

SV-D3E B 010 L - E

1 2 3 4

1	Types	
A	Pulse type	
B	EtherCAT type	
N	CANopen type	
G	Analog type	

2	Output power	
010	100W	
020	200W	
040	400W	
075	750W	

3	Main power voltage	
L	DC48V	
M ¹	DC24V	

4	Control power	
E	Internal control power	

NOTE *1: 24VDC models:
SV-D3EA010M-E SV-D3EA020M-E
SV-D3EN010M-E SV-D3EN020M-E
SV-D3EB010M-E SV-D3EB020M-E

■ Excellent user experience

From equipment design to installation and commissioning and maintenance, HCFA fully considers user experience and chooses standard general solutions to improve efficiency.

■ Programming software HCS-Studio

Compatible with all HCFA servo systems. Set the parameters of servo drive through serial port or miniUSB connection. The software can be automatically upgraded, with simple interface and easy maintenance.



■ Vibration suppressed to make the movement smoother

Supports Notch Filter, low-frequency resonance suppression, and adaptive filter to quickly suppress vibration.

● Pulse-type (100W)

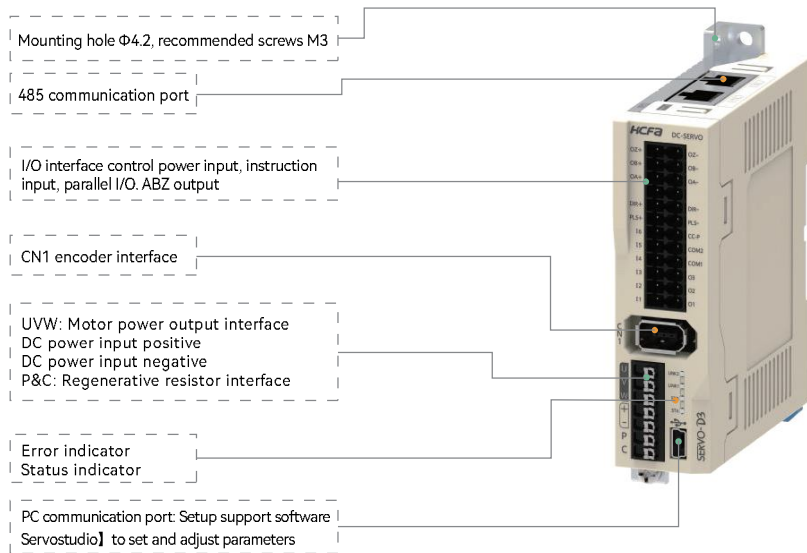

● Pulse-type (400W/750W)

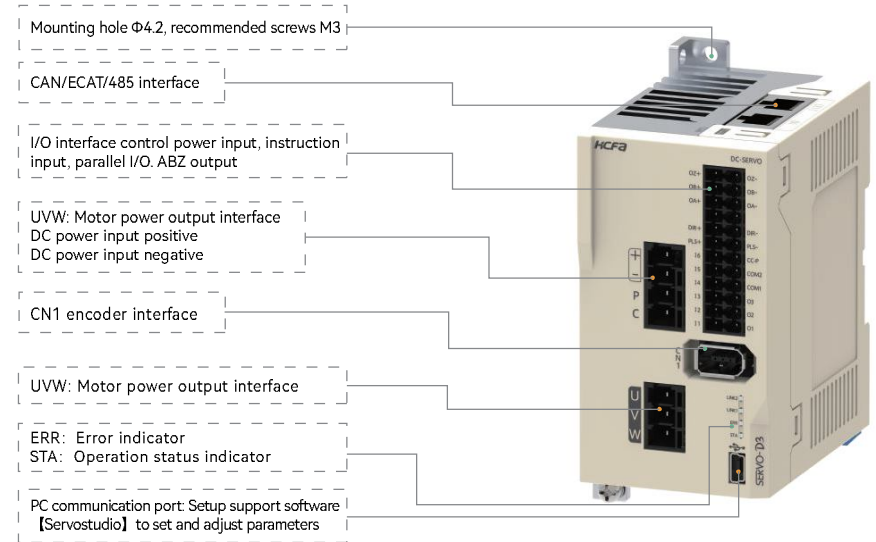

● Bus-type (100W)

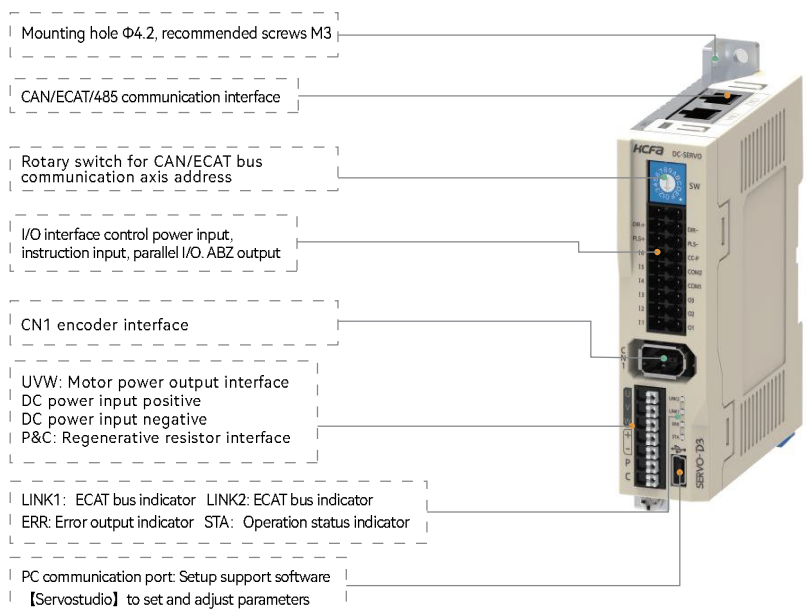

● Bus-type (400W/750W)

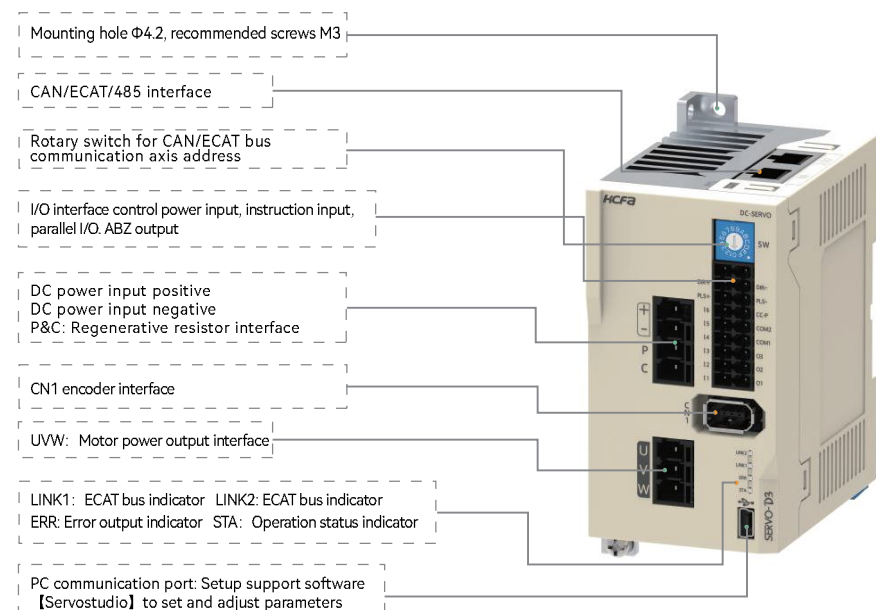

Environment Specifications

Items	Specifications								
	Pulse input type				EtherCAT/CANOpen bus-type				
Models									
Applicable motor power	10w	20w	30w	40w	50w	100w	200w	400w	750w
Encoder feedback	17bit encoder								
Input power	Main circuit power	DC 48V							
	IO control power	DC 24V							
Environmental specifications	Temperature	Ambient temperature for use	0~55°C						
		Ambient temperature for storage	-20~65°C						
	Humidity	Ambient humidity for use	20~85%RH or less (no condensation)						
		Ambient humidity for storage	20~85%RH or less (no condensation)						
	Atmosphere for use & storage	Indoors (Not subject to direct sunlight); free from corrosive gas, flammable gas, oil mist, or dust							
Altitude	1000m or less above sea level								
Vibration	5.8m/s ² (0.6G) or less, 10~60Hz (No continuous operation allowed at frequency of resonance)								
绝缘耐压	1 minute at 1500 VAC across the primary and FG								

Performance Specifications

Control type		Three-phase PWM inverting sine-wave
Encoder feedback		Single-turn absolute 17-bit (multi-turn absolute with battery)
Control signal	Input	6 inputs (24VDC, photo-coupler insulation) Switch by control mode
	Output	3 outputs (24VDC, photo-coupler insulation, open-collector output) Switch by control mode
Pulse signal	Input	2 inputs (photo-coupler insulation, RS-422 differential, open-collector)
	Output	4 outputs (A/B/Z-phase RS-422 differential, Z-phase open collector output)
Analog signal	Input	2 inputs (DC+10V) (For analog-type models)
Communication function	USB	Connection with PC (with "Servostudio" software)
	Bus	Supporting CAN, ECAT and 485 communication
Regeneration function		External regenerative resistor possible
Dynamic brake		Not built-in
Control mode		6 control modes: Position control, speed control, torque control, position/speed control, position/torque control, speed/torque control

Function Specifications

Items	Specifications		
Position control	Control input	Servo ON, alarm reset, deviation counter clear, positive/negative direction over-travel, command input reversal, internal command selection, internal position command input enabled, homing start etc.	
	Control output	Alarm state, servo ready, brake off, torque limiting, homing proximity, position reached, homing return completion, motor rotation output, zero-speed output, etc.	
	Pulse input	Max input pulse frequency	Differential input: Up to 500KHz, pulse width larger than 1us; Open-collector input: Up to 200KHz, pulse width larger than 2.5us
		Input pulse type	Differential input; open-collector
		Input pulse form	Pulse+ direction, A-Phase + B-Phase, CW+CCW
	Pulse output	Electronic gear	A/B A: 1~1073741824 B: 1~1073741824, Encoder resolution/10000000 < A/B < Encoder resolution/2.5
		Command filter	Smoothing filter, FIR filter
Output pulse form		A-Phase, B-Phase: Differential output Z-Phase: Differential output	
Speed control	Control input	Servo ON, alarm reset, speed instruction negation, zero-speed clamp, internal command selection, external forward/reverse torque limit, emergency stop etc.	
	Control output	Alarm state, servo ready, brake off, speed reached, torque limiting, speed limiting, zero-speed output, speed coincidence, motor rotation output etc.	
Torque control	Internal speed instruction	0~16 segment speed selection by using DI terminal combination	
	Control input	Servo ON, alarm reset, torque instruction negation, zero-speed clamp etc.	
	Control output	Alarm state, servo ready, brake off, torque limiting, speed limit output, emergency stop etc.	
Protective functions	Speed limit	Positive/ negative speed limit P03.27, P03.28	
	Speed monitoring	Provided	
	Vibration control	Provided	
	Adaptive notch filter	Provided	
	Auto-tuning	Provided	
	Encoder output division and multiplication	Provided	
	Internal position control	Provided	
	PC setting	Setup support software 「 Servostudio 」 to adjust parameters	
	Protective functions		Overvoltage, power supply error, overcurrent, overheat, overload, encoder error, over speed, position deviation too large, parameter error

External Dimensions

Models SV-D3E □□□	External dimensions			Weight(kg)
	W (mm)	H (mm)	D (mm)	
010	25	104	76.5	0.17
020	50	104	76.5	0.37
040	50	104	76.5	0.37
075	50	104	76.5	0.37

SV-D3E010

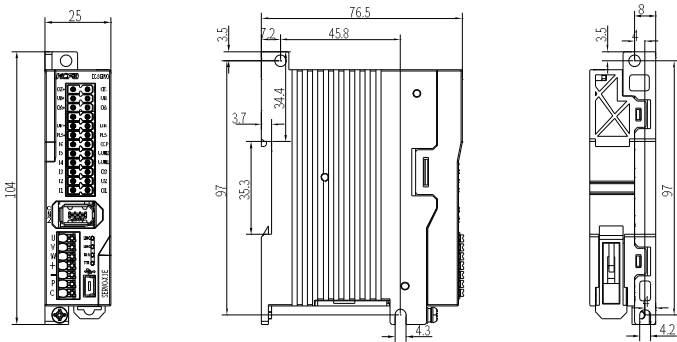

SV-D3E020 SV-D3E040 SV-D3E075

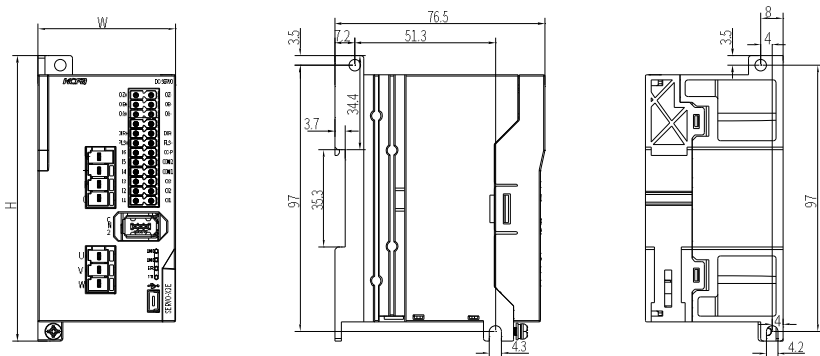

X6MN Series

Much smaller

Much faster

More accurate!

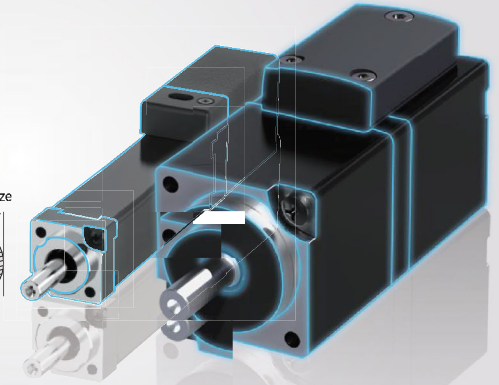

Necessary parts for miniature and high-precision equipment

For some small and high-precision intelligent equipment which needs of small frame size and high-precision, HCFA continue to increase research and development strength and investment, successfully developed the industry's smallest servo motors of SV-X6M series(14mm). Through excellent electromagnetic analysis technology, optimal structural design, first-class manufacturing technology and advanced equipment, SV-X6M series servo motors have features such as high precision, small size, high torque, low temperature rise, small inertia, and high speed, etc., to meet the needs of more compact equipment lines. HCFA has applied for a number of national patent for these servo motors.

SVX6M introduction

X6MN series servo motors are equipped with self-developed high-resolution 17-bit absolute encoders, which can meet the industry's high-precision and high-response requirements, are widely used in semiconductor manufacturing equipment (SMT mounting head, semiconductor sorting and picking Etc.), small X-Y platform devices, portable high-precision testing instruments, miniaturized medical instruments, electron microscopes, screw-locking power tools, electronic testing devices and other high-performance fields.

Product Features

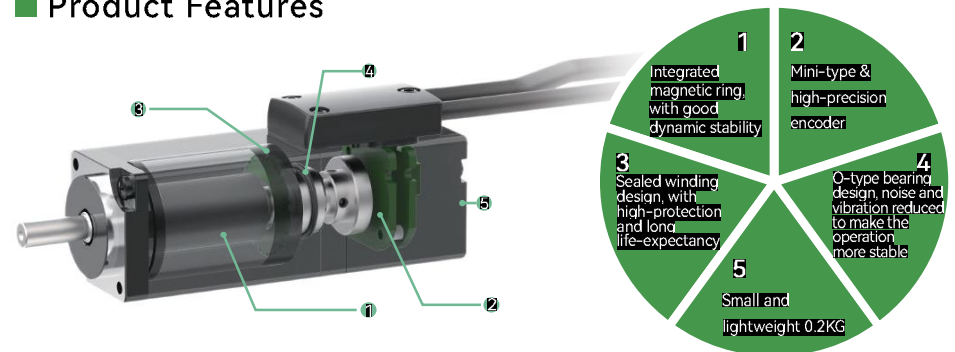

SV-X6 MN 001 A - N 6 P A **

1 2 3 4 5 6 7 8

1 Inertia spec.	
MN	Micro inertia

2 Power spec.	
0024	2.4W
001	10W
002	20W
003	30W
004	40W
005	50W

3 Flange serial No.	
A	N/A

4 Brake spec.	
N	No brake

5 Voltage spec.	
6	DC48V

6 Shaft-end spec.	
P	Optical shaft without oil seal
S	Special

7 Encoder spec.	
N	Incremental 17bit
A	Absolute 17bit

8 Customization	
**	N/A

General Specifications

Items	Specifications	Items	Specifications
Working system	S1	Thermal endurance class	F(155°C)
Vibration class	V15	Dielectric strength	AC1800V 1s(AC200V) AC600V 1s(DC48V)
Insulation resistance	DC500V,10MΩ以上	Protection level	IP 54
Ambient temperature	0~40°C	Ambient humidity	20~80%(no condensation)
Excitation method	Permanent magnetism	Connection	Shaft output
Permanent magnetism	Flange	Rotation direction	CCW viewed from the load side by forward rotation command

X6MN Performance specifications

Items	Specifications					
Voltage	DC24V/DC48V ^{*3}					
Rated power W	2.4	10	20	30	40	50
Motor models SV-X6MN00□A-N6P□	24A-N6PA 24A-N6PN	1A-N6PA 1A-N6PN	2A-N6PA 2A-N6PN	3A-N6PA 3A-N6PN	4A-N6PA 4A-N6PN	5A-N6PA 5A-N6PN
Flange size mm	14		25			
Weight kg	0.11	0.114	0.143	0.161	0.202	0.225
Rated torque N · m	0.023	0.032	0.064	0.095	0.127	0.159
Instantaneous max. torque N · m	0.06	0.096	0.192	0.287	0.381	0.477
Rated current Arms	0.6	2.04	1.82	2.7	3.64	3.02
Instantaneous max. current Arms	1.59	6.53	5.83	8.64	11.65	9.67
Rated speed min ⁻¹	1000		3000			
Max. speed min ⁻¹	1500		6000			5000
Torque constant N · m/Arms	0.043	0.016	0.037	0.038	0.038	0.056
Rotator inertia × 10 ⁻⁴ kg · m ²	0.0023	0.0044	0.0063	0.0079	0.011	0.013
Rated power change rate kW/s	2.28	2.33	6.5	11.55	14.66	19.45

▲ Note: *1 The torque-rotation speed characteristic and the combined servo drive operation are the Typ. value for the motor winding temperature at 100°C. Others are Typ. values at 20°C.

*2 The rated torque indicates the continuous allowable torque value at an ambient temperature of 40°C when mounted on an aluminum heat sink of the following size

SV-X6MN0024A-N6PA SV-X6MN001A-N6PA SV-X6MN002A-N6PA Size for aluminum heat sink:
SV-X6MN0024A-N6PN SV-X6MN001A-N6PN SV-X6MN002A-N6PN 150×150×3mm

SV-X6MN003A-N6PA SV-X6MN004A-N6PA SV-X6MN005A-N6PA Size for aluminum heat sink:
SV-X6MN003A-N6PN SV-X6MN004A-N6PN SV-X6MN005A-N6PN 250×250×6mm

*3 The torque-rotation speed characteristics can be changed according to the allowable voltage range of the servo drive main circuit.

— Continuous working range — Instantaneous working range

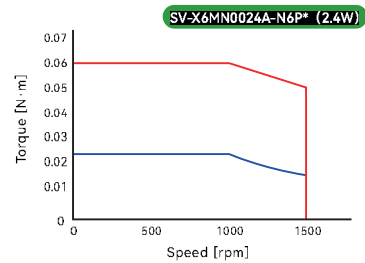
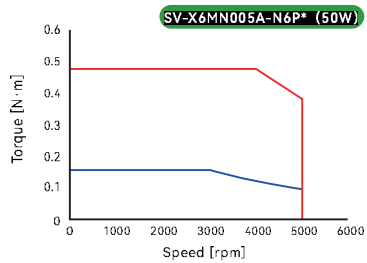
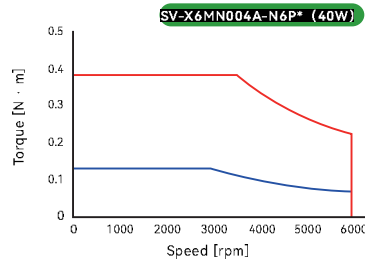
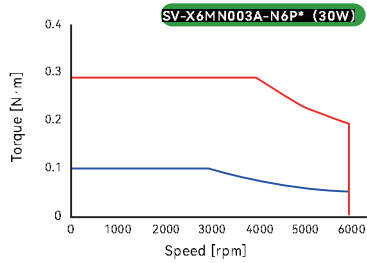
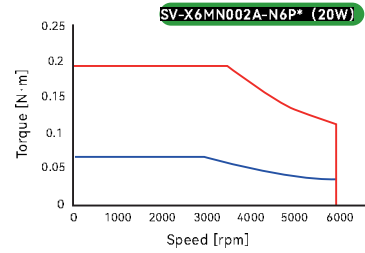
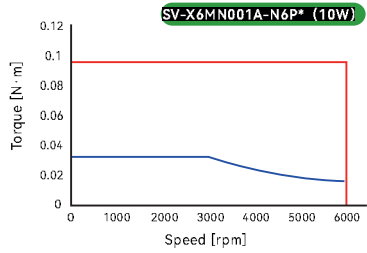

▲ Note: The characteristics may differ when applying DC48V or DC24V to the main circuit of the servo drive .

Dimensions

Models	Rated power	Variable size	
		L	KL
SV-X6MN001A-N□P□	10W	60	26
SV-X6MN002A-N□P□	20W	69	35
SV-X6MN003A-N□P□	30W	74	40
SV-X6MN004A-N□P□	40W	86	52
SV-X6MN005A-N□P□	50W	95	61

Diagram

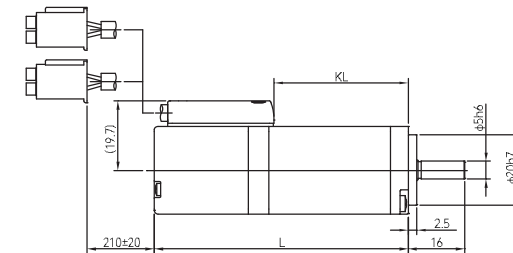
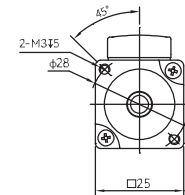

SV-X6MN0024A-N6P* (2.4W)

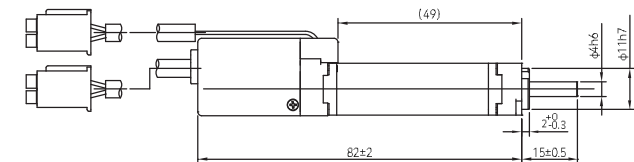
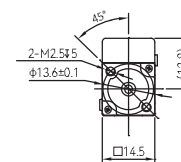

X6MN Power connector

Power side of servo motor		
Pins	Functions	Color
1	U	Red
2	V	White
3	W	Black
4	C.G	Olivine

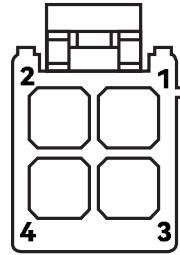

X6MN Encoder connector

Power side of servo motor		
Pins	Functions	Color
1	BATT	Green
2	+D	Yellow
3	-D	Blue
4	VCC	Red
5	GND	Grey
6	SHIELD	Black

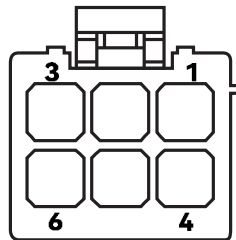

X6MN Combinations for servo drive and motor

Motor models	Voltage class	Power	Rated current	Rated torque	Recommended servo drive
SV-X6MN0024A-N6PA(N)	DC 48V	2.4W	0.6A	0.023N·M	SV-D3E*010L-E
SV-X6MN001A-N6PA(N)		10W	2.04A	0.032N·M	SV-D3E*010L-E
SV-X6MN002A-N6PA(N)		20W	1.82A	0.064N·M	SV-D3E*010L-E
SV-X6MN003A-N6PA(N)		30W	2.7A	0.095N·M	SV-D3E*010L-E
SV-X6MN004A-N6PA(N)		40W	3.64A	0.127N·M	SV-D3E*010L-E
SV-X6MN005A-N6PA(N)		50W	3.02A	0.159N·M	SV-D3E*010L-E

▲ Note: * is A: Pulse-type; B: EtherCAT type; N: CANOpen type; G: Analog type

X6MN Encoder cable

A-B:			
A-side	Color	Signal name	B-side
1	Green	BATT	4
2	Yellow	+DO	5
3	Blue	-DO	6
4	Red	VCC	1
5	Grey	GND	2
6	Black (ground-wire)	PE	Iron-shell

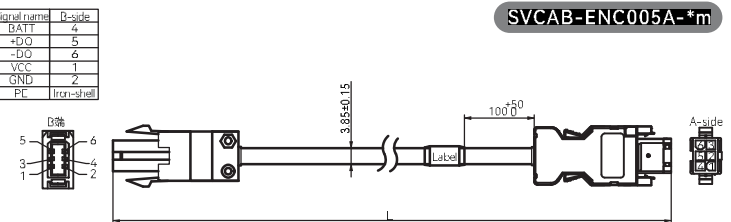

X6MN Power cable

Sequence at ①:		
No.	Wire gauge	Color
1		Red
2		White
3	AWG#24	Black
4		Olivine

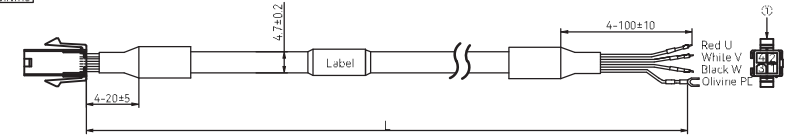

Cables	Name	Cables
Encoder cable	SVCAB-ENC005A-1.5m	28AWG
	SVCAB-ENC005A-3m	
	SVCAB-ENC005A-5m	
Power cable	CAB-PWR005A-1.5m	24AWG
	CAB-PWR005A-3m	
	CAB-PWR005A-5m	

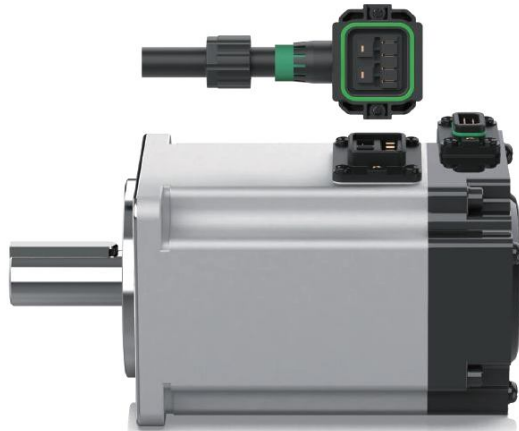

Flange for standard servo motor:
40mm 60mm 80mm

Built-in 17bit encoder, the max.
speed can reach 4500rpm

SV-X2 MA 075A N 6 L N **
1 2 3 4 5 6 7

1 Inertia spec.	
MA	Low inertia
MM	Middle inertia
MH	High inertia

2 Power spec.	
010A	100W
020A	200W
040A	400W
075A	750W

3 Brake spec.	
N	No brake
B	24V brake

4 Voltage spec.	
6	DC48V
8	DC24V

5 Shaft-end spec.	
K	Lead-wire /no oil seal
L	Lead-wire/with oil seal

6 Encoder spec.	
N	Single-turn absolute 17bit
A	Multi-turn absolute 17bit

7 Customization	
**	N/A

X2M Performance specifications (48V)

Items	Specifications			
	DC48V			
Voltage	DC48V			
Rated power W	100	200	400	750
Motor models SV-X2M□□□A□6LA	H-10A-N6LA H-10A-B6LA	A-20A-N6LA A-20A-B6LA	A-40A-N6LA A-40A-B6LA	A-75A-N6LA A-75A-B6LA
Flange size mm	40	60	60	80
Weight(no/with brake) kg	0.48/0.69	1.08/1.58	1.51/2.01	2.92/3.72
Rated torque N · m	0.32	0.64	1.27	2.39
Instantaneous max. torque N · m	0.7	1.28	3.82	7.32
Rated current Arms	3.5	8	11	21
Instantaneous max. current Arms	9	20	33	-
Rated speed min ⁻¹	3000	3000	3000	3000
Max. speed min ⁻¹	4500	4000	3500	4000
Torque constant N · m/Arms	0.09	0.101	0.132	0.119
Torque constant×10kg ⁴ · m ² (no brake)	0.092	0.17	0.35	0.988
Rotator inertia×10kg ⁴ · m ² (with brake)	0.095	0.21	0.38	1.2
Rated power change rate kW/s	12.1/-	24.6/19.8	41.4/38.4	53.6/51.2

X2M Performance specifications (24V)

Items	Specifications		
	DC24V		
Voltage	DC24V		
Rated power W	100	200	320
Motor models SV-X2M□□□A□6LA	H-10A-N8LA H-10A-B8LA	A-20A-N8LA	H-32A-N8LA
Flange size mm	40	60	60
Weight(no/with brake) kg	0.48/0.69	1.08/-	1.51/-
Rated torque N · m	0.32	0.64	1
Instantaneous max. torque N · m	0.64	1.28	2
Rated current Arms	6.6	14.5	21
Instantaneous max. current Arms	13.2	30	42
Rated speed min ⁻¹	3000	3000	3000
Max. speed min ⁻¹	4000	4500	3200
Torque constant N · m/Arms	0.05	0.046	0.06
Torque constant×10kg ⁴ · m ² (no brake)	0.092	0.17	0.73
Rotator inertia×10kg ⁴ · m ² (with brake)	0.095	-	-
Rated power change rate kW/s	12.1/-	-	22.8

— Continuous working range — Instantaneous working range

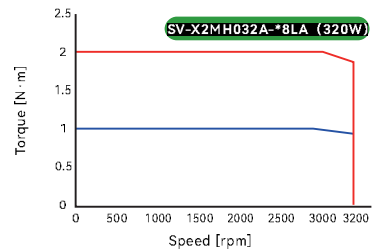
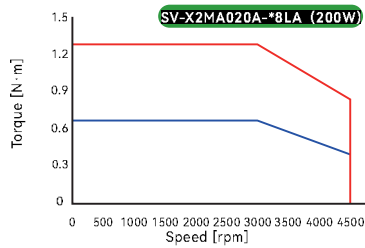
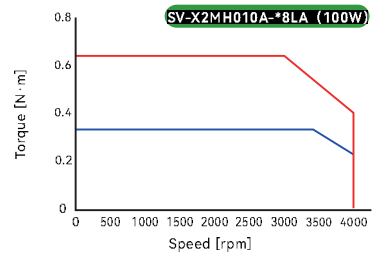
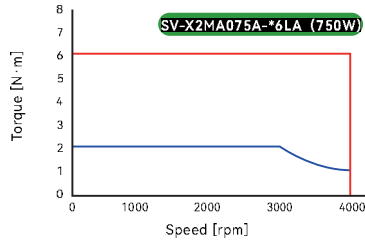
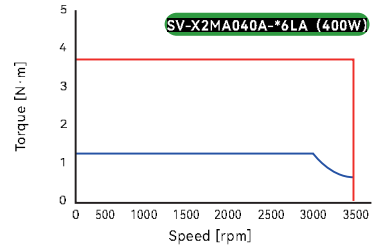
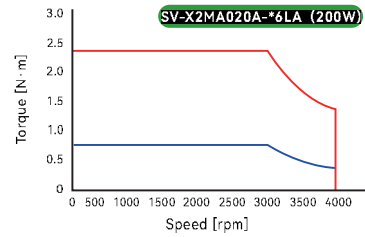
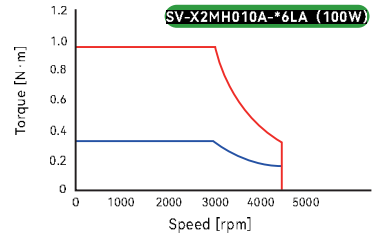

X2M Dimensions (48V)

Unit(mm)

Models	SV-X2MH010A-N6LA SV-X2MH010A-B6LA	SV-X2MA020A-N6LA SV-X2MA020A-B6LA	SV-X2MA040A-N6LA SV-X2MA040A-B6LA	SV-X2MA075A-N6LA SV-X2MA075A-B6LA
LC	40	60	60	80
LA	φ46	φ70	φ70	φ90
LB	φ30	φ50	φ50	φ70
LZ	2-φ4.3	4-φ5.5	4-φ5.5	4-φ6.6
LR	25±0.5	30±0.5	30±0.5	35±0.5
S	φ8 h6	φ14 h6	φ14 h6	φ19 h6
LL no brake [with brake]	76.7 [110.7]±1	80 [116.5]±1	119[155.5]±1	128 [165]±1
LG	5	6.5	6.5	8
LE	3	3	3	3
LH1	34.5±0.5	43±0.5	48±0.5	58±0.5
H-typecable length for lead-wire type	210±20	210±20	250±20	250±20

X2M Dimensions (24V)

Unit(mm)

Models	SV-X2MH010A-N8LA SV-X2MH010A-B8LA	SV-X2MA020A-N8LA	SV-X2MH032A-N8LA
LC	40	60	60
LA	φ46	φ70	φ70
LB	φ30	φ50	φ50
LZ	2-φ4.3	4-φ5.5	4-φ5.5
LR	25±0.5	30±0.5	30±0.5
S	φ8 h6	φ14 h6	φ14 h6
LL	76.7 [110.7]±1	80 [116.5]±1	98.6 [-]
LG	5	6.5	6.5
LE	3	3	3
LH1	34.5±0.5	48±0.5	48±0.5
H-typecable length for lead-wire type	210±20	250±20	250±20

Diagram

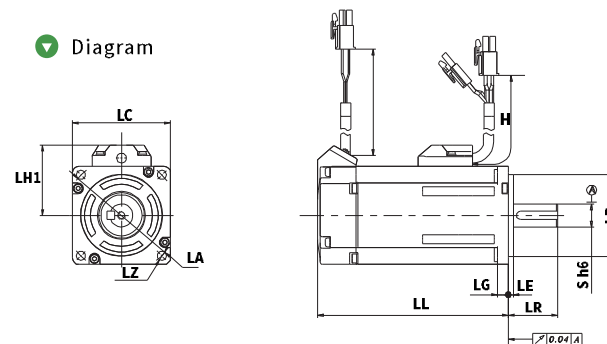

X2M Power connector

Power side of servo motor		
Pins	Functions	Color
1	U	Red
2	V	White
3	W	Black
4	C.G	Green

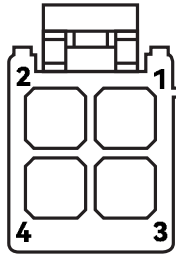

X2M Encoder connector

Power side of servo motor		
Pins	Functions	Color
1	BATT	Yellow(red marked)
2	+DO	White(red marked)
3	-DO	White(black marked)
4	VCC	Orange(red marked)
5	GND	Orange(black marked)
6	SHIELD	Black

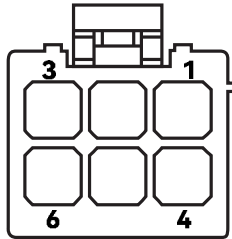

X2M Brake connector

Power side of servo motor		
Pins	Functions	Color
1	BRK1	Yellow
2	BRK2	Cyan

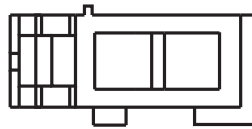

X2M Combinations for servo drive and motor

Motor models	Voltage class	Power	Rated current	Rated torque	Recommended servo drive
SV-X2MH010A-N(B)6LA	DC 48V	100W	3.5A	0.32N·M	SV-D3E*010L-E
SV-X2MA020A-N(B)6LA		200W	8A	0.64N·M	SV-D3E*020L-E
SV-X2MA040A-N(B)6LA		400W	11A	1.27N·M	SV-D3E*040L-E
SV-X2MA075A-N(B)6LA		750W	21A	2.39N·M	SV-D3E*075L-E

▲ Note: * is A: Pulse-type; B: EtherCAT type; N: CANOpen type; G: Analog type

Encoder cable(general-purpose)

Sequence at A-B:			
A-side	Wire gauge	Color	Signal name
1	AWG26	Yellow(red marked)	BATT
2		White(red marked)	+DO
3		White(black marked)	-DO
4		Orange(red marked)	VCC
5		Orange(black marked)	GND
6		Weave	Iron-shell

SVCAB-ENC75A-*M

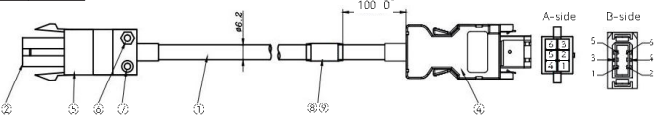

X2M Power cable(100~200W models)

Sequence at ①:		
No.	Wire gauge	Color
1		Red
2	AWG20	White
3		Black
4		Yellow/green

CAB-PWR75A-*M

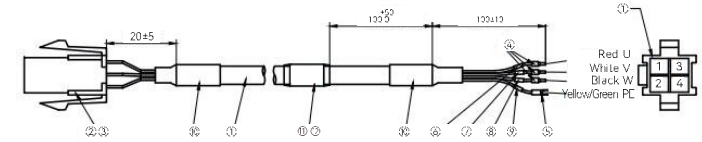

X2M Power cable(for 400 ~750W models)

Sequence at ①:		
No.	Wire gauge	Color
1		Red
2	AWG13	White
3		Black
4		green

CAB-PWR75A-*M-48V

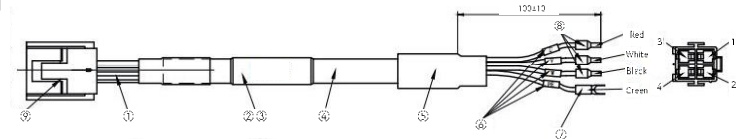

X2M Power brake cable(for 100~200W models)

Sequence at ①:		
No.	Wire gauge	Color
1		Red
2	AWG20	White
3		Black
4		Yellow/green

CAB-PWB75A-*M

Sequence at ②:		
No.	Wire gauge	Color
1		Orange
2	AWG22	Brown

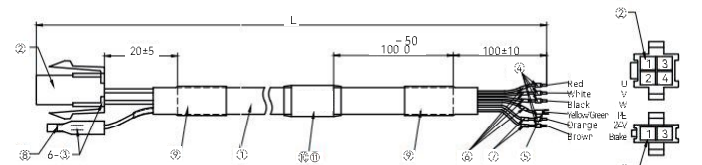

X2M Power brake cable(for 400~750W models)

Sequence at ①:		
No.	Wire gauge	Color
1		Red
2	AWG13	White
3		Black
4		Green
5	AWG23	Orange/yellow
6		Brown/cyan

CAB-PWB75A-*M-48V

