

CONTENTS

㉠ Linear Rail System

• Technical Data	㉠/4
• The Types of Linear Rail System	㉠/46
• SBI High-load Linear Rail System	㉠/48
SBI-FL/FLL	㉠/68
SBI-SL/SLL	㉠/70
SBI-HL/HLS/HLL	㉠/72
SBI-CL/CLS/CLL	㉠/74
SBI-FV	㉠/76
SBI-SV	㉠/78
• SBG Standard Linear Rail System	㉠/80
SBG-FL/FLL	㉠/100
SBG-SL/SLL	㉠/102
SBS-SL/SLL/HL/HLL	㉠/104
SBS-FV	㉠/106
SBS-SV	㉠/108
• SPG / SPS Spacer Linear Rail System	㉠/110
SPG-FL/FLL	㉠/112
SPG-SL/SLL	㉠/114
SPS-SL/SLL/HL/HLL	㉠/116
SPS-FV	㉠/118
SPS-SV	㉠/120
• Miniature Linear Rail System	㉠/122
SBM/SBML	㉠/132
SBMW	㉠/134

㉡ Ball Screw

• Technical Data	㉡/2
• SBC Precision Rolled Ball Screw	㉡/46
STK/STC	㉡/50
SLK	㉡/52
MBS	㉡/54
• DIN Standard SBC Precision Rolled Ball Screw	㉡/56
DK	㉡/60
DH	㉡/62
• Ground Ball Screw for FA- SFA Series	㉡/64

㉢ Support Unit

• Fixed-End Support Unit	㉢/2
FK	㉢/4
FK-DS(T)	㉢/6
BK	㉢/8
BK-DS	㉢/10
EK	㉢/12
AK	㉢/14
• Supported-End Support Unit	㉢/16
FF	㉢/18
FF-DS(T)	㉢/20
BF	㉢/22
BF-DS	㉢/24
EF	㉢/26
AF	㉢/28
• Recommended Screw End Machining	㉢/30

㉣ Linear Bushings

• Technical Data	㉣/2
• Asia type Ball Bushing	㉣/18
SB, SB-L, SB-AJ, SB-OP	㉣/20~27
SBF, SBF-L	㉣/28~31
SBK, SBK-L	㉣/32~35
SBH, SBH-L	㉣/36~39
SBF-A, SBF-LA	㉣/40~43
SBK-A, SBK-LA	㉣/44~47
SBH-A, SBH-LA	㉣/48~51
SBFC, SBKC, SBHC	㉣/52~57
SC, SC-L	㉣/58~61
• Europe type Ball Bushing	㉣/62
SBE, SBE-L, SBE-AJ, SBE-OP	㉣/64~71
SBFE, SBFE-L	㉣/72~75
SBKE, SBKE-L	㉣/76~79
SBFCE, SBKCE	㉣/80~83
SCE, SCE-L	㉣/84~87
• Compact type Ball Bushing / Option	㉣/88
KH	㉣/89
SK	㉣/90
SHF	㉣/91

㉔ Cross Roller Guide

• Technical Data	㉔/2
• Cross Roller Guide SCVR Type	㉔/8
SCVR 1	㉔/18
SCVR 2	㉔/20
SCVR 3	㉔/22
SCVR 4	㉔/24
SCVR 6	㉔/26
SCVR 9	㉔/28
• Cross Roller Table SCVRT Type, SCVRU Type	㉔/30
SCVRT 1	㉔/34
SCVRT 2	㉔/36
SCVRT 3	㉔/38
SCVRT 1-A	㉔/40
SCVRT 2-A	㉔/42
SCVRT 3-A	㉔/44
SCVRU 1	㉔/46
SCVRU 2	㉔/48
SCVRU 3	㉔/50
SCVRU 4	㉔/52
SCVRU 6	㉔/54
SCVRU 9	㉔/56

㉕ Robot Carrier Guide

• Technical Data	㉕/2
• Carriage (3 rollers)	㉕/12
723X	㉕/12
• Carriage (4 rollers)	㉕/14
724X	㉕/14
• Carriage Option	㉕/16
• Flat Rail	㉕/18
F308	㉕/18
F312	㉕/19
• Rack Rail	㉕/20
R308	㉕/20
R312	㉕/21



Linear Rail System

Technical Data / The Types of Linear Rail System / SBI High-load Linear Rail System /
SBG Standard Linear Rail System / SPG, SPS Spacer Linear Rail System /
Miniature Linear Rail System

Linear Rail System

Technical Data

SBC LINEAR RAIL SYSTEM FEATURES

- Circular-Arc raceway structure achieves the high rigidity and large permissible load.
- Four row circular arc groove with 2 points contact creates the same load in all directions.
- DF structure maintains low instrumental errors.
- Low frictional coefficient achieves the high energy efficiency.
- Easy maintenance.
- Improve the productivity of the machine.
- Various options, Easy machine design and Longer life span.

Comparison the Linear Rail System with others

Item	Linear Rail System	Plane Ball System	Sliding Friction Guide
Assembly	Self-adjusting	△	Additional working need
Precision	Absorbing errors	X	Machining necessary
Maintenance	Various grease feeding	○	Hard to grease feeding
Sway	○	○	X
Impact	○	Low rating load	○
Moment	High rating load	Low rating load	Vulnerable to eccentric load

Linear Rail System

Technical Data

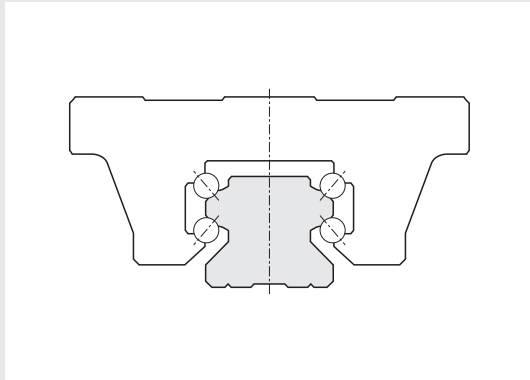

DF Structure

DF structure maintains low instrumental errors.

Applied model : SBI, SBG, SBS, SPG, SPS

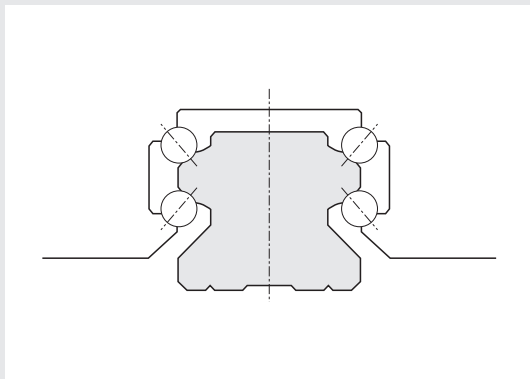

The Structure of Raceway Groove and Ball Contact

Circular-Arc Groove, Four Raceway, Two-Point Contact Structure absorb the instrumental errors and create smooth movement even under high load operation.

Applied Model : SBI, SBG, SBS, SPG, SPS

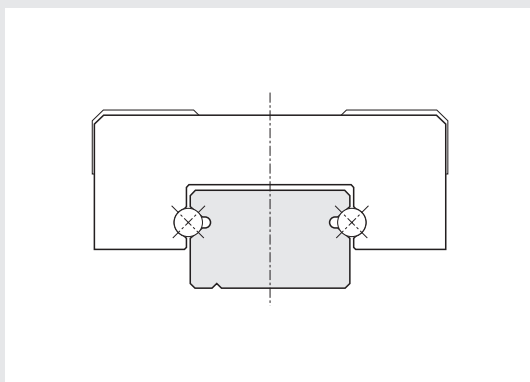

Gothic-Arch Groove, Two Row, Four Point Contact Structure is not effective for absorbing errors but it is optimized for miniaturized machine which is necessary for smooth movement under high load condition.

Applied Model: SBM, SBML, SBMW

㉓ Linear Rail System

㉔ Ball Screw

㉕ Support Unit

㉖ Linear Ball Bush

㉗ Cross Roller Guide

㉘ Robot Carrer Guide

Memo

Linear Rail System

Technical Data

Load Rating & Life

Under normal conditions, the linear rail system can be damaged by metal fatigue as the result of repeated stress. The repeated stress causes flaking of the raceways and steel balls. The life of linear rail system is defined as the total travel distance that the linear rail system travels until flaking occurs.

Nominal Life : L (km)

We define the nominal life as the total distance of travel (L=km) without flaking by 90% of a group of an identical group of linear rail systems operating under the same condition.

[In case of ball]

$$L = \left(\frac{C}{P} \right)^3 \times 50\text{km}$$

- L : Nominal life
- P : Pay load
- C : Basic dynamic load rating

[In case of roller]

$$L = \left(\frac{C}{P} \right)^{\frac{10}{3}} \times 100\text{km}$$

Basic Dynamic Load Rating : C (kN)

The basic dynamic load rating C is a statistical number and it is based on 90% of the bearings surviving 50Km of travel carrying the full load.

Basic Static Load Rating : Co (kN)

If an excessive load or shock is applied to the linear rail system in the static or dynamic state, permanent but local deformation can occur to the steel balls and raceway. The Basic Static Load Rating is the maximum load the bearing can accept without affecting the dynamic life. This value is usually associated with a permanent deformation of the race way surface of 0.0001 time the ball diameter

Linear Rail System

Technical Data

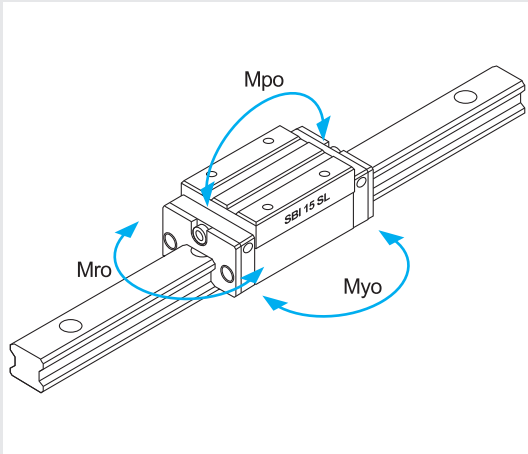

Static Permissible Moment : Mo (kN.m)

These load are maximum moments or torque loads that can be applied to the bearing without damaging the bearing or affecting subsequent dynamic life.

- Mro : Moment in rolling direction
- Mpo : Moment in pitching direction
- Myo : Moment in yawing direction

Static Safety Factor : fs

When calculating a load exerted on the linear rail system, both mean load and maximum load need to be considered. Reciprocating machines create moment of inertia. When selecting the right linear rail system, consider all of the loads.

- Co : Basic Static Load Rating
- P : Pay Load
- Mo : Static Permissible Moment (Mpo, Mro, Myo)
- M : Pay Load Moment

$$f_s = \frac{C_o}{P} \quad (\text{Radial Load})$$

$$f_s = \frac{M_o}{M} \quad (\text{Moment Load})$$

(Table, Static Safety Factor)

Operating	Load conditions	fs
Normally stationary	Impact load or machine deflection is small	1.0 ~ 1.3
	Impact or twisting load is applied	2.0 ~ 3.0
Normally moving	Normal load is exerted or machine deflection is small	1.0 ~ 1.5
	Impact or twisting load is applied	2.5 ~ 7.0

Linear Rail System

Technical Data

Frictional Resistance

The static and dynamic coefficient of friction of the SBC linear rail systems are so small that they minimize the required driving force and temperature increase. Frictional force depends on load, preload, velocity and lubrication. In general, the light load with high speed is more affected by the lubricant, while the medium or heavy load are more affected by the load and are less sensitive to lubrication selection.

*Coefficient of friction for linear rail system(μ) : 0.002~0.004

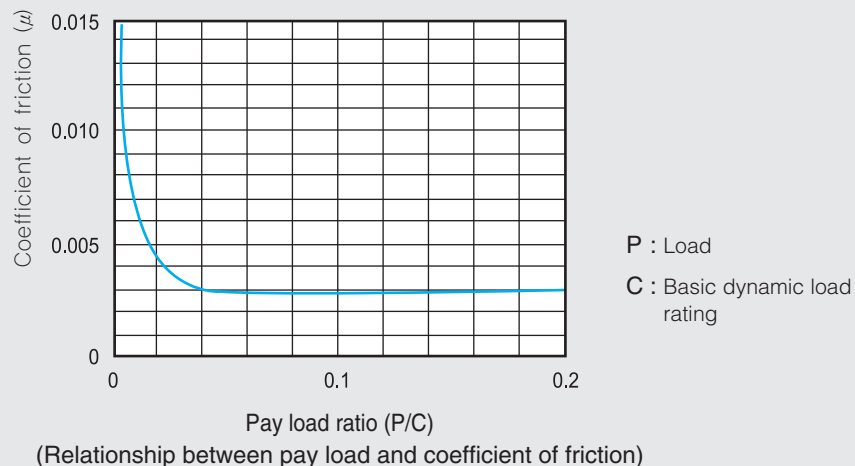

Calculate comparison by different guide system

$$F = \mu \cdot P$$

- F : Frictional force
- μ : Coefficient of friction
- P : Load

(1) Linear rail system

P : 5000N

μ : 0.003

F = 0.003 x 5000N = **15N**

(2) Sliding linear rail system

P : 5000N

μ : 0.2

F = 0.2 x 5000N = **1000N**

Linear Rail System

Technical Data

The procedure of selecting linear rail system

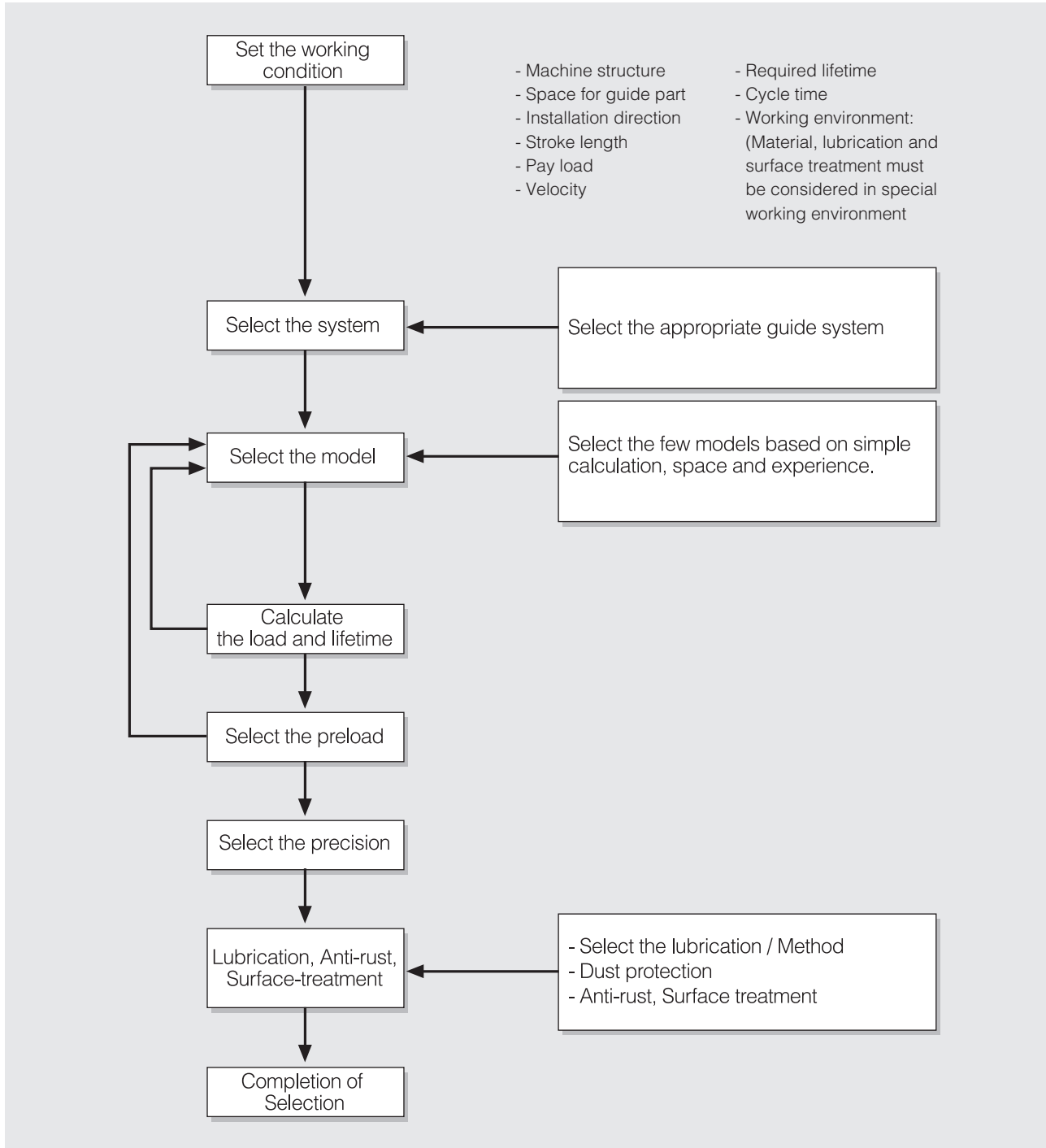

㉓ Linear Rail System

㉔ Ball Screw

㉕ Support Unit

㉖ Linear Ball Bush

㉗ Cross Roller Guide

㉘ Robot Carrer Guide

Memo

Linear Rail System

Technical Data

Select the system / Model

1. Select System

Select the appropriate guide system after considering rigidity, cost of machine and manufacturing time.

2. Select Model

Select the few models based on simple calculation, space and experience.

3. Calculate the load and life time

Judge the expected life time after calculating the load and life time and apply the model to machine design.

3-1. Calculating the applied loads

Loads exerted on a linear rail system vary according to direction. It is important to consider this condition before selecting the type of linear rail systems and model. Refer to the below example when calculating the loads.

[Condition of calculating the applied load]

Select the few models after considering space and experience and simple calculation for working conditions.

- m (kg) : Load
- l_n (mm) : Distance(mm)
- P_n : Radial load
- P_{nT} : Lateral load
- g (m/s^2) : Gravitational acceleration (= $9.8 m/s^2$)
- V (m/s) : Velocity
- a_n (m/s^2) : Acceleration

Linear Rail System

Technical Data

Calculating the applied loads and life time

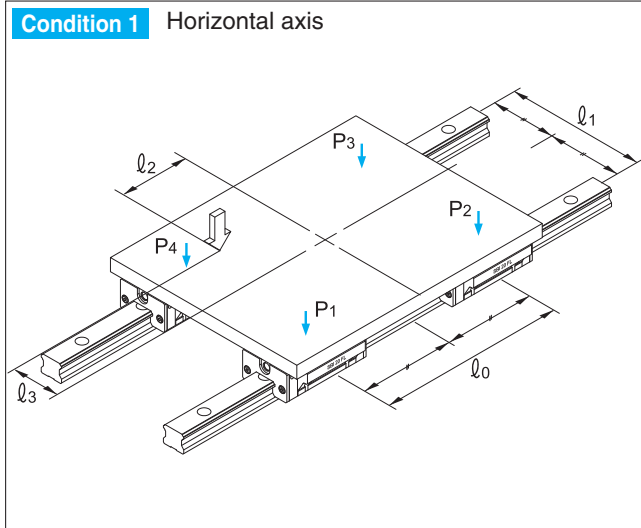

$$P_1 = \frac{mg}{4} + \frac{mg \cdot l_2}{2 \cdot l_0} - \frac{mg \cdot l_3}{2 \cdot l_1}$$

$$P_2 = \frac{mg}{4} - \frac{mg \cdot l_2}{2 \cdot l_0} - \frac{mg \cdot l_3}{2 \cdot l_1}$$

$$P_3 = \frac{mg}{4} - \frac{mg \cdot l_2}{2 \cdot l_0} + \frac{mg \cdot l_3}{2 \cdot l_1}$$

$$P_4 = \frac{mg}{4} + \frac{mg \cdot l_2}{2 \cdot l_0} + \frac{mg \cdot l_3}{2 \cdot l_1}$$

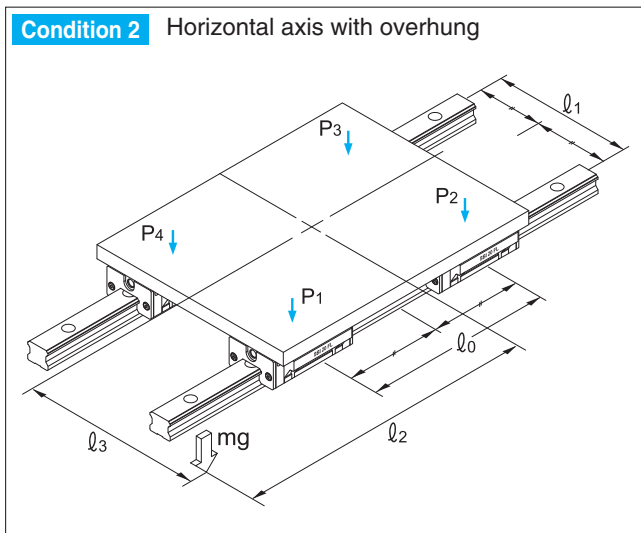

$$P_1 = \frac{mg}{4} + \frac{mg \cdot l_2}{2 \cdot l_0} + \frac{mg \cdot l_3}{2 \cdot l_1}$$

$$P_2 = \frac{mg}{4} - \frac{mg \cdot l_2}{2 \cdot l_0} + \frac{mg \cdot l_3}{2 \cdot l_1}$$

$$P_3 = \frac{mg}{4} - \frac{mg \cdot l_2}{2 \cdot l_0} - \frac{mg \cdot l_3}{2 \cdot l_1}$$

$$P_4 = \frac{mg}{4} + \frac{mg \cdot l_2}{2 \cdot l_0} - \frac{mg \cdot l_3}{2 \cdot l_1}$$

Ⓐ Linear Rail System

Ⓑ Ball Screw

Ⓒ Support Unit

Ⓓ Linear Ball Bush

Ⓔ Cross Roller Guide

Ⓕ Robot Carrer Guide

Memo

Linear Rail System

Technical Data

Condition 3 Vertical axis

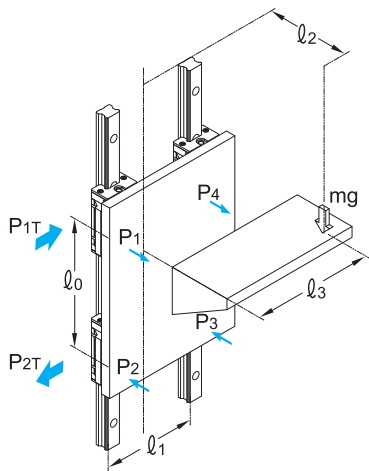

$$P_1 - P_4 = \frac{mg \cdot l_2}{2 \cdot l_0}$$

$$P_{1T} - P_{4T} = \frac{mg \cdot l_3}{2 \cdot l_0}$$

Condition 4 Vertical axis with wall mounted

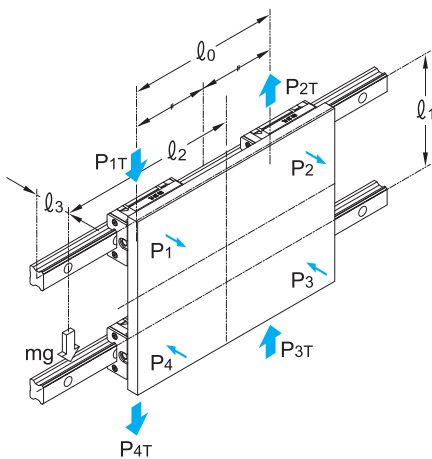

$$P_1 - P_4 = \frac{mg \cdot l_3}{2 \cdot l_1}$$

$$P_{1T} - P_{4T} = \frac{mg}{4} + \frac{mg \cdot l_2}{2 \cdot l_0}$$

$$P_{2T} - P_{3T} = \frac{mg}{4} - \frac{mg \cdot l_2}{2 \cdot l_0}$$

Linear Rail System

Technical Data

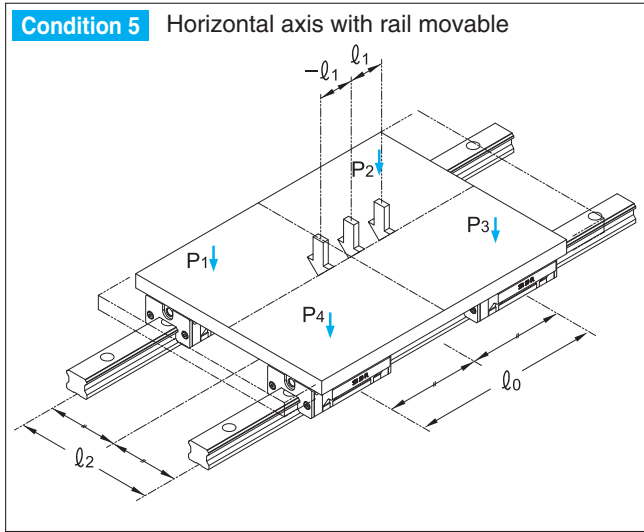

$$P_1 - P_{4(max)} = \frac{mg}{4} + \frac{mg \cdot l_1}{2 \cdot l_0}$$

$$P_1 - P_{4(min)} = \frac{mg}{4} - \frac{mg \cdot l_1}{2 \cdot l_0}$$

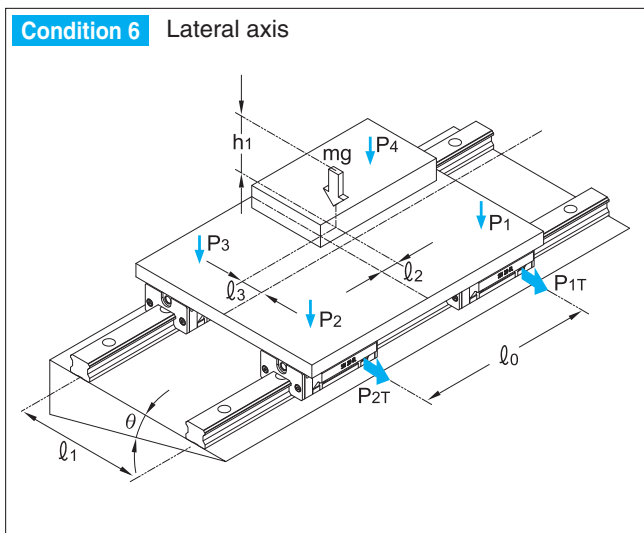

$$P_1 = \frac{mg \cdot \cos\theta}{4} + \frac{mg \cdot \cos\theta \cdot l_2}{2 \cdot l_0} - \frac{mg \cdot \cos\theta \cdot l_3}{2 \cdot l_1} + \frac{mg \cdot \sin\theta \cdot h_1}{2 \cdot l_1}$$

$$P_{1T} = \frac{mg \cdot \sin\theta}{4} + \frac{mg \cdot \sin\theta \cdot l_2}{2 \cdot l_0}$$

$$P_2 = \frac{mg \cdot \cos\theta}{4} - \frac{mg \cdot \cos\theta \cdot l_2}{2 \cdot l_0} - \frac{mg \cdot \cos\theta \cdot l_3}{2 \cdot l_1} + \frac{mg \cdot \sin\theta \cdot h_1}{2 \cdot l_1}$$

$$P_{2T} = \frac{mg \cdot \sin\theta}{4} - \frac{mg \cdot \sin\theta \cdot l_2}{2 \cdot l_0}$$

$$P_3 = \frac{mg \cdot \cos\theta}{4} - \frac{mg \cdot \cos\theta \cdot l_2}{2 \cdot l_0} + \frac{mg \cdot \cos\theta \cdot l_3}{2 \cdot l_1} - \frac{mg \cdot \cos\theta \cdot h_1}{2 \cdot l_1}$$

$$P_{3T} = \frac{mg \cdot \sin\theta}{4} + \frac{mg \cdot \sin\theta \cdot l_2}{2 \cdot l_0}$$

$$P_4 = \frac{mg \cdot \cos\theta}{4} + \frac{mg \cdot \cos\theta \cdot l_2}{2 \cdot l_0} + \frac{mg \cdot \cos\theta \cdot l_3}{2 \cdot l_1} - \frac{mg \cdot \sin\theta \cdot h_1}{2 \cdot l_1}$$

$$P_{4T} = \frac{mg \cdot \sin\theta}{4} + \frac{mg \cdot \sin\theta \cdot l_2}{2 \cdot l_0}$$

Ⓐ Linear Rail System

Ⓑ Ball Screw

Ⓒ Support Unit

Ⓓ Linear Ball Bush

Ⓔ Cross Roller Guide

Ⓕ Robot Carrier Guide

Memo

Linear Rail System

Technical Data

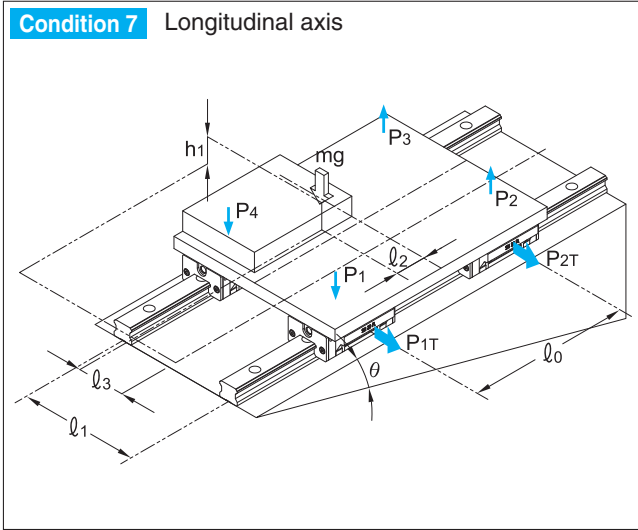

$$P_1 = \frac{mg \cdot \cos\theta}{4} + \frac{mg \cdot \cos\theta \cdot l_2}{2 \cdot l_0} - \frac{mg \cdot \cos\theta \cdot l_3}{2 \cdot l_1} + \frac{mg \cdot \sin\theta \cdot h_1}{2 \cdot l_0}$$

$$P_{1T} = \frac{mg \cdot \cos\theta \cdot l_3}{2 \cdot l_0}$$

$$P_2 = \frac{mg \cdot \cos\theta}{4} - \frac{mg \cdot \cos\theta \cdot l_2}{2 \cdot l_0} - \frac{mg \cdot \cos\theta \cdot l_3}{2 \cdot l_1} - \frac{mg \cdot \sin\theta \cdot h_1}{2 \cdot l_0}$$

$$P_{2T} = \frac{mg \cdot \sin\theta \cdot l_3}{2 \cdot l_0}$$

$$P_3 = \frac{mg \cdot \cos\theta}{4} - \frac{mg \cdot \cos\theta \cdot l_2}{2 \cdot l_0} + \frac{mg \cdot \cos\theta \cdot l_3}{2 \cdot l_1} - \frac{mg \cdot \sin\theta \cdot h_1}{2 \cdot l_0}$$

$$P_{3T} = \frac{mg \cdot \sin\theta \cdot l_3}{2 \cdot l_0}$$

$$P_4 = \frac{mg \cdot \cos\theta}{4} + \frac{mg \cdot \cos\theta \cdot l_2}{2 \cdot l_0} + \frac{mg \cdot \cos\theta \cdot l_3}{2 \cdot l_1} + \frac{mg \cdot \sin\theta \cdot h_1}{2 \cdot l_0}$$

$$P_{4T} = \frac{mg \cdot \sin\theta \cdot l_3}{2 \cdot l_0}$$

Linear Rail System

Technical Data

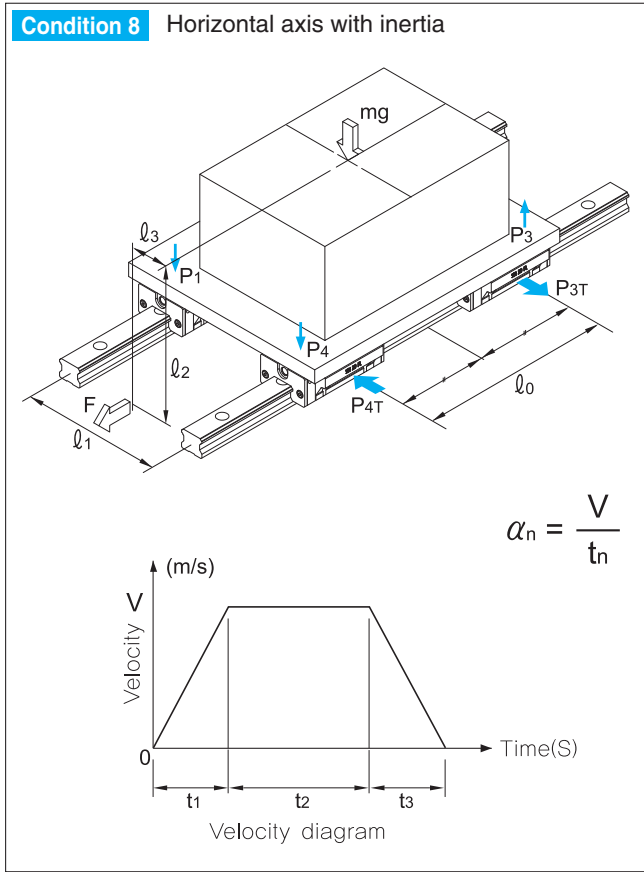

Acceleration

$$P_1 = P_4 = \frac{mg}{4} - \frac{m \cdot \alpha_1 \cdot l_2}{2 \cdot l_0}$$

$$P_2 = P_3 = \frac{mg}{4} + \frac{m \cdot \alpha_1 \cdot l_2}{2 \cdot l_0}$$

$$P_{1T} = P_{4T} = \frac{m \cdot \alpha_1 \cdot l_3}{2 \cdot l_0}$$

In uniform motion

$$P_{1T} = P_{4T} = \frac{mg}{4}$$

Deceleration

$$P_1 = P_4 = \frac{mg}{4} + \frac{m \cdot \alpha_3 \cdot l_2}{2 \cdot l_0}$$

$$P_2 = P_3 = \frac{mg}{4} - \frac{m \cdot \alpha_3 \cdot l_2}{2 \cdot l_0}$$

$$P_{1T} = P_{4T} = \frac{m \cdot \alpha_3 \cdot l_3}{2 \cdot l_0}$$

Ⓐ Linear Rail System

Ⓑ Ball Screw

Ⓒ Support Unit

Ⓓ Linear Ball Bush

Ⓔ Cross Roller Guide

Ⓕ Robot Carrer Guide

Memo

Linear Rail System

Technical Data

3-2. Calculating the Equivalent Load

Linear Rail Systems can accept normal and moment (M_{ro} , M_{po} , M_{yo}) loads in all directions including radial, reverse-radial and lateral loads at the same time. Therefore, calculate the equivalent load accordingly.

$$P_E \text{ (Equivalent load)} = P_n + P_{nT}$$

P_n : Vertical load
 P_{nT} : Horizontal load

P_n	Radial load	M_{ro}	Moment in rolling direction
P_L	Reverse-radial load	M_{po}	Moment in pitching direction
P_{nT}	Lateral load	M_{yo}	Moment in yawing direction

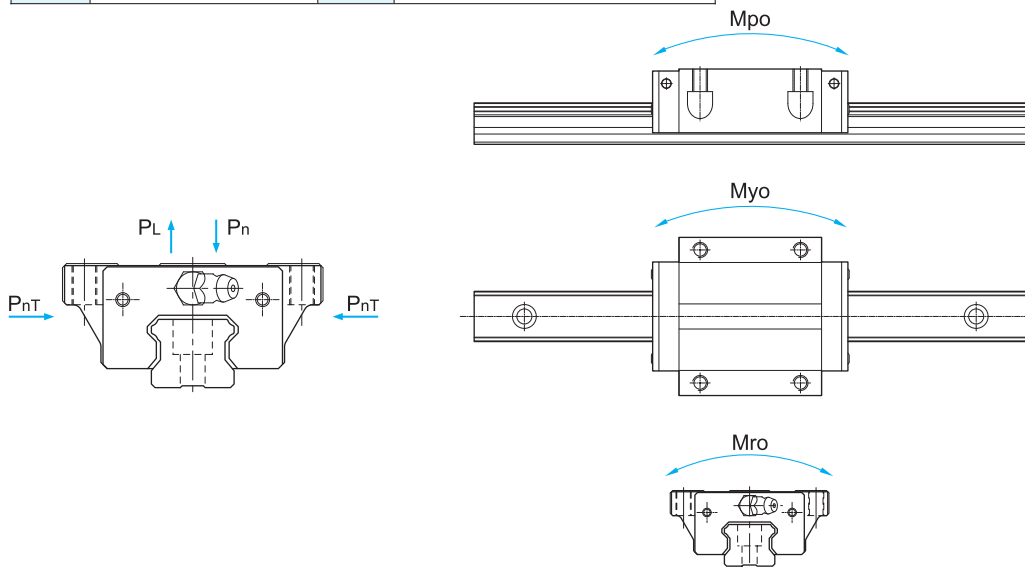

Linear Rail System

Technical Data

3-3. Static Safety Factors (fs)

When calculating a load exerted on the linear rail system, both mean and maximum load need to be considered. Reciprocating machines create moment of inertia. When selecting the right linear rail system, consider all of loads.

Radial load is large	$\frac{f_H \cdot f_T \cdot f_C \cdot C_o}{P_n} \geq f_s$
Reverse-radial load is large	$\frac{f_H \cdot f_T \cdot f_C \cdot C_{OL}}{P_L} \geq f_s$
laterall load is large	$\frac{f_H \cdot f_T \cdot f_C \cdot C_{OT}}{P_{nT}} \geq f_s$

- fs : Static safety factor
- Co(N) : Basic static load rating (radial)
- CoL(N) : Basic static load rating (reverse-radial)
- CoT(N) : Basic static load rating (lateral)
- Pn(N) : Calculated load (radial)
- PL(N) : Calculated load (reverse-radial)
- PnT(N) : Calculated load (lateral)
- fH : Hardness factor
- fT : Temperature factor
- fC : Contact factor

[Value of static safety factor (fs)]

Operating	Load conditions	Lower limit of fs
Normally stationary	Impact load or machine deflection is small	1.0 ~ 1.3
	Impact or twisting load is applied	2.0 ~ 3.0
Normally moving	Normal load is exerted or machine deflection is small	1.0 ~ 1.5
	Impact or twisting load is applied	2.5 ~ 7.0

③ Linear Rail System

④ Ball Screw

⑤ Support Unit

⑥ Linear Ball Bush

⑦ Cross Roller Guide

⑧ Robot Carrer Guide

Memo

Linear Rail System

Technical Data

3-4. Calculating the Mean Load

Loads acting on a linear rail system can vary according to various conditions. All load conditions must be taken into consideration in order to calculate the required linear rail system capacity

[Equation for calculating the mean load]

- P_m : Mean load (N)
- P_n : Varying load (N)
- L : Total length of travel (mm)
- L_n : Length of travel carrying P_n (mm)

$$P_m = \sqrt[3]{\frac{1}{L} \cdot \sum_{m=1}^n (P_n^3 \cdot L_n)}$$

1) Step loads

$$P_m = \sqrt[3]{\frac{1}{L} (P_1^3 \cdot L_1 + P_2^3 \cdot L_2 + \dots + P_n^3 \cdot L_n)} \dots (1)$$

- P_m : Mean load (N)
- P_n : Varying load (N)
- L : Total length of travel (mm)
- L_n : Length of travel carrying P_n (mm)

2) Loads that vary linearly

$$P_m \doteq \frac{1}{3} (P_{min} + 2 \cdot P_{max}) \dots (2)$$

- P_{min} : Minimum load (N)
- P_{max} : Maximum load (N)

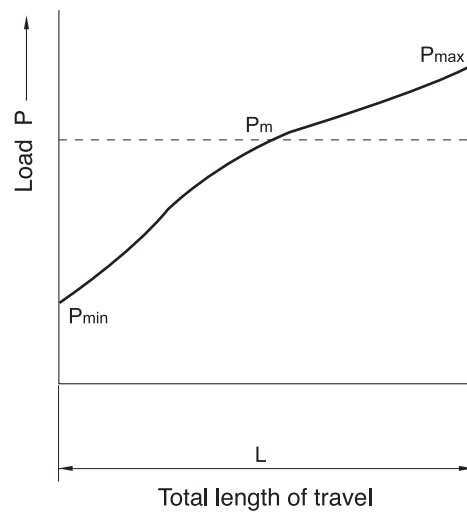
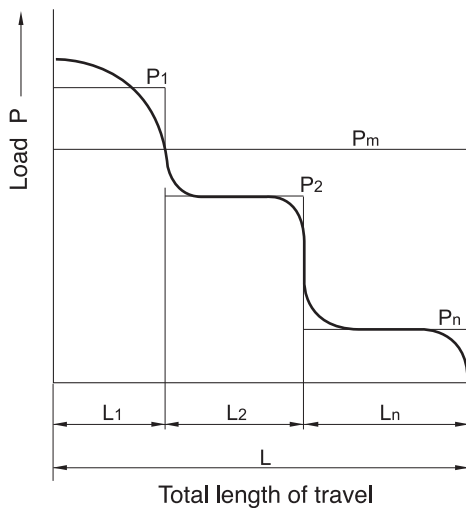

Linear Rail System

Technical Data

3) Loads varying sinusoidally

a) $P_m \doteq 0.65_{max}$ (3)

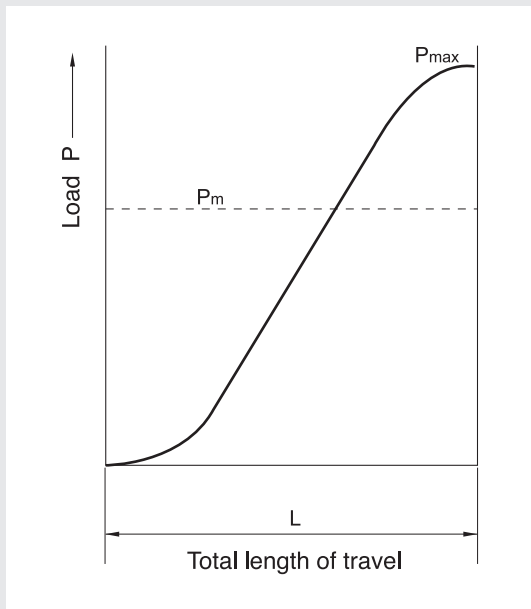

b) $P_m \doteq 0.75_{max}$ (4)

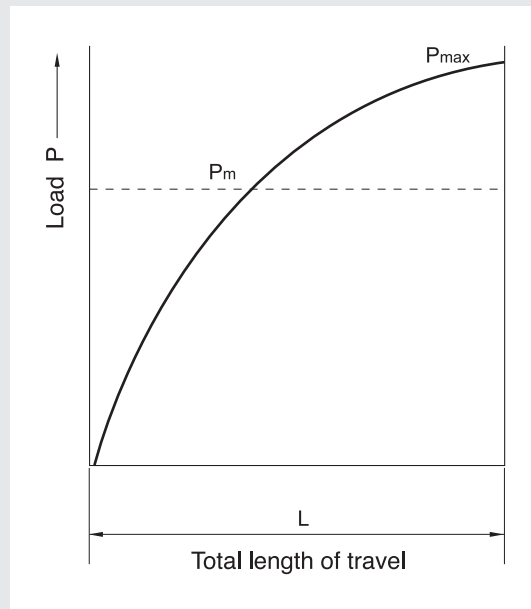

㉓ Linear Rail System

㉔ Ball Screw

㉕ Support Unit

㉖ Linear Ball Bush

㉗ Cross Roller Guide

㉘ Robot Carrer Guide

Memo

Linear Rail System

Technical Data

3-5. Life Calculation

The equation of nominal life for linear rail system is shown as below.

[Calculation of nominal life]

$$L = \left(\frac{f_H \cdot f_T \cdot f_C}{f_W} \cdot \frac{C}{P_C} \right)^3 \times 50$$

- L (km) : Nominal life
- P_C(N) : Calculated load
- C (N) : Basic dynamic load rating
- f_H : Hardness factor
- f_T : Temperature factor
- f_C : Contact factor
- f_W : Load factor

Hardness factor (f_H)

To optimize the load capacity of a linear rail system, the hardness of the rail should be HRC 58~62.

※ The value for linear rail system is normally 1.0 since the linear rail system has sufficient hardness.

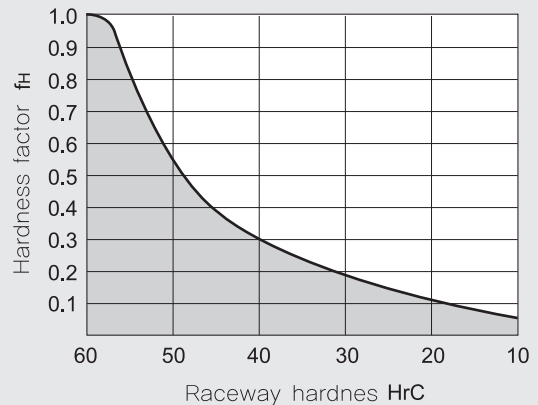

Temperature factor (f_T)

If the temperature of the linear rail system is over 100°C, The hardness of the block and rail will be reduced, and as the result, the temperature factor, f_T should be taken into Account.

- ※ The value for linear rail system is normally 1.0 when operation temperature is under 80°C.
- ※ Please contact us if you need linear rail system with over 80°C working condition.

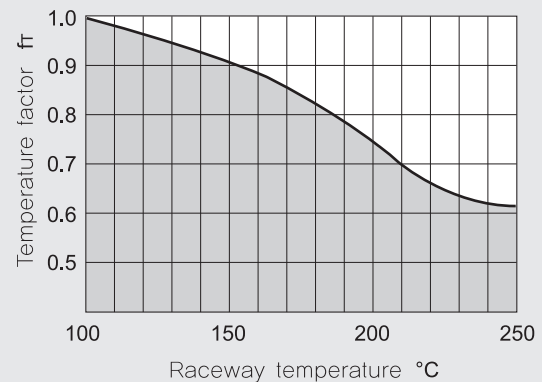

Linear Rail System

Technical Data

Contact factor (fc)

When two or more blocks are used in close contact, it is hard to obtain a uniform load distribution because of mounting errors and tolerances. The basic dynamic load C should be multiplied by the contact factors fc shown here.

Number of blocks in close contact	Contact factor fc
2	0.81
3	0.72
4	0.66
5	0.61
6 or more	0.6
Normal condition	1.0

Load factor (fw)

Reciprocating machines create vibrations. The effects of vibrations are difficult to calculate precisely. Refer to the following table to compensate for these vibrations.

Vibration and Impact	Velocity (V)	Load factor fw
Very slight	Very low $V \leq 0.25\text{m/s}$	1 ~ 1.2
Slight	Low $0.25 < V \leq 1.0\text{m/s}$	1.2 ~ 1.5
Moderate	Medium $1.0 < V \leq 2.0\text{m/s}$	1.5 ~ 2.0
Strong	High $V < 2.0\text{m/s}$	2.0 ~ 3.5

[Life calculation]

When the nominal life (L) is calculated. The life of linear rail system can be calculated by following equation, if the stroke and reciprocating cycles per minute are constant.

- L_h (h) : Hours of nominal life
- L (km) : Nominal life
- l_s (mm) : Stroke
- n_1 (min^{-1}) : Reciprocation cycles per minute

$$L_h = \frac{L \times 10^6}{2 \times l_s \times n_1 \times 60}$$

① Linear Rail System

② Ball Screw

③ Support Unit

④ Linear Ball Bush

⑤ Cross Roller Guide

⑥ Robot Carrier Guide

Memo

Linear Rail System

Technical Data

4. Rigidity

4-1. Radial-Clearance

The block side to side movement by vibration is called clearance.

Clearance checking

After mounting the linear rail system, move the block up and down then check the change of value.

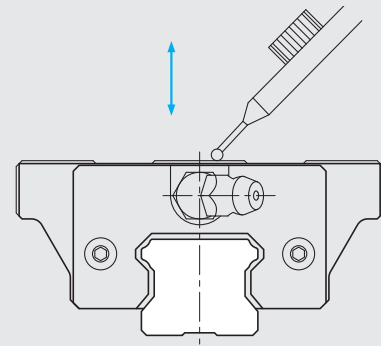

4-2. Preload

Preload affects the rigidity, internal-load and clearance. Also, it is very important to select appropriate preload according to applied load, impact and vibration expected in the application.

Preload	Conditions	Example
K3 [Heavy preload]	<input type="checkbox"/> Where rigidity is required, vibration and impact are present. <input type="checkbox"/> Engineered machinery for heavy equipment	<ul style="list-style-type: none"> ● Machining center ● NC lathe ● Grinding machine ● Milling machine ● Vertical axis of machine tool
K2 [Light preload]	<input type="checkbox"/> Where overhung loads or moment occur <input type="checkbox"/> Single axis operation. <input type="checkbox"/> Light load that requires precision.	<ul style="list-style-type: none"> ● Measuring equipment ● Electric discharge machine ● High speed material handling equipment ● NC drilling machine ● Industrial robot ● Z axis for general industrial equipment
K1 [Normal preload]	<input type="checkbox"/> Where the load direction is constant, impact and vibration are light. <input type="checkbox"/> Precision is not required	<ul style="list-style-type: none"> ● Welding machine ● Binding machine ● Automatic wrapping machine ● Material handling equipment

Linear Rail System

Technical Data

㉓ Linear Rail System

㉔ Ball Screw

㉕ Support Unit

㉖ Linear Ball Bush

㉗ Cross Roller Guide

㉘ Robot Carrer Guide

Memo

4-3. Rigidity

When the load is applied to Linear Rail Systems, the balls, blocks and rails experience the elastic deformation within permissible range. The ratio of displacement is known as the rigidity. The rigidity increases as the preload increases.

In case of four way equal load type, the preload is available until the load increases to some 2.8 times the preload applied.

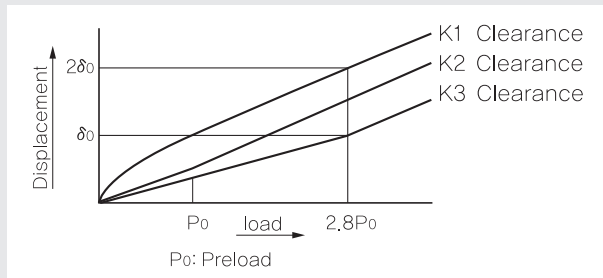

$$K = \frac{P}{\delta}$$

K ($N/\mu m$) : Rigidity

δ (μm) : Displacement

P (N) : Calculated load

5. Accuracy

Accuracy of linear rail system is generally defined by the running parallelism or the vertical and horizontal variations between the block and the rail mounting surfaces.

5-1. Running parallelism

It is tolerance of parallelism between reference of block and rail when the rail is mounted and block is moving in the whole length of rail.

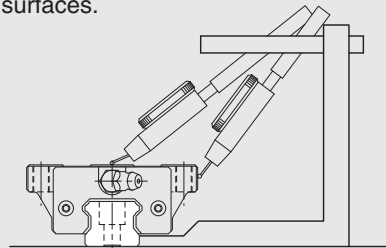

5-2. Difference in Height

Difference in height between blocks on the same rail.

5-3. Difference in width

Difference in width between rail and blocks on the same rail

5-4. Accuracy level

Accuracy levels are divided into three type – **N**, **H** and **P**.

※ See the dimension pages for each accuracy.

Linear Rail System

Technical Data

6. Design of system

Mounting method, tolerance of the mounting surfaces, and order in which the rails are mounted all affect the accuracy of machine,. Therefore we recommend considering below conditions.

6-1. Identifying reference surface

The unmarked edge of the block and the lined edge of the rail define the reference surfaces. Please note the methods below for locating these surfaces in your design.

[Master linear rail system]

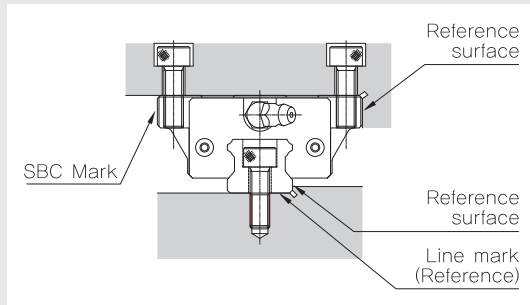

[Subsidiary linear rail system]

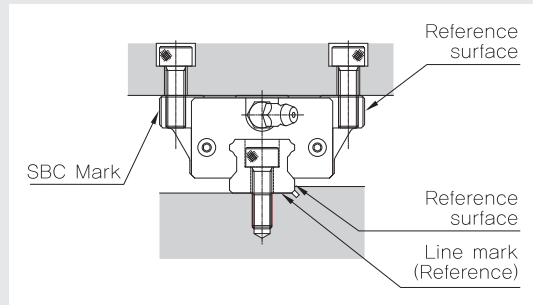

[Example of identifying reference line for pair usage]

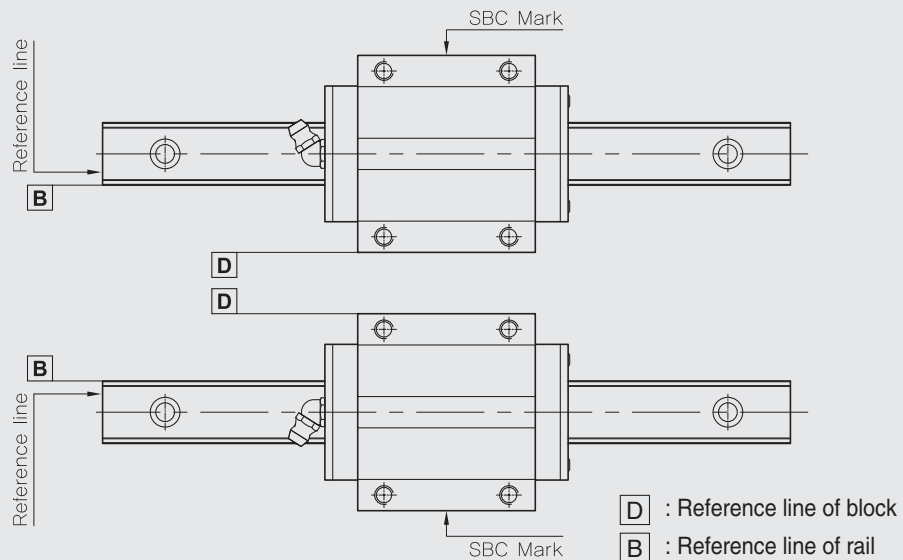

Linear Rail System

Technical Data

㉓ Linear Rail System

㉔ Ball Screw

㉕ Support Unit

㉖ Linear Ball Bush

㉗ Cross Roller Guide

㉘ Robot Carrer Guide

Memo

[Rail joint marking]

For extremely long travel applications it may be necessary to join the rails via a butt joint. These joint are matched for continuous smooth motion at the factory and numbered. When installing the segments insure that the numbers at the joints match. In the case of a double rail system the first of the two numbers identifies the rail.

Two rail joining method

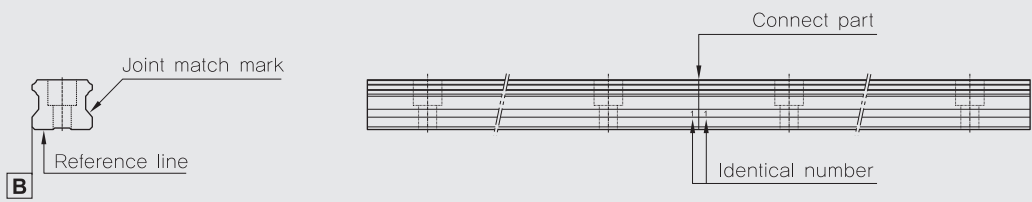

2 axis application and multiple rail joining method

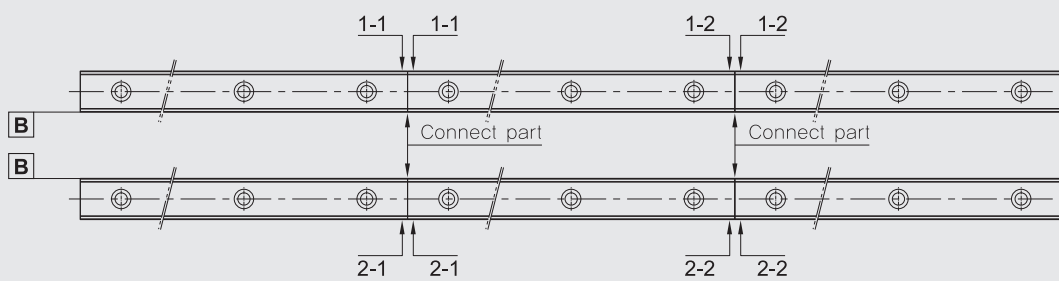

Linear Rail System

Technical Data

6-2. Shoulder height and fillet radius R

When the bearing and rail are installed on the table and base, the fillet radius, chamfer size and shoulder height must be considered.

※ See the each pages for shoulder height and fillet radius R.

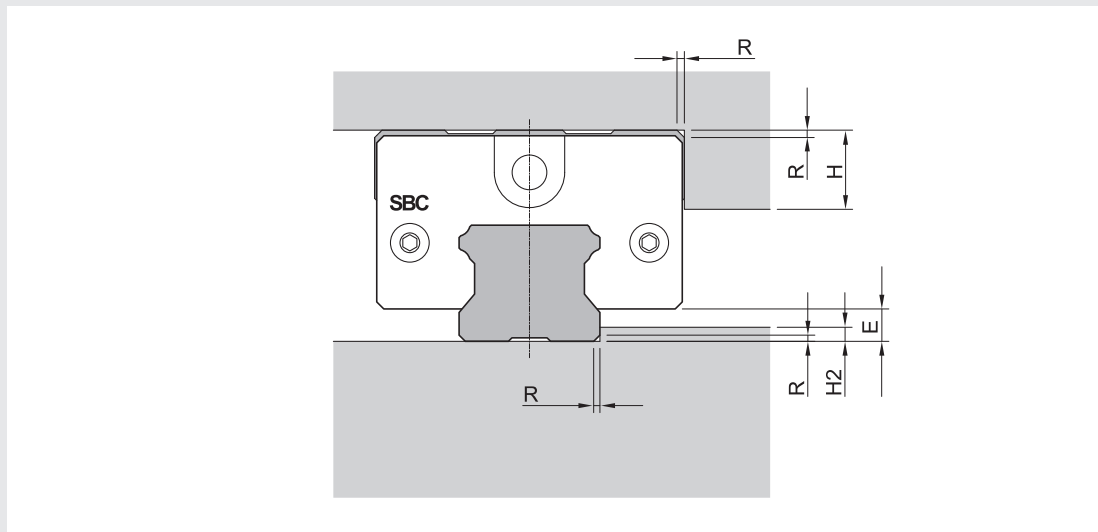

Linear Rail System

Technical Data

6-3. Permissible tolerance of mounting surface

Mounting errors can cause rolling resistance to motion. Due to the self adjusting feature of the SBC linear rail system, rolling resistance or bearing will not be affected as long as the permissible tolerance is observed as per the table shown in the catalogue.

※ See the each page for permissible tolerance of mounting surface.

[Permissible tolerance (P) of parallelism]

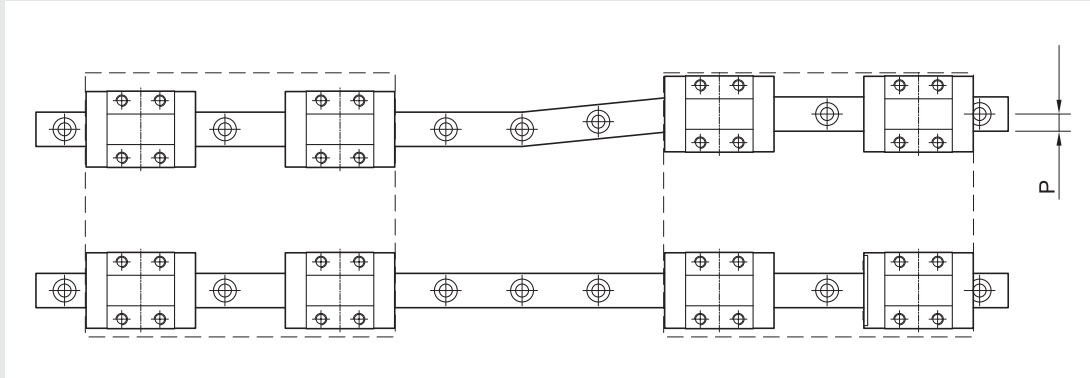

[Permissible tolerance (S) of rail mounting surface height variation]

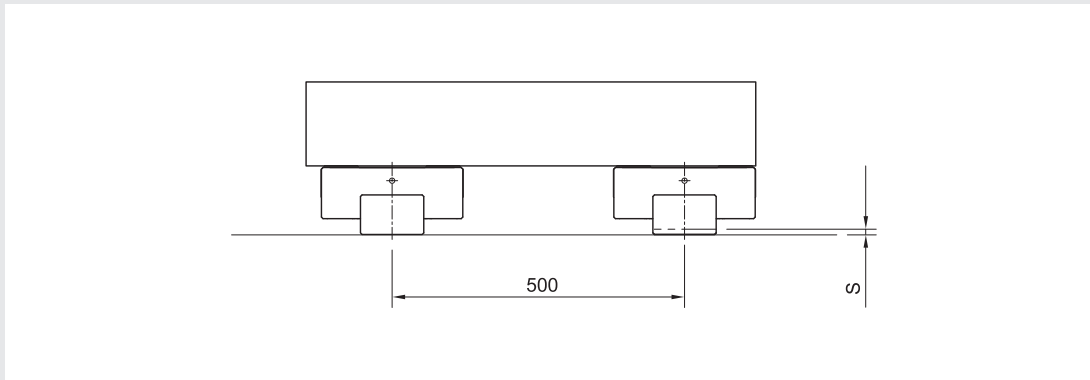

㉑ Linear Rail System

㉒ Ball Screw

㉓ Support Unit

㉔ Linear Ball Bush

㉕ Cross Roller Guide

㉖ Robot Carrer Guide

Memo

Linear Rail System

Technical Data

6-4. Mounting linear rail system

[Securing Method for Blocks and Rails]

Normally, both the bearing block and rail are mounted to the structure with bolts. When a horizontal load is applied, shock, or vibration, it is recommended that the rail be clamped horizontally against the reference surface.

(1) Cap screw mounting

Small bolts are used when space is limited. The number of bolts can be adjusted as necessary.

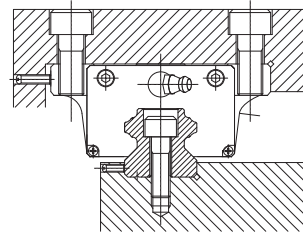

(2) Horizontal clamp mounting

This method provides an easy solution to shock and vibration applications.

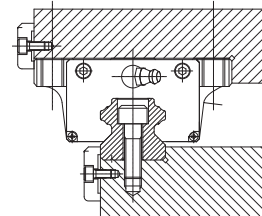

(3) Tapered Gib

This method offers the most secure means for locating the rail and block against the reference surface.

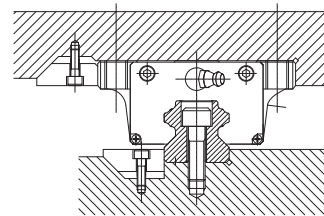

(4) Dowel Pin

Where the forces are lower and the costs more critical, dowel pins can be used to fix the rail.

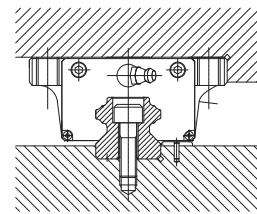

Linear Rail System

Technical Data

㉓ Linear Rail System

㉔ Ball Screw

㉕ Support Unit

㉖ Linear Ball Bush

㉗ Cross Roller Guide

㉘ Robot Carrer Guide

Memo

[Rail Mounting procedure]

- ① Clean and dry the mounting surface.
 - ② Coat each surface with low viscosity spindle oil, then place the rail on the surface and then lightly tighten the mounting bolts temporarily.
 - ③ Place the carriage plate on the blocks carefully and tighten the mounting bolts temporarily.
 - ④ Position the carriage plate by tightening the master block against the reference surface using the selected securing method and tighten the mounting bolts with a torque wrench.
- ※ Follow the above order to mount subsidiary blocks.

① Checking the mounting

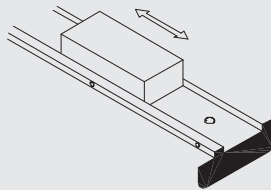

② Setting the rail against the datum plane

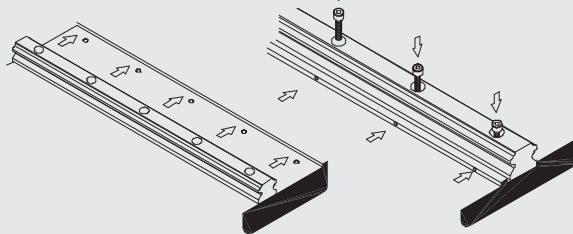

③ Tightening set screws

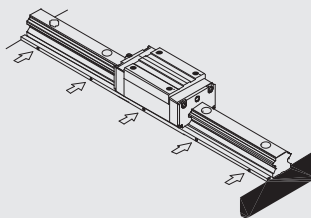

④ Final tightening of mounting bolts

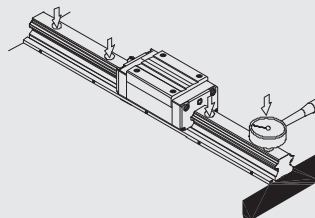

[Block Mounting procedure]

- ① Clamp the reference rail in place and tighten the mounting bolts with a torque wrench, making several passes to reach the desired torque
- ② Carefully position the table with bearings onto the rails and tighten the non-reference blocks with a torque wrench.
- ③ Starting at one end, move the table along the rail and tighten the non-reference rail slowly during several passes with a final pass using the torque wrench. Do not over tighten

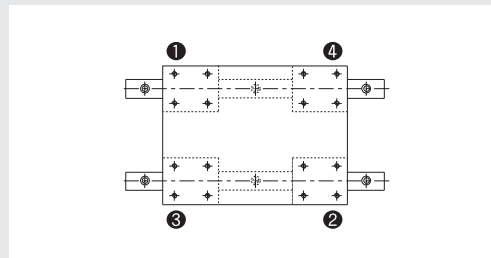

Linear Rail System

Technical Data

[Bolt mounting torque]

Below bolt mounting torque is recommended for mounting the rail.

Unit : N.cm

Bolt	Mounting torque		
	Steel	Cast iron	Aluminum
M2	58.8	39.2	29.4
M2.3	78.4	53.9	39.2
M2.6	118	78.4	58.8
M3	196	127	98
M4	412	274	206
M5	882	588	441
M6	1370	921	686
M8	3040	2010	1470
M10	6760	4510	3330
M12	11800	7840	5880
M14	15700	10500	7840
M16	19600	13100	9800
M20	38200	25500	19100
M22	51900	34800	26000
M24	65700	44100	32800
M30	130000	87200	65200

Linear Rail System

Technical Data

7. Lubrication

Lubrication for linear rail system is a key part of its performance.

- Reduce friction and wearing for each moving part.
- Eliminate the heat on linear rail system.
- Prevent corrosion on inside and outside of linear rail system.
- Dust-prevention.

7-1. Lubrication requirements for linear rail system

- Form a strong oil film
- Have high thermal stability
- Low-friction
- High water resistance
- Oil must have high-viscosity and grease must have consistency again repeated agitation of grease
- Non-corrosive

7-2. Comparison of lubrication

A comparison of the application features for oil and grease used in linear rail system is shown in the table below.

Item	Grease	Oil
Rotation	Low, intermediate	High
Seal	Simple	Cautious
Lubrication change	Complicated	Simple
Life	Short	Long
Thermal radiation	Bad	Good
Friction torque	Large	Less
Performance	Good	Excellent

㉓ Linear Rail System

㉔ Ball Screw

㉕ Support Unit

㉖ Linear Ball Bush

㉗ Cross Roller Guide

㉘ Robot Carrer Guide

Memo

Linear Rail System

Technical Data

(1) How to grease

- **With grease gun** : The grease is fed through the grease fitting on linear rail system.
- **With pump** : The grease is fed periodically by automation pump.

(2) How to feed oil

- Oil-brushed on, sprayed or pumped.

7-3. Lubricants interval

Lubricants intervals vary according to the environment and working condition of machine. Therefore, below lubricant intervals are recommended. Do not mix oil and grease systems.

Item	Checking time	Lubricant interval	Working condition and outcome
Grease	3 ~ 6 months	6 months ~ 1 year	Normal working condition
		3000km	3000km/6 months
Oil	1 week	According to checking	Volume and contamination of oil
	Everyday	Any time	Volume of oil

Linear Rail System

Technical Data

7-4. Class of oil

Lubricant	Class
Oil	Coolant oil, turbine oil ISOVG32 ~ 68

7-5. Classification and selection of lubrication

Lubricant for linear rail system must be selected after considering vibration, clean room, vacuum and working condition.

SBC supplies two kinds of grease as standards.

Item	Application	Brand
Normal working condition	Multipurpose industrial application	Shell Alvania EP(LF)0 [Korea Shell]
Special working condition	Clean room	SNG 5050 [NTG Korea]
	Vibration	
	Wide temperature	

* Contact SBC for special lubes or MSDS sheets

㉓ Linear Rail System

㉔ Ball Screw

㉕ Support Unit

㉖ Linear Ball Bush

㉗ Cross Roller Guide

㉘ Robot Carrer Guide

Memo

Linear Rail System

Technical Data

[Normal working condition: Multipurpose industrial application]

[1] General

- **Name :**
Shell Alvania EP(LF)0
- **Company :** Korea Shell
- **Appearance :** Bright brown color, semi-solid in normal temperature

[2] Special feature

- High load resistance
- Anti-corrosive
- High liquidity
- High mechanical stability

[3] Representative feature

- **Consistency enhancer :**
Lithium
- **Base oil :** Mineral oil
- **Working temperature :**
-30°C ~ 100°C

Test item	Representative value	Test method
Consistency [25°C, 60 times]	0	NLGI *
Dropping point	180°C	ASTM D 566
Copper plate corrosion [Method B, 100°C, 24h]	1 B	ASTM D 4048
Evaporation [99°C, 22h]	0.40%	ASTM D 972
Stability of oxidation [99°C, 100h]	0.40 kgf/cm ²	ASTM D 942
Mixing stability [100,000cycles]	393	ASTM D 217

* NLGI :National Lubricating Grease Institute

Consistency test method	KS	NLGI
	355 ~ 385	0

Linear Rail System

Technical Data

[Special working condition : Wide-temperature and low dust accumulating]

[1] General

- **Name** : SNG5050
- **Company** : NTG Korea
- **Appearance** : Butter in normal temperature

[2] Special feature

- Excellent stability of oxidation
- Long life grease
- Low dust accumulating and excellent chemical-resistance
- Wide temperature range

[3] Representative feature

- **Consistency** : Urea
- **Base oil** : Synthetic oil
- **Working temperature** : -40°C ~ 200°C

Test item	Representative value	Test method
Consistency [25°C, 60 times]	3	NLGI *
Dropping point	280°C	JIS K 2220 5.4
Evaporation (22h) mass %	99°C	JIS K 2220 5.6
	150°C	JIS K 2220 5.6
Oil separation rate (24h) mass %	150°C	JIS K 2220 5.7
Film evaporation (24h) mass %	150°C	-
	180°C	-
Stability of oxidation [99°C, 100h] mass %	0.015%	JIS K 2220 5.8
Mixing stability [100,000cycles]	Pass	ASTM D 1743
Wear resistance (1200rpm, 392N, room temperature 1h)	0.57	ASTM D 2266

* NLGI : National Lubricating Grease Institute

Consistency test method	KS	NLGI
	220 ~ 250	3

㉓ Linear Rail System

㉔ Ball Screw

㉕ Support Unit

㉖ Linear Ball Bush

㉗ Cross Roller Guide

㉘ Robot Carrer Guide

Memo

Linear Rail System

Technical Data

7-6. Grease fitting

Select the appropriate grease fitting from below options in accordance with design.

[Standard grease fitting]

Front grease fitting (except SBM, SBMW) for linear rail system is standard grease fitting.

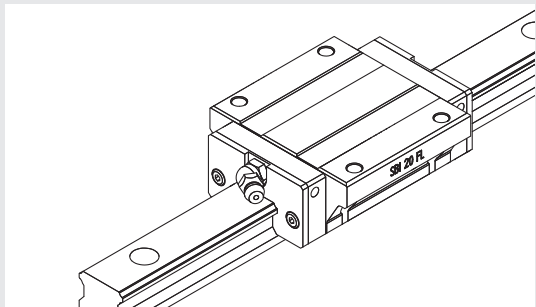

(SBG, SBI front grease fitting)

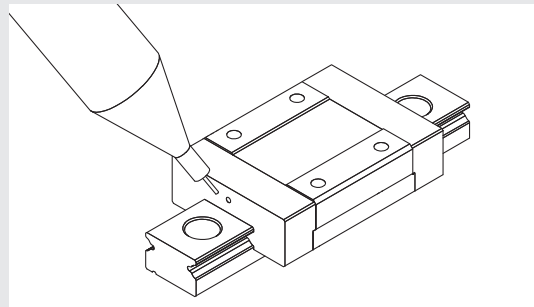

(SBM, SBMW front grease fitting)

[Side grease fitting]

When greasing is difficult because of limited space in front of the grease nipple, the side grease fitting can be supplied. (*Side grease fitting is not available for SBM, SBMW.)

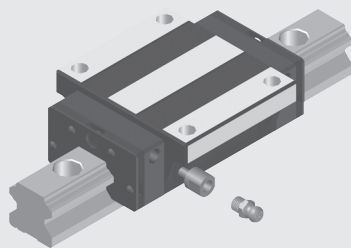

(SBG, SBI 15~25 FL side grease fitting)

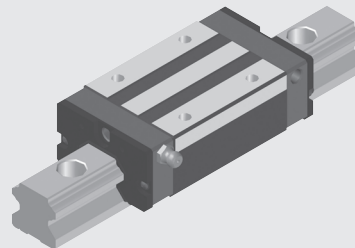

(SBG, SBI SL side grease fitting)

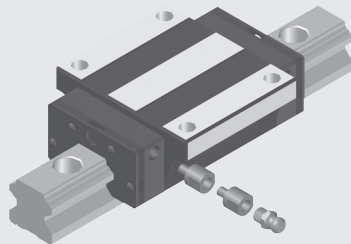

(SBG 30~35 FL side grease fitting)
(SBI 30~45 FL side grease fitting)

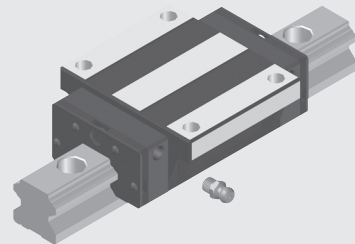

(SBG 45~65 FL side grease fitting)
(SBI 55~65 FL side grease fitting)

Linear Rail System

Technical Data

8. Safety design

Dust prevention, rust prevention and re-lubrication according to working conditions of the linear rail system are necessary for required life time.

8-1. Anti-rust

3 types of surface treatment are available for anti-rust and appearance.

[Chrome plating]

It achieves high rust resistance and wear resistance with the coating film of over 750HV.

[Raydent-treatment]

For corrosion resistance, raydent surface treatment is available.
This treatment is suitable for corrosion resistance.

[Fluorocarbon raydent treatment]

Fluorocarbon coating on raydent-treatment is suitable where high corrosion resistance is required (water or salty water working condition).

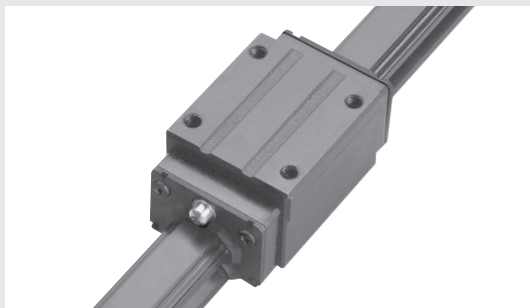

(Raydent)

[Caution for surface treatment]

- ① Be aware that the rail hole may not surface treated.
- ② Set the higher safety factor in case surface treated linear rail system is selected.
- ③ Except above surface treatments, the other plating may cause performance problems.
- ④ Contact SBC for other information on surface treatments.

㉓ Linear Rail System

㉔ Ball Screw

㉕ Support Unit

㉖ Linear Ball Bush

㉗ Cross Roller Guide

㉘ Robot Carrier Guide

Memo

Linear Rail System

Technical Data

8-2. Dust protection

The dimensions for each seal is shown on dimension page.

[Seal options]

Select the appropriate seal options according to working conditions.

Item	Symbol	Application
End seal	No symbol (Standard)	Normal condition
End seal + end seal	DD	Dust condition
End seal + scraper	ZZ	Welding spatter
End seal + end seal + scraper	KK	Dust and chips

* Bottom seal is not available for SBI, SBG, SBS15

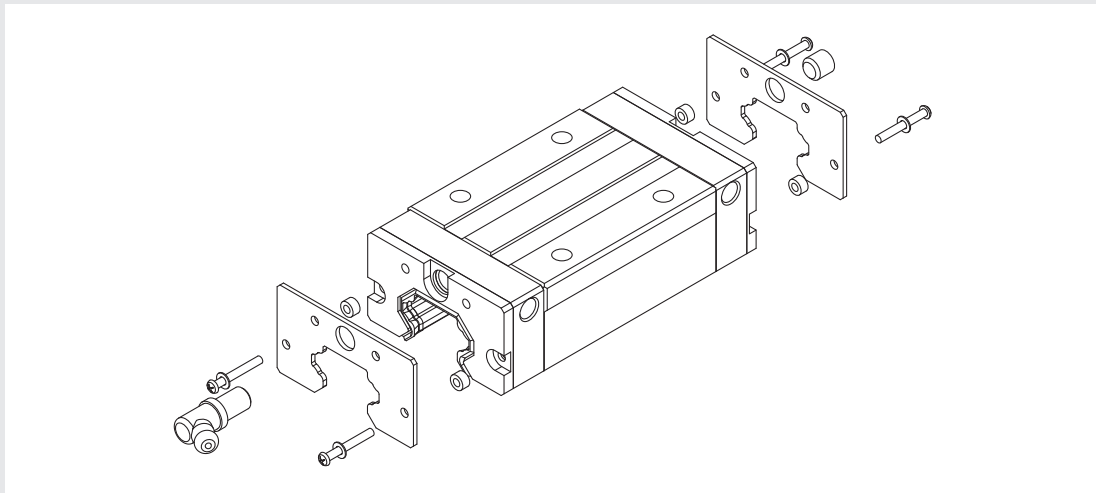

Linear Rail System

Technical Data

③ Linear Rail System

④ Ball Screw

⑤ Support Unit

⑥ Linear Ball Bush

⑦ Cross Roller Guide

⑧ Robot Carrier Guide

Memo

[RC cap: rail hole cap]

Contaminants invade into the bolt holes of the rail and pollute the inside of the bearing. You can use hole caps made from hardened rubber to fill the holes. RC caps are provided with the rails.

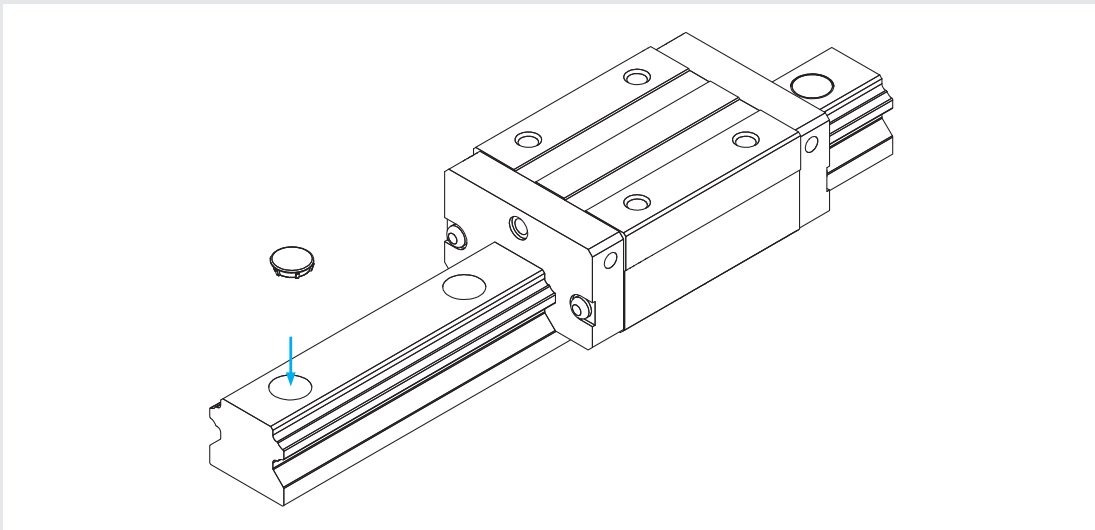

◁ RC cap mounting method ▷

- ① Bolt the rail on the plate.
- ② Put the RC cap on the rail mounting hole and place the bigger steel plate on the cap then tap it with hammer.
- ③ Check the RC cap to make sure it is properly seated.

Linear Rail System

Technical Data

[ST dustproof tape]

Stainless steel ST dustproof tape greatly improves rail face sealing and works in conjunction with guide block seals. Conventional plastic plugs do not offer the same improved sealing performance.

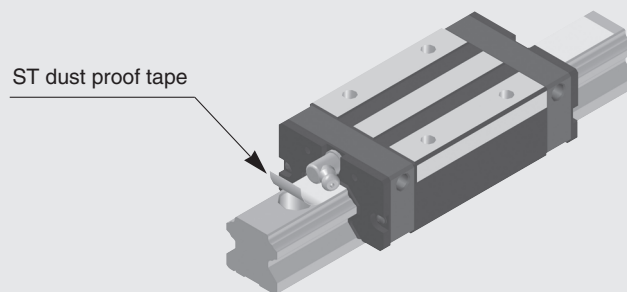

< Installation of ST tape >

- ① After assembling a rail to the bed, clean the surface of the rail and remove any oil.
 - ② Attach the ST tape slowly over the rail length to within 2 or 3 mm from each end of the rail.
 - ③ After attachment to the rail, apply pressure with dry cloth 3 or 4 times along the length of the rail to release encapsulated epoxy. Tape should be applied 4 to 6 hours prior to use to allow initial bonding.
- ※ It is strongly recommended to wear safety gloves, the edge of this tape is sharp and can cut as you attach it to the rail.

[Bellows]

For the best protection of the linear rail system, bellows should be used.

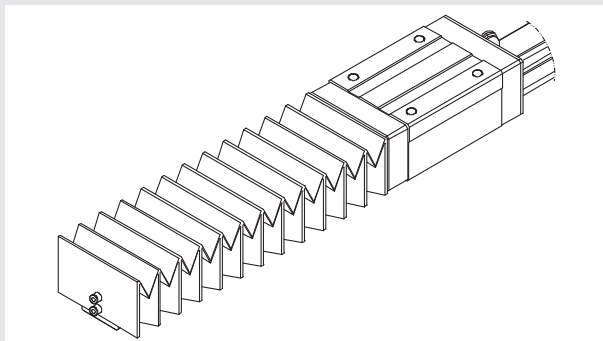

- Reference : SBI type : SH-A
SBG type : SH

Linear Rail System

Technical Data

8-3. High temperature design

[HT end-plate]

If working temperature is more than 80°C, SBC supply the high temperature end-plate which is made of aluminum.

- Recommended working temperature : -20 ~ 180°C

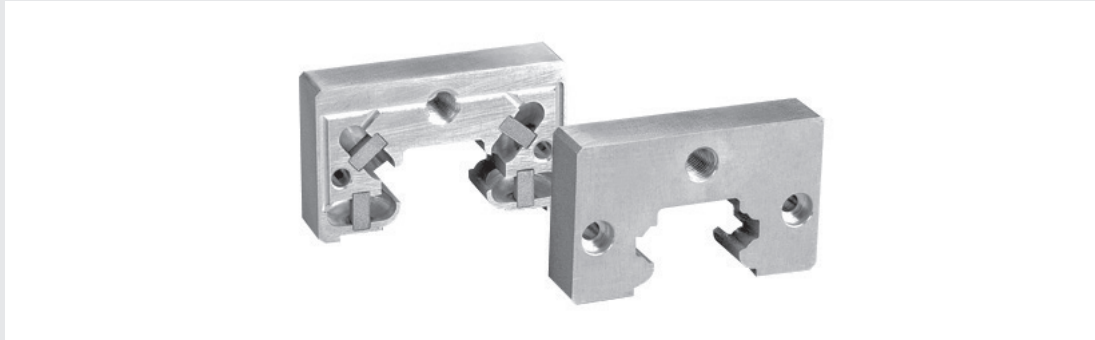

※ For high temperature applications we can replace all plastic components with steel or aluminum.

③ Linear Rail System

④ Ball Screw

⑤ Support Unit

⑥ Linear Ball Bush

⑦ Cross Roller Guide

⑧ Robot Carriage Guide

Memo

Linear Rail System

Technical Data

8-4. High dust-proof and self-lubricant container

For protecting the linear rail system from fine foreign matter and where the grease feeding is not easy, SBC created the high dust-proof, (DF) seal and self-lubricant container (MF).

- Function and classification in accordance with seal type

DF : Dust protection for fine foreign matter

MF : Self lubricating for long maintenance intervals

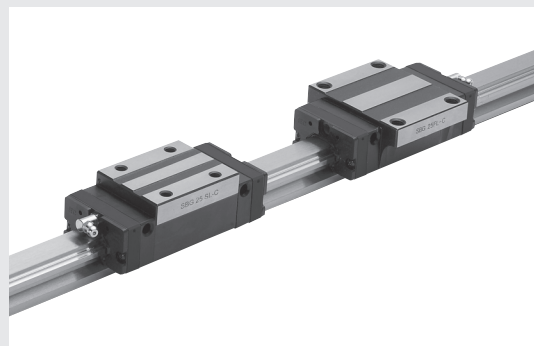
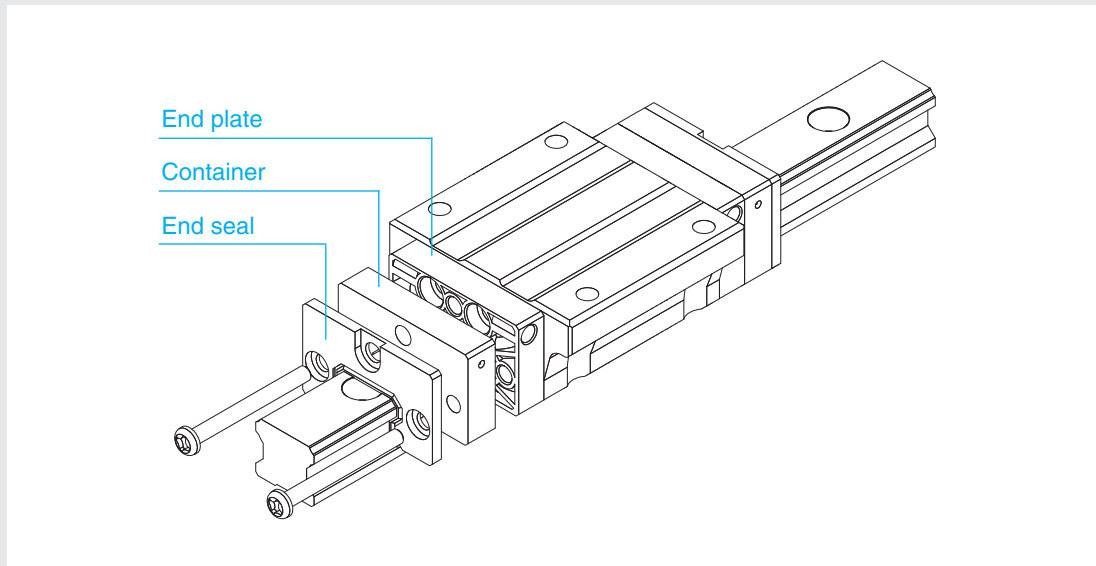

Linear Rail System

Technical Data

㉓ Linear Rail System

㉔ Ball Screw

㉕ Support Unit

㉖ Linear Ball Bush

㉗ Cross Roller Guide

㉘ Robot Carrer Guide

Memo

[High dust-proof seal : DF seal]

High-density felt built in DF container wipes the raceway tracking profile with a thin film of oil. An additional seal or scraper may be added for highly contaminated applications.

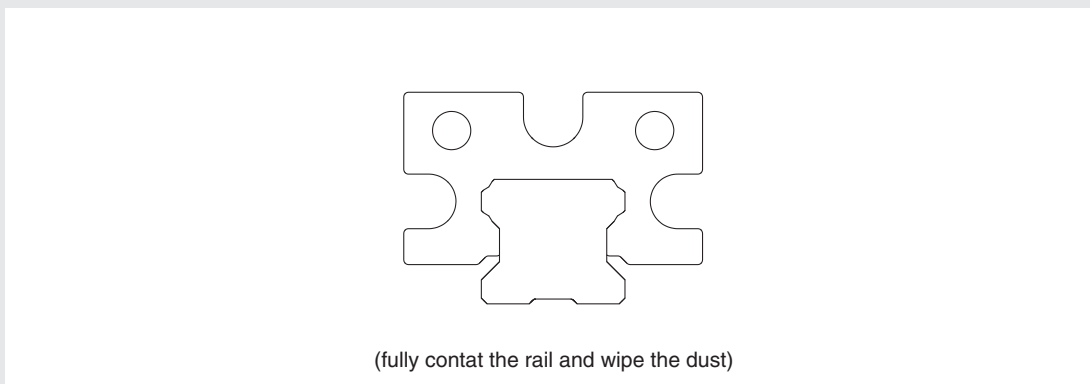
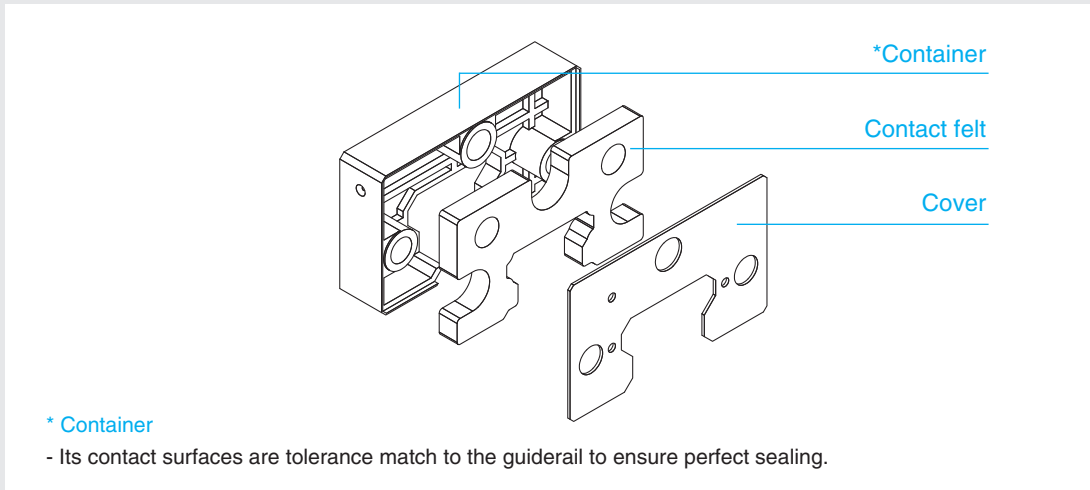

※ Caution

If you would like to use DF seal in watery or clean-room working condition, please contact SBC.

Linear Rail System

Technical Data

[Self lubricant : MF container]

MF (Self lubricating) contains grease impregnated felt which feeds the grease on the raceway continuously. Each compact seal kit will guarantee total surface lubrication and long maintenance free bearing life.

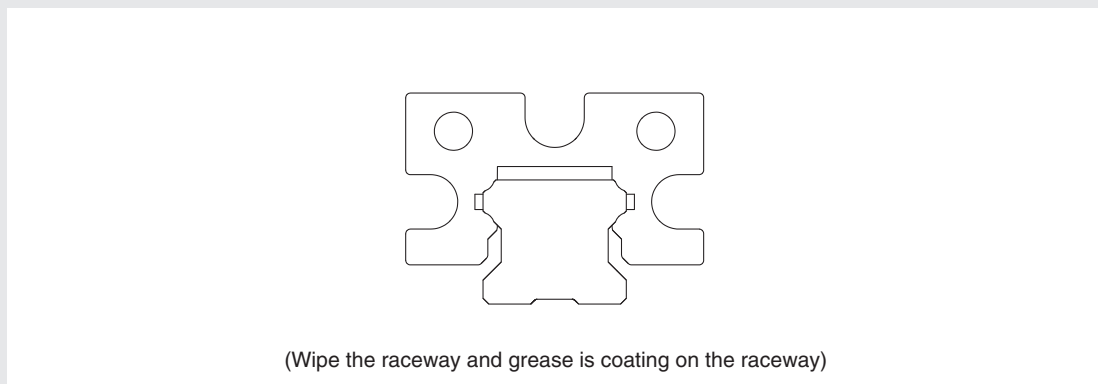
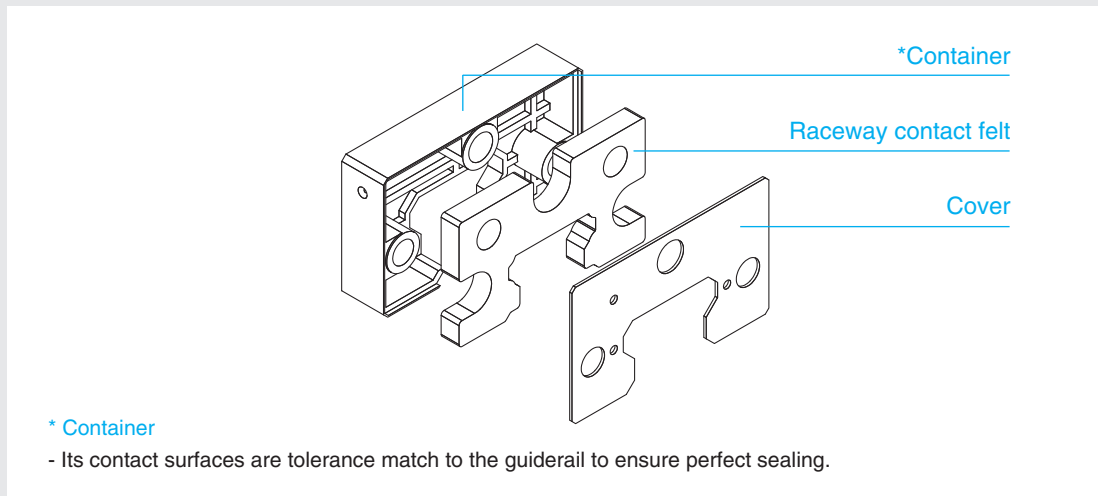

Linear Rail System

Technical Data

8-5. MF container Lifetime test

[Performance test]

- SBG20SL-1-K1-1500-N

Condition	Heavy	Medium	Light
Load	4.9kN	2.5kN	1.0kN
Velocity	20m/min		
Theoretical Lifetime	600km	1500km	-

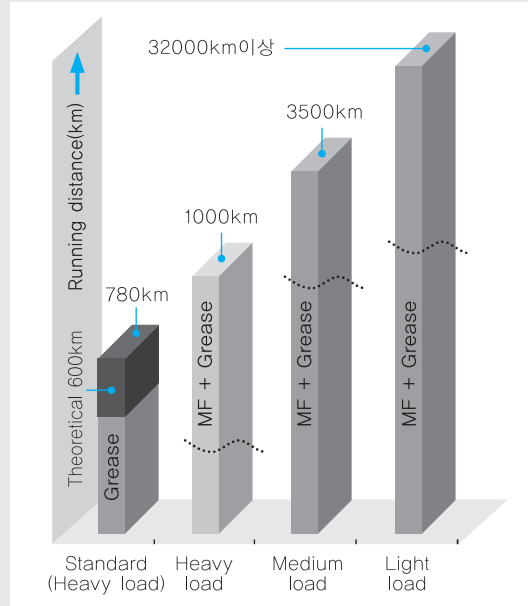

[Grease feeding]

The MF container may be re-charged by adding grease to hole inside of block with a syringe.

※ Caution

If MF container is required to use in special working condition like clean room, please contact SBC.

㉓ Linear Rail System

㉔ Ball Screw

㉕ Support Unit

㉖ Linear Ball Bush

㉗ Cross Roller Guide

㉘ Robot Carrer Guide

Memo

Linear Rail System

The Types of Linear Rail System

SBI high-load type

With all advantages of our SBG type, SBI improves load capacity, and increases speed capabilities for the rail system.

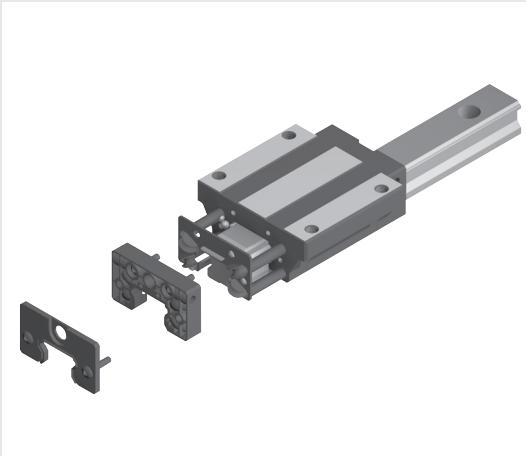

SBI type

-Type: SBI15~65

SBM miniature

Miniature linear rail system with compact size also achieve high-load.

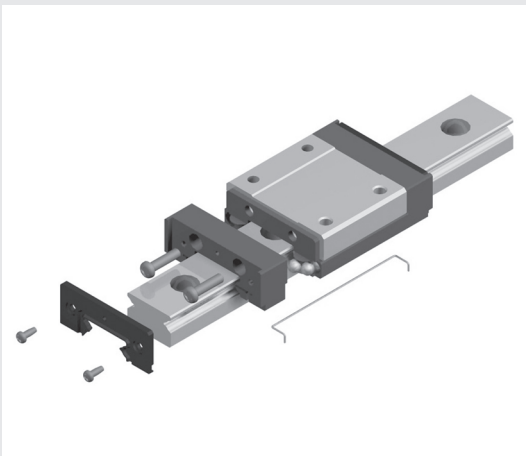

SBM (Standard miniature)

-Type: SBM09~15

SBML (High-load miniature)

-Type : SBML09~15

SBMW (Wide type miniature)

-Type: SBMW09~15

Linear Rail System

The Types of Linear Rail System

SBG standard

Standard SBC linear rail system.

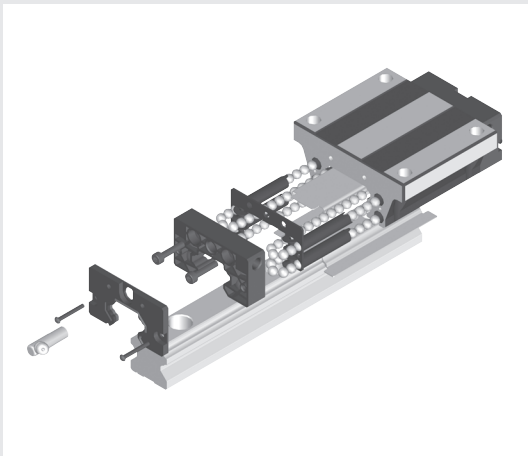

SBG type

Type: SBG 15~65

SBS type

-Assembly height is lower than SBG type

-Type : SBS 15~45

SPG spacer

Low noise type in which the plastic spacer are inserted in between balls.

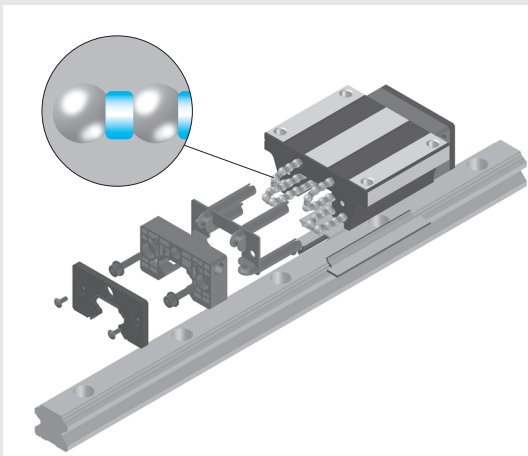

Low noise (Spacer type)

Spacer are inserted in between balls

SPG (=SBG dimensionally interchangeable)

Type : SPG 20~35

SPS (=SBS dimensionally interchangeable)

-Type: SPS 20~35

㉓ Linear Rail System

㉔ Ball Screw

㉕ Support Unit

㉖ Linear Ball Bush

㉗ Cross Roller Guide

㉘ Robot Carrer Guide

Memo

Linear Rail System

SBI High-load Linear Rail System

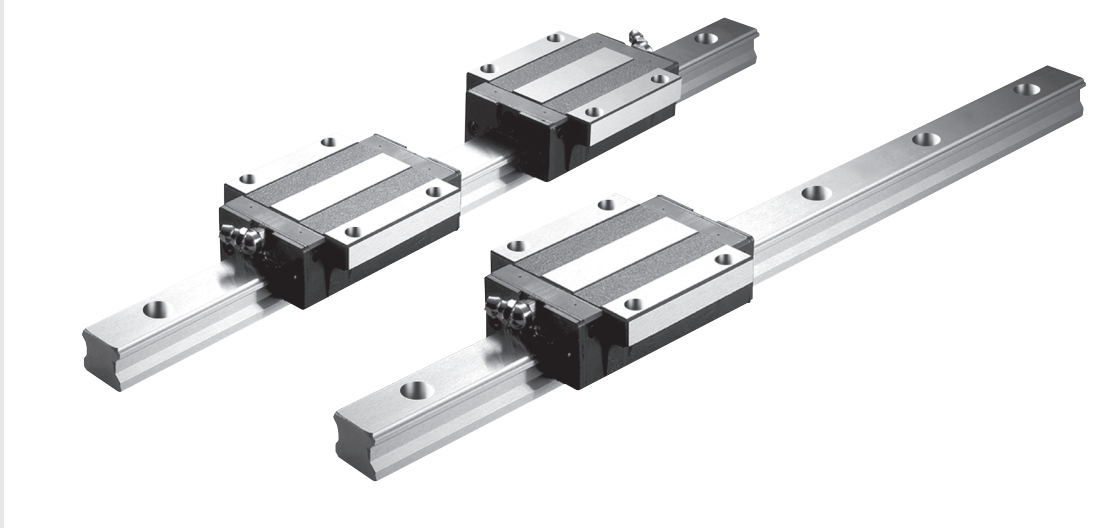

Circular arc groove

Two point contact structure of circular arc groove. It keeps the function of self-aligning and smooth rolling performance.

45° angle of contact

Four rows of circular arc groove contact balls at an angle of 45 degrees provides the same capacity in all directions.

DF structure

Low noise and High rigidity

Optimized ball recirculation structure and design provides low noise and high-rigidity.

The same dimension

The dimension of height, width and mounting holes are the same as SBG series, with only a slight variation in block length.

Linear Rail System

SBI High-load Linear Rail System

The feature of structure

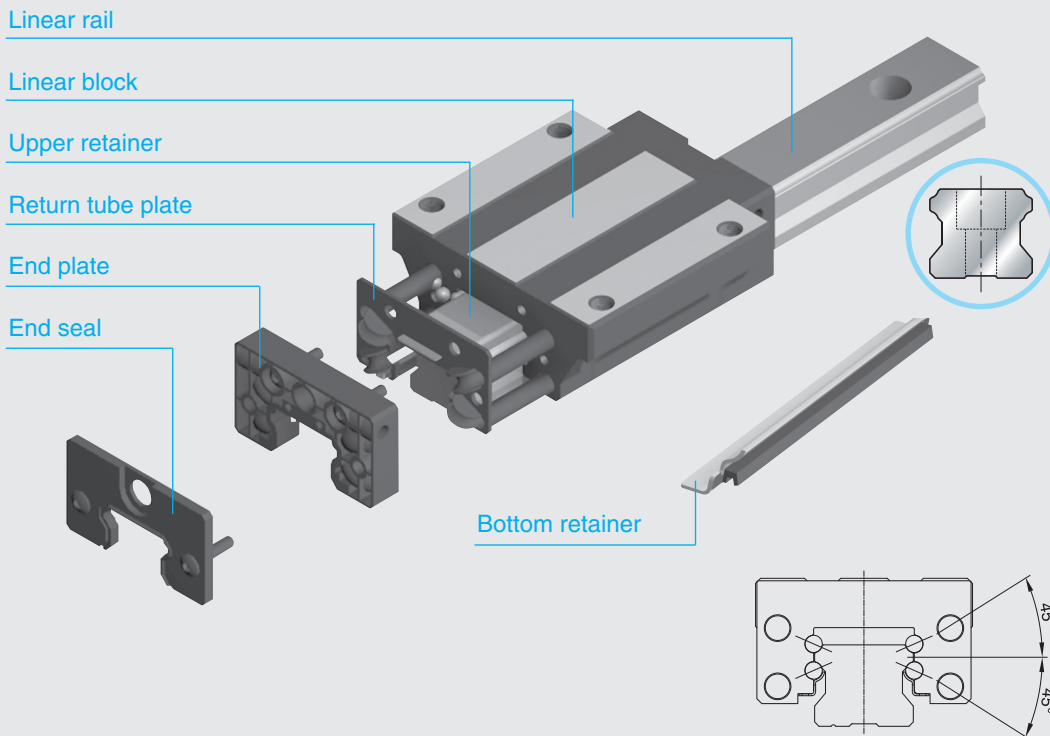

End seal New double lip structure which improves resistance to dust and particle contamination.

Retainer Ball retainer plates now snap assembled to the blocks and this unique assembly method allows an amount of internal self-alignment and load sharing while maintaining rigid ball control.

Linear block Highly rigid structure with a larger recirculation radius for the smooth movement and longer block length for higher load capacity.

End-plate Manufactured with a new high rigidity engineered plastic. Designed to withstand the highest of unplanned impact loads without breaking.

Return tube plate The end plate and reversing ramps of new ball return tubes are now molded as one complete body. This allows for smoother ball rotation through the critical transition points, significantly improving rolling performance, lower operating better lubricant retention inside the bearing.

Linear rail SBI rail is designed with a low profile and wide base. This characteristic allows greater stability in operation and during manufacture. Results in greater linear precision.

㉓ Linear Rail System

㉔ Ball Screw

㉕ Support Unit

㉖ Linear Ball Bush

㉗ Cross Roller Guide

㉘ Robot Carrer Guide

Memo

Linear Rail System

SBI High-load Linear Rail System

[Low noise]

- SBI25 / SBG25 noise level test data

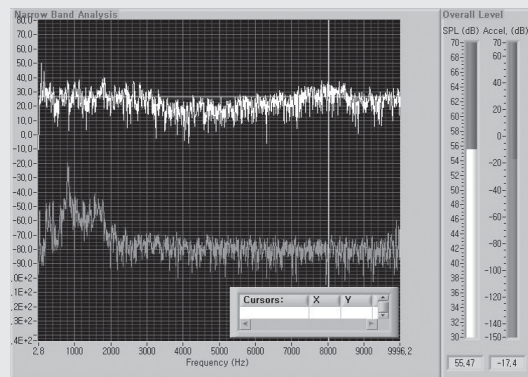
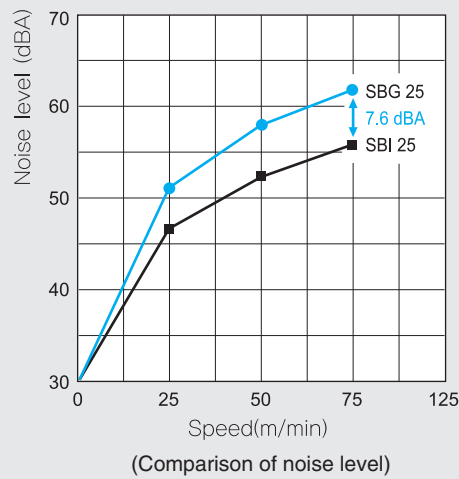

(SBI 1.3m/sec)

[High load performance]

SBI type is improved load capacity from the longer block length and changed radius of curvature

- The comparison of SBI / SBG block length

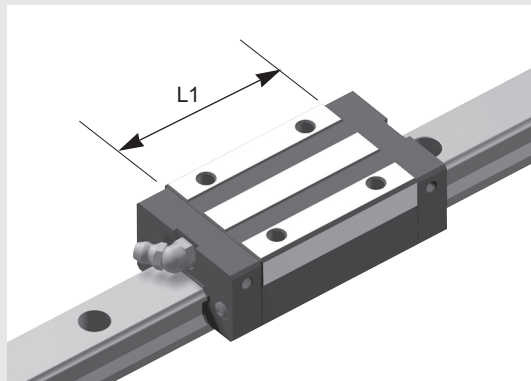

(Unit : mm)

L1 length	SBG	SBI
15SL	38.8	45.2
20SL	50.8	56.8
25SL	59.5	70

Linear Rail System

SBI High-load Linear Rail System

㉓ Linear Rail System

㉔ Ball Screw

㉕ Support Unit

㉖ Linear Ball Bush

㉗ Cross Roller Guide

㉘ Robot Carrer Guide

Memo

- The comparison of basic dynamic load rating

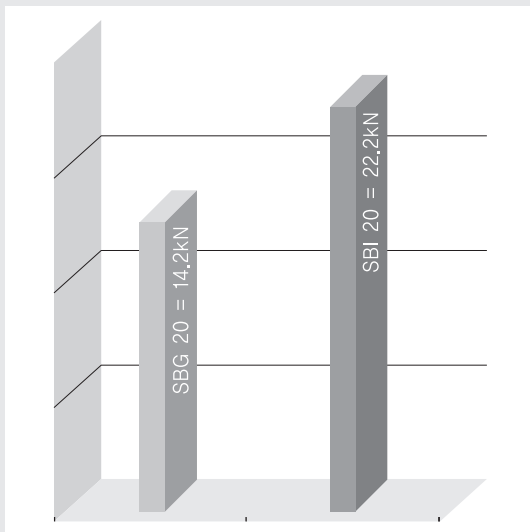

(Comparison of basic dynamic load rating)

Improved geometry and tolerances increases basic dynamic load rating

- Comparison of lifetime calculation

- L (km) : Nominal life
- C (kN) : Basic dynamic load rating
- P (kN) : Calculated load

$$L = \left(\frac{C}{P} \right)^3 \times 50\text{km}$$

In case of P = 5 kN

Basic dynamic load rating (C) of SBI20 SL : 22.2 kN

Basic dynamic load rating (C) of SBG20 SL : 14.2 kN

$$\text{SBI 20SL} : L = \left(\frac{C}{P} \right)^3 \times 50 = \left(\frac{22.2}{5} \right)^3 \times 50 = 4376 \text{ km}$$

$$\text{SBG 20SL} : L = \left(\frac{C}{P} \right)^3 \times 50 = \left(\frac{14.2}{5} \right)^3 \times 50 = 1145 \text{ km}$$

Linear Rail System

SBI High-load Linear Rail System

Accuracy

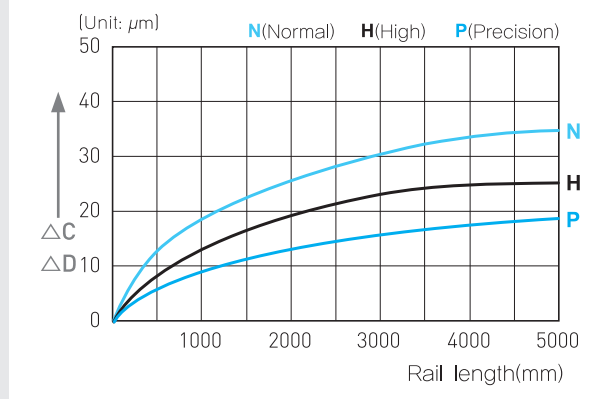
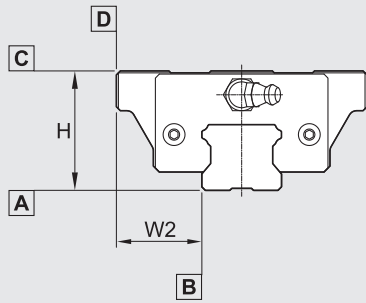

Item	N	H	P
Tolerance for the height H	±0.1	±0.04	±0.02
Tolerance for the rail-to-block lateral distance W2	±0.1	±0.04	±0.02
Tolerance for the height H difference among blocks	0.03	0.015	0.007
Tolerance for rail-to-block lateral distance W2 distance among blocks	0.03	0.015	0.007
Running parallelism of surface C with surface A	ΔC		
Running parallelism of surface D with surface B	ΔD		

● N : Normal ● H : High ● P : Precision

Preload

Reference	Volume of preload
K0 (None)	Clearance within 0.01mm
K1 (Normal)	Max. 0.02C
K2 (Light)	0.04 ~ 0.06C
K3 (Heavy)	0.08 ~ 0.10C

● C(kN) : Basic dynamic load rating

※ "K3" Preload is not available for SBI15 type

Linear Rail System

SBI High-load Linear Rail System

Shoulder height and fillet radius R

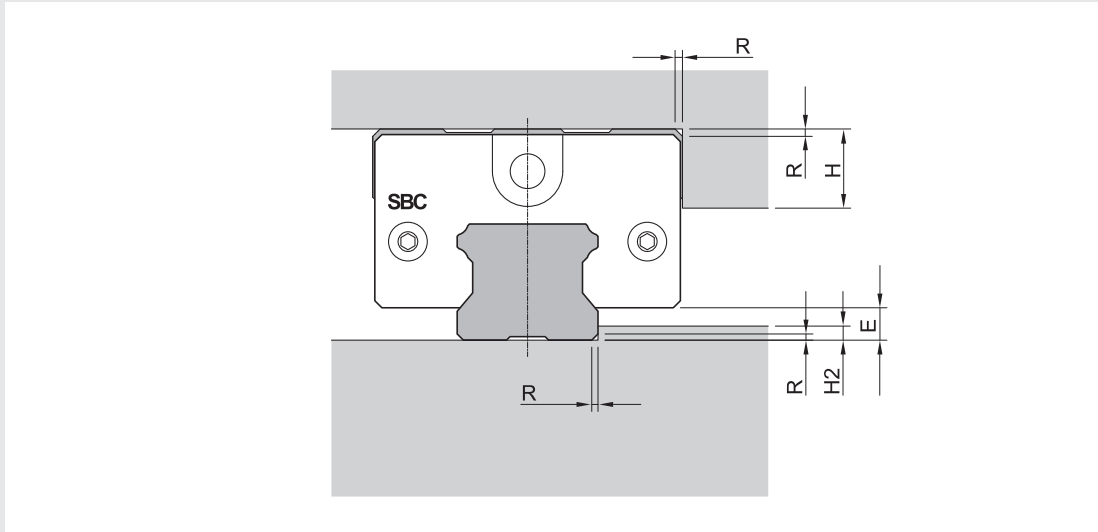

(Unit : mm)

Model number	Fillet radius R	Shoulders height H1	Shoulders height H2	E
15	0.6	7	2.5	3
20	0.6	8	3.5	4.6
25	1	10	4.5	5.5
30	1	11	5	7
35	1	13	6	7.5
45	1.6	16	8	9
55	1.6	20	10	12
65	1.6	25	15	19

㉓ Linear Rail System

㉔ Ball Screw

㉕ Support Unit

㉖ Linear Ball Bush

㉗ Cross Roller Guide

㉘ Robot Carreer Guide

Memo

Linear Rail System

SBI High-load Linear Rail System

Permissible tolerance (P) of parallelism

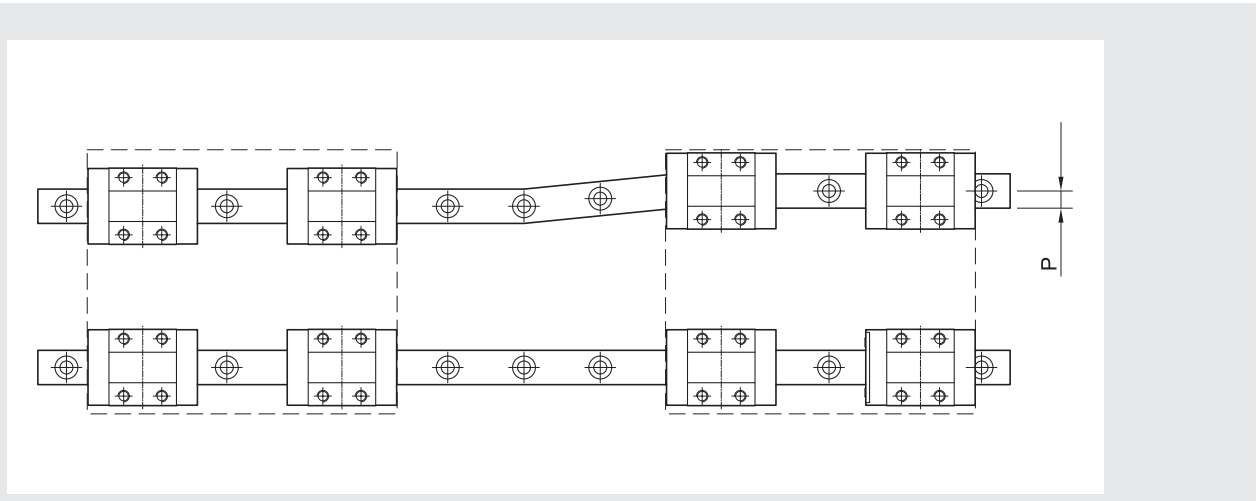

(Unit : mm)

Model size	K1	K2	K3
15	0.025	0.018	-
20	0.025	0.020	0.018
25	0.030	0.022	0.020
30	0.040	0.030	0.027
35	0.050	0.035	0.030
45	0.060	0.040	0.035
55	0.070	0.050	0.045
65	0.080	0.060	0.055

Linear Rail System

SBI High-load Linear Rail System

Permissible tolerance (S) of two level offset

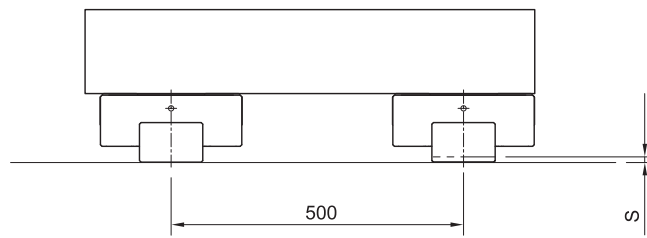

(Unit : mm)

Model size	K1	K2	K3
15	0.13	0.085	-
20	0.13	0.085	0.05
25	0.13	0.085	0.07
30	0.17	0.11	0.09
35	0.21	0.15	0.12
45	0.25	0.17	0.14
55	0.30	0.21	0.17
65	0.35	0.25	0.20

㉓ Linear Rail System

㉔ Ball Screw

㉕ Support Unit

㉖ Linear Ball Bush

㉗ Cross Roller Guide

㉘ Robot Carrer Guide

Memo

Linear Rail System

SBI High-load Linear Rail System

SH Bellows

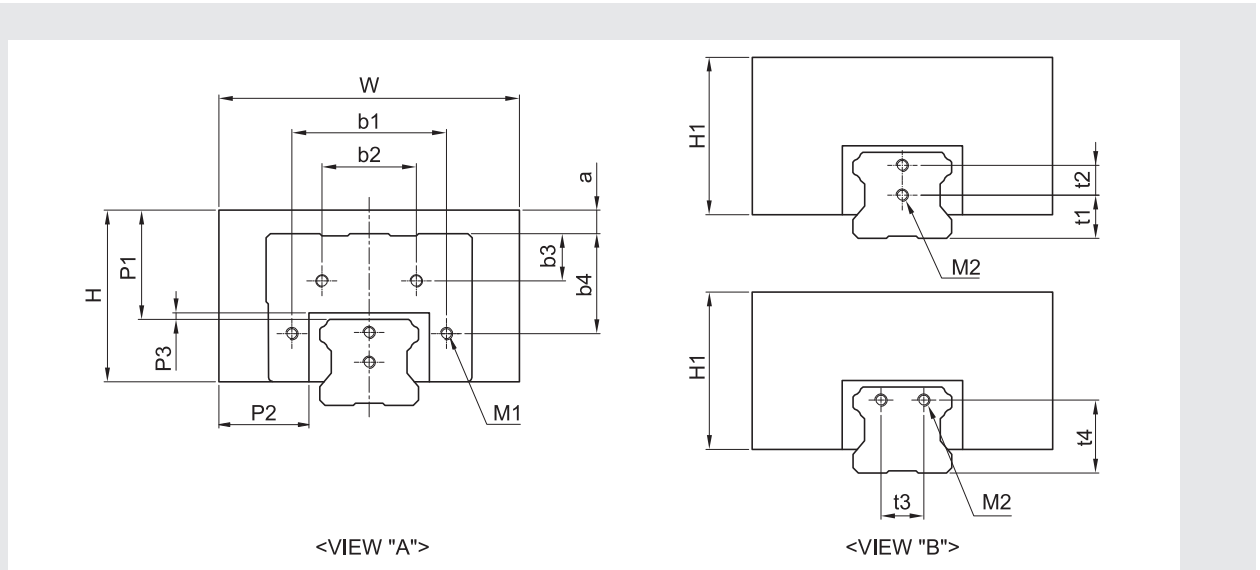

Model number	Applicable type	W	H	H1	P1	P2	P3	a (*Dimensions according to block types)						b1	b2
								FV	SV	CL	FL	SL	HL		
SH15 A	SBI15	50	25	25	15	15.5	1	4	4	-	4	0	4	26	-
SH15 DA			20	20	10			-1	-1	-	-1	-5	-1		
SH20 A	SBI20	60	29	31	17	18	1	5.5	5.5	5.5	3.5	3.5	-	34 (32)	-
SH20 DA			24	26	12			-	-	-	-1.5	-1.5	-		
SH25 A	SBI25	70	35	35	20	21	1	7	7	7	4	0	4	36	-
SH25 DA			30	30	15			-	-	-	-1	-5	-1		
SH30 A	SBI30	80	36	36	20	23	1	-	-	-	1	-2	1	49	-
SH30 DA			33	33	17			-	-	-	-2	-5	-2		
SH35 DA	SBI35	85	39	39	20	22.5	1	-	-	-	-2	-9	-2	56	-
SH45 DA	SBI45	100	48	48	25	25	1	-	-	-	-3	-13	-3	72	-
SH55 DA	SBI55	110	56	56	30	25	1	-	-	-	-2	-12	-2	74	53.4
SH65 DA	SBI65	130	69	69	35	30	1	-	-	-	-2	-2	-	90	64

- * The column of b1 dimension is only applying for SBI20CLS type.
- * The dimension in column "a, b3 and b4" are common for FL=FLL, SL=SLL and HL=HLL, HLS.
- * If SH bellows are applying, rail end mounting holes are necessary.
- * When you select SH bellows, please select the side grease fitting for lubrication.
- * Please contact SBC for more information.

Linear Rail System

SBI High-load Linear Rail System

㉓ Linear Rail System

㉔ Ball Screw

㉕ Support Unit

㉖ Linear Ball Bush

㉗ Cross Roller Guide

㉘ Robot Carrer Guide

Memo

[Calculation of bellows length]

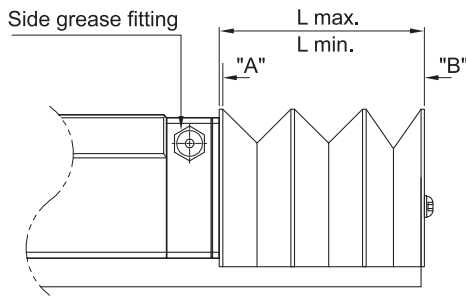

$$A = \frac{L_{max}}{L_{min}}$$

- L_{max} : Extended length (mm)
- L_{min} : Collapsed length (mm)

	L _{min}	L _{max}
*SBI 15, 20	Stroke ÷ 5	L _{min} + Stroke
*SBI 25~45	Stroke ÷ 6	
*SBI 55~65	Stroke ÷ 7	

(Unit : mm)

b3			b4						t1	t2	t3	t4	M x Bolt length		A
FL	SL	HL	FV	SV	CL	FL	SL	HL					M1(Block)	M2(Rail)	Extended ratio
-	-	-	13.3	13.3	-	13.3	17.3	13.3	10	-	-	-	M3X16	M4X8	6
-	-	-	14	14	14	16	16	-	6	8	-	-	M3X18	M3X6	6
-	-	-	16.3	16.3	16.3	19.3	23.3	19.3	10	7	-	-	M3X18	M3X6	7
-	-	-	-	-	-	22.8	25.8	22.8	11	8	-	-	M4X22	M4X8	7
-	-	-	-	-	-	26.5	33.5	26.5	-	-	14	21	M4X22	M4X8	7
-	-	-	-	-	-	33.5	43.5	33.5	-	-	20	25	M4X25	M5X10	7
7	17	7	-	-	-	38.5	48.5	38.5	-	-	26	29	M5X30	M5X10	8
7	7	-	-	-	-	45	45	-	-	-	34	42	M5X35	M5X10	8

Ordering example : **SH25A - 70 / 420**

① ② ③

- ① Model number
- ② Collapsed length (mm)
- ③ Extended length (mm)

※ 'H' dimesion of SH-DA type is lower than SH-A type

Linear Rail System

SBI High-load Linear Rail System

RC Cap

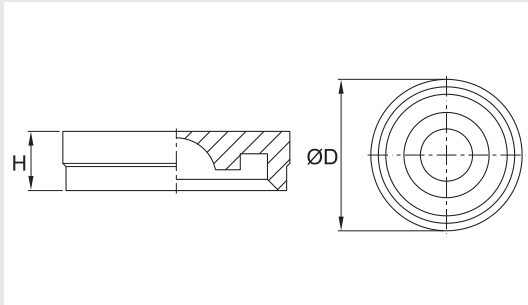

(Unit : mm)

Model	D±0.1	H±0.1
RC 15	7.6	1.3
RC 20	9.6	3.5
RC 25	11.1	2.8
*RC 30	14.2	3.7
RC 45	20.2	4.7
RC 55	23.2	6
RC 65	26.2	6

- RC 30 is used for SBI 30, 35 rail.
- SBI, SBG type use same RC cap.

ST Tape

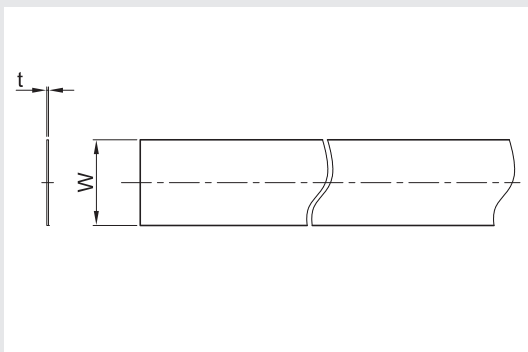

(Unit : mm)

Model	W	t
ST 15A	11	0.1
ST 20A	15	0.1
ST 25A	17	0.1
ST 30A	21	0.1
ST 35A	27	0.1
ST 45A	37	0.1
ST 55A	43	0.1
ST 65A	51	0.1

Ordering example : **ST15A - 1000L**

① ②

- ① Model number
- ② Length

Linear Rail System

SBI High-load Linear Rail System

Seal and MF container

[Method and overall length with each seal]

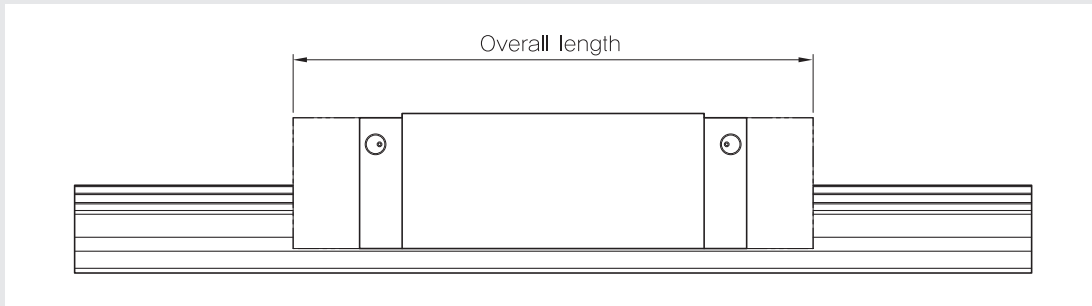

● E : End seal S : Scraper F : DF (High dust protection seal). MF (Self lubricant) (Unit : mm)

Additional seal	Standard	DD	ZZ	KK	D(M)F	D(M)FDD	D(M)FZZ	D(M)FKK	
Indication of seal	E	E+E	E+S	E+E+S	F+E	F+E+E	F+E+S	F+E+E+S	
Overall length with seal	15V	39.9	44.5	45.3	49.9	53.9	58.5	59.3	63.9
	15S	56.8	61.4	62.2	68.8	70.8	75.4	76.2	80.8
	15	63.8	68.4	69.2	73.8	77.8	82.4	83.2	87.8
	15L	79.4	84	84.8	89.4	93.4	98	98.8	103.4
	20V	49.1	54.1	54.5	59.5	63.1	68.1	68.5	73.5
	20S	65.2	70.2	70.6	75.6	-	-	-	-
	20	78.8	83.8	84.2	89.2	92.8	97.8	98.2	103.2
	20L	96.4	101.4	101.8	106.8	110.4	115.4	115.8	120.8
	25V	52.6	57.6	58	63	66.6	71.6	72	77
	25	92	97	97.4	102.4	106	111	111.4	116.4
	25L	108	113	113.4	118.4	122	127	127.4	132.4
	30	107.6	113.6	114	120	123.6	129.6	130	136
	30L	131.6	137.6	138	144	147.6	153.6	154	160
	35	124.6	130.6	131	137	140.6	146.6	147	153
	35L	152.6	158.6	159	165	168.6	174.6	175	181
	45	142	148	148.4	154.4	158	164	164.4	170.4
45L	174	180	180.4	186.4	190	196	196.4	202.4	
55	172.4	179.4	179.2	186.2	190.4	197.4	197.2	204.2	
55L	211.8	218.8	218.6	225.6	229.8	236.8	236.6	243.6	
65	219.8	226.8	226.6	233.6	237.8	244.8	244.6	251.6	
65L	272.2	279.2	279	286	290.2	297.2	297	304	

- Bottom seal of SBI type is integrated with bottom retainer. (Except SBI15)
- If block is assembled with MF container, the grease fitting is not supplied. If you would like to feed the grease to the block, please order side grease fitting type.

Linear Rail System

SBI High-load Linear Rail System

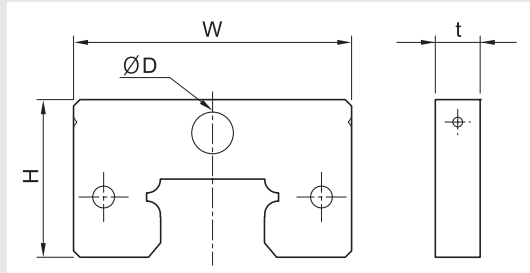

[Dimension of MF container]

(Unit : mm)

Reference	Model	Applied model	Block type	W	t	H	D
DF / MF	15A	SBI15	FL/FLL/HL/HLL/HLS SL/SLL/FV/SV	33.4	7	20.2	4
	20A	SBI20	FL/FLL SL/SLL	43.4	7	24.6	6.5
	20B		CL/CLL/FV/SV			22.6	
	25A	SBI25	FL/FLL/HL/HLL SL/SLL	47	7	29.7	6.5
	25B		CL/CLL/FV/SV			26.7	
	30A	SBI30	FL/FLL/HL/HLL SL/SLL	59	8	34.2	6.5
	35A	SBI35	FL/FLL/HL/HLL SL/SLL	69	8	39.7	6.5
	45A	SBI45	FL/FLL/HL/HLL SL/SLL	85	8	49.7	10.5
	55A	SBI55	FL/FLL/HL/HLL SL/SLL	98	9	56	10.5
	65A	SBI65	FL/FLL SL/SLL	123	9	69	10.5

(Unit : N)

[Seal resistance]

For the maximum value of seal resistance of SBI standard type per block, in which grease is not applied.

※ Scraper has no resistance because it is not contacting rail.

Model	End seal	DF	MF
SBI 15	2.0	4.7	3.5
SBI 20	2.5	4.9	3.0
SBI 25	3.0	5.5	3.5
SBI 30	3.9	5.6	3.5
SBI 35	2.5	5.7	3.7
SBI 45	3.4	5.9	4.1
SBI 55	3.5	6.2	4.2
SBI 65	3.6	6.4	4.4

Linear Rail System

SBI High-load Linear Rail System

HT high temperature end plate

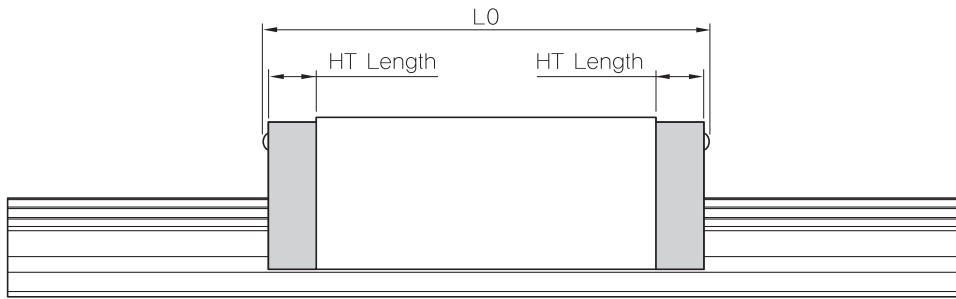

(Unit : mm)

Reference	HT Length	Overall length							
		Applied model	LO	Applied model	LO	Applied model	LO	Applied model	LO
HT 15A	6.5	SBI 15V	38.3	SBI 15S	53.2	SBI 15	62.2	SBI 15L	77.8
HT 20A	8	SBI 20V	47.1	SBI 20S	63.2	SBI 20	76.8	SBI 20L	94.4
HT 25A	8	SBI 25V	50.6	-	-	SBI 25	90	SBI 25L	106
HT 30A	10	-	-	-	-	SBI 30	105.6	SBI 30L	129.6
HT 35A	11	-	-	-	-	SBI 35	122.6	SBI 35L	150.6
HT 45A	13	-	-	-	-	SBI 45	140	SBI 45L	172
HT 55A	16	-	-	-	-	SBI 55	168.5	SBI 55L	207.9
HT 65A	20	-	-	-	-	SBI 65	215.9	SBI 65L	268.3

Ordering example : **SBI25FL - HT - 2 - K1 - 800 - N**

① ② ③ ④ ⑤ ⑥

- ① Model
- ② High temperature end plate
- ③ Block quantity
- ④ Preload
- ⑤ Rail length
- ⑥ Accuracy

- ※ All plastic components are replace with steel or aluminum in the High Temperature Blocks.
- ※ Side grease fitting is not available for high temperature end plates

Grease and nipple specification

[Grease]

SBI uses two types of grease according to working conditions.
For details, please see the technical data for grease.

㉓ Linear Rail System

㉔ Ball Screw

㉕ Support Unit

㉖ Linear Ball Bush

㉗ Cross Roller Guide

㉘ Robot Carrer Guide

Memo

Linear Rail System

SBI High-load Linear Rail System

(1) Standard grease fitting (Front grease fitting)

(Unit : mm)

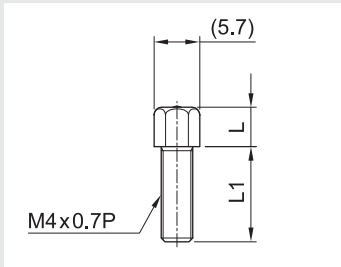

Specification		M4x0.7P		
Applied model	Grease fitting model	Symbol	L	L1
SBI 15	1N	None	7	5.5
	1D	DD, ZZ	5	9
	1Z	KK	5	11
	1F	DF,DFDD, DFZZ, DFKK	5	13

(Unit : mm)

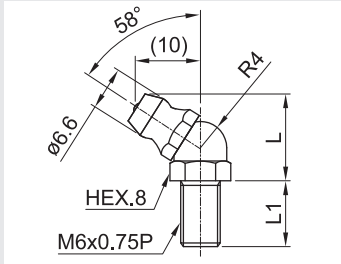

Specification		M6x0.75P, Asia type		
Applied model	Grease fitting model	Symbol	L	L1
SBI 20~35	IA2N	None	13.5	7
	IA2D	DD, ZZ	13.5	10
	IA2Z	KK, DF	13.5	13
	IA2F	DFDD, DFZZ, DFKK	13.5	18

(Unit : mm)

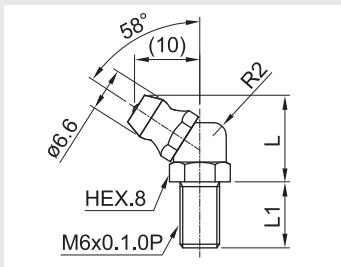

Specification		M6x1.0P, Europe type		
Applied model	Grease fitting model	Symbol	L	L1
SBI 20~35	IE2N	None	13.5	7
	IE2D	DD, ZZ	13.5	10
	IE2Z	KK, DF	13.5	13
	IE2F	DFDD, DFZZ, DFKK	13.5	18

(Unit : mm)

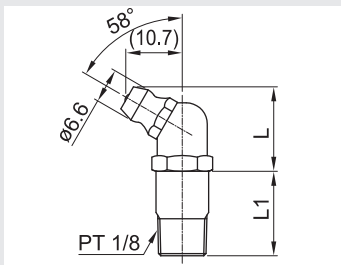

Specification		PT 1/8		
Applied model	Grease fitting model	Symbol	L	L1
SBI 45~65	4N	None	17	12
	4D	DD, KK, ZZ	17	16
	4F	DF, DFDD, DFZZ, DFKK	17	23

Linear Rail System

SBI High-load Linear Rail System

① Linear Rail System

② Ball Screw

③ Support Unit

④ Linear Ball Bush

⑤ Cross Roller Guide

⑥ Robot Carrer Guide

Memo

(2) Side grease fitting

Specification	M4x0.7P	Specification	M4x0.7P	Specification	M6x0.75P	Specification	PT1/8
Applied model	SBI 15	Applied model	SBI 20, 25	Applied model	SBI 30, 35, 45	Applied model	SBI 55, 65
Grease fitting model	S1N	Grease fitting model	S2N	Grease fitting model	S3N	Grease fitting model	S4N

(3) FS nipple connector for side grease fitting (FL, FLL flange type only) ※ Please see the page @/36 for assembling the nipple connector.

Specification	M4x0.7P	Specification	M4x0.7P	Specification	M6x0.75P
Applied model	SBI 15	Applied model	SBI 20, 25	Applied model	SBI 30, 35, 45
Grease fitting model	S1C	Grease fitting model	S2C	Grease fitting model	S4C

* For size 30~45, two pieces of FS nipple connector are applied.

(4) Copper pipe

Input size	PT1/8	Input size	PT1/8
Output size	M6x0.75P	Output size	PT1/8
Applied model	SBI 20, 25, 30, 35	Applied model	SBI 45, 55, 65
Grease fitting model	SB01	Grease fitting model	SB21

Linear Rail System

SBI High-load Linear Rail System

Ordering example

SBI20 **FL** - **N** - **MF** - **ZZ** - **K1**
 [1] [2] [3] [4] [5] [6]

[1] Model

[2] Block type : FL, FLL, FV, SL, SLL, SV, HL, HLS, HLL, CL, CLS, CLL

[3] Position of grease fitting : None (front), N (side)

[4] Container : No symbol (standard), DF (high dust protection), MF (self lubricant)

[5] Seal : No symbol (standard), DD, ZZ, KK

[6] Preload : K0, K1, K2, K3

※ "K3" Preload is not available for SBI 15 type

[Ordering example for rail]

SBI20 - **1000L** - **B**
 [1] [2] [3]

[1] Model

[2] Rail length

[3] Bottom mounting : No symbol (standard), B (bottom mounting rail)

※ If only rail is ordered, N grade is available.

Linear Rail System

SBI High-load Linear Rail System

[Ordering for assembled rail and block]

SBI20 FL - N - MF - ZZ - 2 - K1 - 800 - N - R - B - II
 [1] [2] [3] [4] [5] [6] [7] [8] [9] [10] [11] [12]

[1] Model

[2] Block type : FL, FLL, FV, SL, SLL, SV, HL, HLS, HLL, CL, CLS, CLL

[3] Position of grease fitting : None (front), N (side)

[4] Container : No symbol (standard), DF (high dust protection), MF (self lubricant)

[5] Seal : No symbol (standard), DD, ZZ, KK

[6] Block quantity on rail

[7] Preload : K0, K1, K2, K3

[8] Rail length

[9] Accuracy : N, H, P

[10] Surface treatment

[11] (B) Bottom mounting rail : No symbol (standard)

[12] Rail : number of rails per axis, 1=I, 2=II... 4=IV etc.

- ※ We recommend block and rail assembled to be ordered where high-precision and high-rigidity are required.
- ※ For surface treatment, please mark according to each surface treatment symbol.
- ※ If special G dimension is required, please mark when you place an order.
- ※ Please contact SBC for high temperature order.
- ※ "K3" Preload is not available for SBI 15 type

㉓ Linear Rail System

㉔ Ball Screw

㉕ Support Unit

㉖ Linear Ball Bush

㉗ Cross Roller Guide

㉘ Robot Carrer Guide

Memo

Linear Rail System

SBI High-load Linear Rail System

Standard and Max. Length of SBI rail

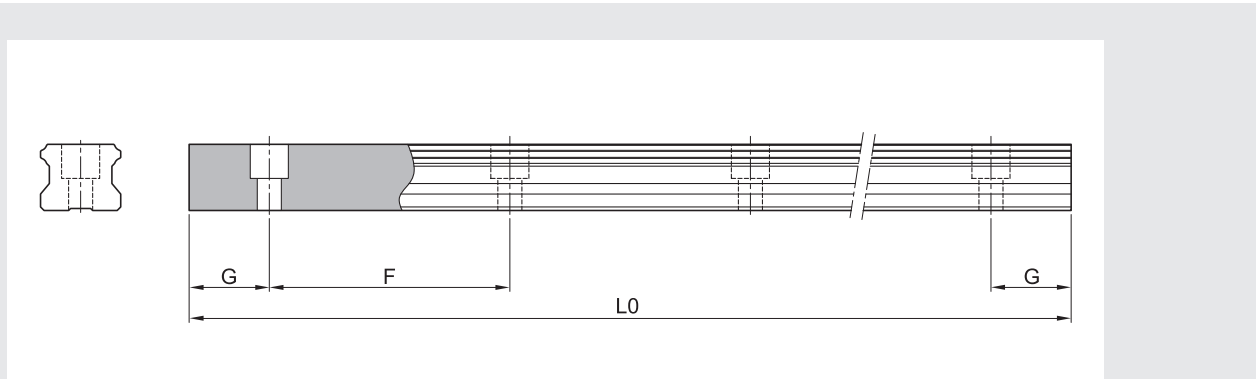

(Unit : mm)

Model number	SBI15	SBI20	SBI25	SBI30	SBI35	SBI45	SBI55	SBI65
Standard length	160	220	220	280	280	570	780	1270
	220	280	280	440	440	885	900	1570
	280	240	340	600	600	1095	1020	2020
	340	460	460	760	760	1200	1140	2470
	460	640	640	1000	1000	1410	1260	2620
	640	820	820	1240	1240	1620	1380	2920
	820	1000	1000	1480	1480	1830	1500	3070
	1000	1240	1240	1640	1640	2040	1620	-
	1240	1480	1480	1800	1800	2250	1740	-
	1480	1600	1600	2040	2040	2460	1860	-
	1600	1840	1840	2200	2200	2985	1980	-
	1960	2080	2080	2520	2520	3510	2220	-
	2200	2200	2200	2840	2840	-	2580	-
	2500	2500	2500	3000	3000	-	2940	-
	2860	2960	2980	3480	3480	-	3540	-
	-	3520	3520	-	-	-	-	-
-	4000	4000	-	-	-	-	-	
F	60	60	60	80	80	105	120	150
G	20	20	20	20	20	22.5	30	35
L0(Max length)	3,000	4,000	4,000	4,000	4,000	4,000	4,000	4,000

* If the maximum length exceeds this size, butt joints can be supplied.

* For more information about butt jointing, please refer to the page of safety design.

* If the G is not standard, please indicate it in the order sheet.

Linear Rail System

SBI High-load Linear Rail System

Bottom mounting rail (SBI-B type)

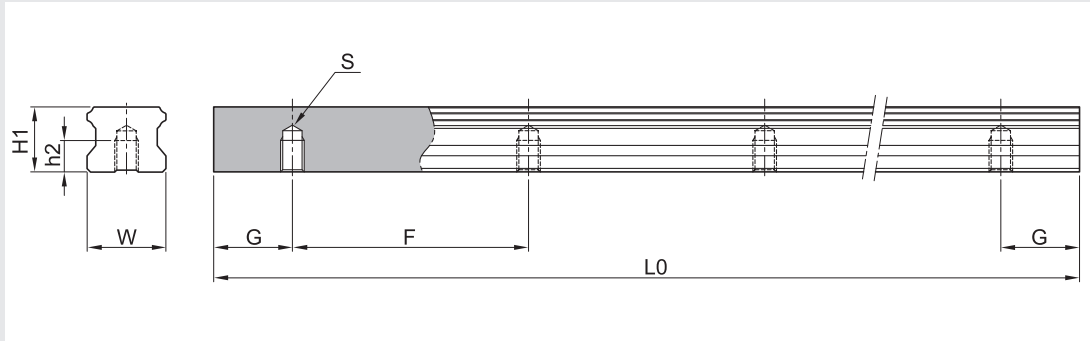

(Unit : mm)

Model number	W1	H1	S	h2	G	F	L0 (Max length)	Weight (kg/m)
SBI 15-B	15	13	M5X0.8	8	20	60	3,000	1.39
SBI 20-B	20	16.5	M6	9	20	60	4,000	2.37
SBI 25-B	23	20	M6	9	20	60	4,000	3.26
SBI 30-B	28	23	M8	12	20	80	4,000	4.63
SBI 35-B	34	26	M8	12	20	80	4,000	6.45
SBI 45-B	45	32	M12	18	22.5	105	4,000	10.49

* If the maximum length exceeds this size, please contact SBC.

㉓ Linear Rail System

㉔ Ball Screw

㉕ Support Unit

㉖ Linear Ball Bush

㉗ Cross Roller Guide

㉘ Robot Carrer Guide

Memo

Linear Rail System

SBI High-load Linear Rail System

SBI-FL/FLL

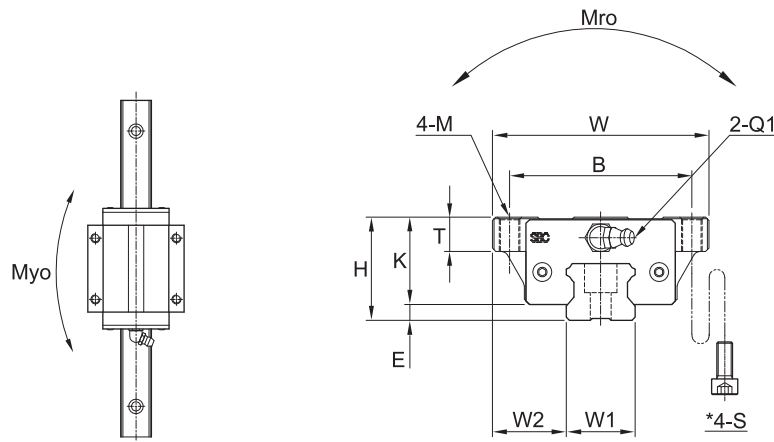

Model	Mounting dimension				Block dimensions												
	H	W	L	E	Mounting tap hole				L1	T±1	K	Grease fitting					
					B	J	M	*S				T1	N1	T2	N2	Q1	*Q2
SBI15 FL	24	47	63.8	3	38	30	M5	M4	45.2	9	21	4.5	5.5	3.8	3.8	M4x0.7	Ø3.5
SBI15 FLL	24	47	79.4	3	38	30	M5	M4	60.8	9	21	4.5	5.5	3.8	3.8	M4x0.7	Ø3.5
SBI20 FL	30	63	78.8	4.6	53	40	M6	M5	56.8	12	25.4	6	12	5.8	5	M6x0.75	Ø3.5
SBI20 FLL	30	63	96.4	4.6	53	40	M6	M5	74.4	12	25.4	6	12	5.8	5	M6x0.75	Ø3.5
SBI25 FL	36	70	92	5.5	57	45	M8	M6	70	14	30.5	6	12	5	5	M6x0.75	Ø3.5
SBI25 FLL	36	70	108	5.5	57	45	M8	M6	86	14	30.5	6	12	5	5	M6x0.75	Ø3.5
SBI30 FL	42	90	107.6	7	72	52	M10	M8	79.6	15.5	35	8.5	12	7.8	5	M6x0.75	Ø5.7
SBI30 FLL	42	90	131.6	7	72	52	M10	M8	103.6	15.5	35	8.5	12	7.8	5	M6x0.75	Ø5.7
SBI35 FL	48	100	124.6	7.5	82	62	M10	M8	94.6	15	40.5	8	12	8	6	M6x0.75	Ø5.7
SBI35 FLL	48	100	152.6	7.5	82	62	M10	M8	122.6	15	40.5	8	12	8	6	M6x0.75	Ø5.7
SBI45 FL	60	120	142	9	100	80	M12	M10	108	18	51	10.5	13.5	9.3	6.5	PT1/8	Ø5.7
SBI45 FLL	60	120	174	9	100	80	M12	M10	140	18	51	10.5	13.5	9.3	6.5	PT1/8	Ø5.7
SBI55 FL	70	140	172.4	12	116	95	M14	M12	131	22	58	12	13	12	8	PT1/8	Ø8.7
SBI55 FLL	70	140	211.8	12	116	95	M14	M12	170.4	22	58	12	13	12	8	PT1/8	Ø8.7
SBI65 FL	90	170	219.8	19	142	110	M16	M14	170.4	26	71	14	13	14	10	PT1/8	Ø8.7
SBI65 FLL	90	170	272.2	19	142	110	M16	M14	222.8	26	71	14	13	14	10	PT1/8	Ø8.7

① C (Basic dynamic load rating), Co (Basic static load rating)

② *S: Bolt size for bottom mounting type of block.

Linear Rail System

SBI High-load Linear Rail System

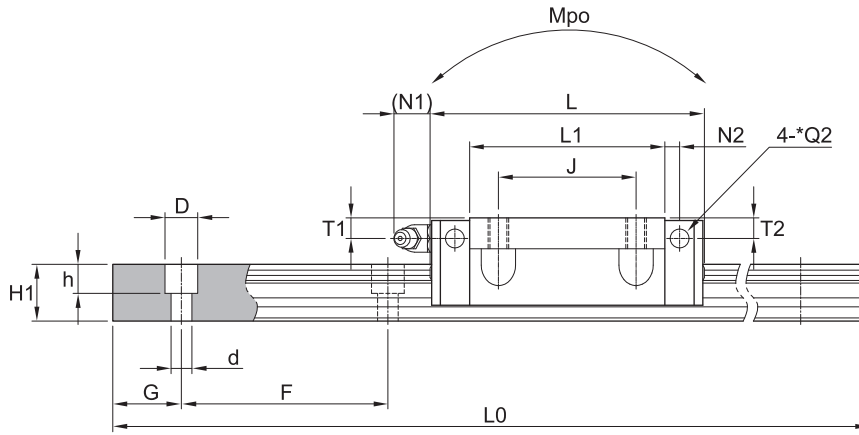

(Unit : mm)

Rail dimension									Basic load rating [kN]		Permissible static moment [kN·m]			Mass	
W1	W2	H1	F	Bolt hole			G	Max length of rail L0	C	Co	Mro	Mpo	Myo	Block [kg]	Rail [kg/m]
				d	D	h									
15	16	13	60	4.5	7.5	5.5	20	3000	14.1	24.1	0.16	0.17	0.17	0.19	1.3
15	16	13	60	4.5	7.5	5.5	20	3000	17.1	31.7	0.21	0.29	0.29	0.26	1.3
20	21.5	16.5	60	6	9.5	8.5	20	4000	22.2	38.2	0.36	0.33	0.33	0.41	2.2
20	21.5	16.5	60	6	9.5	8.5	20	4000	27.9	50	0.47	0.56	0.56	0.54	2.2
23	23.5	20	60	7	11	9	20	4000	31.5	52.1	0.56	0.56	0.56	0.69	3
23	23.5	20	60	7	11	9	20	4000	36.7	64.4	0.69	0.84	0.84	0.85	3
28	31	23	80	9	14	12	20	4000	42.8	65.4	0.85	0.77	0.77	1.04	4.25
28	31	23	80	9	14	12	20	4000	51.3	84.7	1.10	1.30	1.30	1.37	4.25
34	33	26	80	9	14	12	20	4000	59.5	89.1	1.42	1.28	1.28	1.56	6.02
34	33	26	80	9	14	12	20	4000	71.3	115.3	1.83	2.12	2.12	2.04	6.02
45	37.5	32	105	14	20	17	22.5	4000	79.2	116.3	2.48	1.90	1.90	2.80	9.77
45	37.5	32	105	14	20	17	22.5	4000	94.8	150.5	3.21	3.14	3.14	3.69	9.77
53	43.5	38	120	16	23	20	30	4000	127.3	181.8	4.81	2.97	2.97	4.42	13.72
53	43.5	38	120	16	23	20	30	4000	147.9	224.5	5.95	4.78	4.78	5.82	13.72
63	53.5	53	150	18	26	22	35	4000	188.3	261.7	8.24	5.57	5.57	9.1	23.17
63	53.5	53	150	18	26	22	35	4000	232.5	354.1	11.15	9.86	9.86	11.98	23.17

③ *Q2: The hole of side grease nipple is not made to prevent a foreign substance from going into inside.
When you order the side grease nipple, we build it by ourselves.

Linear Rail System

SBI High-load Linear Rail System

SBI-SL/SLL

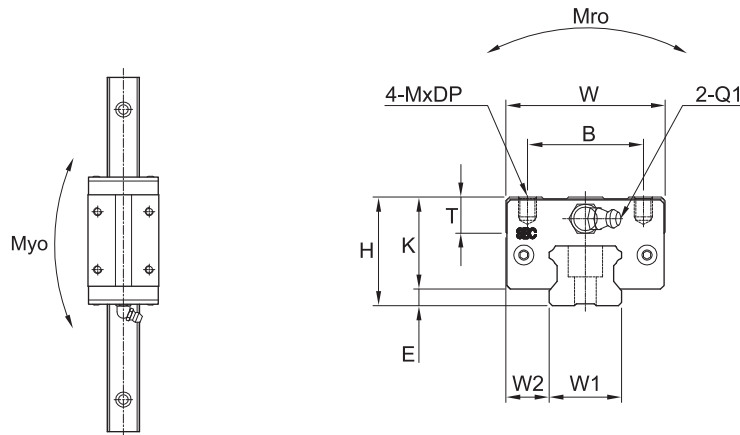

Model	Mounting dimension				Block dimensions												
	H	W	L	E	Mounting tap hole				L1	T±1	K	Grease fitting					
					B	J	M	DP				T1	N1	T2	N2	Q1	*Q2
SBI15 SL	28	34	63.8	3	26	26	M4	5	45.2	10	25	8.5	5.5	7.8	3.8	M4x0.7	Ø3.5
SBI15 SLL	28	34	79.4	3	26	34	M4	5	60.8	10	25	8.5	5.5	7.8	3.8	M4x0.7	Ø3.5
SBI20 SL	30	44	78.8	4.6	32	36	M5	5	56.8	10	25.4	6	12	5.8	5	M6x0.75	Ø3.5
SBI20 SLL	30	44	96.4	4.6	32	50	M5	5	74.4	10	25.4	6	12	5.8	5	M6x0.75	Ø3.5
SBI25 SL	40	48	92	5.5	35	35	M6	8	70	16	34.5	10	12	9	5	M6x0.75	Ø3.5
SBI25 SLL	40	48	108	5.5	35	50	M6	8	86	16	34.5	10	12	9	5	M6x0.75	Ø3.5
SBI30 SL	45	60	107.6	7	40	40	M8	10	79.6	12	38	11.5	12	10.8	5	M6x0.75	Ø5.7
SBI30 SLL	45	60	131.6	7	40	60	M8	10	103.6	12	38	11.5	12	10.8	5	M6x0.75	Ø5.7
SBI35 SL	55	70	124.6	7.5	50	50	M8	10	94.6	15	47.5	15	12	15	6	M6x0.75	Ø5.7
SBI35 SLL	55	70	152.6	7.5	50	72	M8	10	122.6	15	47.5	15	12	15	6	M6x0.75	Ø5.7
SBI45 SL	70	86	142	9	60	60	M10	13	108	17	61	20.5	13.5	19.3	6.5	PT1/8	Ø5.7
SBI45 SLL	70	86	174	9	60	80	M10	13	140	17	61	20.5	13.5	19.3	6.5	PT1/8	Ø5.7
SBI55 SL	80	100	172.4	12	75	75	M12	18	131	21	68	22	13	22	8	PT1/8	Ø8.7
SBI55 SLL	80	100	211.8	12	75	95	M12	18	170.4	21	68	22	13	22	8	PT1/8	Ø8.7
SBI65 SL	90	126	219.8	19	76	70	M16	16	170.4	26	71	14	13	14	10	PT1/8	Ø8.7
SBI65 SLL	90	126	272.2	19	76	120	M16	16	222.8	26	71	14	13	14	10	PT1/8	Ø8.7

① C (Basic dynamic load rating), Co (Basic static load rating)

② *Q2: The hole of side grease nipple is not made to prevent a foreign substance from going into inside.
When you order the side grease nipple, we build it by ourselves.

Linear Rail System

SBI High-load Linear Rail System

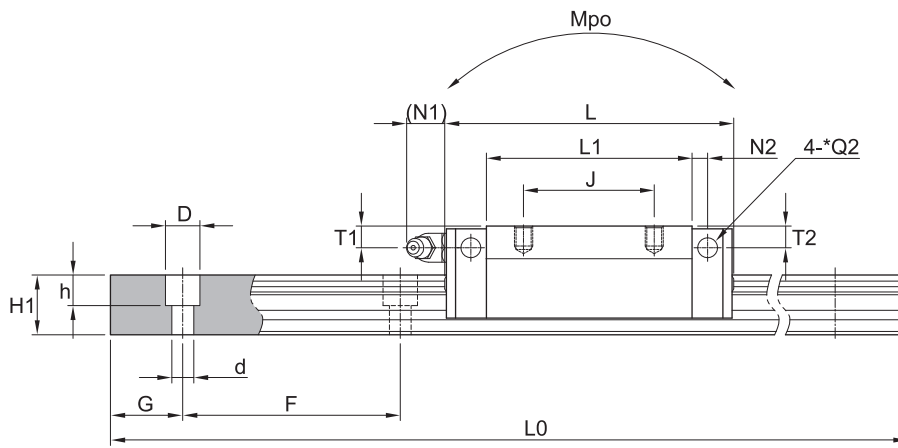

(Unit : mm)

Rail dimension									Basic load rating		Permissible static moment			Mass	
W1	W2	H1	F	Bolt hole			G	Max length of rail L0	C	Co	Mro	Mpo	Myo	Block [kg]	Rail [kg/m]
				d	D	h									
15	9.5	13	60	4.5	7.5	5.5	20	3000	14.1	24.1	0.16	0.17	0.17	0.19	1.3
15	9.5	13	60	4.5	7.5	5.5	20	3000	17.1	31.7	0.21	0.29	0.29	0.26	1.3
20	12	16.5	60	6	9.5	8.5	20	4000	22.2	38.2	0.36	0.33	0.33	0.41	2.2
20	12	16.5	60	6	9.5	8.5	20	4000	27.9	50	0.47	0.56	0.56	0.54	2.2
23	12.5	20	60	7	11	9	20	4000	31.5	52.1	0.56	0.56	0.56	0.69	3
23	12.5	20	60	7	11	9	20	4000	36.7	64.4	0.69	0.84	0.84	0.85	3
28	16	23	80	9	14	12	20	4000	42.8	65.4	0.85	0.77	0.77	1.04	4.25
28	16	23	80	9	14	12	20	4000	51.3	84.7	1.10	1.30	1.30	1.37	4.25
34	18	26	80	9	14	12	20	4000	59.5	89.1	1.42	1.28	1.28	1.56	6.02
34	18	26	80	9	14	12	20	4000	71.3	115.3	1.83	2.12	2.12	2.04	6.02
45	20.5	32	105	14	20	17	22.5	4000	79.2	116.3	2.48	1.90	1.90	2.80	9.77
45	20.5	32	105	14	20	17	22.5	4000	94.8	150.5	3.21	3.14	3.14	3.69	9.77
53	23.5	38	120	16	23	20	30	4000	127.3	181.8	4.81	2.97	2.97	4.42	13.72
53	23.5	38	120	16	23	20	30	4000	147.9	224.5	5.95	4.78	4.78	5.82	13.72
63	31.5	53	150	18	26	22	35	4000	188.3	261.7	8.24	5.57	5.57	9.1	23.17
63	31.5	53	150	18	26	22	35	4000	232.5	354.1	11.15	9.86	9.86	11.98	23.17

① Linear Rail System

② Ball Screw

③ Support Unit

④ Linear Ball Bush

⑤ Cross Roller Guide

⑥ Robot Carrer Guide

Memo

Linear Rail System

SBI High-load Linear Rail System

SBI-HL/HLS/HLL

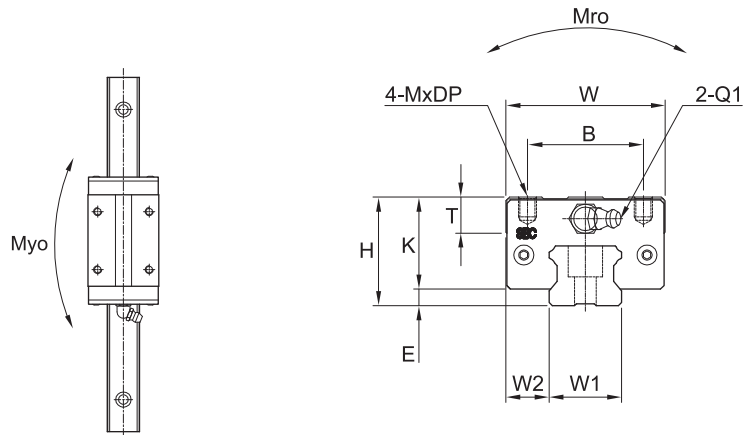

Model	Mounting dimension				Block dimensions												
	H	W	L	E	Mounting tap hole				L1	T±1	K	Grease fitting					
					B	J	M	DP				T1	N1	T2	N2	Q1	*Q2
SBI15 HL	24	34	63.8	3	26	26	M4	4	45.2	6	21	4.5	5.5	3.8	3.8	M4x0.7	Ø3.5
SBI15 HLS	24	34	56.8	3	26	26	M4	4	38.2	6	21	4.5	5.5	3.8	3.8	M4x0.7	Ø3.5
SBI15 HLL	24	34	79.4	3	26	34	M4	4	60.8	6	21	4.5	5.5	3.8	3.8	M4x0.7	Ø3.5
SBI25 HL	36	48	92	5.5	35	35	M6	6	70	12	30.5	6	12	5	5.5	M6x0.75	Ø3.5
SBI25 HLL	36	48	108	5.5	35	50	M6	6	86	12	30.5	6	12	5	5.5	M6x0.75	Ø3.5
SBI30 HL	42	60	107.6	7	40	40	M8	8	79.6	12	35	8.5	12	7.8	5	M6x0.75	Ø5.7
SBI30 HLL	42	60	131.6	7	40	60	M8	8	103.6	12	35	8.5	12	7.8	5	M6x0.75	Ø5.7
SBI35 HL	48	70	124.6	7.5	50	50	M8	8	94.6	15	40.5	8	12	8	6	M6x0.75	Ø5.7
SBI35 HLL	48	70	152.6	7.5	50	72	M8	8	122.6	15	40.5	8	12	8	6	M6x0.75	Ø5.7
SBI45 HL	60	86	142	9	60	60	M10	10	108	17	51	10.5	13.5	9.3	6.5	PT1/8	Ø5.7
SBI45 HLL	60	86	174	9	60	80	M10	10	140	17	51	10.5	13.5	9.3	6.5	PT1/8	Ø5.7
SBI55 HL	70	100	172.4	12	75	75	M12	12	131	21	58	12	13	12	8	PT1/8	Ø8.7
SBI55 HLL	70	100	211.8	12	75	95	M12	12	170.4	21	58	12	13	12	8	PT1/8	Ø8.7

- ① C (Basic dynamic load rating), Co (Basic static load rating)
- ② *Q2: The hole of side grease nipple is not made to prevent a foreign substance from going into inside.
When you order the side grease nipple, we build it by ourselves.

Linear Rail System

SBI High-load Linear Rail System

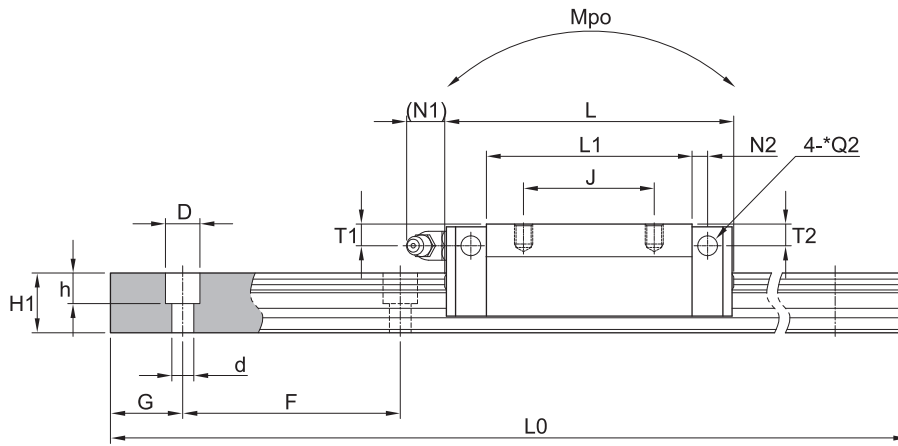

(Unit : mm)

Rail dimension									Basic load rating		Permissible static moment			Mass	
W1	W2	H1	F	Bolt hole			G	Max length of rail L0	C	Co	Mro	Mpo	Myo	Block [kg]	Rail [kg/m]
				d	D	h									
15	9.5	13	60	4.5	7.5	5.5	20	3000	14.1	24.1	0.16	0.17	0.17	0.19	1.3
15	9.5	13	60	4.5	7.5	5.5	20	3000	12.3	18.3	0.13	0.08	0.08	0.15	1.3
15	9.5	13	60	4.5	7.5	5.5	20	3000	17.1	31.7	0.21	0.29	0.29	0.26	1.3
23	12.5	20	60	7	11	9	20	4000	31.5	52.1	0.56	0.56	0.56	0.69	3
23	12.5	20	60	7	11	9	20	4000	36.7	64.4	0.69	0.84	0.84	0.85	3
28	16	23	80	9	14	12	20	4000	42.8	65.4	0.85	0.77	0.77	1.04	4.25
28	16	23	80	9	14	12	20	4000	51.3	84.7	1.10	1.30	1.30	1.37	4.25
34	18	26	80	9	14	12	20	4000	59.5	89.1	1.42	1.28	1.28	1.56	6.02
34	18	26	80	9	14	12	20	4000	71.3	115.3	1.83	2.12	2.12	2.04	6.02
45	20.5	32	105	14	20	17	22.5	4000	79.2	116.3	2.48	1.90	1.90	2.80	9.77
45	20.5	32	105	14	20	17	22.5	4000	94.8	150.5	3.21	3.14	3.14	3.69	9.77
53	23.5	38	120	16	23	20	30	4000	127.3	181.8	4.81	2.97	2.97	4.42	13.72
53	23.5	38	120	16	23	20	30	4000	147.9	224.5	5.95	4.78	4.78	5.82	13.72

Ⓐ Linear Rail System

Ⓑ Ball Screw

Ⓒ Support Unit

Ⓓ Linear Ball Bush

Ⓔ Cross Roller Guide

Ⓕ Robot Carrier Guide

Memo

Linear Rail System

SBI High-load Linear Rail System

SBI-CL/CLS/CLL

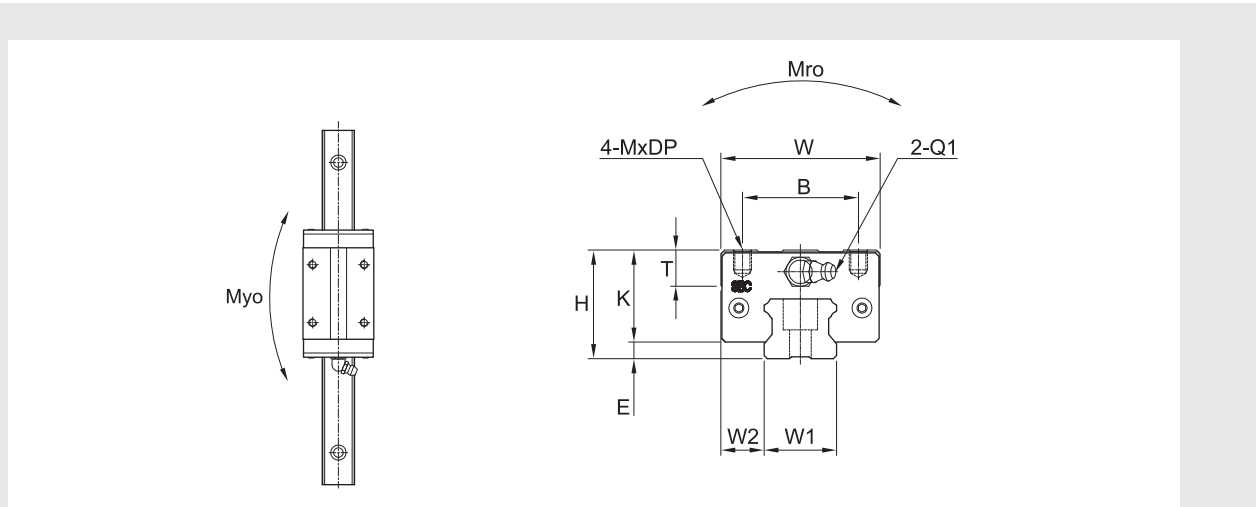

Model	Mounting dimension				Block dimensions												
	H	W	L	E	Mounting tap hole				L1	T	K	Grease fitting					
					B	J	M	DP				T1	N1	T2	N2	Q1	*Q2
SBI20 CL	28	44	78.8	4.6	32	32	M5	5	56.8	7.8	23.4	4.8	12	4	5	M6x0.75	Ø3.5
SBI20 CLS	28	42	65.5	4.6	32	32	M5	5	43.2	7.8	23.4	4.8	12	4.3	5	M6x0.75	Ø3.5
SBI20 CLL	28	44	96.4	4.6	32	50	M5	5	74.4	7.8	23.4	4.8	12	4	5	M6x0.75	Ø3.5
SBI25 CL	33	48	92	5.5	35	35	M6	6	70	9	27.5	5.4	12	5.4	5	M6x0.75	Ø3.5
SBI25 CLL	33	48	108	5.5	35	50	M6	6	86	9	27.5	5.4	12	5.4	5	M6x0.75	Ø3.5

- ① C (Basic dynamic load rating), Co (Basic static load rating)
- ② *Q2: The hole of side grease nipple is not made to prevent a foreign substance from going into inside.
When you order the side grease nipple, we build it by ourselves.

Linear Rail System

SBI High-load Linear Rail System

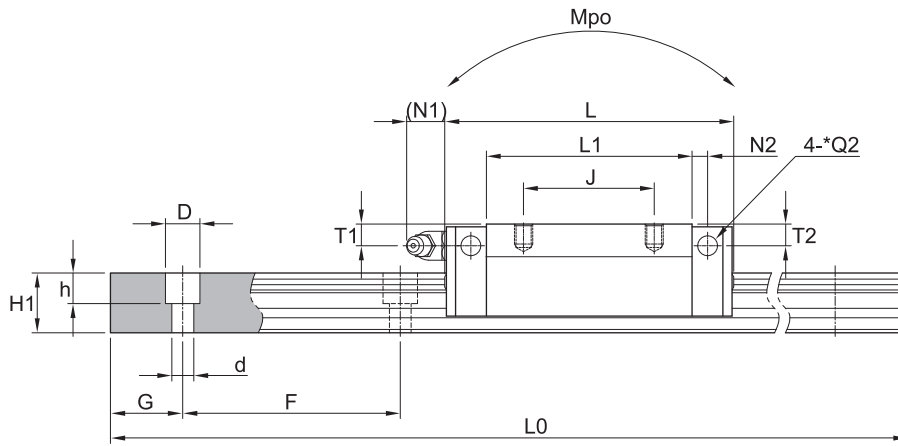

(Unit : mm)

Rail dimension									Basic load rating [kN]		Permissible static moment [kN·m]			Mass	
W1	W2	H1	F	Bolt hole			G	Max length of rail L0	C	Co	Mro	Mpo	Myo	Block [kg]	Rail [kg/m]
				d	D	h									
20	12	16.5	60	6	9.5	8.5	20	4000	22.2	38.2	0.36	0.33	0.33	0.39	2.2
20	11	16.5	60	6	9.5	8.5	20	4000	19.1	27.0	0.27	0.15	0.15	0.23	2.2
20	12	16.5	60	6	9.5	8.5	20	4000	27.9	50	0.47	0.56	0.56	0.52	2.2
23	12.5	20	60	7	11	9	20	4000	31.5	52.1	0.56	0.56	0.56	0.66	3
23	12.5	20	60	7	11	9	20	4000	36.7	64.4	0.69	0.84	0.84	0.82	3

㉑ Linear Rail System

㉒ Ball Screw

㉓ Support Unit

㉔ Linear Ball Bush

㉕ Cross Roller Guide

㉖ Robot Carrer Guide

Memo

Linear Rail System

SBI High-load Linear Rail System

SBI-FV

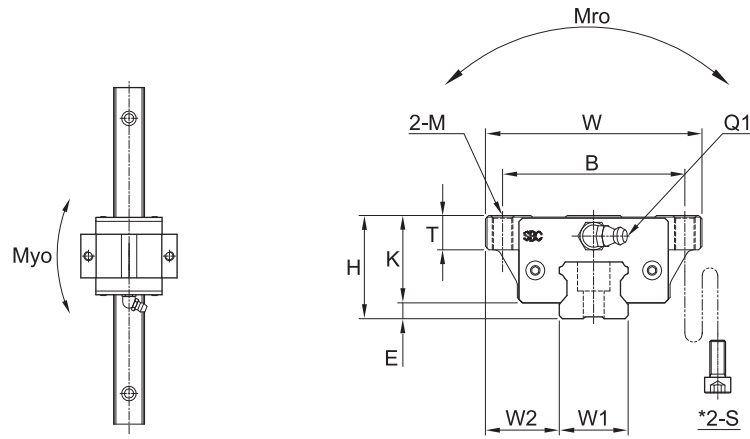

Model	Mounting dimension				Block dimensions											
	H	W	L	E	Mounting tap hole			L1	T	K	Grease fitting					
					B	M	*S				T1	N1	T2	N2	Q1	*Q2
SBI15 FV	24	47	39.9	3	38	M5	M4	21.3	8.8	21	4.5	5.5	3.8	3.4	M4x0.7	Ø3.5
SBI20 FV	28	63	49.1	4.5	53	M6	M5	27.1	8	23.4	4.8	12	4	5	M6x0.75	Ø3.5
SBI25 FV	33	70	52.6	5.5	57	M8	M6	30.6	9	27.5	5.4	12	5.4	5	M6x0.75	Ø3.5

- ① C (Basic dynamic load rating), Co (Basic static load rating)
- ② *S: Bolt size for bottom mounting type of block.
- ③ *Q2: The hole of side grease nipple is not made to prevent a foreign substance from going into inside.
When you order the side grease nipple, we build it by ourselves.

Linear Rail System

SBI High-load Linear Rail System

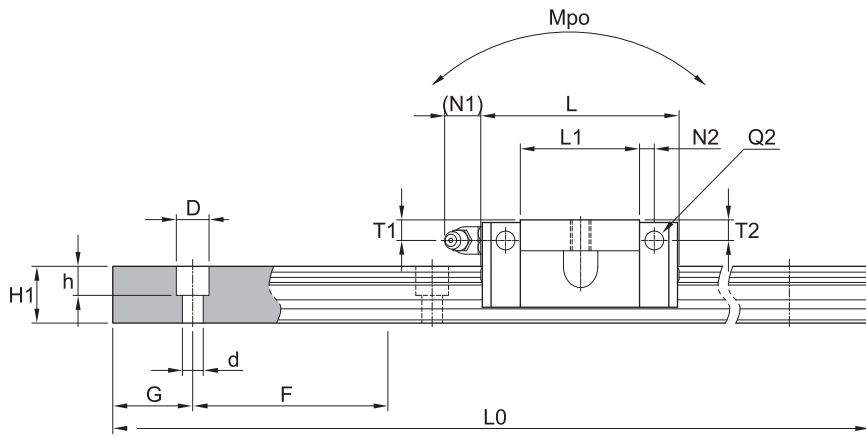

(Unit : mm)

Rail dimension									Basic load rating		Permissible static moment			Mass	
W1	W2	H1	F	Bolt hole			G	Max length of rail L0	C	Co	Mro	Mpo	Myo	Block [kg]	Rail [kg/m]
				d	D	h									
15	16	13	60	4.5	7.5	5.5	20	3000	5.8	12.8	0.04	0.03	0.03	0.10	1.3
20	21.5	16.5	60	6	9.5	8.5	20	4000	9.4	20.2	0.12	0.10	0.10	0.24	2.2
23	23.5	20	60	7	11	9	20	4000	12.4	26.1	0.19	0.17	0.17	0.37	3

㉓ Linear Rail System

㉔ Ball Screw

㉕ Support Unit

㉖ Linear Ball Bush

㉗ Cross Roller Guide

㉘ Robot Carrer Guide

Memo

Linear Rail System

SBI High-load Linear Rail System

SBI-SV

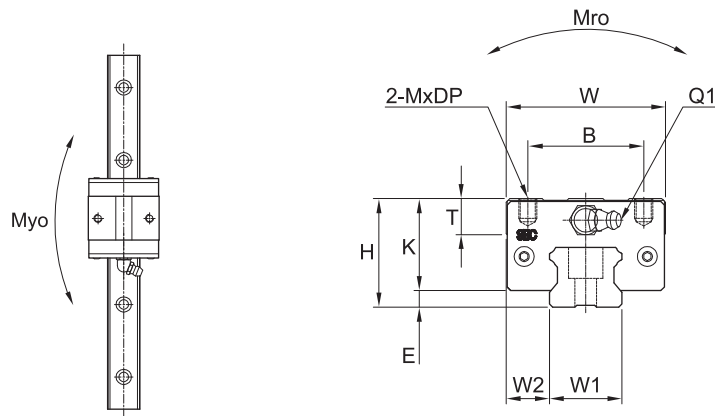

Model	Mounting dimension				Block dimensions											
	H	W	L	E	Mounting tap hole			L1	T	K	Grease fitting					
					B	M	DP				T1	N1	T2	N2	Q1	*Q2
SBI15 SV	24	34	39.9	3	26	M4	4	21.3	6	21	4.5	5.5	3.8	3.4	M4x0.7	Ø3.5
SBI20 SV	28	44	49.1	4.6	32	M5	5	27.1	7.8	23.4	4.8	12	4	5	M6x0.75	Ø3.5
SBI25 SV	33	48	52.6	5.5	35	M6	6	30.6	9	27.5	5.4	12	5.4	5	M6x0.75	Ø3.5

- ① C (Basic dynamic load rating), Co (Basic static load rating)
- ② *Q2: The hole of side grease nipple is not made to prevent a foreign substance from going into inside.
When you order the side grease nipple, we build it by ourselves.

Linear Rail System

SBI High-load Linear Rail System

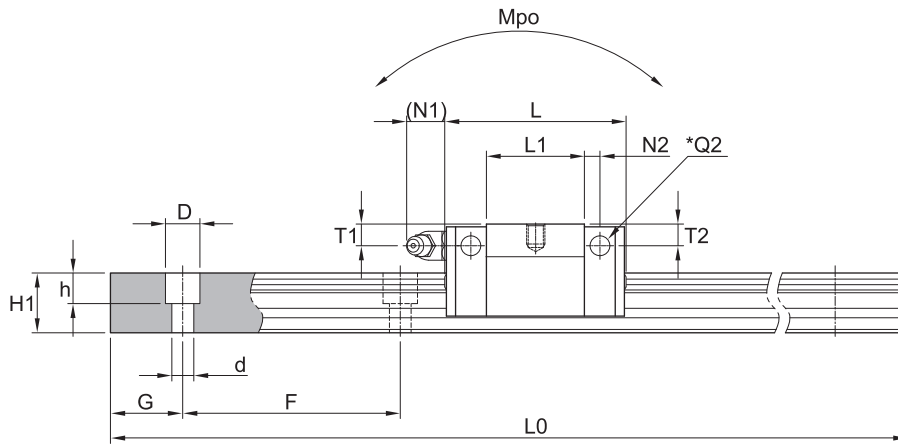

(Unit : mm)

Rail dimension									Basic load rating [kN]		Permissible static moment [kN·m]			Mass	
W1	W2	H1	F	Bolt hole			G	Max length of rail L0	C	Co	Mro	Mpo	Myo	Block [kg]	Rail [kg/m]
				d	D	h									
15	9.5	13	60	4.5	7.5	5.5	20	3000	5.8	12.8	0.04	0.03	0.03	0.10	1.3
20	12	16.5	60	6	9.5	8.5	20	4000	9.4	20.2	0.12	0.10	0.10	0.24	2.2
23	12.5	20	60	7	11	9	20	4000	12.4	26.1	0.19	0.17	0.17	0.37	3

㉓ Linear Rail System

㉔ Ball Screw

㉕ Support Unit

㉖ Linear Ball Bush

㉗ Cross Roller Guide

㉘ Robot Carrer Guide

Memo

Linear Rail System

SBG Standard Linear Rail System

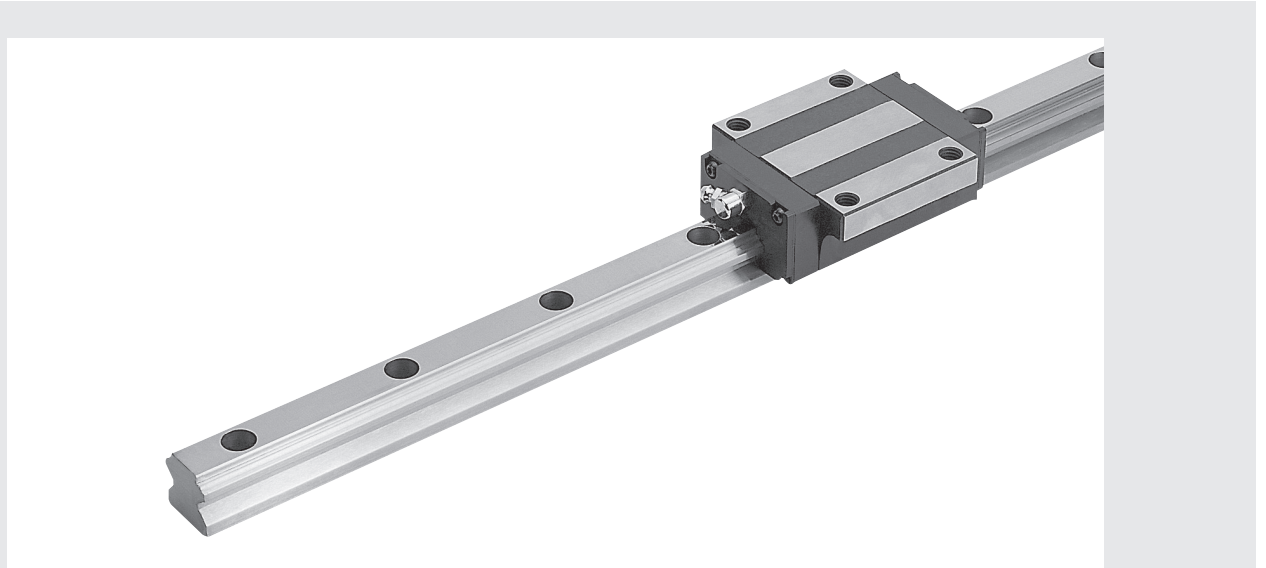

Circular arc groove

Two pint contact structure of circular arc groove. It keeps the function of self-aligning and smooth rolling performance.

45° angle of contact

Four rows of circular arc groove contact balls at an angle of 45 degree. It provides the same load capacity in all directions.

DF structure

The same dimension

Linear Rail System

SBG Standard Linear Rail System

The Block Structure

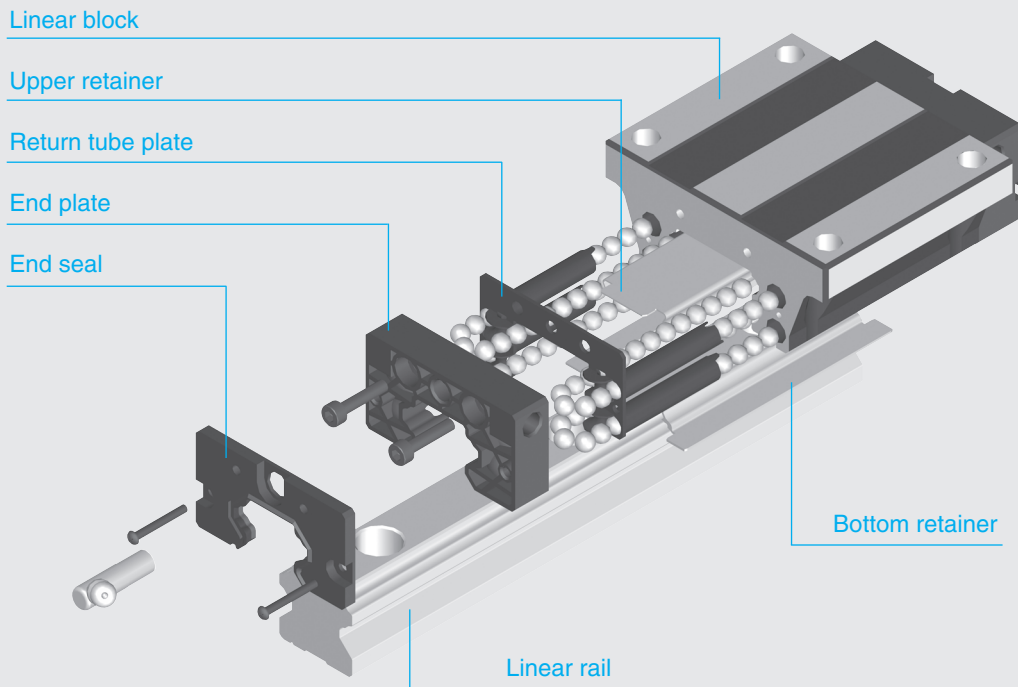

Linear rail The same rail profile may be used for every type of block (SBG, SBS, SPG and SPS). SBC uses only high strength and heat-treated special steels in all rails.

End seal New double lip structure which improves resistance to dust and particle contamination.

Linear block SBG, SBS, SPG and SPS types are available. All blocks are dimensionally interchangeable.

㉓ Linear Rail System

㉔ Ball Screw

㉕ Support Unit

㉖ Linear Ball Bush

㉗ Cross Roller Guide

㉘ Robot Carrier Guide

Memo

Linear Rail System

SBG Standard Linear Rail System

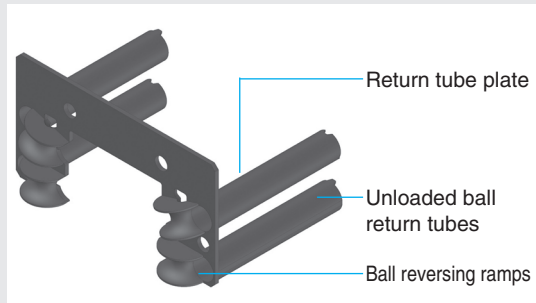

(Structure of return tube plate)

Single component Return tube & reversing plate structure Inserting a molded tube into the ball return paths keeps lubricant cleaner by providing better loose ball control and free lubricant flow while preventing metal to metal skidding contact with what is normally an imprecise return path wall.

※ Return tube plate is available for SBG(S), SPG(S) 20~35.

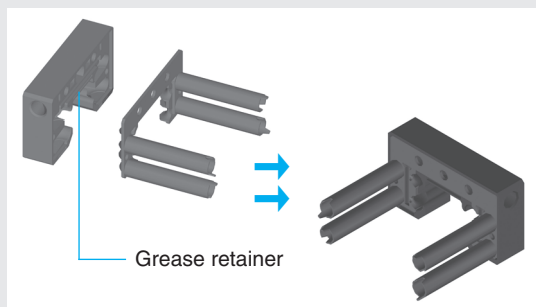

(Close fitting end-plate reduces grease loss)



(Snap assembled)

Retainer Ball retainers are snap assembled to the internal body and end-plate without fixed position screws. The retainers can self align according to load orientation and direct the balls smoothly into the load zone. This function eliminates ball skid and hot zone pre-load creating smoother running and longer life. These new retainers are made of stainless steel (SUS304) and are corrosion resistant.

Bottom retainer is one body type with rubber seal to prevent contamination from bottom.

※ Bottom seal is not available for size 15 of SBG(S), SPG(S).

Linear Rail System

SBG Standard Linear Rail System

SBG type

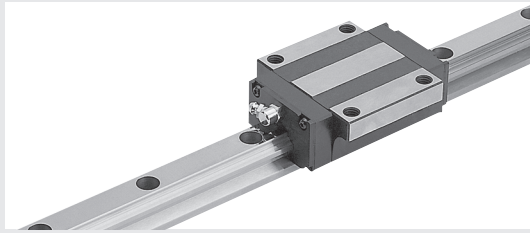

SBG is SBC standard linear block and FL, FLL, SL, SLL are available.

SBG-FL/FLL

-Flange type
-Size 15~65

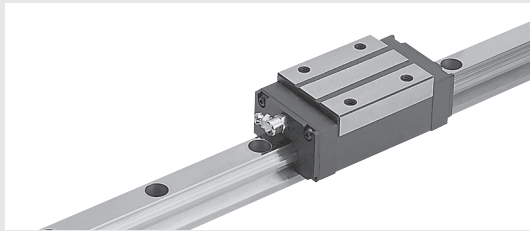

SBG-SL/SLL

-Slim type
-Size 15~65

SBS type

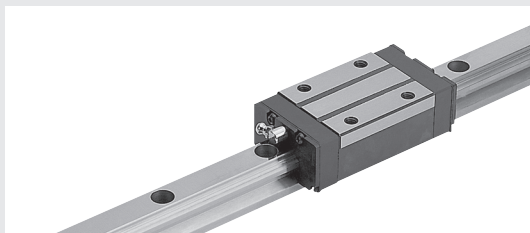

SBS type use same rail as SBG rail and the height is lower than SBG-SL type.

SBS-SL/SLL

-Slim type
-Size 15~45

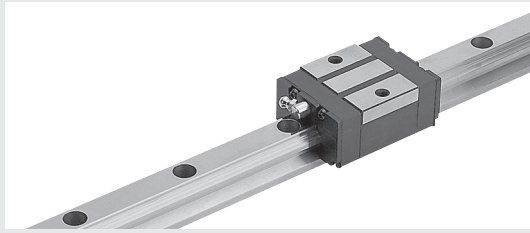

SBS-HL/HLL

-SBS-SL (Height is higher than SBS-SL/SLL type)
-Size 25

SBS-FV

-Flange type with shorter length
-Size 15~25

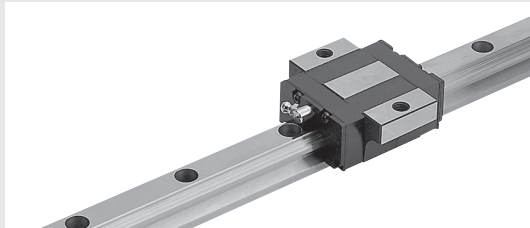

SBS-SV

-Slim type with shorter length
-Size 15~25

㉓ Linear Rail System

㉔ Ball Screw

㉕ Support Unit

㉖ Linear Ball Bush

㉗ Cross Roller Guide

㉘ Robot Carrer Guide

Memo

Linear Rail System

SBG Standard Linear Rail System

Accuracy

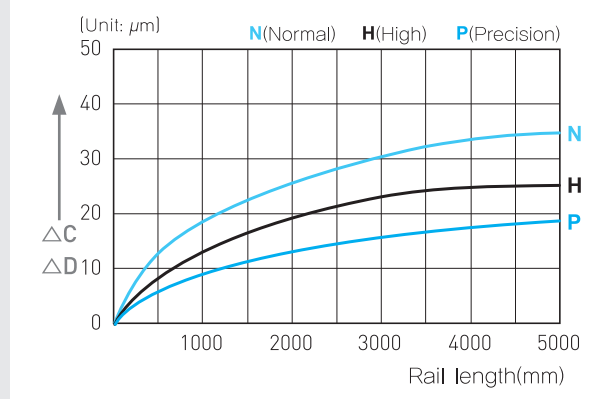
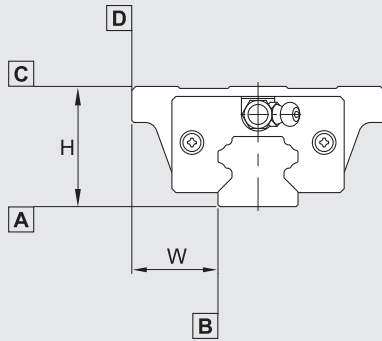

(Unit : mm)

Item	N	H	P
Tolerance for the height H	±0.1	±0.04	±0.02
Tolerance for the rail-to-block lateral distance W2	±0.1	±0.04	±0.02
Tolerance for the height H difference among blocks	0.03	0.015	0.007
Tolerance for rail-to-block lateral distance W2 distance among blocks	0.03	0.015	0.007
Running parallelism of surface C with surface A	ΔC		
Running parallelism of surface D with surface B	ΔD		

● N : Normal ● H : High ● P : Precision

Preload

Reference	Volume of preload
K1 (Normal)	Max. 0.02C
K2 (Light)	0.04 ~ 0.06C
K3 (Heavy)	0.08 ~ 0.10C

● C(kN) : Basic dynamic load rating

※ "K3" Preload is not available for SBG, SBS 15 type

Linear Rail System

SBG Standard Linear Rail System

Shoulder height and fillet radius R

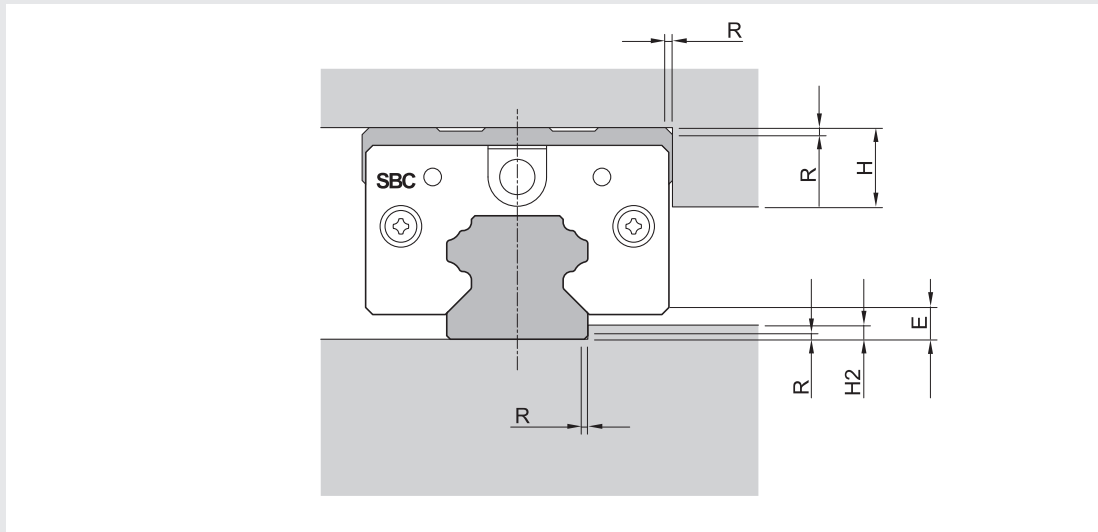

(Unit : mm)

Model number	Fillet radius R	Shoulders height H1	Shoulders height H2	E
15	0.5	4	2	3
20	0.5	5	2.5	3.5
25	1.0	5	3.5	6.5
30	1.0	5	4.5	7
35	1.0	6	6	7.5
45	1.0	8	8	10
55	1.5	8	8	13
65	1.5	10	10	17.5

㉓ Linear Rail System

㉔ Ball Screw

㉕ Support Unit

㉖ Linear Ball Bush

㉗ Cross Roller Guide

㉘ Robot Carrer Guide

Memo

Linear Rail System

SBG Standard Linear Rail System

Permissible tolerance (P) of parallelism

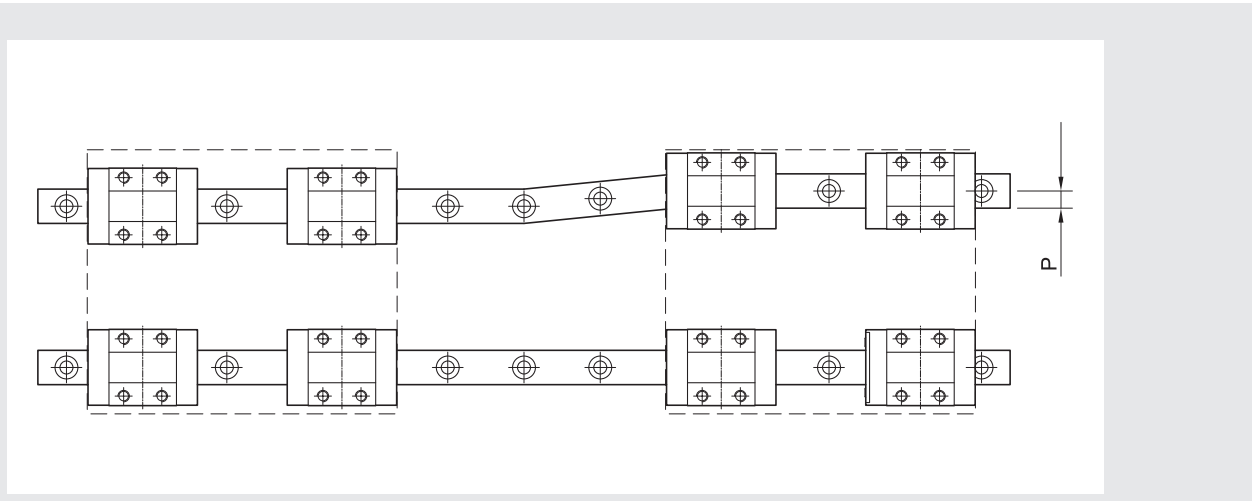

(Unit : mm)

Model size	K1	K2	K3
15	0.025	0.018	-
20	0.025	0.02	0.018
25	0.03	0.022	0.02
30	0.04	0.03	0.027
35	0.05	0.035	0.03
45	0.06	0.04	0.035
55	0.07	0.05	0.045
65	0.08	0.06	0.055

Linear Rail System

SBG Standard Linear Rail System

Permissible tolerance (S) of two level offset

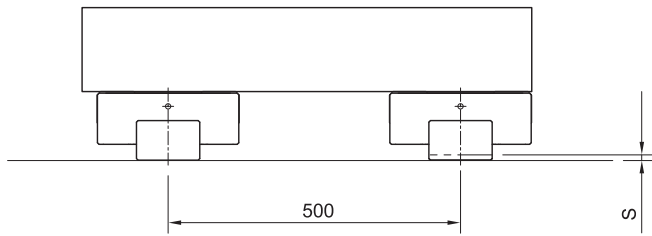

(Unit : mm)

Model size	K1	K2	K3
15	0.13	0.085	-
20	0.13	0.085	0.05
25	0.13	0.085	0.07
30	0.17	0.11	0.09
35	0.21	0.15	0.12
45	0.25	0.17	0.14
55	0.3	0.21	0.17
65	0.35	0.25	0.2

㉓ Linear Rail System

㉔ Ball Screw

㉕ Support Unit

㉖ Linear Ball Bush

㉗ Cross Roller Guide

㉘ Robot Carrer Guide

Memo

Linear Rail System

SBG Standard Linear Rail System

SH Bellows

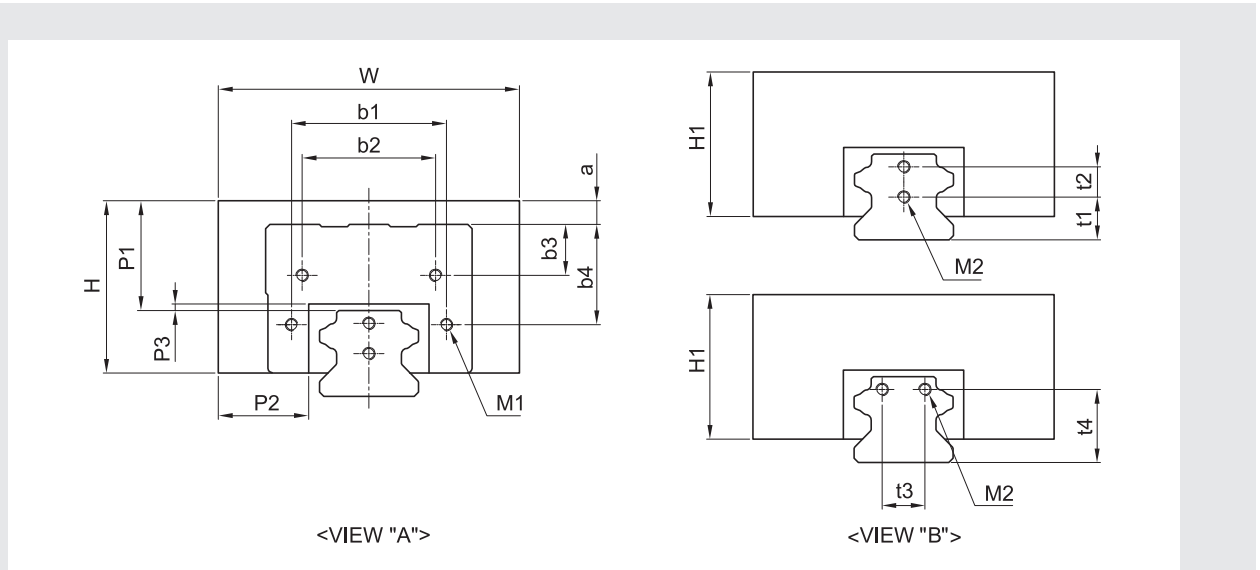

Model number	Applicable type	W	H	H1	P1	P2	P3	a						b1	b2
								SBG		SBS					
								FL	SL	SL	FV	SV	HL		
SH15	SBG(S)15	55	27	27	15	17	1.5	6	2	6	6	6	-	-	26
SH20	SBG(S)20	66	32	32	18	19	3	5.5	5.5	7.5	7.5	7.5	-	33	24
SH25	SBG(S)25	78	38	38	22.7	23.5	3.7	8.5	4.5	11.5	11.5	11.5	8.5	40.8	21
SH30	SBG(S)30	84	42	42	24	24	4	7	4	7	-	-	-	53	37
SH35	SBG(S)35	88	43	43	21.5	22	4	2.5	-4.5	2.5	-	-	-	62	62
SH45	SBG(S)45	100	50	55	22	22.5	4	0	-10	0	-	-	-	76	57
SH55	SBG55	108	55.5	55.5	23.5	22.5	4.5	-1.5	-11.5	-	-	-	-	67	62
SH65	SBG65	132	71.5	71.5	30.5	28.5	6	-1	-1	-	-	-	-	92	84

- * Same dimension for SBG, SBS, SPG and SPS
- * The dimension in column "a, b3 and b4" are common for FL=FLL, SL=SLL and HL=HLL.
- * If SH bellows are applying, rail end mounting holes are necessary.
- * When you select SH bellows, please select the side grease fitting for lubrication.
- * Please contact SBC for more information.

Linear Rail System

SBG Standard Linear Rail System

㉓ Linear Rail System

㉔ Ball Screw

㉕ Support Unit

㉖ Linear Ball Bush

㉗ Cross Roller Guide

㉘ Robot Carrer Guide

Memo

[Calculation of bellows length]

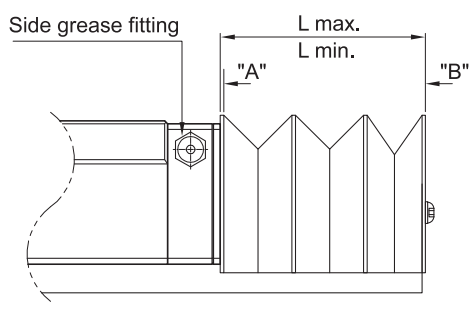

$$A = \frac{L_{max}}{L_{min}}$$

- L_{max} : Extended length (mm)
- L_{min} : Collapsed length (mm)

	L _{min}	L _{max}
*SBG 15	Stroke ÷ 4	L _{min} + Stroke
*SBG 20	Stroke ÷ 5	
*SBG 25-65	Stroke ÷ 6	

* Same dimensions for SBG, SBS, SPG, SPS

(Unit : mm)

b3						b4						t1	t2	t3	t4	M x Bolt length			A (Extended ratio)	
SBG		SBS				SBG		SBS								M1(Block) M2(Block) M3(Rail)				
FL	SL	SL	FV	SV	HL	FL	SL	SL	FV	SV	HL									
10	14	10	10	10	-	-	-	-	-	-	-	9	-	-	-	-	M2X8	M4X8	5	
7	7	5	5	5	-	14	14	12	12	12	-	6.5	8	-	-	-	M2X8	M2X8	M3X6	6
8.2	12.2	5.2	5.2	5.2	8.2	20.2	24.2	17.2	17.2	17.2	20.2	10	8	-	-	-	M2X8	M2X8	M3X6	7
3.5	6.5	3.5	-	-	-	32.5	35.5	32.5	-	-	-	11	10	-	-	-	M3X8	M3X8	M4X8	
3.5	10.5	3.5	-	-	-	37.5	44.5	37.5	-	-	-	-	-	14	14	-	M3X8	M3X8	M4X8	
5	15	5	-	-	-	31.5	41.5	31.5	-	-	-	-	-	20	29	-	M5X10	M3X8	M5X10	
6.3	16.3	-	-	-	-	36.5	46.5	-	-	-	-	-	-	26	35	-	M5X10	M3X8	M5X10	
6	6	-	-	-	-	67.5	67.5	-	-	-	-	-	-	32	42	-	M3X8	M3X8	M6X12	

Ordering example : **SH25 - 70 / 420**

- ①
- ②
- ③

- ① Model number
- ② Collapsed length (mm)
- ③ Extended length (mm)

Linear Rail System

SBG Standard Linear Rail System

RC Cap

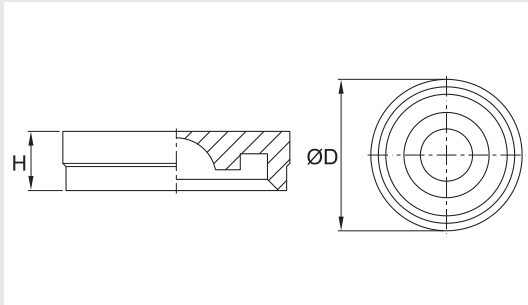

(Unit : mm)

Model	D±0.1	H±0.1
RC 15	7.6	1.3
RC 20	9.6	3.5
RC 25	11.1	2.8
*RC 30	14.2	3.7
RC 45	20.2	4.7
RC 55	23.2	6
RC 65	26.2	6

- RC 30 is used for SBG 30, 35 rail.
- SBI, SBG type use same RC cap.

ST Tape

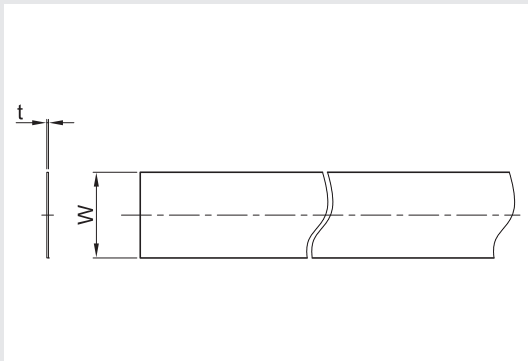

(Unit : mm)

Model	W	t
ST 15	8.3	0.1
ST 20	11	0.1
ST 25	13	0.1
ST 30	17	0.1
ST 35	21	0.1
ST 45	30	0.1
ST 55	34	0.1
ST 65	40	0.1

Ordering example : **ST15 - 1000L**

① ②

- ① Model number
- ② Length

- Equivalent rail is used for SBG, SBS, SPG, SPS

Linear Rail System

SBG Standard Linear Rail System

Seal and MF container

[Method and overall length with each seal]

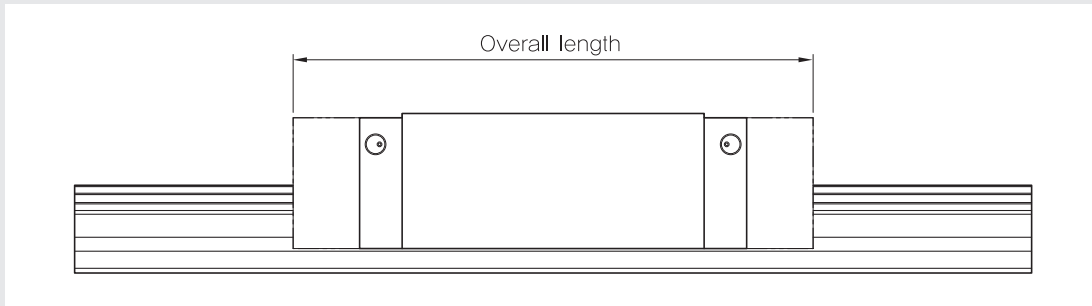

• E : End seal S : Scraper F : MF (Self lubricant) (Unit : mm)

Additional seal	Standard	DD	ZZ	KK	MF	MFDD	MFZZ	MFKK
Indication of seal	E	E+E	E+S	E+E+S	F+E	F+E+E	F+E+S	F+E+E+S
Overall length with seal	15	60.8	66.8	65.2	71.2	-	-	-
	15V	44.9	50.9	49.3	55.3	-	-	-
	20	77.2	83.6	82.6	89	93.2	99.6	105
	20L	93.2	99.6	98.6	105	109.2	115.6	121
	20V	54.2	60.6	59.6	66	70.2	76.6	82
	25	86.9	93.3	92.7	99.1	102.9	109.3	108.7
	25L	106.4	112.8	112.2	118.6	122.4	128.8	128.2
	25V	62.6	69	68.4	74.8	78.6	85	84.4
	30	100	104.6	105.4	110	116	120.6	121.4
	30L	122.5	127.1	127.9	132.5	138.5	143.1	143.9
	35	112.6	117.2	117.4	122	128.6	133.2	133.4
	35L	138.1	142.7	142.9	147.5	154.1	158.7	158.9
	45	140.3	145.1	145.2	150	156.3	161.1	161.2
	45L	172.3	177.1	177.2	182	188.3	193.1	193.2
55	166.8	172.8	170.4	176.4	-	-	-	
55L	204.8	210.8	208.4	214.4	-	-	-	
65	195.2	201.2	202.4	208.4	-	-	-	
65L	255.2	261.2	262.4	268.4	-	-	-	

- Bottom seal of SBG(S) type is integrated with bottom retainer. (Except SBG, SBS15)
- If block is assembled with MF container, the grease fitting is not supplied. If you would like to feed the grease to the block, please order side grease fitting type.

Linear Rail System

SBG Standard Linear Rail System

[Dimension of MF container]

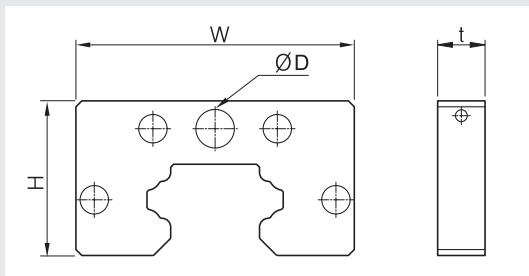

(Unit : mm)

Reference	Model	W	t	H	D
MF	20	43	8	24	6.5
	25	47	8	26.1	6.5
	30	59	8	34.5	6.5
	35	68	8	40	6.5
	45	84	8	49	8.5

※ Container is available for SBG(S), SPG(S) 20~45

[Seal resistance]

For the maximum value of seal resistance of SBG standard type per block, in which grease is not applied.

※ Scraper has no resistance because it is not contacting rail.

(Unit : N)

Model	End seal	MF
SBG 15	1.96	-
SBG 20	2.58	1.61
SBG 25	3.92	4.21
SBG 30	7.84	6.37
SBG 35	11.76	7.06
SBG 45	19.6	7.35
SBG 55	19.6	-
SBG 65	34.3	-

Linear Rail System

SBG Standard Linear Rail System

HT high temperature end plate

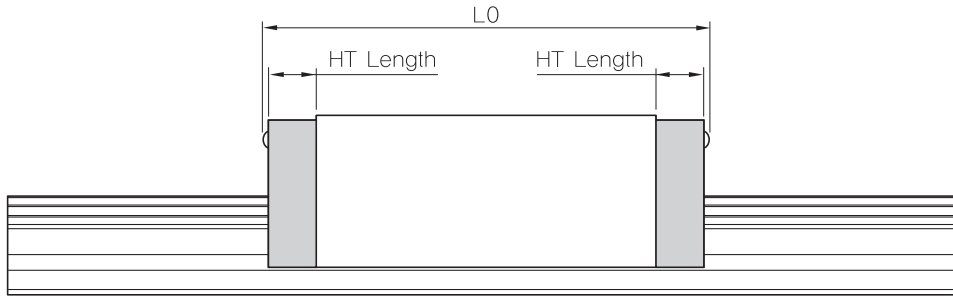

(Unit : mm)

Reference	HT Length	Overall length					
		Applied model	LO	Applied model	LO	Applied model	LO
HT 15	8	SBG(S) 15	54.8	-	-	SBS 15V	38.9
HT 20	10	SBG(S) 20	70.8	SBG(S) 20L	86.8	SBS 20V	47.8
HT 25	10.5	SBG(S) 25	83.9	SBG(S) 25L	103.4	SBS 25V	59.6
HT 30	11.5	SBG(S) 30	98.4	SBG(S) 30L	120.9	-	-
HT 35	12	SBG(S) 35	110.4	SBG(S) 35L	135.9	-	-
HT 45	16	SBG(S) 45	138	SBG(S) 45L	170	-	-
HT 55	18	SBG(S) 55	162	SBG(S) 55L	200	-	-
HT 65	18	SBG(S) 65	194	SBG(S) 65L	254	-	-

Ordering example : **SBG25FL - HT - 2 - K1 - 800 - N**

①

②

③

④

⑤

⑥

① Model

② High temperature end plate

③ Block quantity

④ Preload

⑤ Rail length

⑥ Accuracy

※ All plastic components are replace with steel or aluminum in the High Temperature Blocks.

※ Side grease fitting is not available for high temperature end plates

Grease and nipple specification

[Grease]

SBG uses two types of grease according to working conditions.
For details, please see the technical data for grease.

㉓ Linear Rail System

㉔ Ball Screw

㉕ Support Unit

㉖ Linear Ball Bush

㉗ Cross Roller Guide

㉘ Robot Carrer Guide

Memo

Linear Rail System

SBG Standard Linear Rail System

(1) Standard grease fitting (Front grease fitting)

(Unit : mm)

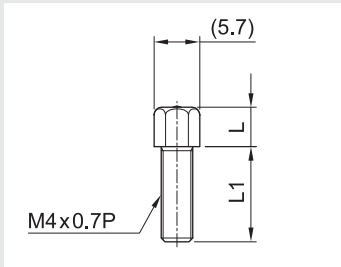

Specification		M4x0.7P		
Applied model	Grease fitting model	Symbol	L	L1
SBG(S) 15	1N	None	7	5.5
	1D	DD, ZZ	5	9
	1Z	KK	5	11

(Unit : mm)

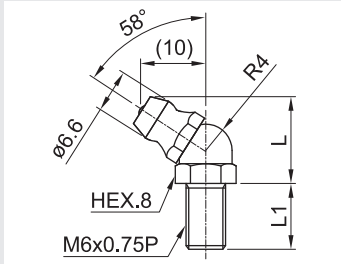

Specification		M6x0.75P, Asia type		
Applied model	Grease fitting model	Symbol	L	L1
SBG(S) 20~35	GA2N	None	15	9.5
	GA2D	DD, ZZ	15	12.5
	GA2Z	KK	15	15.5

(Unit : mm)

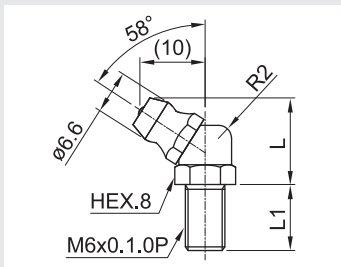

Specification		M6x1.0P, Europe type		
Applied model	Grease fitting model	Symbol	L	L1
SBG(S) 20~35	GE2N	None	15	9.5
	GE2D	DD, ZZ	15	12.5
	GE2Z	KK	15	15.5

(Unit : mm)

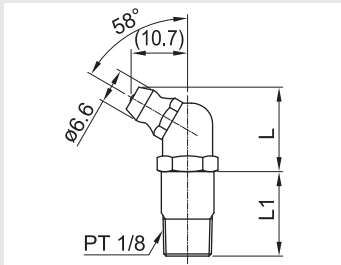

Specification		PT 1/8		
Applied model	Grease fitting model	Symbol	L	L1
SBG(S) 45~65	4N	None	17	12
	4D	DD, KK, ZZ	17	16

Linear Rail System

SBG Standard Linear Rail System

㉓ Linear Rail System

㉔ Ball Screw

㉕ Support Unit

㉖ Linear Ball Bush

㉗ Cross Roller Guide

㉘ Robot Carrer Guide

Memo

(2) Side grease fitting

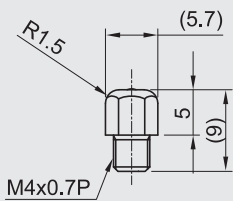

Specification	M4x0.7P
Applied model	SBG(S) 15
Grease fitting model	S1N

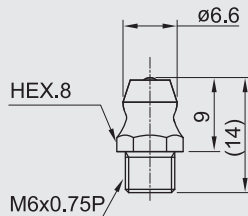

Specification	M6x0.75P
Applied model	SBG(S) 20, 25, 30, 35
Grease fitting model	S3N

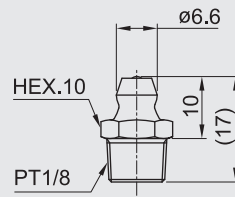

Specification	PT1/8
Applied model	SBG(S) 45, 55, 65
Grease fitting model	S4N

(3) FS nipple connector for side grease fitting (FL, FLL flange type only) *Please see the page @/36 for assembling the nipple connector.

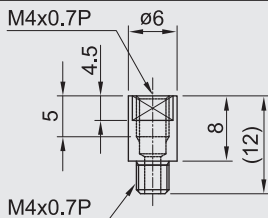

Specification	M4x0.7P
Applied model	SBG(S) 15
Grease fitting model	S1C

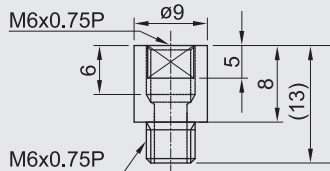

Specification	M6x0.75P
Applied model	SBG(S) 20, 25, 30, 35
Grease fitting model	S4C

* For size 30~35, two pieces of FS nipple connector are applied.

(4) Copper pipe

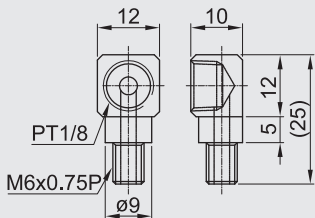

Input size	PT1/8
Output size	M6x0.75P
Applied model	SBG(S) 20
Grease fitting model	SB02

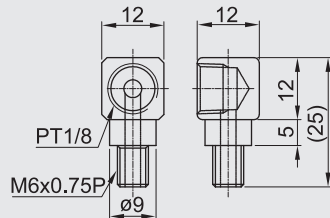

Input size	PT1/8
Output size	M6x0.75P
Applied model	SBG(S) 25, 30, 35
Grease fitting model	SB01

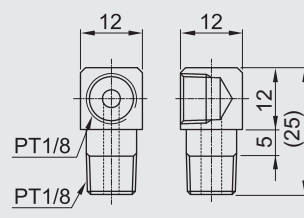

Input size	PT1/8
Output size	PT1/8
Applied model	SBG(S) 45, 55, 65
Grease fitting model	SB21

Linear Rail System

SBG Standard Linear Rail System

Ordering example

SBG20 **FL** - **N** - **MF** - **ZZ** - **K1**
 [1] [2] [3] [4] [5] [6]

[1] Model : SBG, SBS, SPG, SPS

[2] Block type : FL, FLL, SL, SLL, HL, HLL, FV, SV

[3] Position of grease fitting : None (front), N (side)

[4] Container : No symbol (standard), DF (high dust protection), MF (self lubricant)

[5] Seal : No symbol (standard), DD, ZZ, KK

[6] Preload : K1, K2, K3

※ "K3" Preload is not available for SBG, SBS 15 type

[Ordering example for rail]

SBG20 - **1000L** - **B**
 [1] [2] [3]

[1] Model : SBG

[2] Rail length

[3] Bottom mounting : No symbol (standard), B (bottom mounting rail)

※ If only rail is ordered, N grade is available.

※ An order for rail only, please mark it as SBG since same rail is used for SBG, SBS, SPG, SPS

Linear Rail System

SBG Standard Linear Rail System

[Ordering for assembled rail and block]

SBG20 FL - N - MF - ZZ - 2 - K1 - 800 - N - R - B - II
 [1] [2] [3] [4] [5] [6] [7] [8] [9] [10] [11] [12]

- [1] Model : SBG, SBS, SPG, SPS
- [2] Block type : FL, FLL, FV, SL, SLL, SV, HL, HLL
- [3] Position of grease fitting : None (front), N (side)
- [4] Container : No symbol (standard), DF (high dust protection), MF (self lubricant)
- [5] Seal : No symbol (standard), DD, ZZ, KK
- [6] Block quantity on rail
- [7] Preload : K1, K2, K3
- [8] Rail length
- [9] Accuracy : N, H, P
- [10] Surface treatment
- [11] (B) Bottom mounting rail : No symbol (standard)
- [12] Rail : number of rails per axis, 1=I, 2=II... 4=IV etc.

- ※ We recommend block and rail assembled to be ordered where high-precision and high-rigidity are required.
- ※ For surface treatment, please mark according to each surface treatment symbol.
- ※ If special G dimension is required, please mark when you place an order.
- ※ Please contact SBC for high temperature order.
- ※ "K3" Preload is not available for SBG, SBS 15 type

㉓ Linear Rail System

㉔ Ball Screw

㉕ Support Unit

㉖ Linear Ball Bush

㉗ Cross Roller Guide

㉘ Robot Carrier Guide

Memo

Linear Rail System

SBG Standard Linear Rail System

Standard and Max. Length of SBG rail

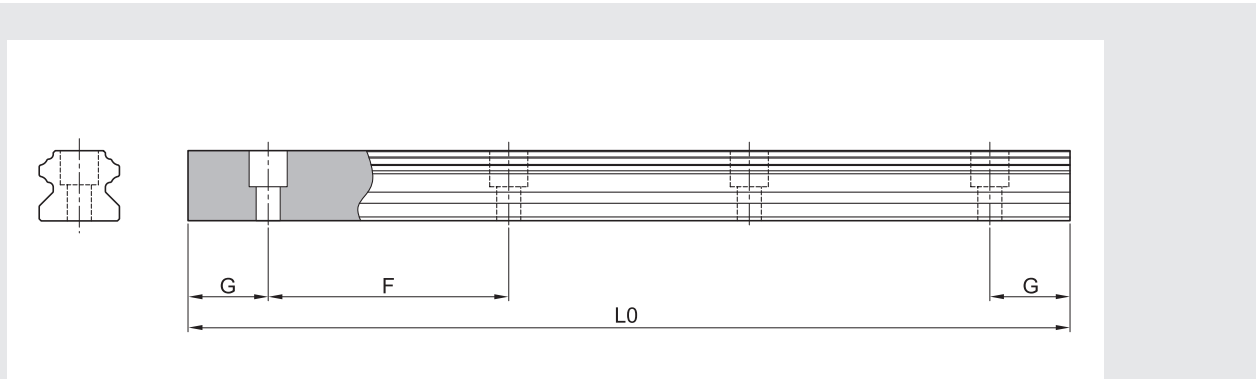

(Unit : mm)

Model number	SBG15	SBG20	SBG25	SBG30	SBG35	SBG45	SBG55	SBG65
Standard length	160	220	220	280	280	570	780	1270
	220	280	280	440	440	885	900	1570
	280	240	340	600	600	1095	1020	2020
	340	460	460	760	760	1200	1140	2470
	460	640	640	1000	1000	1410	1260	2620
	640	820	820	1240	1240	1620	1380	2920
	820	1000	1000	1480	1480	1830	1500	3070
	1000	1240	1240	1640	1640	2040	1620	-
	1240	1480	1480	1800	1800	2250	1740	-
	1480	1600	1600	2040	2040	2460	1860	-
	1600	1840	1840	2200	2200	2985	1980	-
	1960	2080	2080	2520	2520	3510	2220	-
	2200	2200	2200	2840	2840	-	2580	-
	2500	2500	2500	3000	3000	-	2940	-
	2860	2960	2980	3480	3480	-	3540	-
	-	3520	3520	-	-	-	-	-
-	4000	4000	-	-	-	-	-	
F	60	60	60	80	80	105	120	150
G	20	20	20	20	20	22.5	30	35
L0(Max length)	3,000	4,000	4,000	4,000	4,000	4,000	4,000	4,000

* The rail for SBG(S), SPG(S) is identical.

* If the maximum length exceeds this size, butt joints can be supplied.

* For more information about butt jointing, please refer to the page of safety design.

* If the G is not standard, please indicate it in the order sheet.

Linear Rail System

SBG Standard Linear Rail System

Bottom mounting rail (SBG-B type)

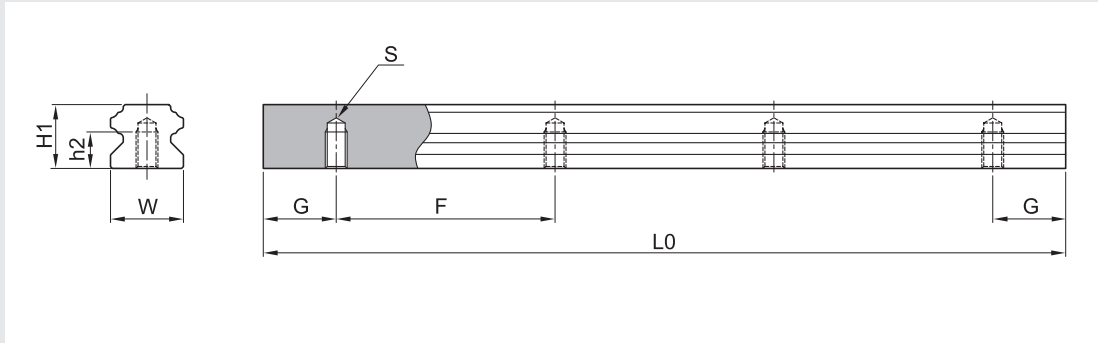

(Unit : mm)

Model number	W1	H1	S	h2	G	F	L0 (Max length)	Weight (kg/m)
SBG 15-B	15	15	M5x0.8	8	20	60	3,000	1.53
SBG 20-B	20	17.5	M6	10	20	60	4,000	2.28
SBG 25-B	23	21.8	M6	12	20	60	4,000	3.21
SBG 30-B	28	25	M8	15	20	80	4,000	4.58
SBG 35-B	34	29	M8	17	20	80	4,000	6.62
SBG 45-B	45	38	M12	24	22.5	105	4,000	11.43

* The rail for SBG(S), SPG(S) is identical

* If the maximum length exceeds this size, please contact SBC.

㉓ Linear Rail System

㉔ Ball Screw

㉕ Support Unit

㉖ Linear Ball Bush

㉗ Cross Roller Guide

㉘ Robot Carrer Guide

Memo

Linear Rail System

SBG Standard Linear Rail System

SBG-FL/FLL

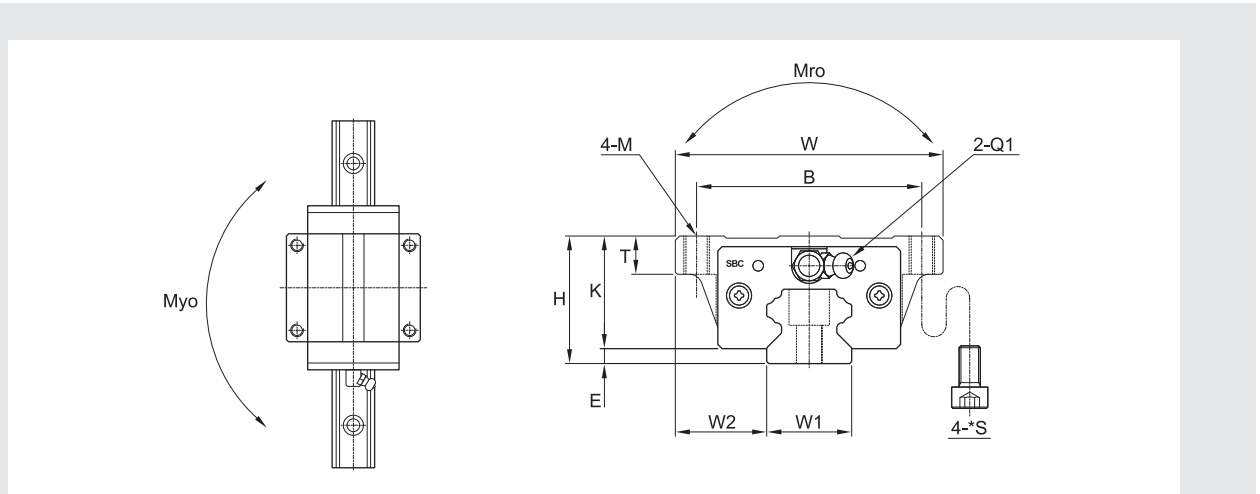

Model	Mounting dimension				Block dimensions												
	H	W	L	E	Mounting tap hole				L1	T	K	Grease fitting					
					B	J	M	*S				T1	N1	T2	N2	Q1	*Q2
SBG15 FL	24	47	60.8	3	38	30	M5	M4	38.8	7.2	21	4	5	5.5	4.5	M4x0.7	Ø3.5
SBG20 FL	30	63	77.2	3.5	53	40	M6	M5	50.8	9	26.5	7	9.8	12	5	M6x0.75	Ø5.5
SBG20 FLL	30	63	93.2	3.5	53	40	M6	M5	66.8	9	26.5	7	9.8	12	5	M6x0.75	Ø5.5
SBG25 FL	36	70	86.9	6.5	57	45	M8	M6	59.5	10	29.5	8.2	9.8	12	5.5	M6x0.75	Ø5.5
SBG25 FLL	36	70	106.4	6.5	57	45	M8	M6	79	10	29.5	8.2	9.8	12	5.5	M6x0.75	Ø5.5
SBG30 FL	42	90	100	7	72	52	M10	M8	70.4	12	35	8.5	10.7	12	5.5	M6x0.75	Ø5.5
SBG30 FLL	42	90	122.5	7	72	52	M10	M8	92.9	12	35	8.5	10.7	12	5.5	M6x0.75	Ø5.5
SBG35 FL	48	100	112.6	7.5	82	62	M10	M8	80.4	13	40.5	8	10.7	12	6	M6x0.75	Ø5.5
SBG35 FLL	48	100	138.1	7.5	82	62	M10	M8	105.9	13	40.5	8	10.7	12	6	M6x0.75	Ø5.5
SBG45 FL	60	120	140.4	10	100	80	M12	M10	98	15	50	10	11	16.5	8	PT1/8	Ø8.5
SBG45 FLL	60	120	172.4	10	100	80	M12	M10	130	15	50	10	11	16.5	8	PT1/8	Ø8.5
SBG55 FL	70	140	164.8	13	116	95	M14	M12	118	17	57	12	11	16.5	10	PT1/8	Ø8.5
SBG55 FLL	70	140	202.8	13	116	95	M14	M12	156	17	57	12	11	16.5	10	PT1/8	Ø8.5
SBG65 FL	90	170	195.2	17.5	142	110	M16	M14	147	23	72.5	15	11	16.5	10	PT1/8	Ø8.5
SBG65 FLL	90	170	255.2	17.5	142	110	M16	M14	207	23	72.5	15	11	16.5	10	PT1/8	Ø8.5

① C (Basic dynamic load rating), Co (Basic static load rating)

② *S: Bolt size for bottom mounting type of block.

Linear Rail System

SBG Standard Linear Rail System

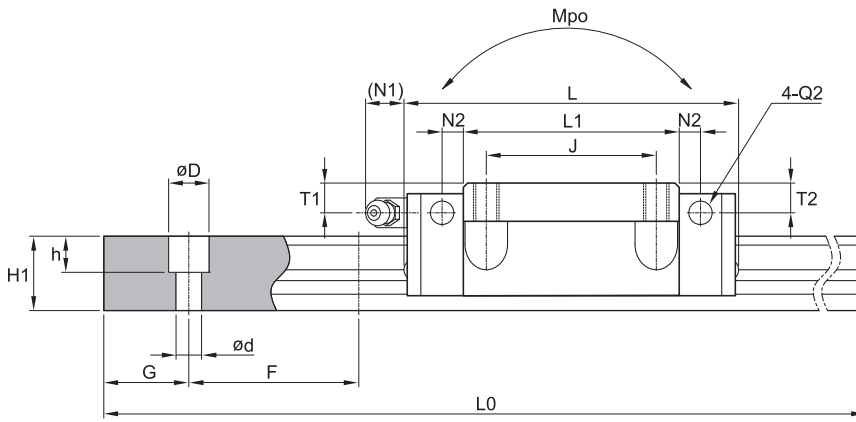

(Unit : mm)

Rail dimension									Basic load rating [kN]		Permissible static moment [kN · m]			Mass	
W1	W2	H1	F	Bolt hole			G	Max length of rail L0	C	Co	Mro	Mpo	Myo	Block [kg]	Rail [kg/m]
				d	D	h									
15	16	15	60	4.5	7.5	5.3	20	3000	8.33	13.4	0.07	0.05	0.05	0.18	1.45
20	21.5	17.5	60	6	9.5	8.5	20	4000	14.2	25	0.22	0.18	0.18	0.42	2.2
20	21.5	17.5	60	6	9.5	8.5	20	4000	16.9	36.5	0.28	0.31	0.31	0.54	2.2
23	23.5	21.8	60	7	11	9	20	4000	20.9	39.2	0.35	0.31	0.3	0.62	3.1
23	23.5	21.8	60	7	11	9	20	4000	24.6	48	0.43	0.49	0.48	0.78	3.1
28	31	25	80	9	14	12	20	4000	29.2	53.8	0.59	0.49	0.48	1.1	4.45
28	31	25	80	9	14	12	20	4000	35.3	67.9	0.74	0.79	0.78	1.44	4.45
34	33	29	80	9	14	12	20	4000	38.8	68.6	0.94	0.74	0.72	1.57	6.4
34	33	29	80	9	14	12	20	4000	46	90.4	1.24	1.3	1.28	2.14	6.4
45	37.5	38	105	14	20	17	22.5	4000	61.6	110.6	1.98	1.56	1.54	2.96	11.25
45	37.5	38	105	14	20	17	22.5	4000	75.5	138.5	2.45	2.33	2.3	3.75	11.25
53	43.5	45	120	16	23	20	30	4000	91.2	156.9	3.37	2.69	2.65	4.49	15.25
53	43.5	45	120	16	23	20	30	4000	111.8	196.6	4.19	4.05	3.97	5.68	15.25
63	53.5	58.5	150	18	26	22	35	4000	147.9	240.1	6.17	4.85	4.75	8.7	23.9
63	53.5	58.5	150	18	26	22	35	4000	189.1	320.4	8.18	8.34	8.14	9.5	23.9

③ *Q2: The hole of side grease nipple is not made to prevent a foreign substance from going into inside.
When you order the side grease nipple, we build it by ourselves.

Linear Rail System

SBG Standard Linear Rail System

SBG-SL/SLL

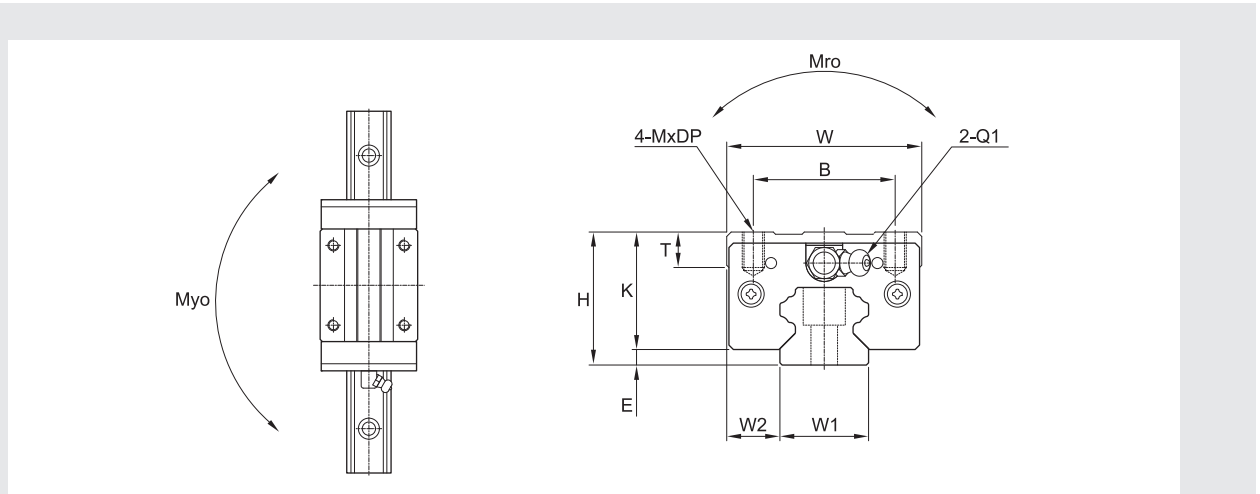

Model	Mounting dimension				Block dimensions												
	H	W	L	E	Mounting tap hole				L1	T	K	Grease fitting					
					B	J	M	DP				T1	N1	T2	N2	Q1	*Q2
SBG15 SL	28	34	60.8	3	26	26	M4	5	38.8	8	25	8	5.5	8.5	4.5	M4x0.7	Ø3.5
SBG20 SL	30	44	77.2	3.5	32	36	M5	8	50.8	8	26.5	7	12	7	5	M6x0.75	Ø5.5
SBG20 SLL	30	44	93.2	3.5	32	50	M5	8	66.8	8	26.5	7	12	7	5	M6x0.75	Ø5.5
SBG25 SL	40	48	86.9	6.5	35	35	M6	8	59.5	12	33.5	12.2	12	12.1	5.5	M6x0.75	Ø5.5
SBG25 SLL	40	48	106.4	6.5	35	50	M6	8	79	12	33.5	12.2	12	12.1	5.5	M6x0.75	Ø5.5
SBG30 SL	45	60	100	7	40	40	M8	10	70.4	12	38	11.5	12	11.5	5.5	M6x0.75	Ø5.5
SBG30 SLL	45	60	122.5	7	40	60	M8	10	92.9	12	38	11.5	12	11.5	5.5	M6x0.75	Ø5.5
SBG35 SL	55	70	112.6	7.5	50	50	M8	12	80.4	15	47.5	15	12	15	6	M6x0.75	Ø5.5
SBG35 SLL	55	70	138.1	7.5	50	72	M8	12	105.9	15	47.5	15	12	15	6	M6x0.75	Ø5.5
SBG45 SL	70	86	140.4	10	60	60	M10	13	98	15	60	15	16.5	20	8	PT1/8	Ø8.5
SBG45 SLL	70	86	172.4	10	60	80	M10	13	130	15	60	15	16.5	20	8	PT1/8	Ø8.5
SBG55 SL	80	100	164.8	13	75	75	M12	18	118	18	67	18	16.5	20.5	10	PT1/8	Ø8.5
SBG55 SLL	80	100	202.8	13	75	95	M12	18	156	18	67	18	16.5	20.5	10	PT1/8	Ø8.5
SBG65 SL	90	126	195.2	17.5	76	70	M16	20	147	23	72.5	23	16.5	12	10	PT1/8	Ø8.5
SBG65 SLL	90	126	255.2	17.5	76	120	M16	20	207	23	72.5	23	16.5	12	10	PT1/8	Ø8.5

① C (Basic dynamic load rating), Co (Basic static load rating)

Linear Rail System

SBG Standard Linear Rail System

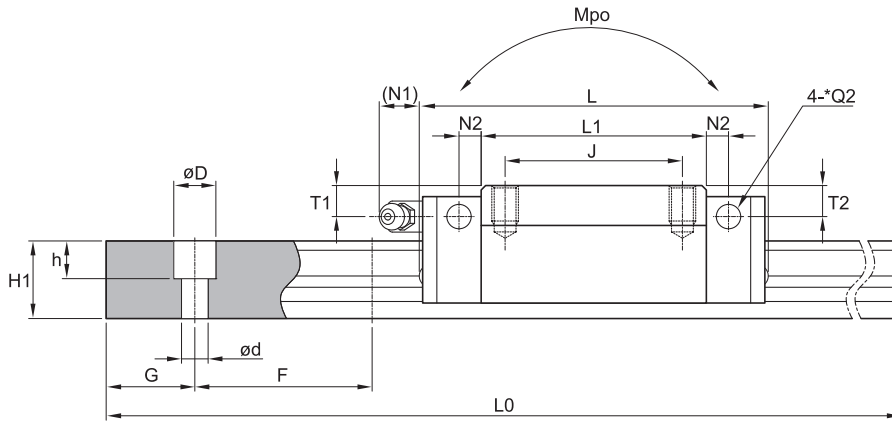

(Unit : mm)

Rail dimension									Basic load rating [kN]		Permissible static moment [kN·m]			Mass	
W1	W2	H1	F	Bolt hole			G	Max length of rail L0	C	Co	Mro	Mpo	Myo	Block [kg]	Rail [kg/m]
				d	D	h									
15	9.5	15	60	4.5	7.5	5.3	20	3000	8.33	13.4	0.07	0.05	0.05	0.2	1.45
20	12	17.5	60	6	9.5	8.5	20	4000	14.2	25	0.22	0.18	0.18	0.33	2.2
20	12	17.5	60	6	9.5	8.5	20	4000	16.9	36.5	0.28	0.31	0.31	0.45	2.2
23	12.5	21.8	60	7	11	9	20	4000	20.9	39.2	0.35	0.31	0.3	0.56	3.1
23	12.5	21.8	60	7	11	9	20	4000	24.6	48	0.43	0.49	0.48	0.73	3.1
28	16	25	80	9	14	12	20	4000	29.2	53.8	0.59	0.49	0.48	0.98	4.45
28	16	25	80	9	14	12	20	4000	35.3	67.9	0.74	0.79	0.78	1.28	4.45
34	18	29	80	9	14	12	20	4000	38.8	68.6	0.94	0.74	0.72	1.63	6.4
34	18	29	80	9	14	12	20	4000	46	90.4	1.24	1.3	1.28	2.12	6.4
45	20.5	38	105	14	20	17	22.5	4000	61.6	110.6	1.98	1.56	1.54	2.96	11.25
45	20.5	38	105	14	20	17	22.5	4000	75.5	138.5	2.45	2.33	2.3	3.75	11.25
53	23.5	45	120	16	23	20	30	4000	91.2	156.9	3.37	2.69	2.65	4.52	15.25
53	23.5	45	120	16	23	20	30	4000	111.8	196.6	4.19	4.05	3.97	5.68	15.25
63	31.5	58.5	150	18	26	22	35	4000	147.9	240.1	6.17	4.85	4.75	7.43	23.9
63	31.5	58.5	150	18	26	22	35	4000	189.1	320.4	8.18	8.34	8.14	12.05	23.9

② *Q2: The hole of side grease nipple is not made to prevent a foreign substance from going into inside. When you order the side grease nipple, we build it by ourselves.

Linear Rail System

SBG Standard Linear Rail System

SBS-SL, HL/SLL, HLL

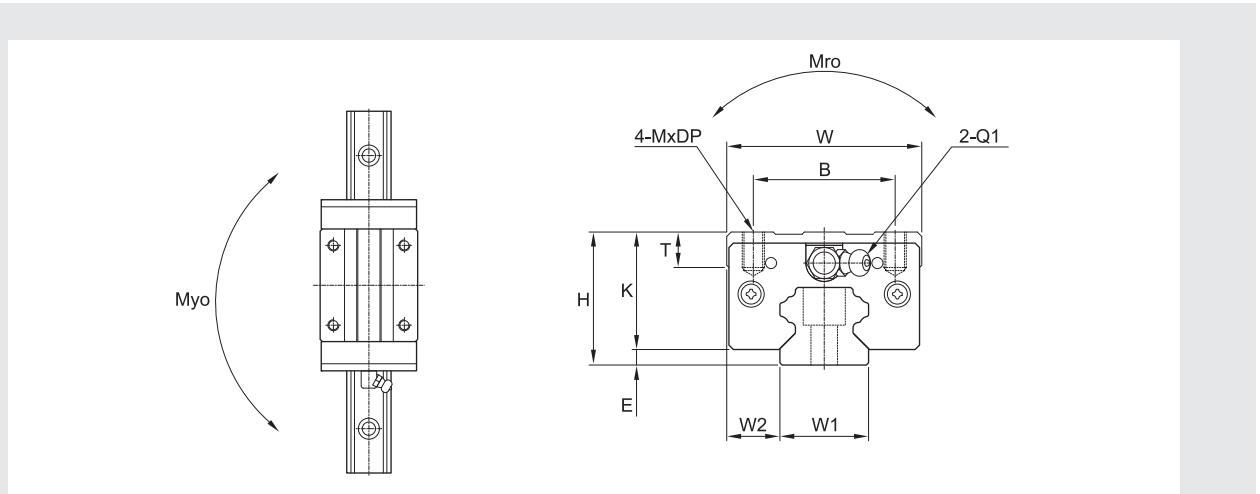

Model	Mounting dimension				Block dimensions												
	H	W	L	E	Mounting tap hole				L1	T	K	Grease fitting					
					B	J	M	DP				T1	N1	T2	N2	Q1	*Q2
SBS15 SL	24	34	60.8	3	26	26	M4	5	38.8	6	21	4	5.5	4.5	4.5	M4x0.7	Ø3.5
SBS20 SL	28	44	77.2	3.5	32	32	M5	7	50.8	7.5	24.5	5	12	5	5	M6x0.75	Ø5.5
SBS20 SLL	28	44	93.2	3.5	32	50	M5	7	66.8	7.5	24.5	5	12	5	5	M6x0.75	Ø5.5
SBS25 SL	33	48	86.9	6.5	35	35	M6	6	59.5	8	26.5	5.2	12	5.1	5.5	M6x0.75	Ø5.5
SBS25 SLL	33	48	106.4	6.5	35	50	M6	6	79	8	26.5	5.2	12	5.1	5.5	M6x0.75	Ø5.5
SBS25 HL	36	48	86.9	6.5	35	35	M6	8	59.5	11	29.5	8.2	12	8.1	5.5	M6x0.75	Ø5.5
SBS25 HLL	36	48	106.4	6.5	35	50	M6	8	79	11	29.5	8.2	12	8.1	5.5	M6x0.75	Ø5.5
SBS30 SL	42	60	100	7	40	40	M8	10	70.4	12	35	8.5	12	8.5	5.5	M6x0.75	Ø5.5
SBS30 SLL	42	60	122.5	7	40	60	M8	10	92.9	12	35	8.5	12	8.5	5.5	M6x0.75	Ø5.5
SBS35 SL	48	70	112.6	7.5	50	50	M8	12	80.4	15	40.5	8	12	8	6	M6x0.75	Ø5.5
SBS35 SLL	48	70	138.1	7.5	50	72	M8	12	105.9	15	40.5	8	12	8	6	M6x0.75	Ø5.5
SBS45 SL	60	86	140.4	10	60	60	M10	10	98	15	50	10	16.5	10	8	PT1/8	Ø8.5
SBS45 SLL	60	86	172.4	10	60	80	M10	10	130	15	50	10	16.5	10	8	PT1/8	Ø8.5

- ① C (Basic dynamic load rating), Co (Basic static load rating)
- ② *Q2: The hole of side grease nipple is not made to prevent a foreign substance from going into inside.
When you order the side grease nipple, we build it by ourselves.

Linear Rail System

SBG Standard Linear Rail System

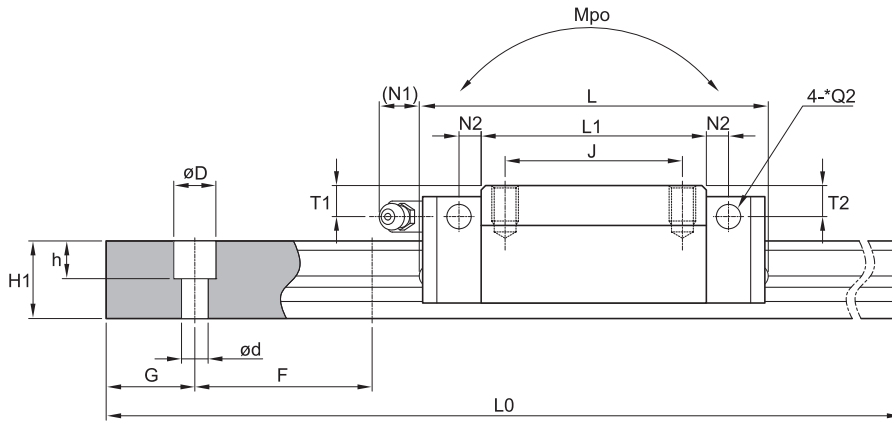

(Unit : mm)

Rail dimension									Basic load rating		Permissible static moment			Mass	
W1	W2	H1	F	Bolt hole			G	Max length of rail L0	C	Co	Mro	Mpo	Myo	Block [kg]	Rail [kg/m]
				d	D	h									
15	9.5	15	60	4.5	7.5	5.3	20	3000	8.33	13.4	0.07	0.05	0.05	0.2	1.45
20	12	17.5	60	6	9.5	8.5	20	4000	14.2	25	0.22	0.18	0.18	0.33	2.2
20	12	17.5	60	6	9.5	8.5	20	4000	16.9	36.5	0.28	0.31	0.31	0.45	2.2
23	12.5	21.8	60	7	11	9	20	4000	20.9	39.2	0.35	0.31	0.3	0.56	3.1
23	12.5	21.8	60	7	11	9	20	4000	24.6	48	0.43	0.49	0.48	0.73	3.1
23	12.5	21.8	60	7	11	9	20	4000	20.9	39.2	0.35	0.31	0.3	0.98	3.1
23	12.5	21.8	60	7	11	9	20	4000	24.6	48	0.43	0.49	0.48	1.28	3.1
28	16	25	80	9	14	12	20	4000	29.2	53.8	0.59	0.49	0.48	0.98	4.45
28	16	25	80	9	14	12	20	4000	35.3	67.9	0.74	0.79	0.78	1.28	4.45
34	18	29	80	9	14	12	20	4000	38.8	68.6	0.94	0.74	0.72	1.63	6.4
34	18	29	80	9	14	12	20	4000	46	90.4	1.24	1.3	1.28	2.12	6.4
45	20.5	38	105	14	20	17	22.5	4000	61.6	110.6	1.98	1.56	1.54	2.96	11.25
45	20.5	38	105	14	20	17	22.5	4000	75.5	138.5	2.45	2.33	2.3	3.75	11.25

① Linear Rail System

② Ball Screw

③ Support Unit

④ Linear Ball Bush

⑤ Cross Roller Guide

⑥ Robot Carrer Guide

Memo

Linear Rail System

SBG Standard Linear Rail System

SBS-FV

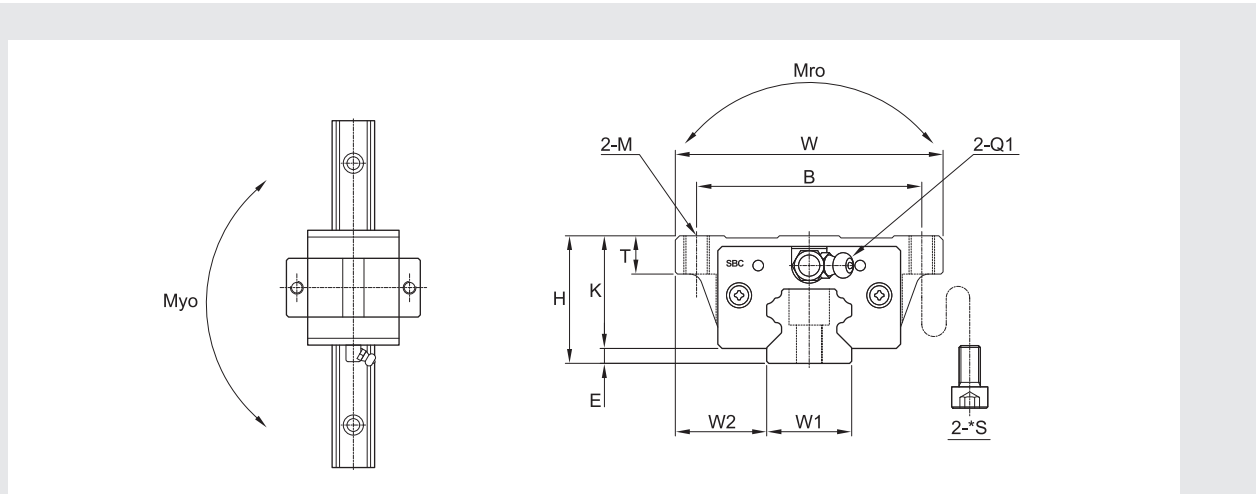

Model	Mounting dimension				Block dimensions											
	H	W	L	E	Mounting tap hole			L1	T	K	Grease fitting					
					B	M	*S				T1	N1	T2	N2	Q1	*Q2
SBS15 FV	24	47	44.9	3	38	M5	M4	22.9	7.2	21	4	5.5	4.5	4.5	M4x0.7	Ø3.5
SBS20 FV	28	63	54.2	3.5	53	M6	M5	27.8	7	24.5	5	12	5	5	M6x0.75	Ø5.5
SBS25 FV	33	70	62.6	6.5	57	M8	M6	35.2	7	26.5	5.2	12	5.1	5.5	M6x0.75	Ø5.5

- ① C (Basic dynamic load rating), Co (Basic static load rating)
- ② *S: Bolt size for bottom mounting type of block.
- ③ *Q2: The hole of side grease nipple is not made to prevent a foreign substance from going into inside.
When you order the side grease nipple, we build it by ourselves.

Linear Rail System

SBG Standard Linear Rail System

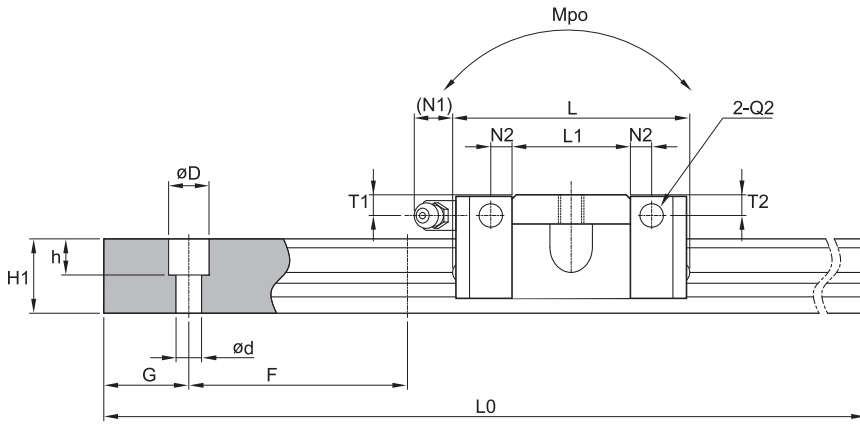

(Unit : mm)

Rail dimension									Basic load rating [kN]		Permissible static moment [kN·m]			Mass	
W1	W2	H1	F	Bolt hole			G	Max length of rail L0	C	Co	Mro	Mpo	Myo	Block [kg]	Rail [kg/m]
				d	D	h									
15	16	15	60	4.5	7.5	5.3	20	3000	4.48	7.23	0.04	0.03	0.03	0.1	1.45
20	21.5	17.5	60	6	9.5	8.5	20	4000	7.65	13.5	0.12	0.1	0.1	0.24	2.2
23	23.5	21.8	60	7	11	9	20	4000	11.29	21.1	0.19	0.17	0.17	0.37	3.1

ⓐ Linear Rail System

ⓑ Ball Screw

ⓒ Support Unit

ⓓ Linear Ball Bush

ⓔ Cross Roller Guide

ⓕ Robot Carrer Guide

Memo

Linear Rail System

SBG Standard Linear Rail System

SBS-SV

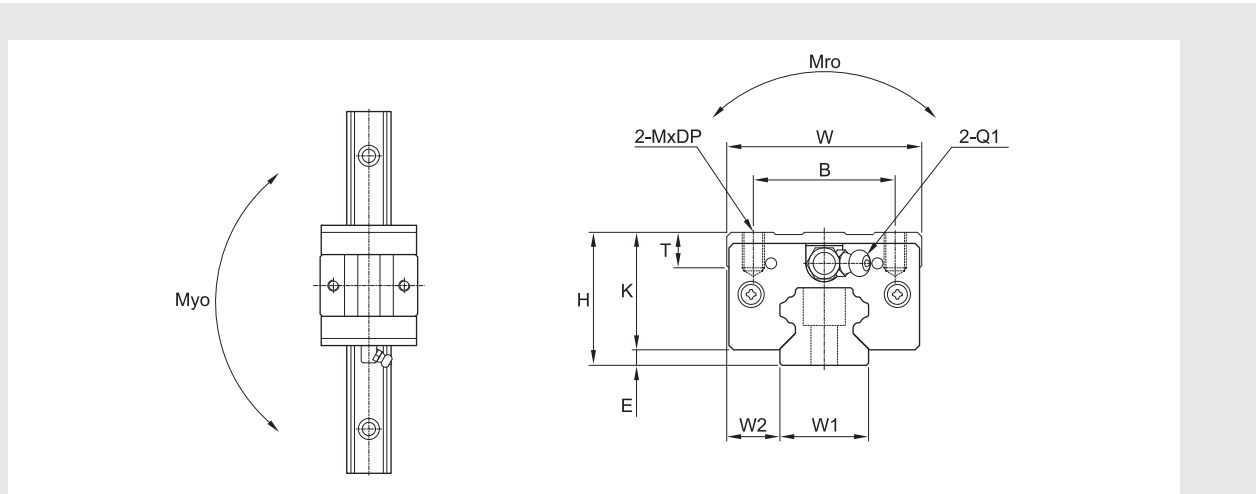

Model	Mounting dimension				Block dimensions											
	H	W	L	E	Mounting tap hole			L1	T	K	Grease fitting					
					B	M	DP				T1	N1	T2	N2	Q1	*Q2
SBS15 SV	24	34	44.9	3	26	M4	5	22.9	6	21	4	5.5	4.5	4.5	M4x0.7	Ø3.5
SBS20 SV	28	44	54.2	3.5	32	M5	7	27.8	7.5	24.5	5	12	5	5	M6x0.75	Ø5.5
SBS25 SV	33	48	62.6	6.5	35	M6	6	35.2	8	26.5	5.2	12	5.1	5.5	M6x0.75	Ø5.5

- ① C (Basic dynamic load rating), Co (Basic static load rating)
- ② *Q2: The hole of side grease nipple is not made to prevent a foreign substance from going into inside.
When you order the side grease nipple, we build it by ourselves.

Linear Rail System

SBG Standard Linear Rail System

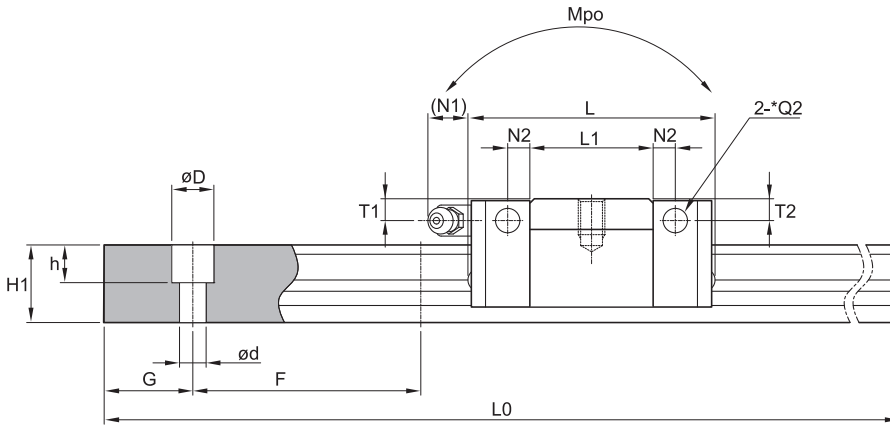

(Unit : mm)

Rail dimension									Basic load rating [kN]		Permissible static moment [kN · m]			Mass	
W1	W2	H1	F	Bolt hole			G	Max length of rail L0	C	Co	Mro	Mpo	Myo	Block [kg]	Rail [kg/m]
				d	D	h									
15	9.5	15	60	4.5	7.5	5.3	20	3000	4.48	7.23	0.04	0.03	0.03	0.1	1.45
20	12	17.5	60	6	9.5	8.5	20	4000	7.65	13.5	0.12	0.1	0.1	0.19	2.2
23	12.5	21.8	60	7	11	9	20	4000	11.29	21.1	0.19	0.17	0.17	0.32	3.1

ⓐ Linear Rail System

ⓑ Ball Screw

ⓒ Support Unit

ⓓ Linear Ball Bush

ⓔ Cross Roller Guide

ⓕ Robot Carrer Guide

Memo

Linear Rail System

SPG / SPS Spacer Linear Rail System

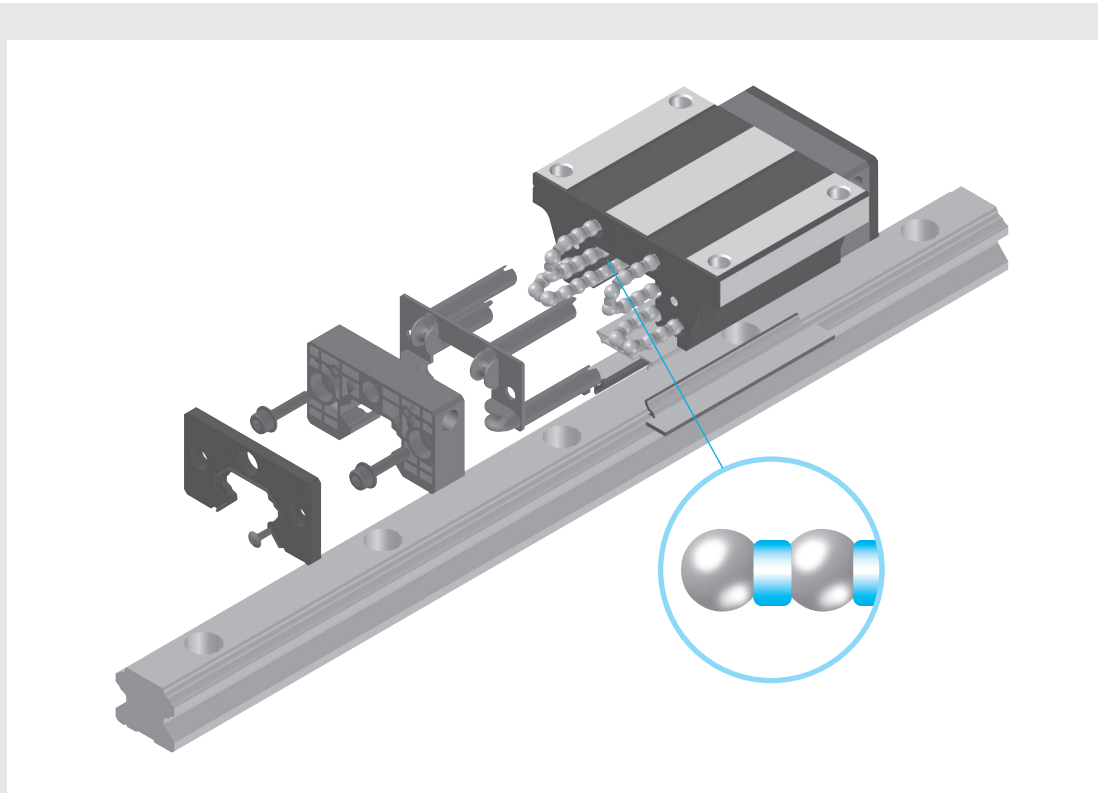

[Design feature]

SPG, SPS type is ball spacer inserted type between balls. This spacer minimizes the noise level by eliminating metal to metal contact and storing grease which provides long term, maintenance free operation.

[Using SBG standard rail]

SPG, SPS type are using SBG standard rail.

[Dimensionally interchangeable with SBG type]

SPG/SPS spacer series blocks are dimensionally interchangeable with SBG/SBS blocks.

Linear Rail System

SPG / SPS Spacer Linear Rail System

㉓ Linear Rail System

㉔ Ball Screw

㉕ Support Unit

㉖ Linear Ball Bush

㉗ Cross Roller Guide

㉘ Robot Carrer Guide

Memo

[Noise level test for SBG35 and SPG35]

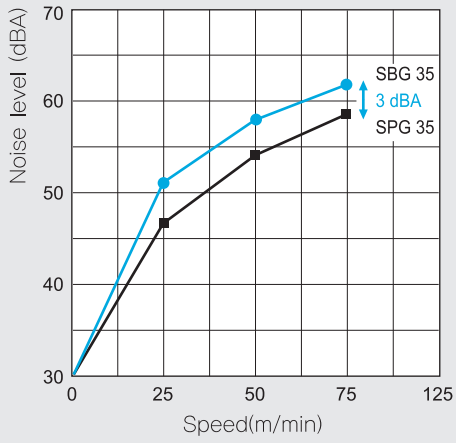

(Comparison of noise level)

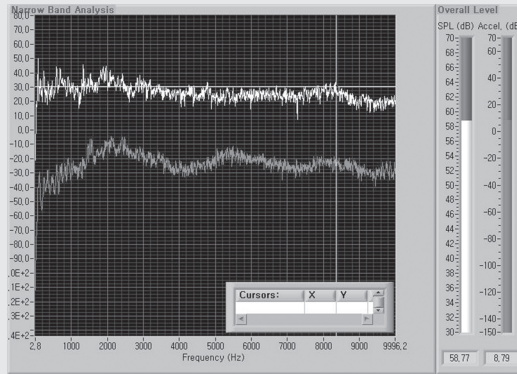

(SPG35 1.3m/sec)

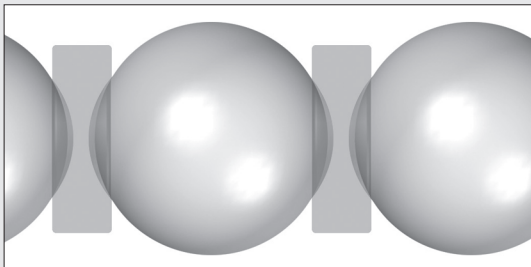

[Grease retention]

The spacers provide grease storage areas providing long term, maintenance free operation.

[Ordering example]

Ordering example for SPG/SPS type are identical with SBG type ordering. Therefore, please see the ordering example for SBG type.

Linear Rail System

SPG / SPS Spacer Linear Rail System

SPG-FL/FLL

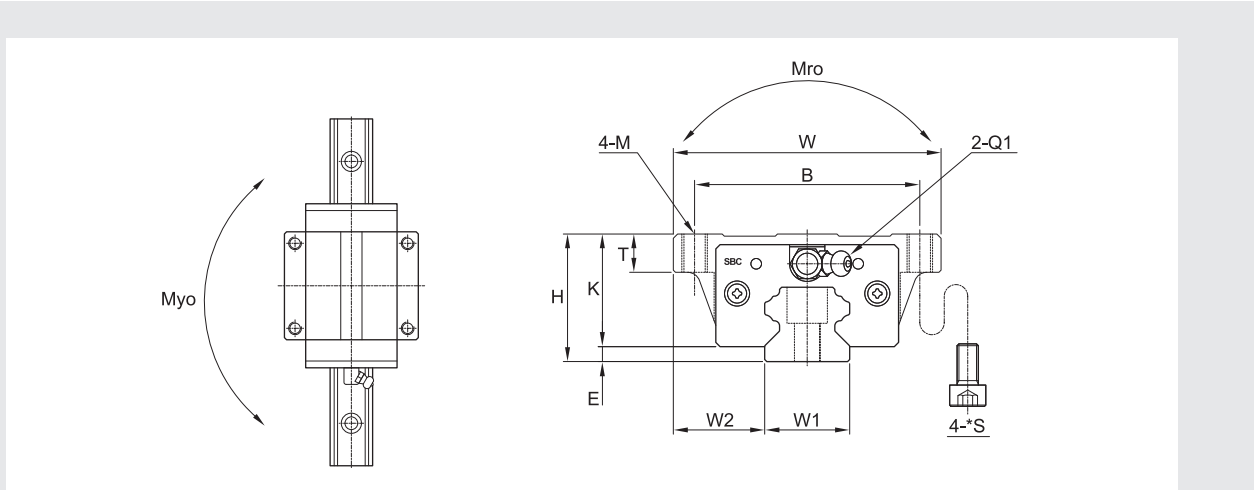

Model	Mounting dimension				Block dimensions												
	H	W	L	E	Mounting tap hole				L1	T	K	Grease fitting					
					B	J	M	*S				T1	N1	T2	N2	Q1	*Q2
SPG20 FL	30	63	77.2	3.5	53	40	M6	M5	50.8	9	26.5	7	12	7	5	M6x0.75	Ø5.5
SPG20 FLL	30	63	93.2	3.5	53	40	M6	M5	66.8	9	26.5	7	12	7	5	M6x0.75	Ø5.5
SPG25 FL	36	70	86.9	6.5	57	45	M8	M6	59.5	10	29.5	8.2	12	8.1	5.5	M6x0.75	Ø5.5
SPG25 FLL	36	70	106.4	6.5	57	45	M8	M6	79	10	29.5	8.2	12	8.1	5.5	M6x0.75	Ø5.5
SPG30 FL	42	90	100	7	72	52	M10	M8	70.4	12	35	8.5	12	8.5	5.5	M6x0.75	Ø5.5
SPG30 FLL	42	90	122.5	7	72	52	M10	M8	92.9	12	35	8.5	12	8.5	5.5	M6x0.75	Ø5.5
SPG35 FL	48	100	112.6	7.5	82	62	M10	M8	80.4	13	40.5	8	12	8	6	M6x0.75	Ø5.5
SPG35 FLL	48	100	138.1	7.5	82	62	M10	M8	105.9	13	40.5	8	12	8	6	M6x0.75	Ø5.5

- ① C (Basic dynamic load rating), Co (Basic static load rating)
- ② *S: Bolt size for bottom mounting type of block.
- ③ *Q2: The hole of side grease nipple is not made to prevent a foreign substance from going into inside.
When you order the side grease nipple, we build it by ourselves.

Linear Rail System

SPG / SPS Spacer Linear Rail System

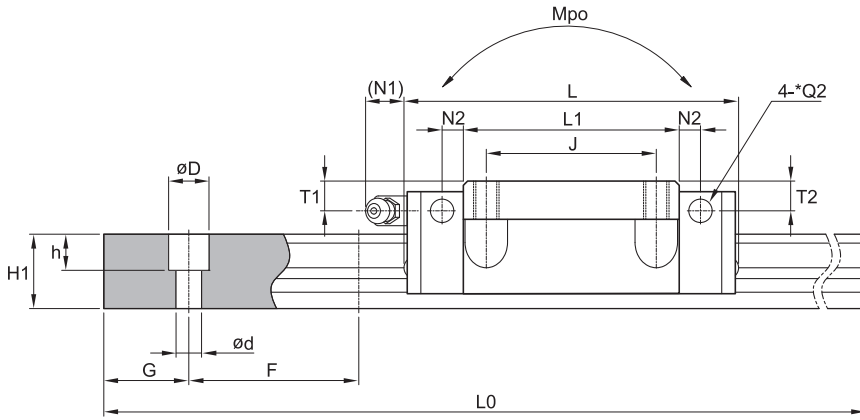

(Unit : mm)

Rail dimension									Basic load rating [kN]		Permissible static moment [kN·m]			Mass	
W1	W2	H1	F	Bolt hole			G	Max length of rail L0	C	Co	Mro	Mpo	Myo	Block [kg]	Rail [kg/m]
				d	D	h									
20	21.5	17.5	60	6	9.5	8.5	20	4000	14.2	25	0.22	0.18	0.18	0.42	2.2
20	21.5	17.5	60	6	9.5	8.5	20	4000	16.9	36.5	0.28	0.31	0.31	0.54	2.2
23	23.5	21.8	60	7	11	9	20	4000	20.9	39.2	0.35	0.31	0.3	0.62	3.1
23	23.5	21.8	60	7	11	9	20	4000	24.6	48	0.43	0.49	0.48	0.78	3.1
28	31	25	80	9	14	12	20	4000	29.2	53.8	0.59	0.49	0.48	1.1	4.45
28	31	25	80	9	14	12	20	4000	35.3	67.9	0.74	0.79	0.78	1.44	4.45
34	33	29	80	9	14	12	20	4000	38.8	68.6	0.94	0.74	0.72	1.57	6.4
34	33	29	80	9	14	12	20	4000	46	90.4	1.24	1.3	1.28	2.14	6.4

Ⓐ Linear Rail System

Ⓑ Ball Screw

Ⓒ Support Unit

Ⓓ Linear Ball Bush

Ⓔ Cross Roller Guide

Ⓕ Robot Carrer Guide

Memo

Linear Rail System

SPG / SPS Spacer Linear Rail System

SPG-SL/SL

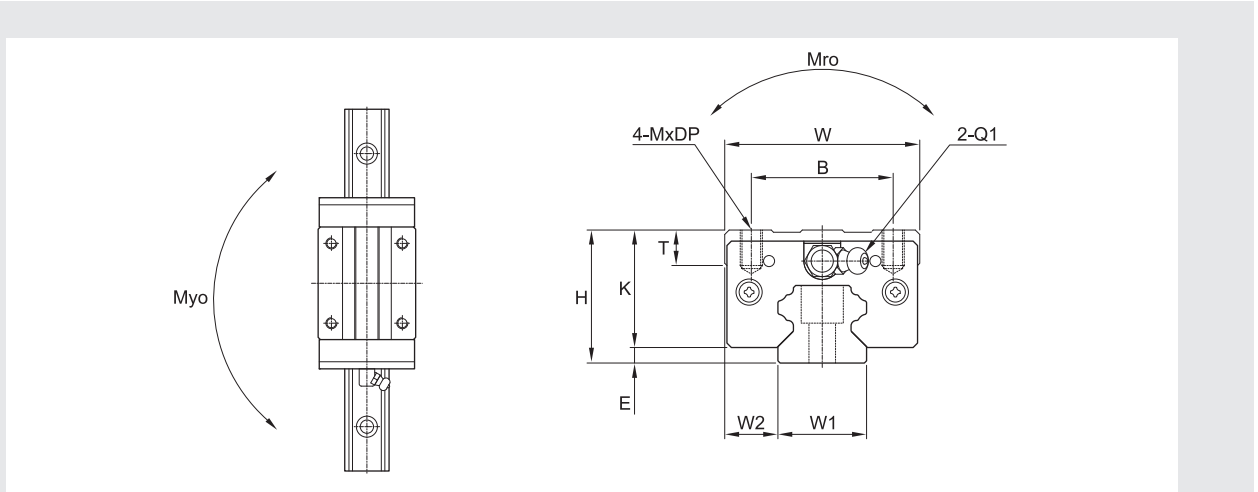

Model	Mounting dimension				Block dimensions												
	H	W	L	E	Mounting tap hole				L1	T	K	Grease fitting					
					B	J	M	DP				T1	N1	T2	N2	Q1	*Q2
SPG20 SL	30	44	77.2	3.5	32	36	M5	8	50.8	8	26.5	8	12	7	5	M6x0.75	Ø5.5
SPG20 SLL	30	44	93.2	3.5	32	50	M5	8	66.8	8	26.5	8	12	7	5	M6x0.75	Ø5.5
SPG25 SL	40	48	86.9	6.5	35	35	M6	8	59.5	12	33.5	12	12	12.2	5.5	M6x0.75	Ø5.5
SPG25 SLL	40	48	106.4	6.5	35	50	M6	8	79	12	33.5	12	12	12.2	5.5	M6x0.75	Ø5.5
SPG30 SL	45	60	100	7	40	40	M8	10	70.4	12	38	12	12	11.5	5.5	M6x0.75	Ø5.5
SPG30 SLL	45	60	122.5	7	40	60	M8	10	92.9	12	38	12	12	11.5	5.5	M6x0.75	Ø5.5
SPG35 SL	55	70	112.6	7.5	50	50	M8	12	80.4	15	47.5	15	12	15	6	M6x0.75	Ø5.5
SPG35 SLL	55	70	138.1	7.5	50	72	M8	12	105.9	15	47.5	15	12	15	6	M6x0.75	Ø5.5

① C (Basic dynamic load rating), Co (Basic static load rating)

② *Q2: The hole of side grease nipple is not made to prevent a foreign substance from going into inside.
When you order the side grease nipple, we build it by ourselves.

Linear Rail System

SPG / SPS Spacer Linear Rail System

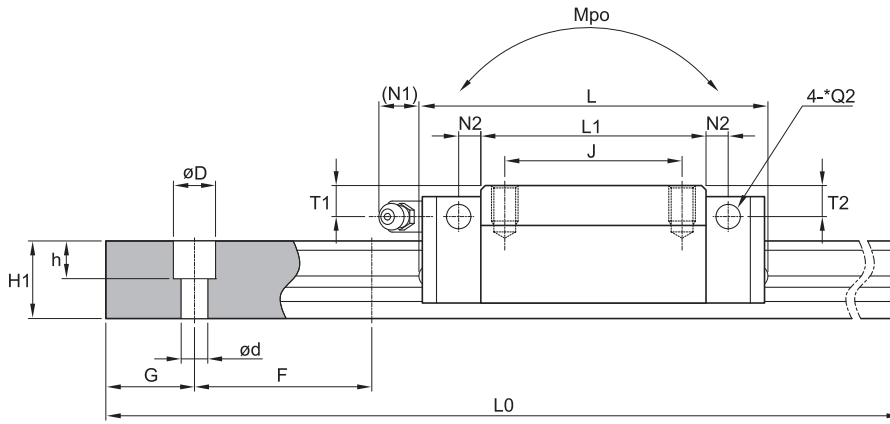

(Unit : mm)

Rail dimension									Basic load rating [kN]		Permissible static moment [kN·m]			Mass	
W1	W2	H1	F	Bolt hole			G	Max length of rail L0	C	Co	Mro	Mpo	Myo	Block [kg]	Rail [kg/m]
				d	D	h									
20	12	17.5	60	6	9.5	8.5	20	4000	14.2	25	0.22	0.18	0.18	0.33	2.2
20	12	17.5	60	6	9.5	8.5	20	4000	16.9	36.5	0.28	0.31	0.31	0.45	2.2
23	12.5	21.8	60	7	11	9	20	4000	20.9	39.2	0.35	0.31	0.3	0.56	3.1
23	12.5	21.8	60	7	11	9	20	4000	24.6	48	0.43	0.49	0.48	0.73	3.1
28	16	25	80	9	14	12	20	4000	29.2	53.8	0.59	0.49	0.48	0.98	4.45
28	16	25	80	9	14	12	20	4000	35.3	67.9	0.74	0.79	0.78	1.28	4.45
34	18	29	80	9	14	12	20	4000	38.8	68.6	0.94	0.74	0.72	1.63	6.4
34	18	29	80	9	14	12	20	4000	46	90.4	1.24	1.3	1.28	2.12	6.4

ⓐ Linear Rail System

ⓑ Ball Screw

ⓒ Support Unit

ⓓ Linear Ball Bush

ⓔ Cross Roller Guide

ⓕ Robot Carrer Guide

Memo

Linear Rail System

SPG / SPS Spacer Linear Rail System

SPS-SL, HL/SLL, HL

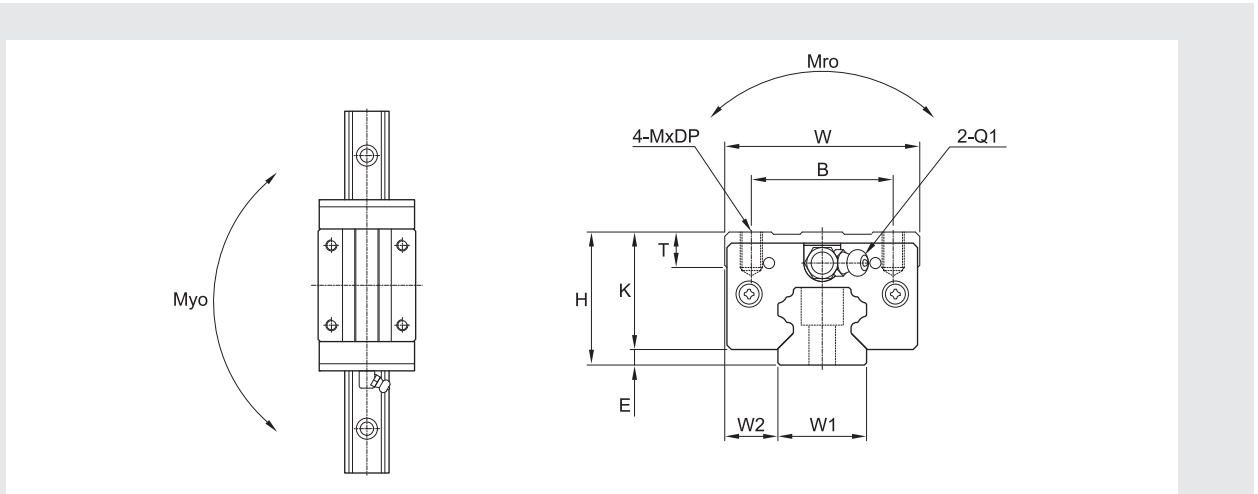

Model	Mounting dimension				Block dimensions													
	H	W	L	E	Mounting tap hole				L1	T	K	Grease fitting						
					B	J	M	DP				T1	N1	T2	N2	Q1	*Q2	
SPS20 SL	28	44	77.2	3.5	32	32	M5	7	50.8	7.5	24.5	5	12	5	5	M6x0.75	Ø5.5	
SPS20 SLL	28	44	93.2	3.5	32	50	M5	7	66.8	7.5	24.5	5	12	5	5	M6x0.75	Ø5.5	
SPS25 SL	33	48	86.9	6.5	35	35	M6	6	59.5	8	26.5	5.2	12	5.1	5.5	M6x0.75	Ø5.5	
SPS25 SLL	33	48	106.4	6.5	35	50	M6	6	79	8	26.5	5.2	12	5.1	5.5	M6x0.75	Ø5.5	
SPS25 HL	36	48	86.9	6.5	35	35	M6	8	59.5	11	29.5	8.2	12	8.1	5.5	M6x0.75	Ø5.5	
SPS25 HLL	36	48	106.4	6.5	35	50	M6	8	79	11	29.5	8.2	12	8.1	5.5	M6x0.75	Ø5.5	
SPS30 SL	42	60	100	7	40	40	M8	10	70.4	12	35	8.5	12	8.5	5.5	M6x0.75	Ø5.5	
SPS30 SLL	42	60	122.5	7	40	60	M8	10	92.9	12	35	8.5	12	8.5	5.5	M6x0.75	Ø5.5	
SPS35 SL	48	70	112.6	7.5	50	50	M8	12	80.4	15	40.5	8	12	8	6	M6x0.75	Ø5.5	
SPS35 SLL	48	70	138.1	7.5	50	72	M8	12	105.9	15	40.5	8	12	8	6	M6x0.75	Ø5.5	

- ① C (Basic dynamic load rating), Co (Basic static load rating)
- ② *Q2: The hole of side grease nipple is not made to prevent a foreign substance from going into inside.
When you order the side grease nipple, we build it by ourselves.

Linear Rail System

SPG / SPS Spacer Linear Rail System

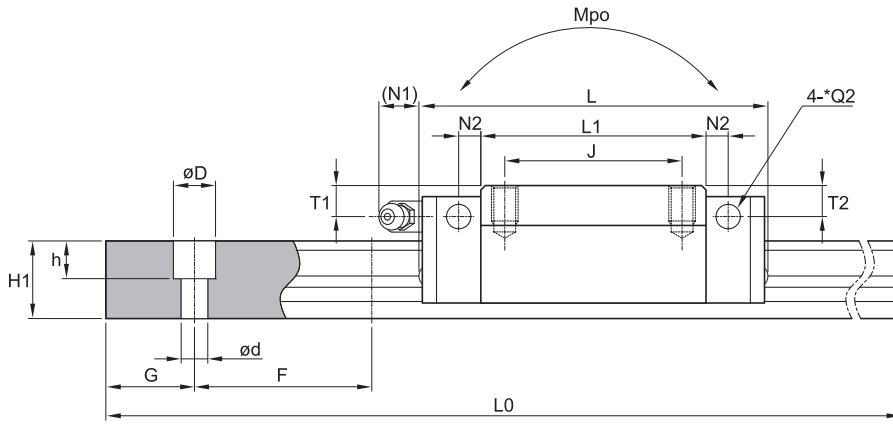

(Unit : mm)

Rail dimension									Basic load rating [kN]		Permissible static moment [kN·m]			Mass	
W1	W2	H1	F	Bolt hole			G	Max length of rail L0	C	Co	Mro	Mpo	Myo	Block [kg]	Rail [kg/m]
				d	D	h									
20	12	17.5	60	6	9.5	8.5	20	4000	14.2	25	0.22	0.18	0.18	0.33	2.2
20	12	17.5	60	6	9.5	8.5	20	4000	16.9	36.5	0.28	0.31	0.31	0.45	2.2
23	12.5	21.8	60	7	11	9	20	4000	20.9	39.2	0.35	0.31	0.3	0.56	3.1
23	12.5	21.8	60	7	11	9	20	4000	24.6	48	0.43	0.49	0.48	0.73	3.1
23	12.5	21.8	60	7	11	9	20	4000	20.9	39.2	0.35	0.31	0.3	0.98	3.1
23	12.5	21.8	60	7	11	9	20	4000	24.6	48	0.43	0.49	0.48	1.28	3.1
28	16	25	80	9	14	12	20	4000	29.2	53.8	0.59	0.49	0.48	0.98	4.45
28	16	25	80	9	14	12	20	4000	35.3	67.9	0.74	0.79	0.78	1.28	4.45
34	18	29	80	9	14	12	20	4000	38.8	68.6	0.94	0.74	0.72	1.63	6.4
34	18	29	80	9	14	12	20	4000	46	90.4	1.24	1.3	1.28	2.12	6.4

Ⓐ Linear Rail System

Ⓑ Ball Screw

Ⓒ Support Unit

Ⓓ Linear Ball Bush

Ⓔ Cross Roller Guide

Ⓕ Robot Carrer Guide

Memo

Linear Rail System

SPG / SPS Spacer Linear Rail System

SPS-FV

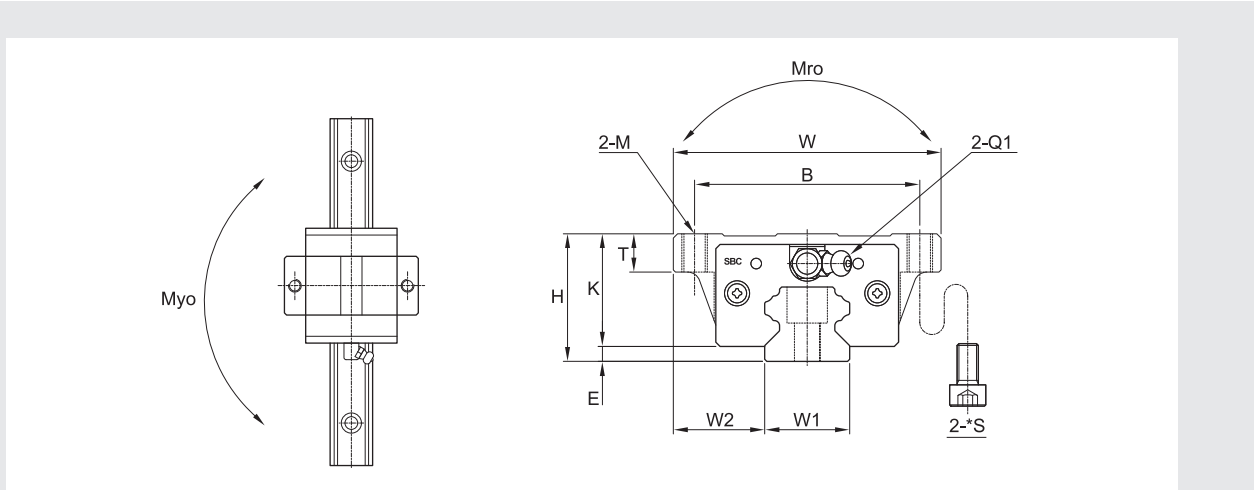

Model	Mounting dimension				Block dimensions											
	H	W	L	E	Mounting tap hole			L1	T	K	Grease fitting					
					B	M	*S				T1	N1	T2	N2	Q1	*Q2
SPS20 FV	28	63	54.2	3.5	53	M6	M5	27.8	7	24.5	5	12	5	5	M6x0.75	Ø5.5
SPS25 FV	33	70	62.6	6.5	57	M8	M6	35.2	7	26.5	5.2	12	5.1	5.5	M6x0.75	Ø5.5

- ① C (Basic dynamic load rating), Co (Basic static load rating)
- ② *S: Bolt size for bottom mounting type of block.
- ③ *Q2: The hole of side grease nipple is not made to prevent a foreign substance from going into inside.
When you order the side grease nipple, we build it by ourselves.

Linear Rail System

SPG / SPS Spacer Linear Rail System

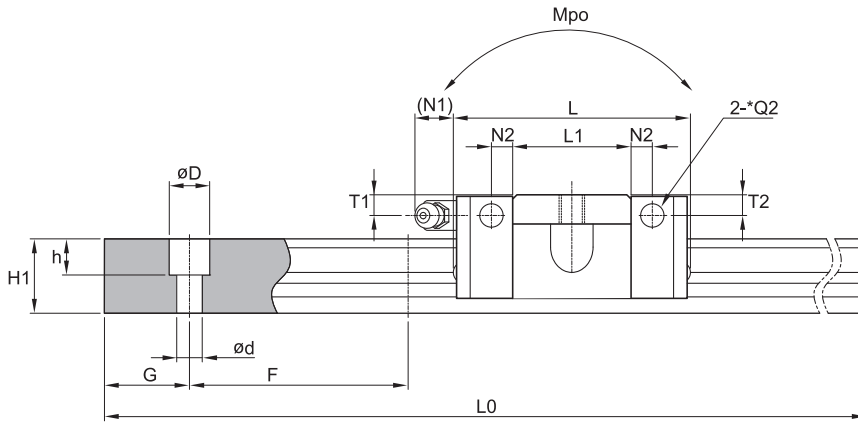

(Unit : mm)

Rail dimension									Basic load rating [kN]		Permissible static moment [kN·m]			Mass	
W1	W2	H1	F	Bolt hole			G	Max length of rail L0	C	Co	Mro	Mpo	Myo	Block [kg]	Rail [kg/m]
				d	D	h									
20	21.5	17.5	60	6	9.5	8.5	20	4000	7.65	13.5	0.12	0.1	0.1	0.24	2.2
23	23.5	21.8	60	7	11	9	20	4000	11.29	21.1	0.19	0.17	0.17	0.37	3.1

① Linear Rail System

② Ball Screw

③ Support Unit

④ Linear Ball Bush

⑤ Cross Roller Guide

⑥ Robot Carrer Guide

Memo

Linear Rail System

SPG / SPS Spacer Linear Rail System

SPS-SV

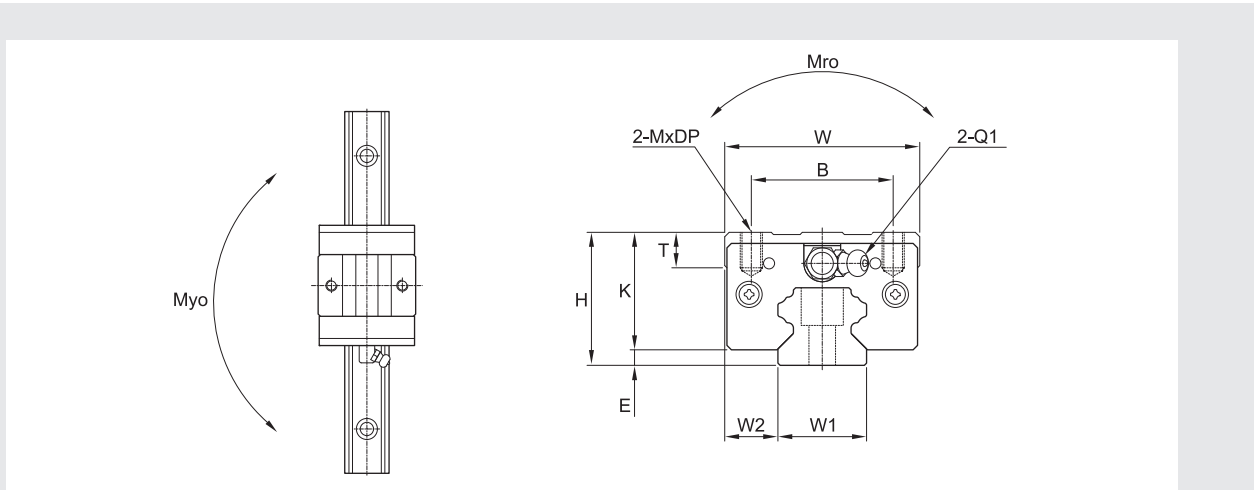

Model	Mounting dimension				Block dimensions											
	H	W	L	E	Mounting tap hole			L1	T	K	Grease fitting					
					B	M	DP				T1	N1	T2	N2	Q1	*Q2
SPS20 SV	28	44	54.2	3.5	32	M5	7	27.8	7.5	24.5	5	12	5	5	M6x0.75	Ø5.5
SPS25 SV	33	48	62.6	6.5	35	M6	6	35.2	8	26.5	5.2	12	5.1	5.5	M6x0.75	Ø5.5

- ① C (Basic dynamic load rating), Co (Basic static load rating)
- ② *Q2: The hole of side grease nipple is not made to prevent a foreign substance from going into inside.
When you order the side grease nipple, we build it by ourselves.

Linear Rail System

SPG / SPS Spacer Linear Rail System

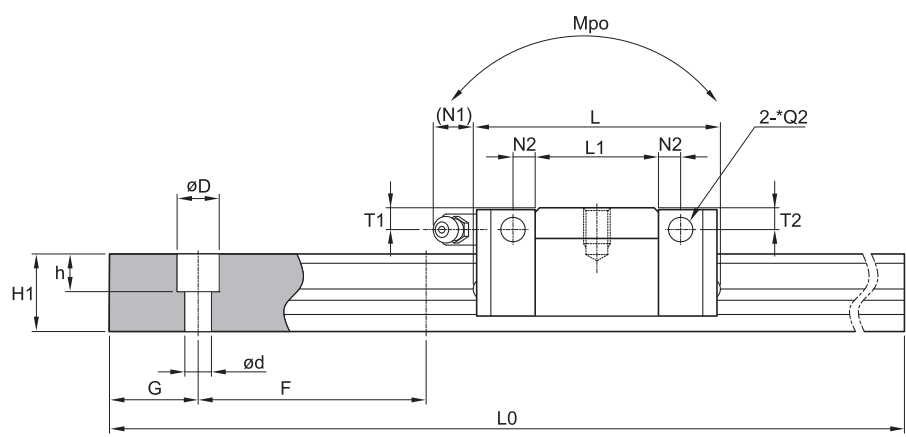

(Unit : mm)

Rail dimension									Basic load rating [kN]		Permissible static moment [kN·m]			Mass	
W1	W2	H1	F	Bolt hole			G	Max length of rail L0	C	Co	Mro	Mpo	Myo	Block [kg]	Rail [kg/m]
				d	D	h									
20	12	17.5	60	6	9.5	8.5	20	4000	7.65	13.5	0.12	0.1	0.1	0.19	2.2
23	12.5	21.8	60	7	11	9	20	4000	11.29	21.1	0.19	0.17	0.17	0.32	3.1

Ⓐ Linear Rail System

Ⓑ Ball Screw

Ⓒ Support Unit

Ⓓ Linear Ball Bush

Ⓔ Cross Roller Guide

Ⓕ Robot Carrer Guide

Memo

Linear Rail System

Miniature Linear Rail System

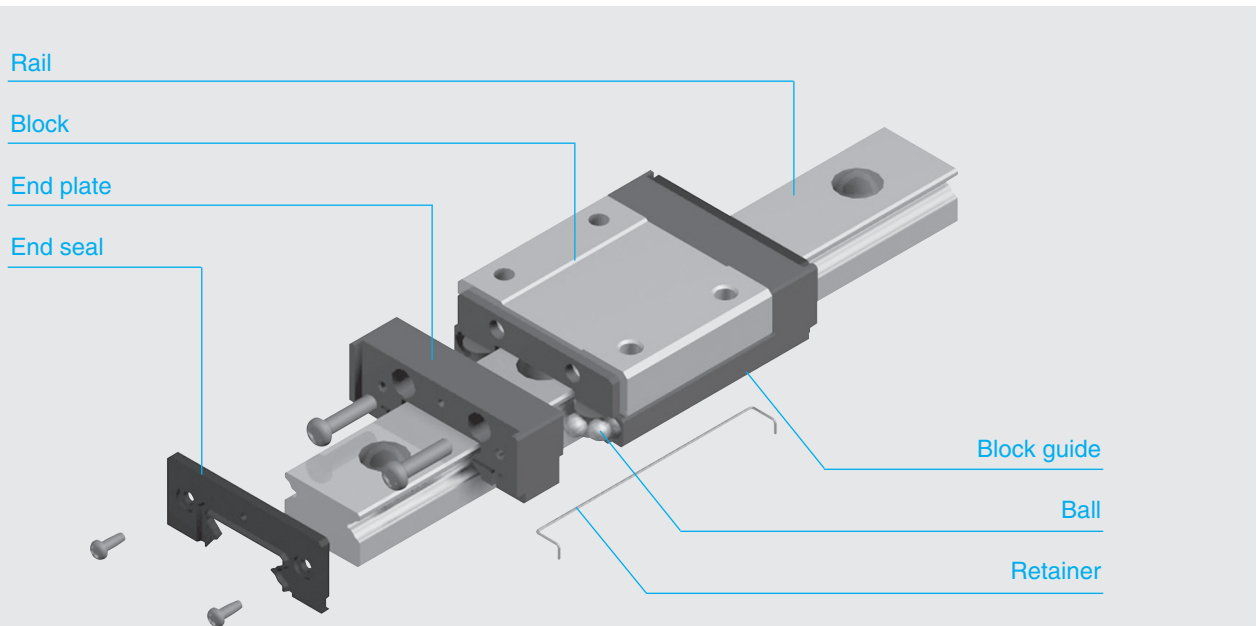

[Feature of structure]

SBC Miniature linear rail system utilizes two rows of ball bearings which make four point contact between the rail and block. This design achieves both a slim profile and high rigidity. The special engineered plastic is used for the end-plate allows for long life ball recirculation.

[Ball retention]

To retain the ball bearings inside the block, a wire retainer is used between the block and rail. With this retainer, the block can be carefully removed from the rail without losing ball bearings.

[Low noise]

With a ball return path made from engineered plastic, contact noise between the balls and block wall is removed, therefore achieving low noise.

[Smooth movement]

The steel block, ball returns, and end caps are carefully engineered to act as a single path enabling smooth operation in both horizontal and vertical applications.

[Excellent corrosion resistance]

Both the rail and block are made from stainless steel for excellent corrosion resistance. This is ideal for semiconductor, life science, LCD, or other clean room production environments.

Linear Rail System

Miniature Linear Rail System

Types and features

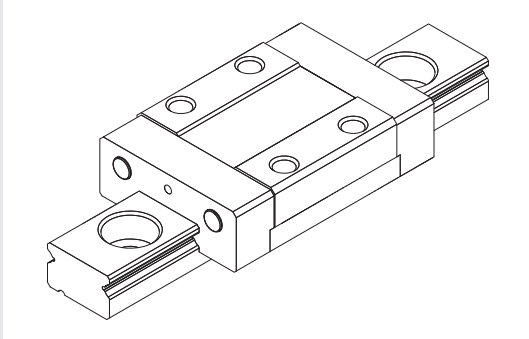

[SBM type]

Standard type of miniature.

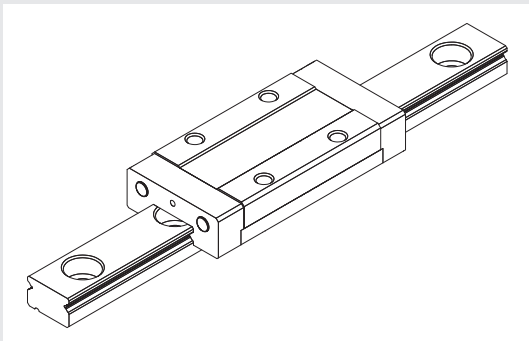

[SBML type]

Block length is modified type to increase load capacity.

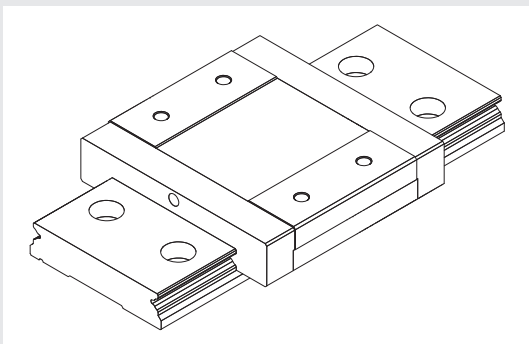

[SBMW type]

The width and length of linear block and rail are modified to increase load ratings and permissible moments.

㉓ Linear Rail System

㉔ Ball Screw

㉕ Support Unit

㉖ Linear Ball Bush

㉗ Cross Roller Guide

㉘ Robot Carrer Guide

Memo

Linear Rail System

Miniature Linear Rail System

Accuracy

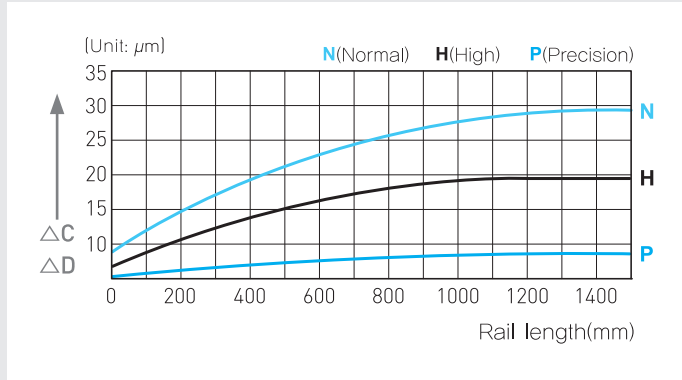
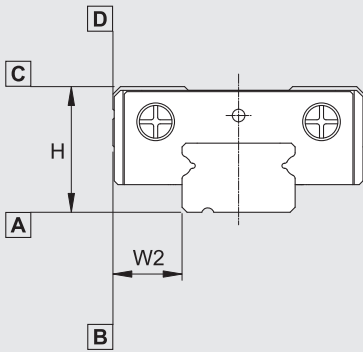

(Unit : mm)

Item	N	H	P
Tolerance for the height H	±0.04	±0.02	±0.01
Tolerance for the rail-to-block lateral distance W2	±0.04	±0.025	±0.015
Tolerance for the height H difference among blocks	0.03	0.015	0.007
Tolerance for rail-to-block lateral distance W2 distance among blocks	0.03	0.015	0.007
Running parallelism of surface C with surface A	ΔC		
Running parallelism of surface D with surface B	ΔD		

● N : Normal ● H : High ● P : Precision

[Preload]

Reference	Volume of preload
K1	Max. 0.02C
K2	0.04 ~ 0.06C

[Seal resistance]

(Unit : N)

Reference	SBM/SBML	SBMW
09	0.2	0.8
12	0.59	1.1
15	1.18	1.3

[Grease]

SBM(L), SBMW Uses two types of grease according to working conditions.
For details, please see the technical data for grease.

Linear Rail System

Miniature Linear Rail System

Shoulder height and fillet radius R

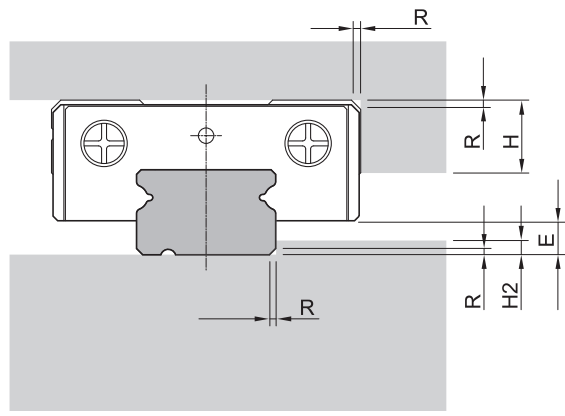

(Unit : mm)

Model number	Fillet radius R	Shoulders height H1	Shoulders height H2	E
SBM(L)09	0.3	3	1.9	2.2
SBM(L)12	0.3	4	2	3
SBM(L)15	0.3	5	2.5	4
SBMW09	0.3	3	3.4	3.7
SBMW12	0.3	4	3.7	4
SBMW15	0.3	5	3.4	3.7

㉓ Linear Rail System

㉔ Ball Screw

㉕ Support Unit

㉖ Linear Ball Bush

㉗ Cross Roller Guide

㉘ Robot Carrer Guide

Memo

Linear Rail System

Miniature Linear Rail System

Permissible tolerance (P) of parallelism

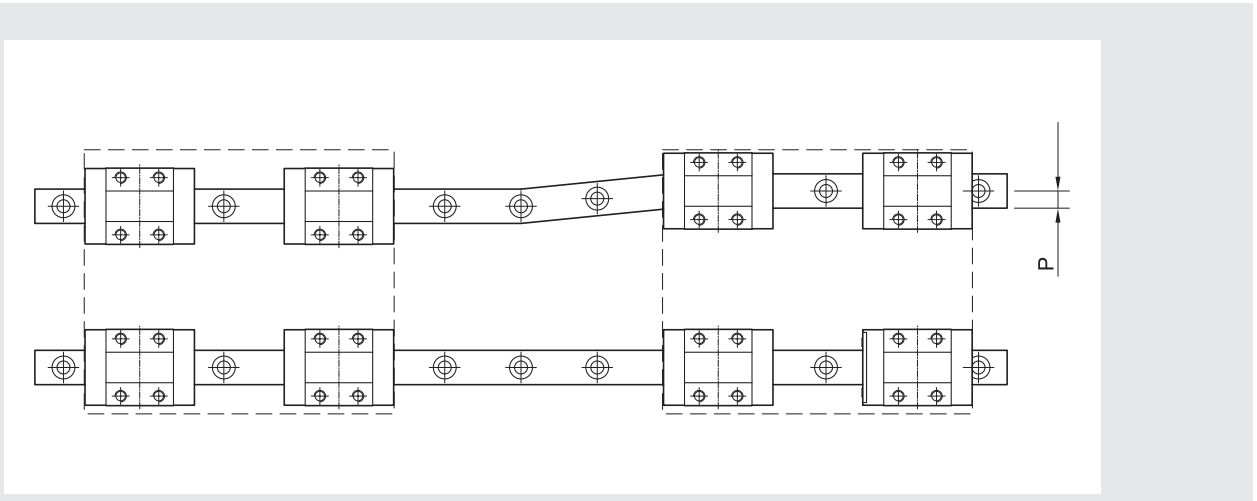

(Unit : μm)

Model size	K1	K2
09	4	3
12	9	5
15	10	6

Linear Rail System

Miniature Linear Rail System

Permissible tolerance (S) of two level offset

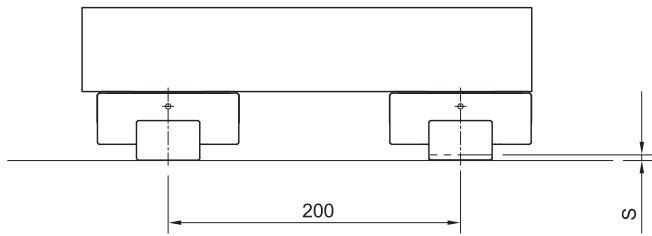

(Unit : μm)

Model size	K1	K2
09	35	6
12	50	12
15	60	20

㉓ Linear Rail System

㉔ Ball Screw

㉕ Support Unit

㉖ Linear Ball Bush

㉗ Cross Roller Guide

㉘ Robot Carrer Guide

Memo

Linear Rail System

Miniature Linear Rail System

Ordering example

[Seal resistance]

SBM09 – K1
[1] [2]

- [1] Model : SBM, SBML, SBMW
[2] Preload : K1, K2

[Ordering example for rail]

SBM09 – 600L – B
[1] [2] [3]

- [1] Model : SBM, SBMW
[2] Rail length
[3] Through tap hole rail : Standard (No symbol)
※ If only rail is ordered, N grade is available.

[Ordering for assembled rail and block]

SBM09 – 2 – K1 – 600 – N – R – B – II
[1] [2] [3] [4] [5] [6] [7] [8]

- [1] Model : SBM, SBML, SBMW
[2] Block quantity on rail
[3] Preload : K1, K2
[4] Rail length
[5] Accuracy : N, H, P
[6] Surface treatment
[7] Through tap hole rail : Standard (No symbol)
[8] Rail : Number of rails per axis 1=I, 2=II... 4=IV etc.
※ We recommend block and rail assembled to be ordered where high-precision and high-rigidity are required.
※ For surface treatment, please mark according to each surface treatment symbol.
※ If special G dimension is required, please mark when you place an order.

Linear Rail System

Miniature Linear Rail System

Standard and Max length

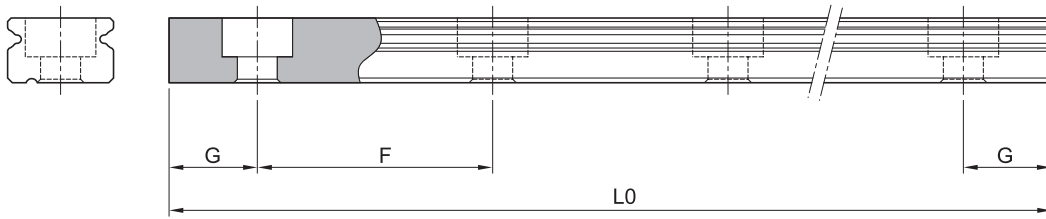

(Unit : mm)

Model number	SBM(L)09	SBM(L)12	SBM(L)15	SBMW09	SBMW12	SBMW15
Standard length	55	70	70	50	70	110
	75	95	110	80	110	150
	95	120	150	110	150	190
	115	145	190	140	190	230
	135	170	230	170	230	270
	155	195	270	200	270	350
	175	220	310	260	350	430
	215	245	350	320	430	510
	255	270	390	380	510	590
	295	320	430	440	590	670
	355	395	470	500	670	750
	415	470	590	560	750	830
	495	545	670	620	830	910
	535	620	830	680	910	990
	615	695	910	740	990	1070
	675	770	990	800	1070	1190
	715	870	1070	860	1190	
	735	970	1190	920		
	795	1020		980		
	875	1195		1040		
955			1100			
995			1190			
1035						
1115						
1195						
F	20	25	40	30	40	40
G	7.5	10	15	10	15	15
L0(Max length)	1195	1195	1190	1190	1190	1190

* SBM, SBML use same rail.

* If special G dimension is required, please mark when you place an order.

@ Linear Rail System

@ Ball Screw

@ Support Unit

@ Linear Ball Bush

@ Cross Roller Guide

@ Robot Carrer Guide

Memo

Linear Rail System

Miniature Linear Rail System

Miniature through tap hole rail

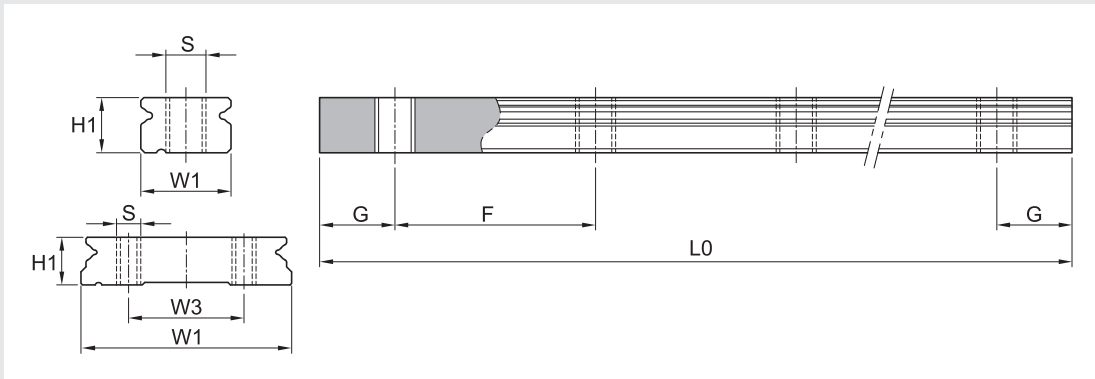

(Unit : mm)

Model	W1	W3	H1	S	G	F	L0 (Max length)	Mass (kg/m)
SBM 09-B	9	-	5.5	M4x0.7	7.5	20	1195	0.32
SBM 12-B	12	-	7.5	M4x0.7	10	25	1195	0.32
SBM 15-B	15	-	9.5	M4x0.7	15	40	1190	0.59
SBMW 09-B	18	-	7.5	M4x0.7	10	30	1190	0.99
SBMW 12-B	24	-	8.5	M5x0.8	15	40	1190	1.42
SBMW 15-B	42	23	9.5	M5x0.8	15	40	1190	2.93

Linear Rail System

Miniature Linear Rail System

Caution for mounting miniature through tap hole rail

If the mounting bolt is longer than overall mounting height, the bolt can protrude which can cause interference with the seal or bearing itself. Therefore, make sure the appropriate bolt selection.

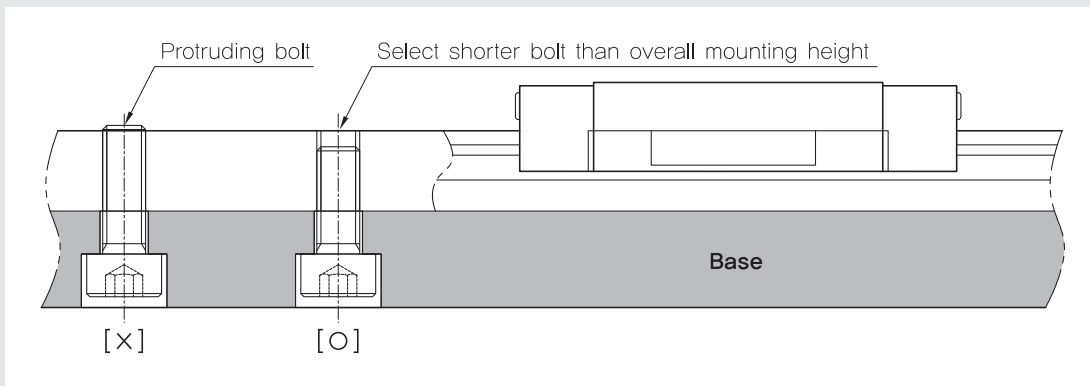

③ Linear Rail System

④ Ball Screw

⑤ Support Unit

⑥ Linear Ball Bush

⑦ Cross Roller Guide

⑧ Robot Carrier Guide

Memo

Linear Rail System

Miniature Linear Rail System

SBM/SBML

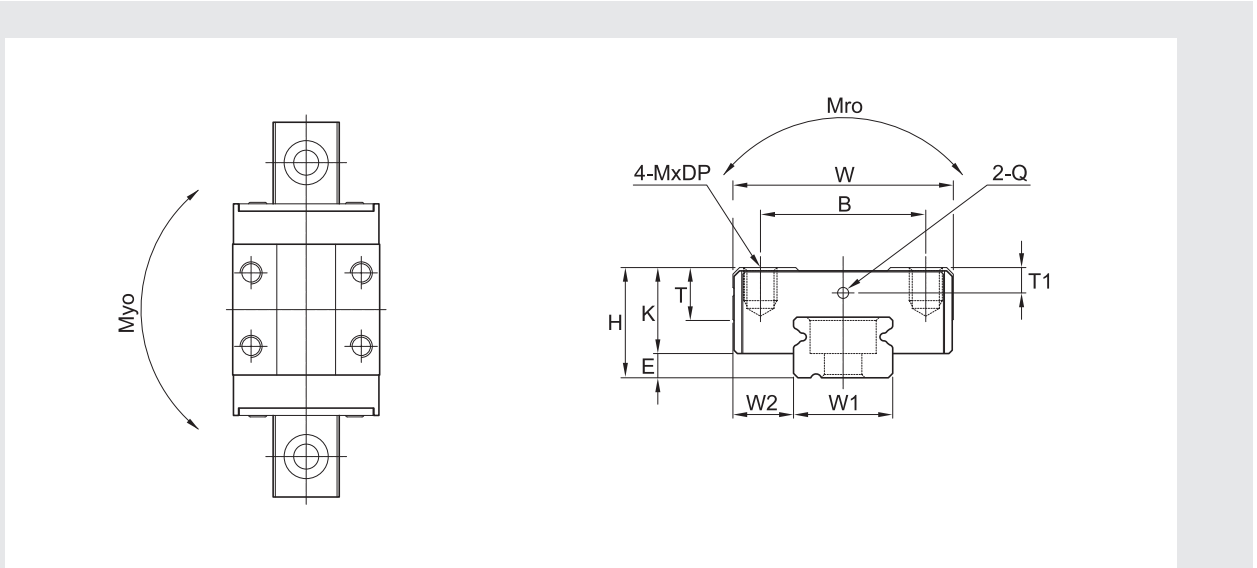

Model	Mounting dimension				Block dimensions									
	H	W	L	E	Mounting tap hole				L1	T	K	Greasing hole		
					B	J	M	DP				T1	Q	
SBM 09	10	20	30.4	2.2	15	10	M3	3	17.8	5	7.8	2.3	Ø1	
SBML 09	10	20	40.8	2.2	15	16	M3	3	28.2	5	7.8	2.3	Ø1	
SBM 12	13	27	35	3	20	15	M3	3.5	19.8	6	10	2.8	Ø1	
SBML 12	13	27	47.6	3	20	20	M3	3.5	32.4	6	10	2.8	Ø1	
SBM 15	16	32	43	4	25	20	M3	4	25.4	7	12	3.1	Ø1	
SBML 15	16	32	58.8	4	25	25	M3	4	41.2	7	12	3.1	Ø1	

① C (Basic dynamic load rating), Co (Basic static load rating)

Linear Rail System

Miniature Linear Rail System

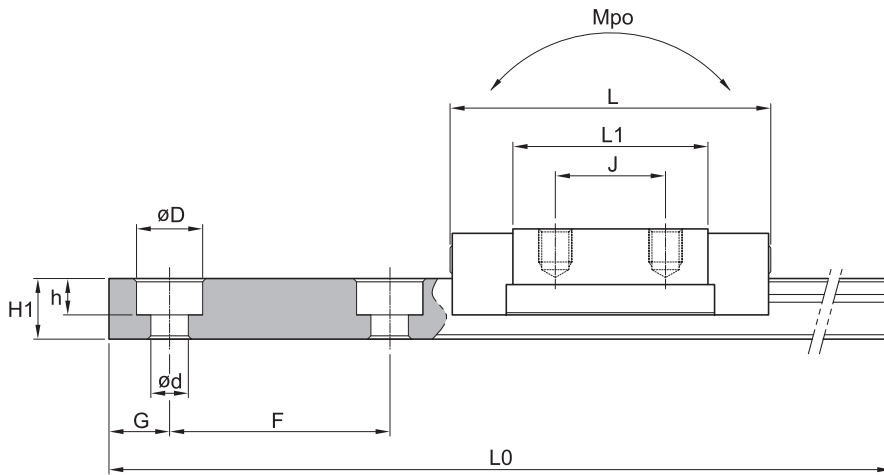

(Unit : mm)

Rail dimension									Basic load rating [kN]		Permissible static moment [N · m]			Mass	
W1	W2	H1	F	Bolt hole			G	Max length of rail L0	C	Co	Mro	Mpo	Myo	Block [kg]	Rail [kg/m]
				d	D	h									
9	5.5	5.5	20	4	6	3.3	7.5	1195	1.4	2.7	12.15	6.01	6.01	0.013	0.32
9	5.5	5.5	20	4	6	3.3	7.5	1195	2.1	4.6	20.7	16.22	16.22	0.023	0.32
12	7.5	7.5	25	4	6	4.5	10	1195	3.3	4.9	29.4	12.13	12.13	0.029	0.59
12	7.5	7.5	25	4	6	4.5	10	1195	5	9.1	54.6	36.86	36.86	0.043	0.59
15	8.5	9.5	40	4	6	4.5	15	1190	4.9	7.5	56.25	23.81	23.81	0.052	0.99
15	8.5	9.5	40	4	6	4.5	15	1190	7.1	12.9	96.75	66.44	66.44	0.079	0.99

㉓ Linear Rail System

㉔ Ball Screw

㉕ Support Unit

㉖ Linear Ball Bush

㉗ Cross Roller Guide

㉘ Robot Carrer Guide

Memo

Linear Rail System

Miniature Linear Rail System

SBMW

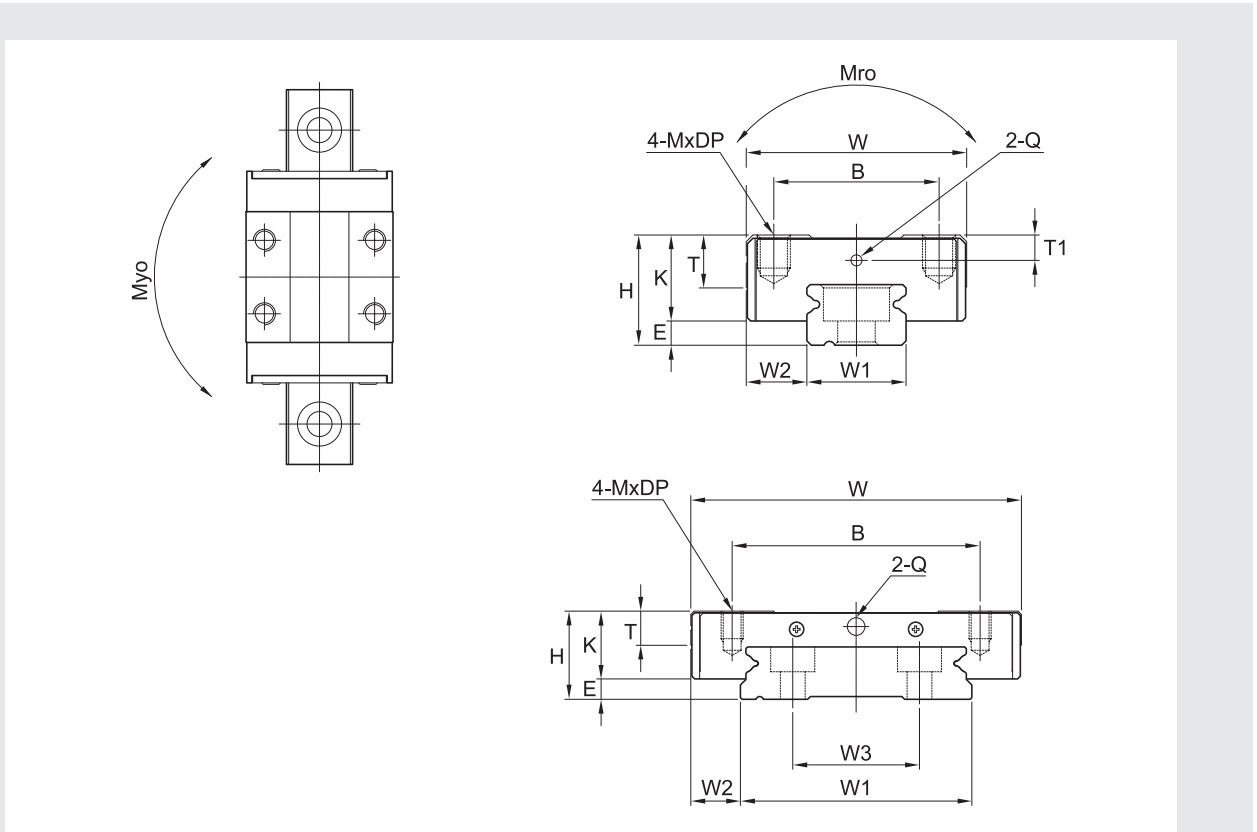

Model	Mounting dimension				Block dimensions									
	H	W	L	E	Mounting tap hole				L1	T	K	Greasing hole		
					B	J	M	DP				T1	Q	
SBMW 09	12	30	42.3	3.7	21	12	M3	3	27	4.5	8.3	2	Ø1.4	
SBMW 12	14	40	48.4	4	28	15	M3	3.5	30.9	5	10	2.4	Ø1.6	
SBMW 15	16	60	57.5	3.7	45	20	M3	4.5	38.9	6.2	12.3	2.8	Ø3.2	

① C (Basic dynamic load rating), Co (Basic static load rating)

Linear Rail System

Miniature Linear Rail System

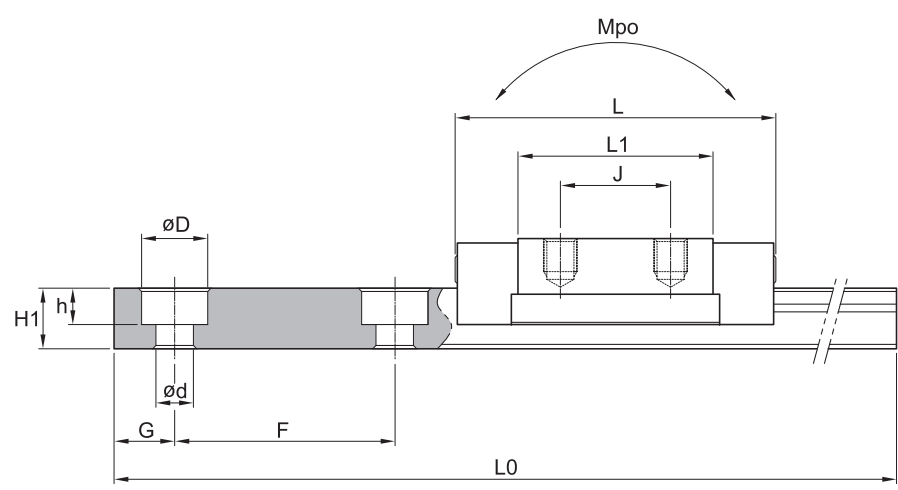

(Unit : mm)

Rail dimension										Basic load rating [kN]		Permissible static moment [N · m]			Mass	
W1	W2	H1	W3	F	Bolt hole			G	Max length of rail L0	C	Co	Mro	Mpo	Myo	Block [kg]	Rail [kg/m]
					d	D	h									
18	6	7.5	-	30	3.5	6	4.5	10	1190	2.45	3.92	35.96	16.26	16.26	0.03	0.99
24	8	8.5	-	40	4.5	8	4.5	15	1190	4.02	6.08	47.62	17.15	18.62	0.03	1.42
42	9	9.5	23	40	4.5	8	4.5	15	1190	6.66	9.80	136.9	35.28	38.22	0.12	2.93

㉓ Linear Rail System

㉔ Ball Screw

㉕ Support Unit

㉖ Linear Ball Bush

㉗ Cross Roller Guide

㉘ Robot Carrer Guide

Memo