

STRONG AND COMPACT

Full disengagement

TORQUE LIMITERS

SERIES ST | 1,000 – 160,000 Nm



R+W[®]
COUPLING TECHNOLOGY

THE ULTIMATE COUPLUNG FROM 1,000 – 160,000 Nm

www.rwcouplings.com



SERIES ST

TORQUE LIMITERS

Reliable torque overload protection

The usage of ST Torque Limiters minimizes machine downtimes as a result of a crash and ensures the availability and productivity of your machine.

ST Torque Limiters are designed for high torque capacities which are achieved by strong modules evenly spread on the circumference.

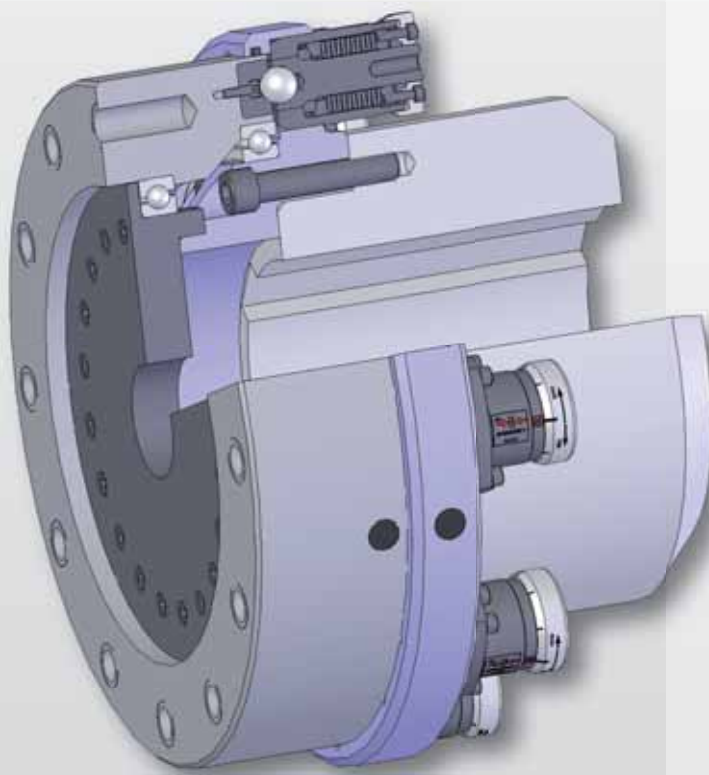

The modules consist of two components, the re-engagement module and the adjustable module. The set torque is easily visible on a scale.

Table of contents

Coupling designs	Page 3
Torque Limiter Model ST1	Page 4-5
Torque Limiters Model ST2 / ST3	Page 6
Mounting instructions Model ST1 / ST2 / ST3	Page 7
Module ST	Page 8-9
Accessories	Page 10
Selection	Page 11
Product range	Seite 12

The R+W torque limiter model TS is based on a spring loaded form fit design.

The transmittable torque is determined by the number of modules that are evenly spread on the circumference and their bolt circle diameters.

In the event of a torque overload the balls jump out of the detents in axial direction resulting in a permanent separation of the drive and driven elements.

An axial force on the plunger re-engages the module.

Dust and dirt penetration is prevented by the sealed torque limiter design.

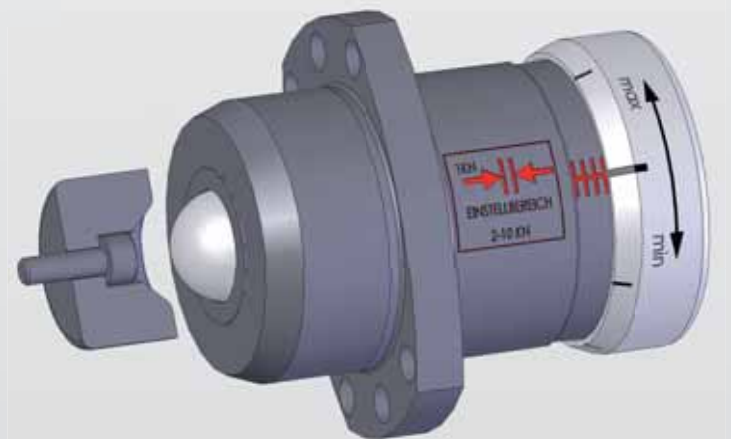

Areas of application

Heavy duty applications

- Excavators
- Dredgers
- Turbine construction
- Sluice drives
- Rolling mills
- Steel mills
- Large lifting devices

Features

- Compact, simple design
- Full disengagement
- Precise overload protection
- Torsionally rigid
- Infinite life
- Wear and maintenance free

MODELS

FEATURES

POSSIBLE APPLICATIONS

ST 1



Torque Limiter for indirect drives

- Compact, simple design
- Precise overload protection
- Torsionally rigid
- Integral bearings for timing belt, pulley or sprocket

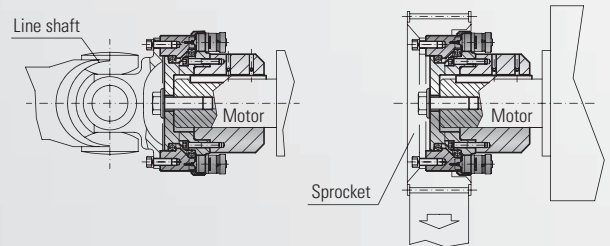

ST 2



Torque Limiter for direct drives

- Compensation for misalignments
- Precise overload protection
- Torsionally rigid
- Vibration damping

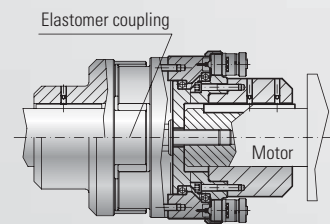

ST 3



Torque Limiter for direct drives

- Torsionally rigid
- Compensation for misalignments
- Precise overload protection

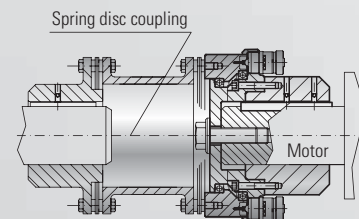

ST



Modules for mounting in linear and rotary coupling systems

- Subsequent incorporation of modules possible
- Full disengagement
- Torsionally rigid
- Infinite life, wear and maintenance free
- Adjustable

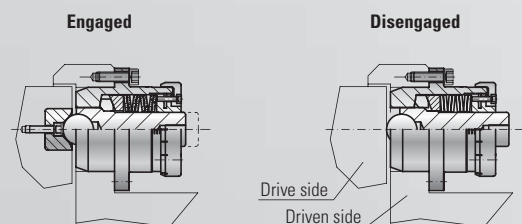

optional
stainless
steel

Full disengagement

MODEL ST1

TORQUE LIMITER



with keyway connection

Material:

High strength hardened steel (oxidized surface)

Design:

Drive side: Coupling hub with keyway connection or spline profile

Output side: Adapter flange with 12x fastening threads. The bearing is integrated.

Modules: Evenly spread on the circumference. Adjustable within the adjustment range.

Temperature range:

-30° C to +120° C

Service life:

Couplings are maintenance free and have extreme service life as long as the performance limits are not exceeded.

Fit tolerance:

Tolerance between hub and shaft 0,02 – 0,07 mm

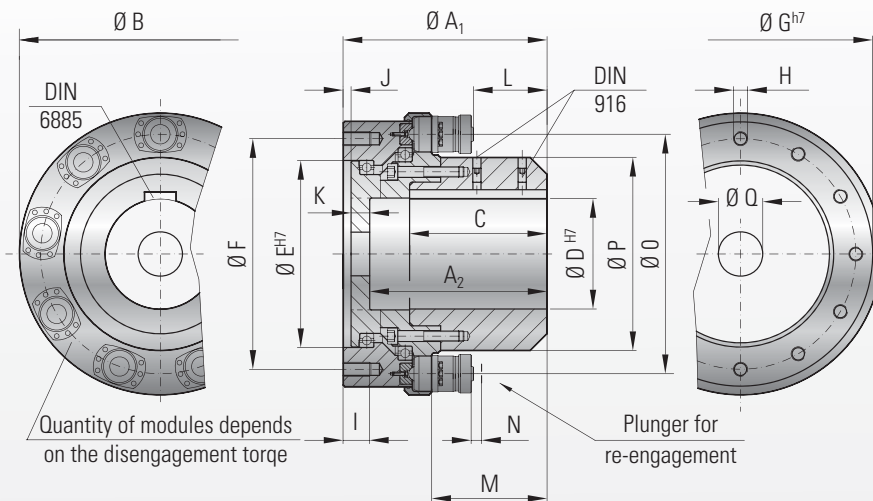

Quantity of modules depends on the disengagement torque

Plunger for re-engagement

Model ST 1		Series											
		10			25			60			160		
Adjustment range available from – to integrated modules (ST) (KNm)		1-6	2-10	6-18	2-8	4-15	10-25	8-18	15-35	30-60	20-50	40-100	80-160
		3 x ST 15	6 x ST 15	9 x ST 15	3 x ST 15	6 x ST 15	9 x ST 15	3 x ST 30	6 x ST 30	9 x ST 30	3 x ST 70	6 x ST 70	9 x ST 70
Overall length (mm)	A ₁	183			230			320			410		
Length to block (mm)	A ₂	158			200			275			360		
Flange diameter (mm)	B	270			318			459			648		
Fit length (mm)	C	120			155			220			290		
Bore diameter possible from Ø to Ø H7 (mm)	D	40-110			60-140			80-200			100-290		
Flange centering diameter H7 (mm)	E	170			210			300			450		
Bolt circle diameter ± 0,3 (mm)	F	220			260			370			570		
Outer diameter h7 (mm)	G	259			298			418			618		
Fastening threads	H	10 x M16			12 x M16			12 x M20			12 x M24		
Thread length (mm)	I	25			30			35			40		
Fit length (mm)	J	6			8			8			10		
Flange width (mm)	K	17			20			30			38		
Distance (mm)	L	48			83			108			136		
Distance (mm)	M	95			130			165			225		
Actuation path (mm)	N	4			4			7,5			10		
Bolt circle diameter ST (mm)	O	220			270			376			532		
Outer diameter hubs (mm)	P	170			218			295			418		
Bore for fastening screw (mm)	Q	max. 110			max. Ø 140			max. Ø 200			max. Ø 290		
Moment of inertia approx. at D max. (10 ⁻³ kgm ²)		370			780			4600			24600		
Speed max. (1/min.)		4200			3800			2500			2000		
Admissible max. radial force adapter flange (KN)		40			60			100			200		
Approx. weight at D max. (kg)		40			63			179			463		



MODEL ST1

Mount example with chain wheel

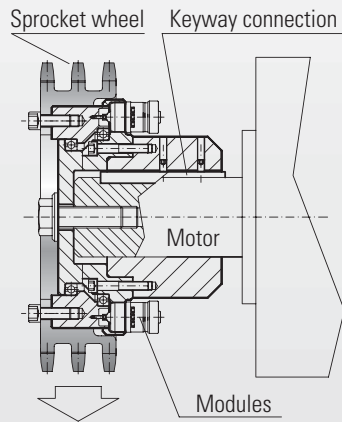

Ordering example

ST1 / 025 / 120 / 12 / 4-15 / 25 / xx

Model
 Series
 Bore \varnothing D H7
 Disengagement torque (KNm)
 Adjustment range (KNm)
 Bore for fastening screw (\varnothing Q)
 e.g. stainless steel

Design for reinforced bearing

Ordering specifications with reinforced bearing

ST1 / 025 / 120 / 12 / 4-15 / 25 / V

Standard

Non standard with strengthened bearings

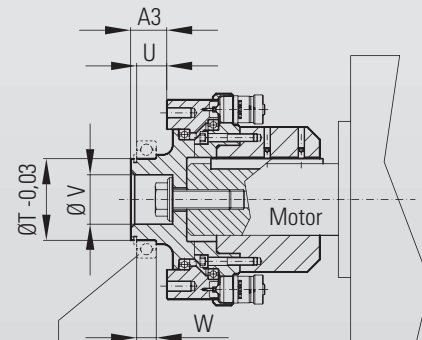
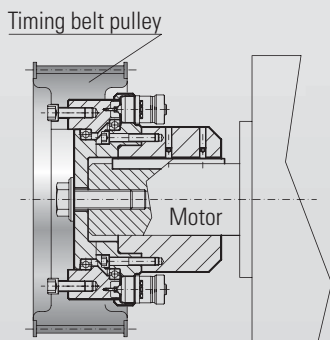

Model
 Series
 Bore \varnothing D H7
 Disengagement torque (KNm)
 Adjustment range (KNm)
 Bore for fastening screw (\varnothing Q)
 with reinforced bearing

Series		10	25	60	160
Distance (mm)	A3	48	58	72	85
\varnothing Bearing seat h7 (mm)	T	80	100	120	160
Distance (mm)	U	40	50	60	70
Diameter (mm)	V	50	64	70	105
Bearing width (mm)	W	22	24	28	38
Admissible max. radial force with reinforced bearing (KN)		120	170	350	700

Admissible max. radial force

Design for mounting on line shafts

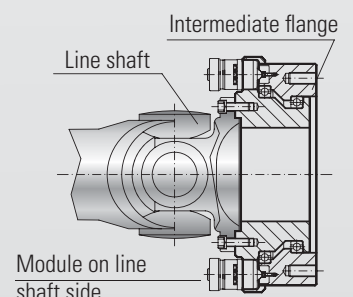
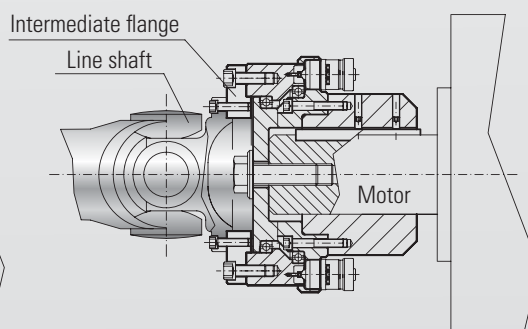
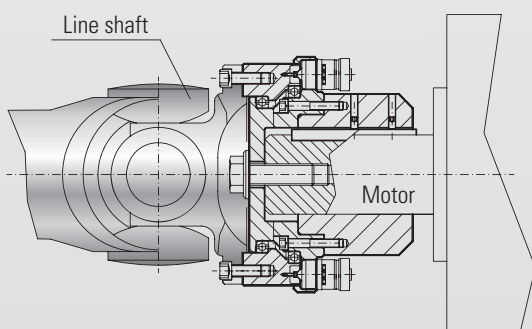

Bolt circle diameter and centering are adjusted to the line shafts.

Flange mounting possible on both sides.

Mounting with intermediate flange.



Designs for direct drives

in combination with an elastic jaw coupling

Model **ST2**



Torque 1,000 – 160,000 Nm

Features

- Vibration dampening
- Compensates for axial, lateral and angular misalignments
- Puncture-proof
- Press-fit design

in combination with a spring disc coupling

Model **ST3**

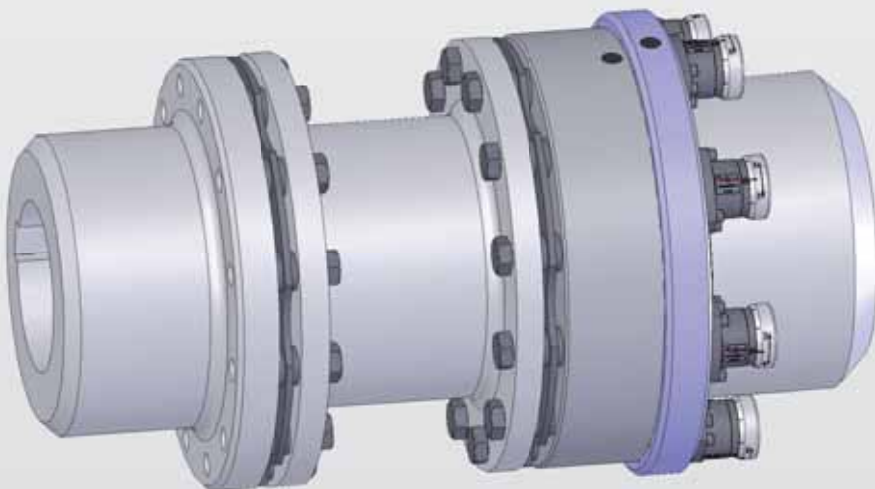

Torque 1,000 – 160,000 Nm

Features

- Torsionally rigid torque transmission
- Compensates for axial, lateral and angular misalignments
- Low restoring forces
- Wear and maintenance free



MODEL ST1/ST2/ST3

TORQUE LIMITERS

Mounting instructions

Torque adjustment

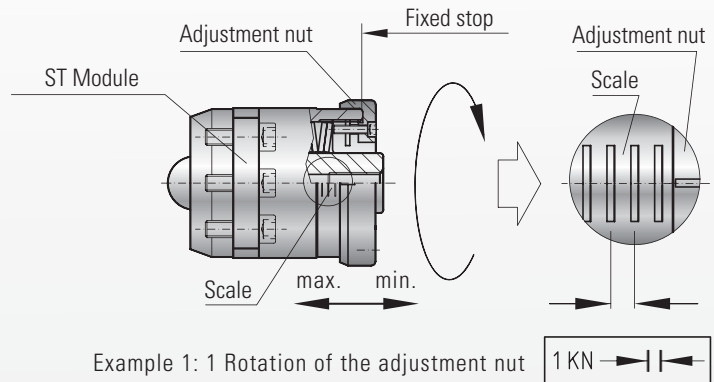
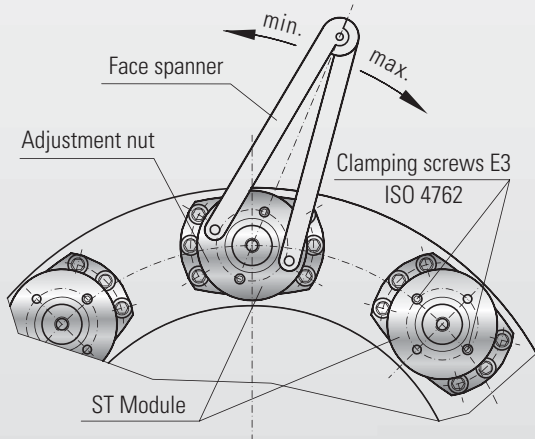

Example 1: 1 Rotation of the adjustment nut

After loosening the tightening screws (E3) the adjustment nut can be altered.

The adjusting is limited by a fixed stop at max. The upper value at min. is clearly marked on the scale. After setting the torque limiter all torque limiting parts are fixed by tightening the clamping screws (E3).

Caution: All modules of a torque limiter system must be set to the same tangential force.

Re-engagement of the individual modules

with soft hammer

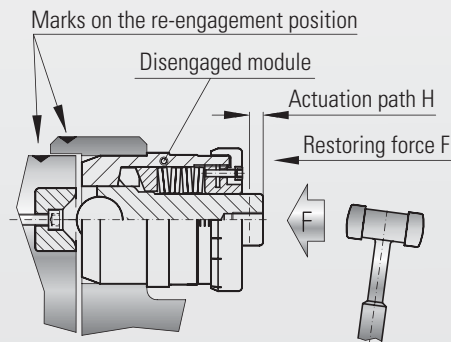

with assembly lever

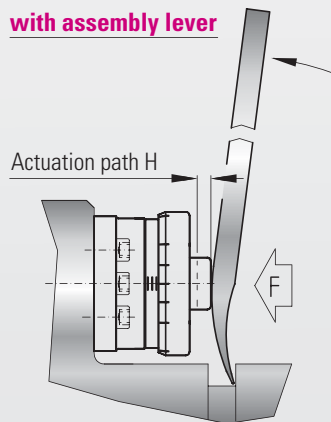

with R+W device

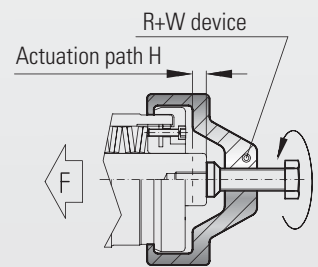

After the overload has been removed the drive and the driven side are moved to the matching marked position. Only in this position it is possible to re-engage the modules.

Applying an axial force on the plunger on the matching marked position re-engages the modules. Afterwards the torque limiter is ready for operation.

Disengagement of the individual modules

Prior to final commissioning of a machine or a plant the individual modules can be disengaged in assembled condition. The set disengagement torque can be changed more easily because of lower restoring forces due to missing spring tension. Special devices for this task can be provided by R+W.

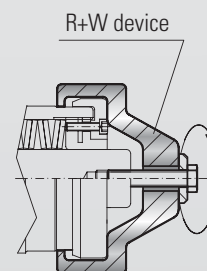



MODEL ST

MODULE

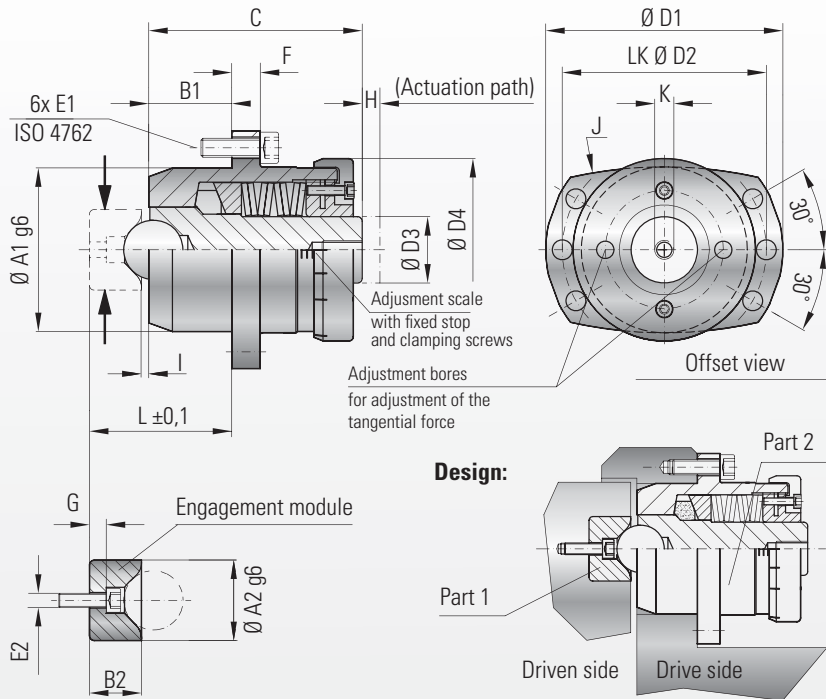

Material:

High strength hardened steel (oxidized surface)

Design:

Double assembly for mount for installation of prefabricated coupling parts

Part 1: Engagement part

Part 2: Module with spring loaded engagement plunger and integrated backing device.

The spring-tension is stepless adjustable. The adjusted force is indicated on the outboard scale.

Temperature range:

-30° C to +120° C

Service life:

Couplings are maintenance free and have extreme service life as long as the performance limits are not exceeded.

Fit tolerance:

Mounting of the modules required H7 bores.

Re-Engagement:

At synchronized angularity of the drive and driven side, the plunger can be moved into the locked position by applying an axial force.

Model ST		Series		
		15	30	70
Tangential force (KN) (ranges) Adjustment range available from – to	1	1-4	5-10	8-20
	2	2-8	10-20	15-40
	3	6-20	20-35	30-70
Centering diameter modules g6 (mm)	A1	40	70	90
Centering diameter engagement segment g6 (mm)	A2	24	34	44
Centering length modules (mm)	B1	20	35	45
Centering engagement segment (mm)	B2	14	22	30
Overall length (mm)	C	67	95	135
Outer diameter (mm)	D1	59	100	129
Bolt circle diameter (mm)	D2	50	86	110
Diameter control scale (mm)	D3	16	28	35
Outer diameter graduated collar (mm)	D4	44	75	92
Screw / tightening torque ISO 4762 (mm)	E1	6 x M5 x 16 / 10 Nm	6 x M8 x 25 / 40 Nm	6 x M12 x 35 / 120 Nm
Screw / tightening torque ISO 4762 (mm)	E2	M4 x 14 4,5 Nm	M6 x 20 15,5 Nm	M8 x 25 38 Nm
Flange thickness (mm)	F	7	12	16
Distance (mm)	G	5	8	10
Actuation path (mm)	H	4	7,5	10
Distance dimension (mm)	I	2	3	4
Radius (mm)	J	110	200	250
Inner thread (mm)	K	M8 x 15	M10 x 25	M16 x 30
Distance ± 0,1 (mm)	L	36	60	79
Weight (kg)		0,65	2,7	6

axial spring force ≈ tangential force/1,4



MODEL ST

Ordering specifications

ST / 30 / 12 / 2 / xx

Model	ST
Series	30
Tangential force (KN)	12
Adjustment Range 1/2/3	2
Non standard, e.g. Stainless Steel	xx

Maintenance:

The individual parts are sealed-for-life and strongly built. A scheduled service is not necessary. The modules have an extreme service life. After several disengagements the function of the modules need to be checked.

Mounting instructions ST

Mounting re-engagement Module

Caution: The measures L1 and L2 must be checked prior to mounting the torque limiting module.

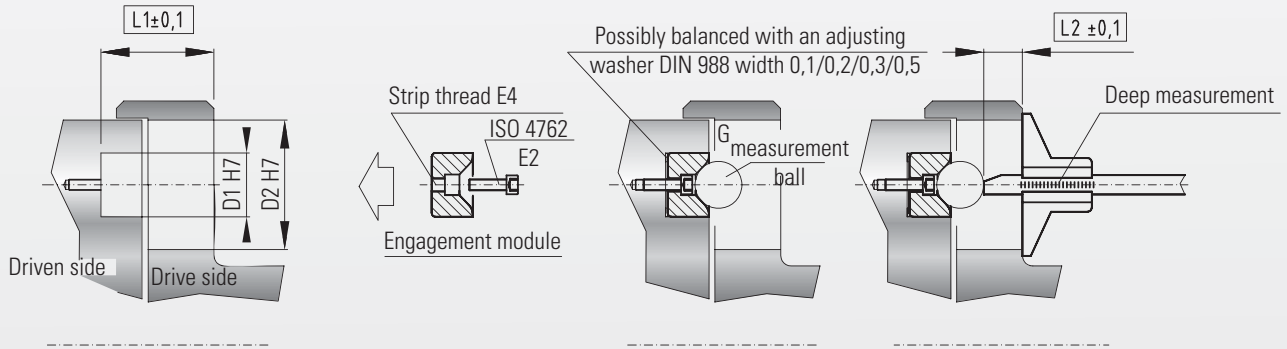

Demounting of the re-engagement module

After loosening the tightening screw E2, the re-engagement module can be dismounted with a stripping tool.

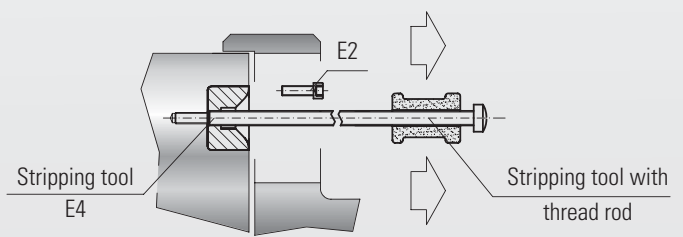

Mounting of modules

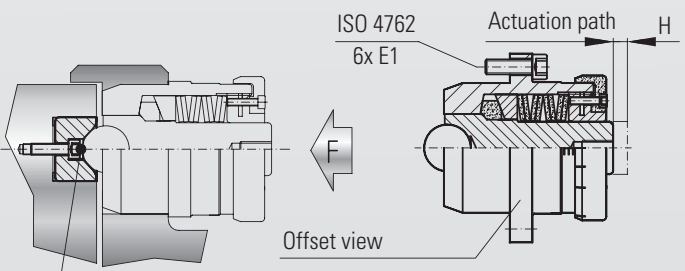

Caution: prior to mounting the module, the ball seat must be lubricated (e.g. Klüber Isoflex Topas NB 52).

Model ST	Series			
	15	30	70	
Screws	E1	6 x M5 x 16 (12.9)	6 x M8 x 25 (12.9)	6 x M12 x 35 (12.9)
Tightening torque		10 Nm	40 Nm	120 Nm
Screws	E1	1 x M4 x 12	1 x M6 x 20	1 x M8 x 25
Tightening torque		4.5 Nm	15.5 Nm	38 Nm
Screws	E3	2 x M4 x 14	4 x M4 x 16	4 x M5 x 20
Tightening torque		4 Nm	4.5 Nm	10 Nm
Strip thread	E4	M5	M8	M10
Actuation path	H	4 mm	7,5 mm	10 mm
Restoring force	F	max. 2 KN	max. 4 KN	max. 6 KN
Fitting dimensions	L1 ± 0,1	36	60	79
Check gauge	L2 ± 0,1	10	20,5	29
Measurement ball	Ø G	16	25	30



MODEL ATEX

FOR USE IN HAZARDOUS AREAS AND EXPLOSIVE ATMOSPHERE

The ATEX 95a is regulated by the new European directive. Generally the explosive atmosphere is classified in 3 different zones.

Zone 0: A place in which an explosive atmosphere consists of a mixture of air and flammable substances in the form of gas, vapor or mist and is present frequently, continuously or for extended periods.

Zone 20: Is relevant for an explosive atmosphere in the form of clouds of combustible dust in air under the same conditions as above.

Zone 1: Described as a place in which an explosive atmosphere consists of a mixture of air with flammable substances in the form of gas, vapor or mist, and is likely to occur in normal operation occasionally.

Zone 21: Is relevant for an explosive atmosphere in the form of clouds of combustible dust in air under the same conditions as above.

Zone 2: A place in which an explosive atmosphere consists of a mixture of air with flammable substances in the form of gas, vapor or mist and is not likely to occur in normal operation but, if it does occur, it will persist for only a short period.

Zone 22: Relevant for an explosive atmosphere in the form of a cloud of combustible dust in air under the same conditions as above.

For the classified zones 1/21 and 2/22 the torque limiters ST-EEx an accreditation according to ATEX 95a can be supplied.

Mounting, Design:

Detailed mounting and instruction manuals are supplied with the ST-EEx-torque limiters

Installation and Operation instructions:

Installation and operating instructions are an essential part of the ST-EEx torque limiters.

Including the following facts:

- Design of the ST EEx metal bellows couplings
- Exact tightening torques and misalignment values
- How to put in operation
- Maintenance intervals
- Trouble shooting
- Marking of the coupling
- Declaration of conformity

Identification:

All ST-EEx torque limiters are permanent labeled to display manufacturer and accreditation data.

Example Accreditation data:



Typ: ST1 25 EEx-2009
II 2 G D
EEx fr c T3 / 200°C
Ser.No.: A 200101.1
Tech.Ref.No.:2003/004RW

ACCESSORIES

Engagement- and disengagement device

Order-No.: see table

Engagement procedure

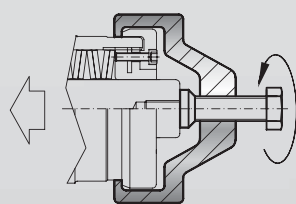

Disengagement procedure

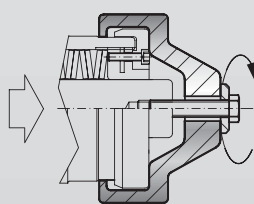

Series	Engagement- and disengagement device
15	Order-No. 15
30	Order-No. 30
70	Order-No. 70

Face spanner

Order-No.: see table

For subsequent movement of the adjusting nut

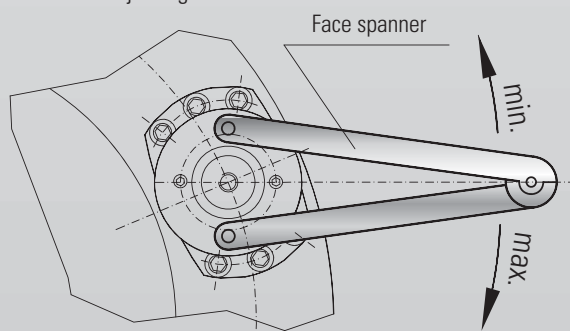

Series	Face spanner
15	Order-No. 15/4
30	Order-No. 30/6
70	Order-No. 200/8



SELECTION

According to disengagement torque

As a rule torque limiters are rated according to the required disengagement torque, which must be greater than the torque that is necessary for regular machine operation.

The disengagement torque of the torque limiters is determined as a rule in accordance with the drive specifications.

The following calculation has proven itself as a good rule of thumb:

$$T_{AR} \geq K \cdot T_{max} \text{ (Nm)}$$

K = 1,3 uniform load

K = 1,5 low load

K = 1,8 high load

or

$$T_{Drive} \geq 9550 \cdot \frac{P_{Drive}}{n} \text{ (Nm)}$$

T_{AR} = disengagement torque of the torque limiter (Nm)

K = disengagement factor

T_{max} = max. occurring torque (Nm)

T_{Drive} = nominal Torque of drive (Nm)

P_{Drive} = drive power (KW)

n = speed of drive (rpm)

According to acceleration torque (start-up at no load)

S_A = shock or load factor

$S_A = 1$ (uniform load)

$S_A = 2$ (non-uniform load)

$S_A = 3$ (high dynamic load)

$$T_{AR} \geq \alpha \cdot J_L \geq \frac{J_L}{J_A + J_L} \cdot T_{AS} \cdot S_A \text{ (Nm)}$$

T_{AR} = disengagement torque of the torque limiter (Nm)

α = angular acceleration

$$\alpha = \frac{\omega}{t} = \frac{\pi \cdot n}{t \cdot 30} \frac{1}{s^2}$$

t = acceleration time (s)

ω = angular speed in (1/s)

n = speed of drive (rpm)

J_L = moment of inertia on load side (kgm²)

J_A = moment of inertia on driving side (kgm²)

T_{AS} = peak torque of motor (Nm)

According to acceleration and load torque (start with load)

$$T_{AR} \geq \alpha \cdot J_L + T_{AN} \geq \left[\frac{J_L}{J_A + J_L} \cdot (T_{AS} - T_{AN}) + T_{AN} \right] \cdot S_A \text{ (Nm)}$$

S_A = shock or load factor

$S_A = 1$ (uniform load)

$S_A = 2$ (non-uniform load)

$S_A = 3$ (high dynamic load)

T_{AR} = disengagement torque of the torque limiter (Nm)

α = angular acceleration

$$\alpha = \frac{\omega}{t} = \frac{\pi \cdot n}{t \cdot 30} \frac{1}{s^2}$$

t = acceleration time (s)

ω = angular speed in (1/s)

n = speed of drive (rpm)

J_L = moment of inertia on load side (kgm²)

T_{AN} = load torque (Nm)

J_A = moment of inertia on driving side (kgm²)

T_{AS} = peak torque of motor (Nm)

According to the quantity of modules

$$T_{AR} = S \cdot F \cdot r$$

T_{AR} = disengagement torque of the torque limiter (Nm)

S = quantity of modules

F = tangential force (KN)

r = length of lever (m)

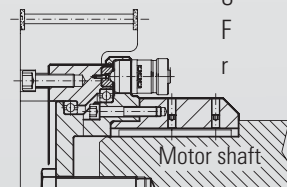
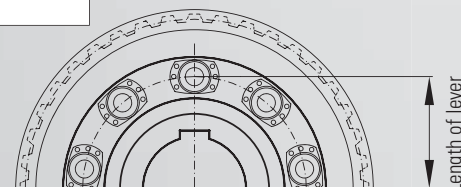

**Experience and
Know-how
for your special
requirements.**

R+W Antriebselemente GmbH
Alexander-Wiegand-Straße 8
D-63911 Klingenberg/Germany

Tel. +49-(0)9372 – 9864-0
Fax +49-(0)9372 – 9864-20

info@rw-kupplungen.de
www.rwcouplings.com

**QUALITY
MANAGEMENT**

We are certified
according to ISO 9001-2008



TGA-ZM-05-91-00
Registration No. 9605022

The information mentioned in this document is based on our present knowledge and experiences and does not exclude the manufacturer's own substantial testing of the equipment. So this is no obligatory assurance even with regard to protection rights of Third Parties. The sale of our products is subject to our General Conditions of Sale and Delivery.

THE R+W-PRODUCT RANGE



TORQUE LIMITERS Series SK

From 0.1 – 2,800 Nm, Bore diameters 3 – 100 mm
Available as a single position, multi-position, load holding, or full disengagement version
Single piece or press-fit design



BELLOWS COUPLINGS Series BK

From 2 – 10,000 Nm
Bore diameters 10 – 180 mm
Single piece or press-fit design



LINE SHAFTS Series ZA/ZAe

From 10 – 4,000 Nm
Bore diameters 10 – 100 mm
Available up to 6 mtr. length



MINIATURE BELLOWS COUPLINGS Series MK

From 0.05 – 10 Nm
Bore diameters 1 – 28 mm
Single piece or press-fit design



SERVOMAX[®] ELASTOMER COUPLINGS Series EK

From 5 – 2,000 Nm, Shaft diameters 3 – 80 mm
backlash-free, press-fit design



ECOLIGHT[®] ELASTOMER COUPLINGS Series TX 1

From 2 – 810 Nm
Shaft diameters 3 – 45 mm



LINEAR COUPLINGS Series LK

From 70 – 2,000 N
Thread M5 – M16



POLYAMID COUPLINGS MICROFLEX Series FK 1

Rated torque 1 Ncm
Bore diameters 1 – 1.5 mm