

Safety information



Stored charge

The drive contains capacitors that remain charged to a potentially lethal voltage after the AC supply has been disconnected. If the drive has been energised, the AC supply must be isolated at least ten minutes before work may continue. Refer to section 3.1 *Safety information* in the *Unidrive SP User Guide*.



If the drive has been used at high load levels for a period of time, the heatsink and heatsink mounted braking resistor can reach temperatures in excess of 70°C (158°F). Human contact with the heatsink and heatsink mounted braking resistor should be restricted.



To avoid the risk of fire when the drive is surface mounted with the braking resistor fitted, the back plate should be a non-flammable material.

Introduction

This braking resistor has been especially designed to be mounted within the heatsink of the Unidrive SP size 1. The design of the resistor is such that no thermal protection circuit is required, as the device will fail safely under fault conditions. The in-built software overload protection is set up at default to protect the braking resistor.

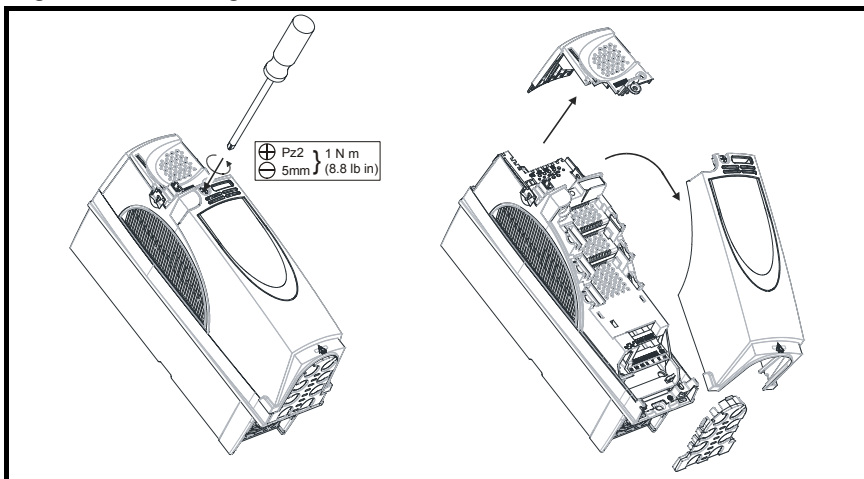
Contents of the Box (1220-2756-01)

The following items should be supplied in the box:

1x 75Ω brake resistor 1x Through-panel grommet 1x Installation sheet

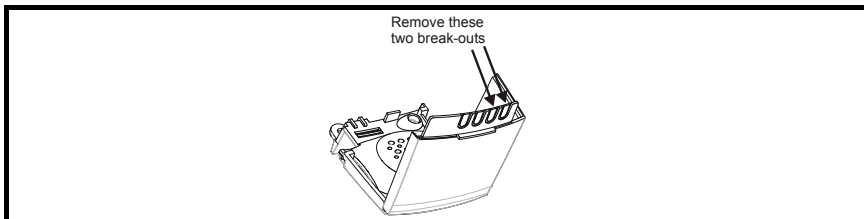
Fitting instructions

Figure 1-1 Removing the terminal covers



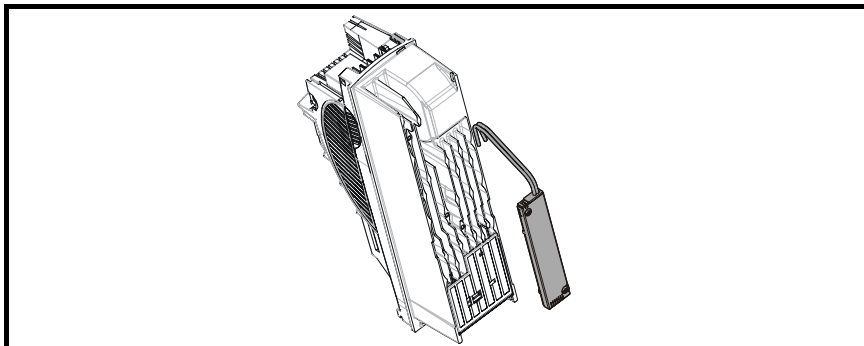
- To remove a terminal cover, undo the screw and lift the terminal cover off as shown in the diagram opposite.
- The main terminal cover must be removed first before the 48V/DC terminal cover can be removed.
- When replacing the terminal covers the screws should be tightened to a maximum torque of 1 N m (0.7 lb ft).

Figure 1-2 Remove DC terminal cover break-outs



- The two break-outs that line up with the BR and +DC terminal connections must be removed, as shown in the diagram opposite.
- Grasp the 48V/DC terminal cover break-outs with pliers and twist to remove.
- Remove any flash / sharp edges once the break-outs are removed.

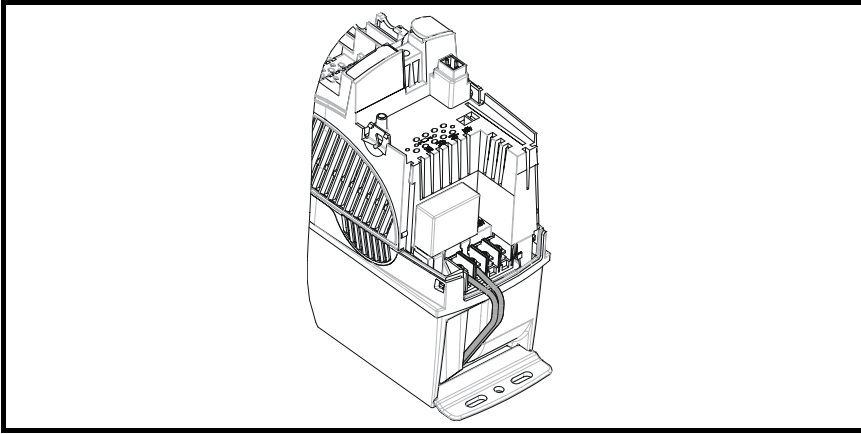
Figure 1-3 Fitting of the heatsink mounted braking resistor



- Fit the braking resistor to the heatsink as shown in the diagram opposite. The resistor is fitted with captive screws.
- The screws should be tightened to a maximum torque of 2 N m (1.5 lb ft).
- Ensure the cables are routed between the fins of the heatsink, and that the cables are not trapped between heatsink fins and the resistor.

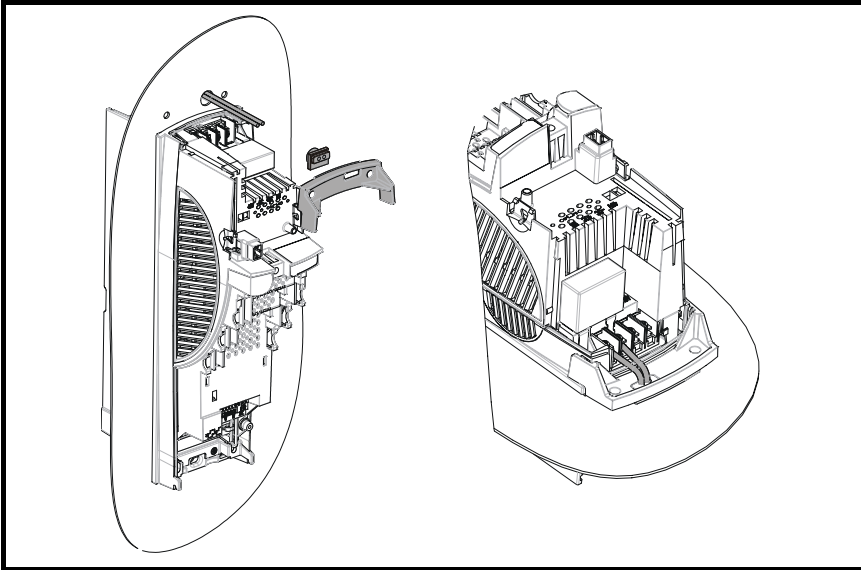


Figure 1-4 Connecting the brake resistor on a surface mounted drive



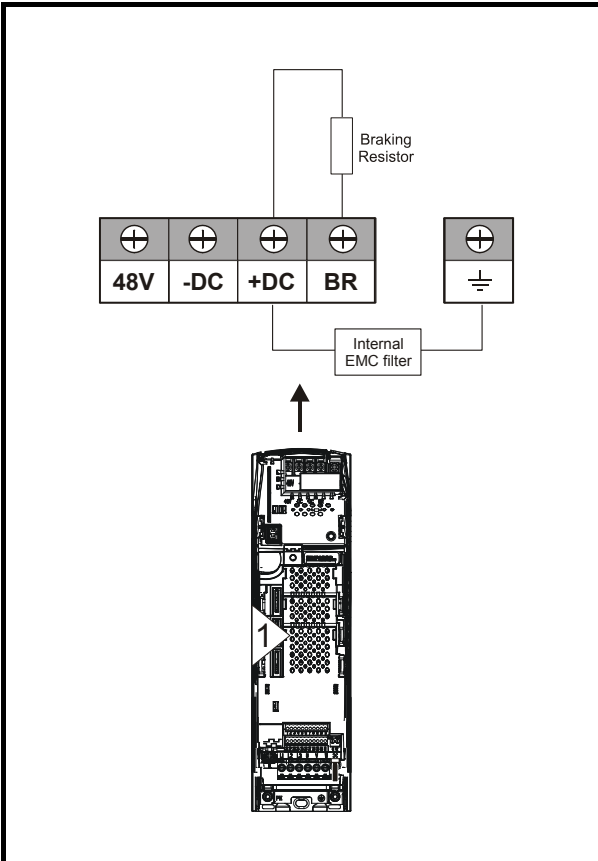
- Fit the 48V/DC terminal cover grommets supplied in the accessory box with the drive, to the cables.
- Terminate the cables with suitable crimps and connect to the BR and +DC terminals. Tighten the screw terminals to a maximum torque of 1.5 Nm (1.1 lb ft).
- Replace both terminal covers.

Figure 1-5 Connecting the brake resistor on a through-panel mounted drive



- See section 3.10 in the *Unidrive SP User Guide* for through-panel mounting cut-out details.
- Pass the cables through the hole in the panel and fit the through-panel grommet.
- Fit the through-panel mounting bracket.
- Fit the 48V/DC terminal cover grommets supplied in the accessory box with the drive, to the cables. To ensure a good seal, the grommets are a tight fit. Lubrication may be required to help fit the grommets to the cables.
- Terminate the cables with suitable crimps and connect to the BR and +DC terminals. Tighten the screw terminals to a maximum torque of 1.5 Nm (1.1 lb ft).
- Replace both terminal covers.

Figure 1-6 Unidrive SP size 1 DC connections



Failure to observe the following information may damage the resistor.

Parameter Settings

The Unidrive SP software contains an overload protection function for a braking resistor. On Unidrive SP size 1 this function is enabled at default to protect the heatsink mounted resistor. Below are the parameter settings.

Parameter		200V Drive	400V Drive
Full power braking time	Pr 10.30	0.09	0.02
Full power braking period	Pr 10.31	2.0	

For more information on the braking resistor software overload protection, see the *Unidrive SP Advanced User Guide*.

If the resistor is to be used at more than half of its average power rating then the drive's cooling fan must be set to full speed by setting Pr 6.45 to On (1).

Resistor Specification

Parameter	Value
DC resistance at 25°C	75Ω
Peak instantaneous power over 1ms at nominal resistance	8kW
Average power over 60s	50W *
Ingress Protection (IP) rating	IP54
Maximum altitude	2000m

* To keep the temperature of the resistor below 70°C (158°F) in a 30°C (86°F) ambient, the average power rating is 50W. The above parameter settings ensure this is the case.

Approvals

The resistor is UL recognised under UL file number E234469.

